



(19) **United States**
(12) **Patent Application Publication**
Edwards et al.

(10) **Pub. No.: US 2015/0045786 A1**
(43) **Pub. Date: Feb. 12, 2015**

(54) **SYSTEM FOR TREATING GASTRIC REFLUX BY TIGHTENING A LOWER ESOPHAGEAL SPHINCTER**

Publication Classification

(71) Applicant: **Mederi Therapeutics, Inc.**, Norwalk, CT (US)

(51) **Int. Cl.**
A61B 18/12 (2006.01)
A61N 1/06 (2006.01)
A61B 18/14 (2006.01)

(72) Inventors: **Stuart D. Edwards**, Portola Valley, CA (US); **John W. Gaiser**, Mountain View, CA (US); **David S. Utley**, San Carlos, CA (US)

(52) **U.S. Cl.**
CPC *A61B 18/1233* (2013.01); *A61B 18/1492* (2013.01); *A61N 1/06* (2013.01); *A61B 2017/00039* (2013.01)
USPC **606/34**

(73) Assignee: **Mederi Therapeutics, Inc.**, Norwalk, CT (US)

(57) **ABSTRACT**

(21) Appl. No.: **14/511,497**

A method of treating a sphincter provides a sphincter electropotential mapping device with at least one of a mapping electrode or a treatment electrode. The sphincter electropotential mapping device is introduced into at least a portion of the sphincter, the lower esophageal sphincter, stomach, the cardia or the fundus. Bioelectric activity causing a relaxation of the sphincter is detected and energy is delivered from either the mapping electrode or the treatment electrode to treat the bioelectric activity. A method of treating a sphincter provides a sphincter electropotential mapping device with at least one of a mapping electrode or a treatment electrode. The sphincter electropotential mapping device is introduced into at least a portion of the sphincter, the lower esophageal sphincter, stomach, the cardia or the fundus. Bioelectric activity causing a relaxation of the sphincter is detected and energy is delivered from either the mapping electrode or the treatment electrode to treat the bioelectric activity.

(22) Filed: **Oct. 10, 2014**

Related U.S. Application Data

(60) Continuation of application No. 12/584,509, filed on Sep. 8, 2009, now Pat. No. 8,870,862, which is a division of application No. 11/230,801, filed on Sep. 20, 2005, now Pat. No. 7,585,296, which is a division of application No. 10/156,505, filed on May 28, 2002, now Pat. No. 6,974,456, which is a continuation of application No. 09/410,448, filed on Oct. 1, 1999, now Pat. No. 6,405,732, which is a continuation-in-part of application No. 09/026,086, filed on Feb. 19, 1998, now Pat. No. 6,006,755.

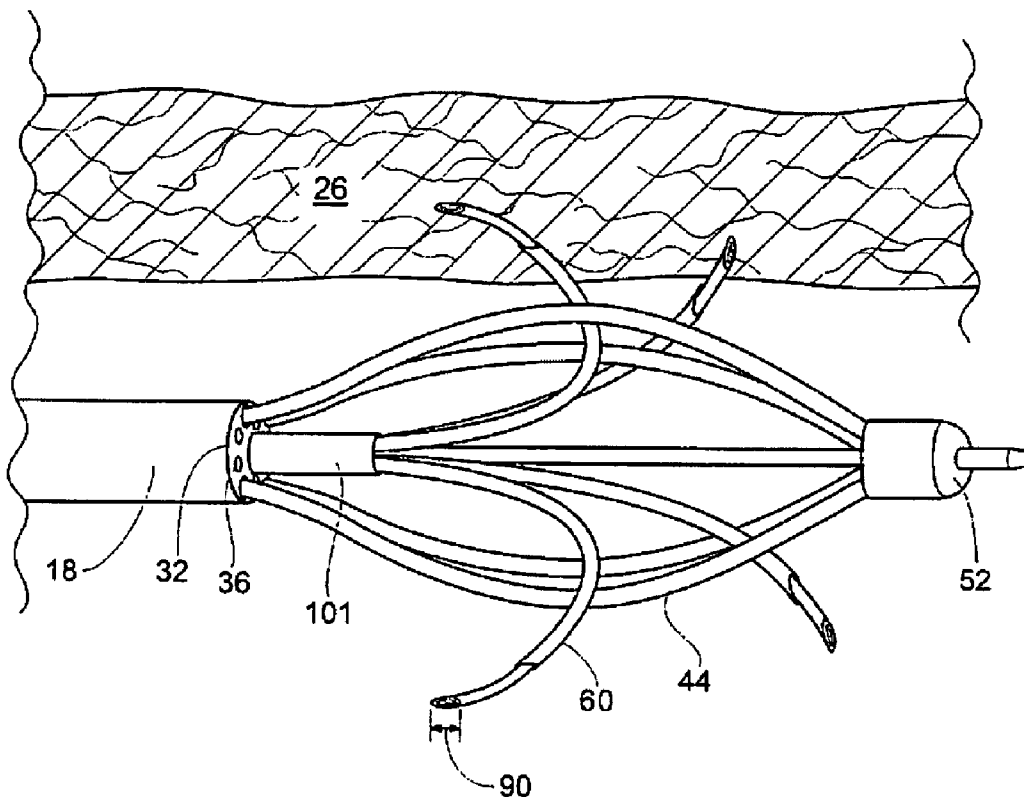

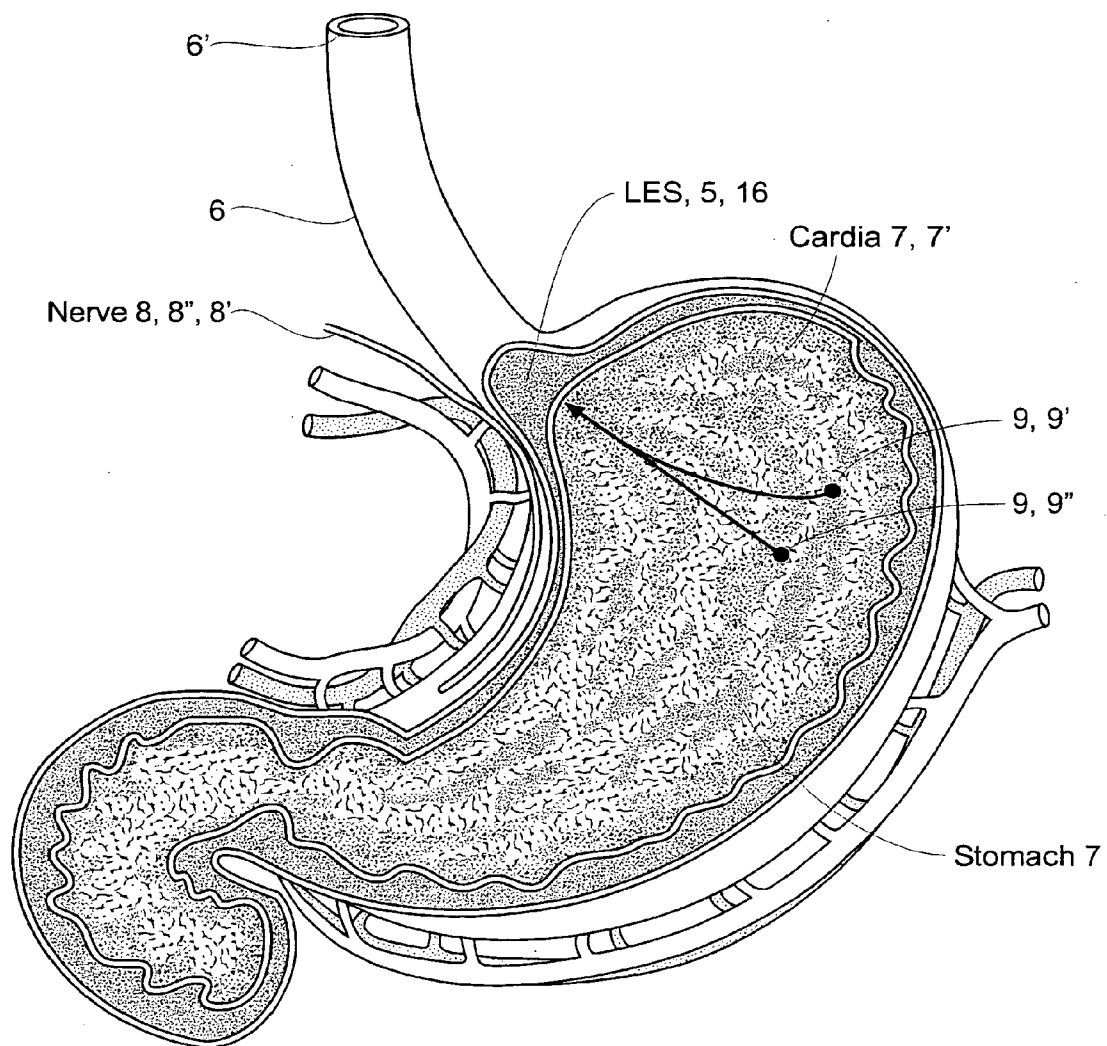

Fig. 1

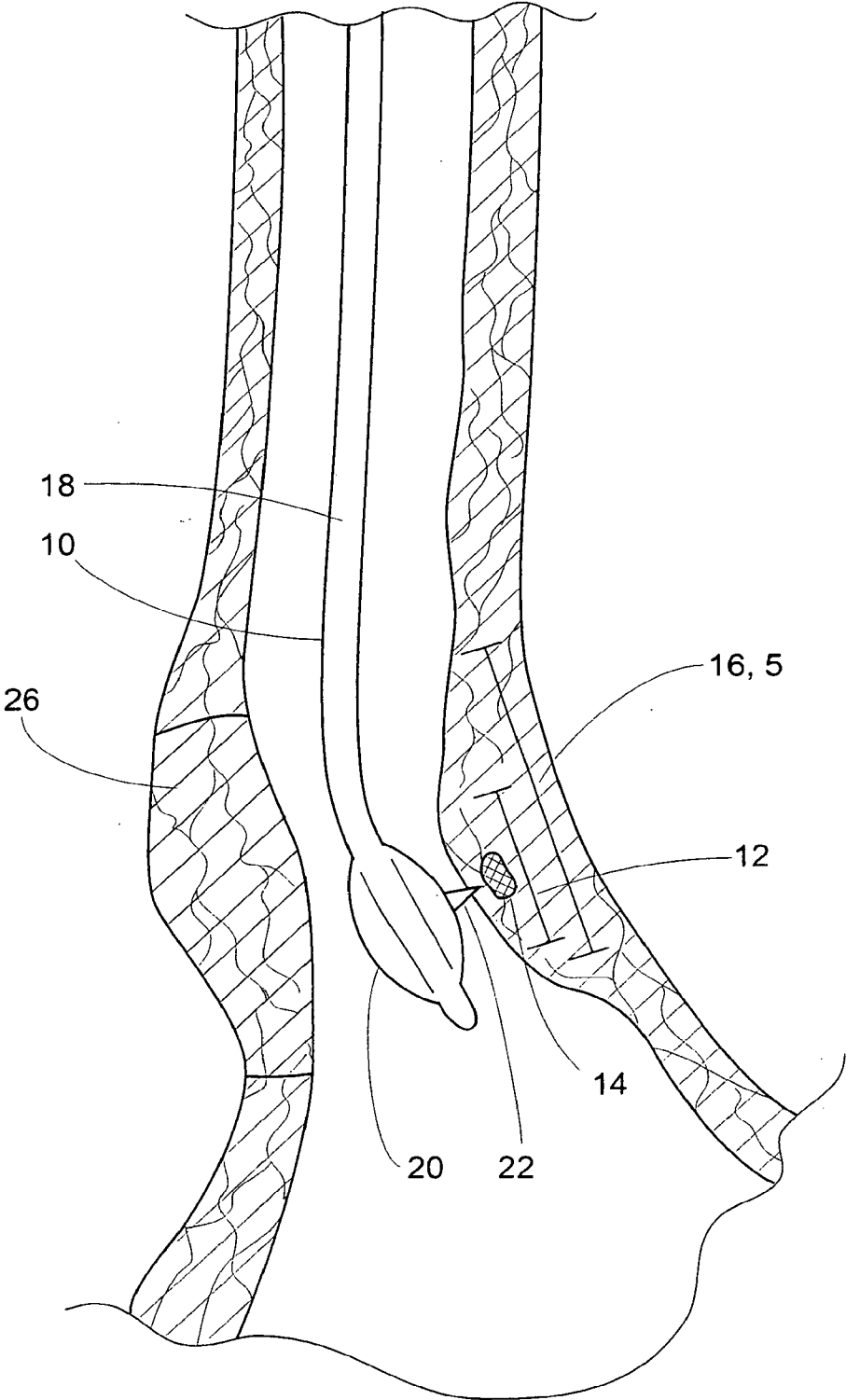
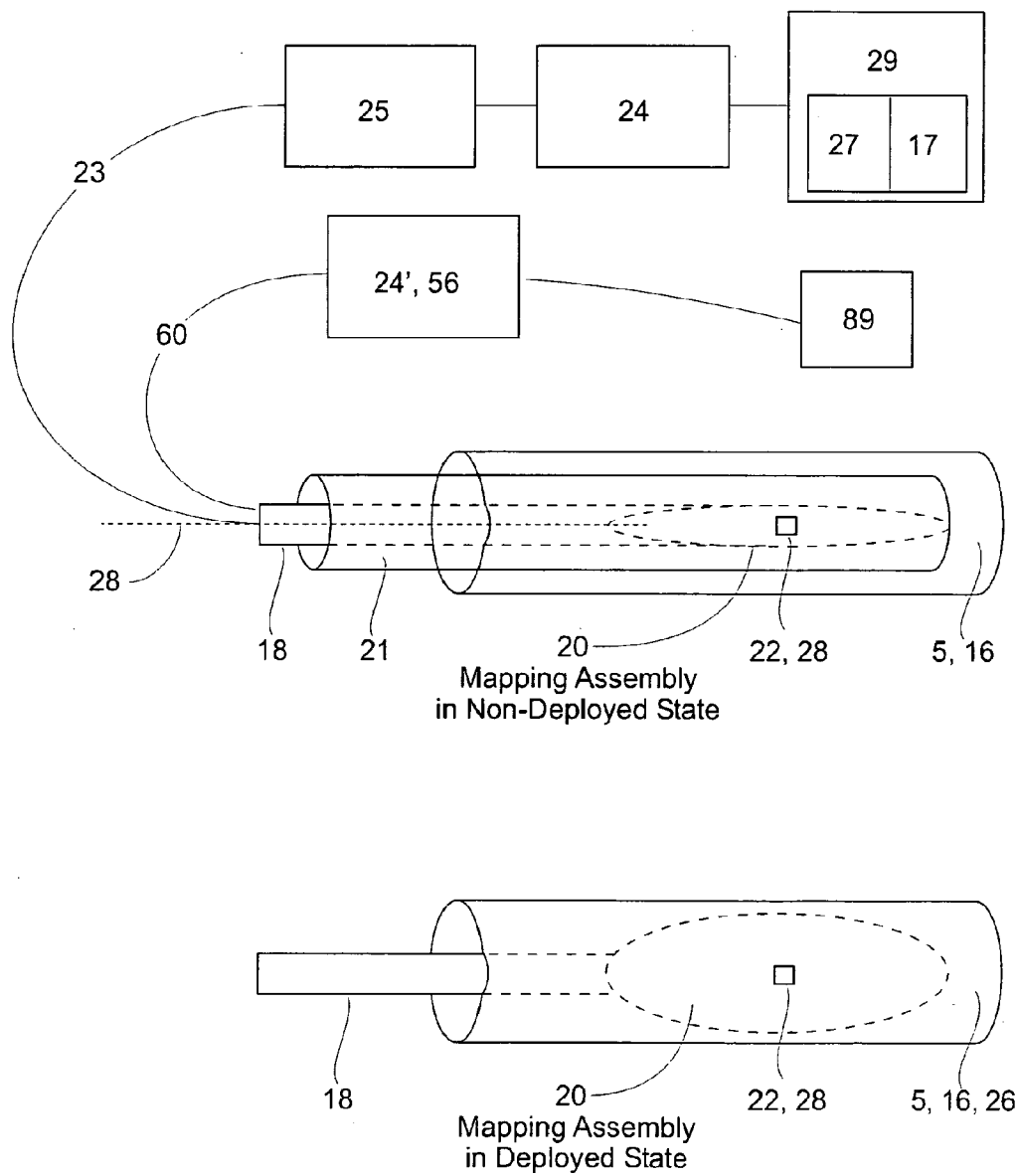

Fig. 2a

Fig. 2b



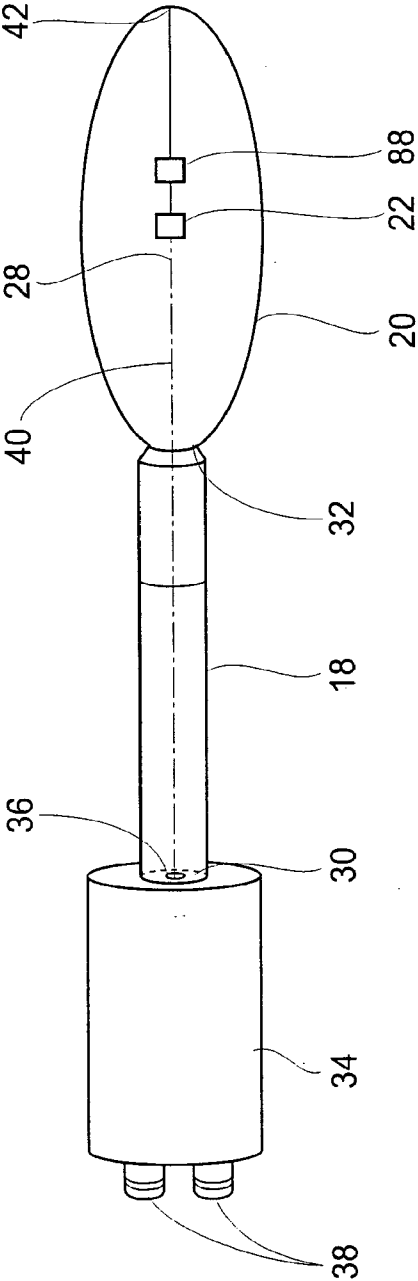

Fig. 3

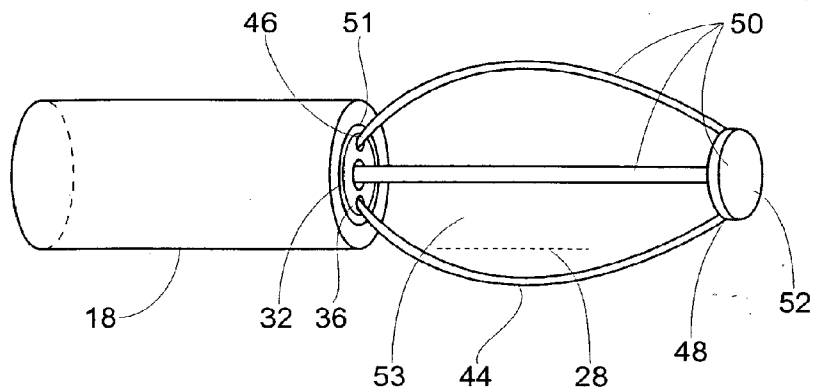

Fig. 4a

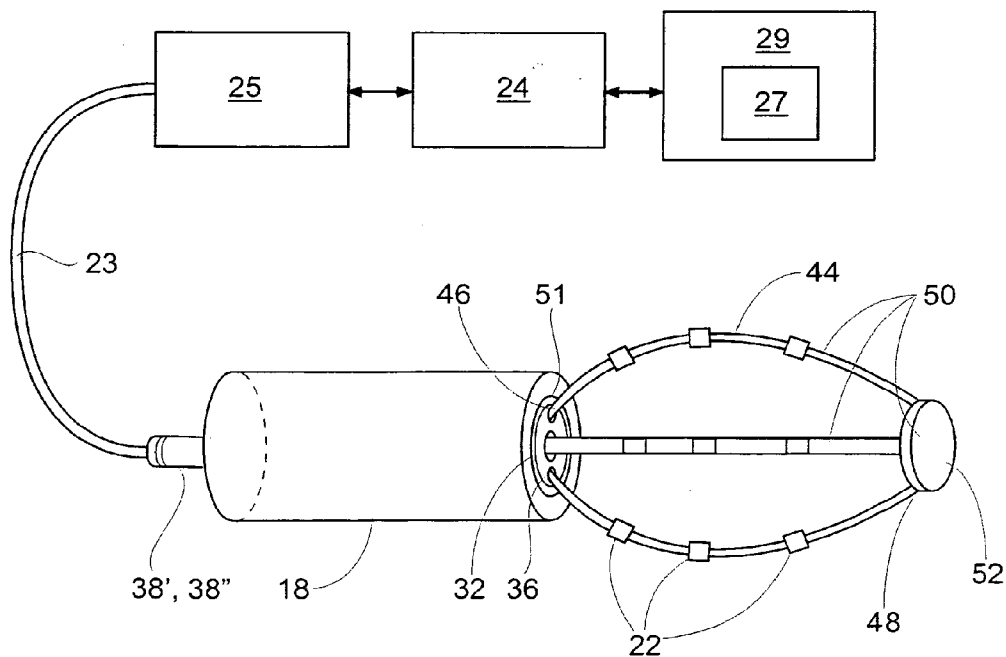

Fig. 4b

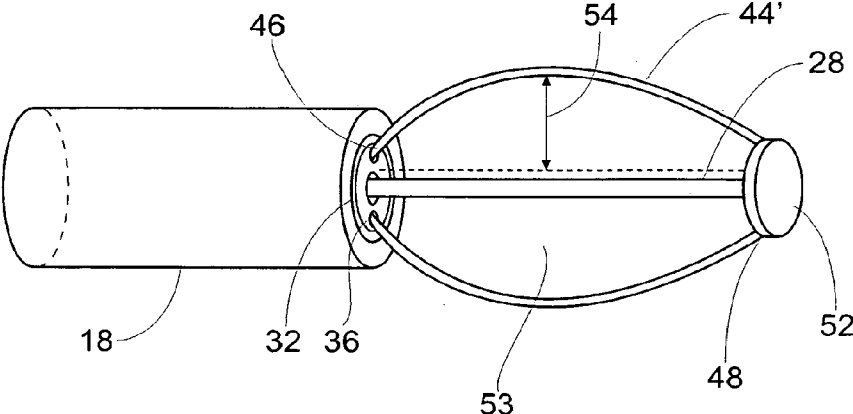

Fig. 5a

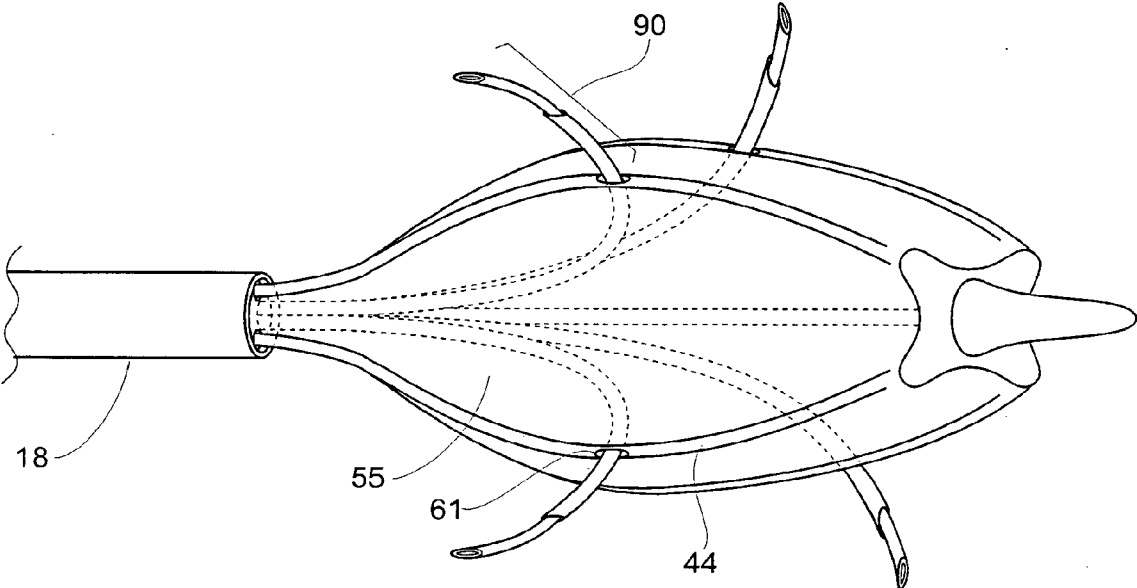

Fig. 5b

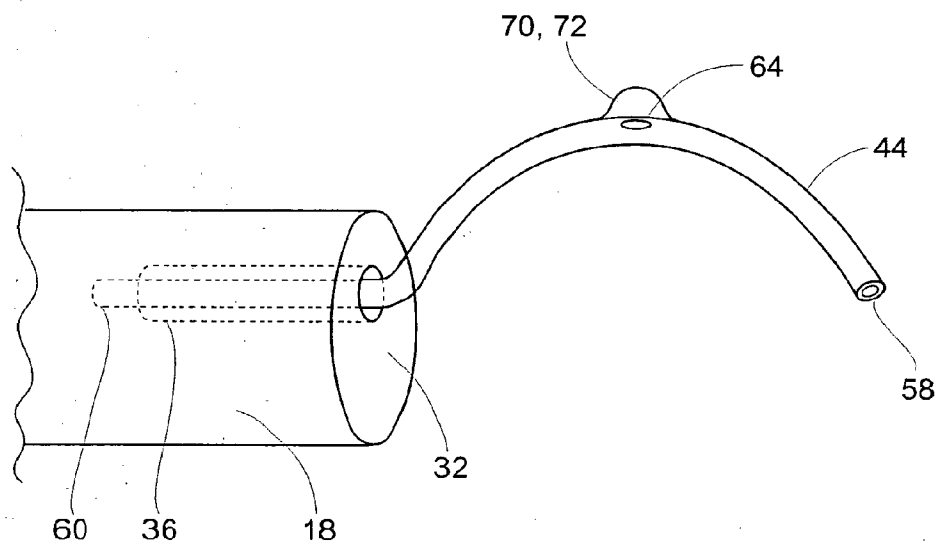

Fig. 6a

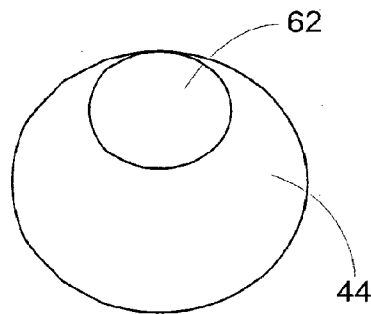

Fig. 6b

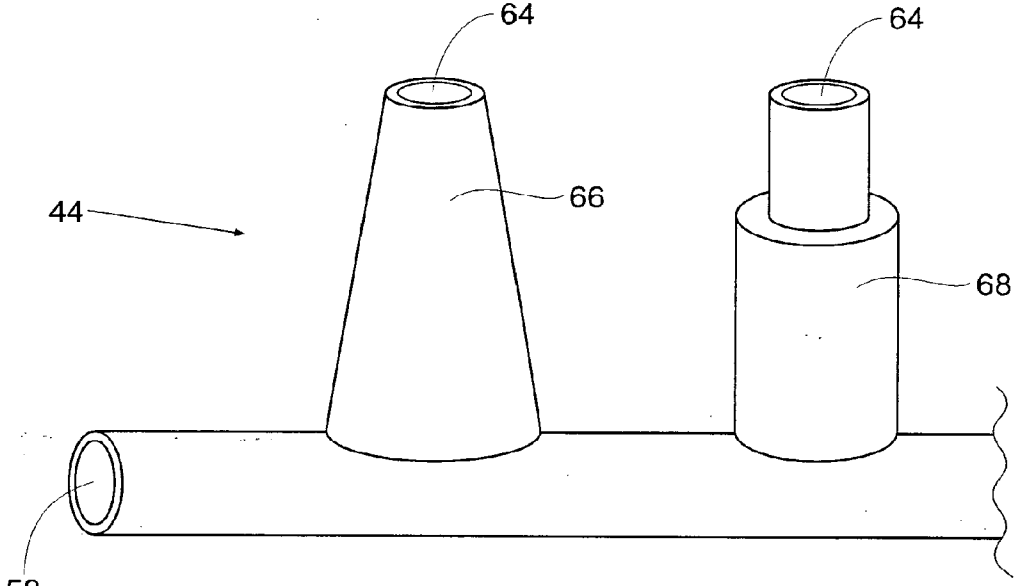

Fig. 7

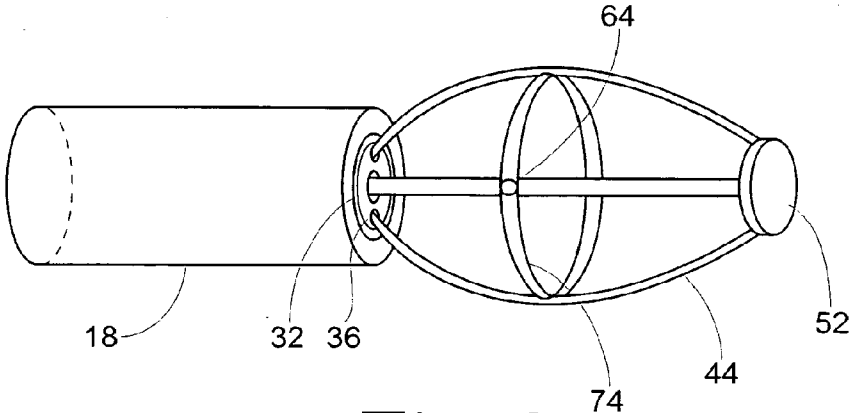

Fig. 8

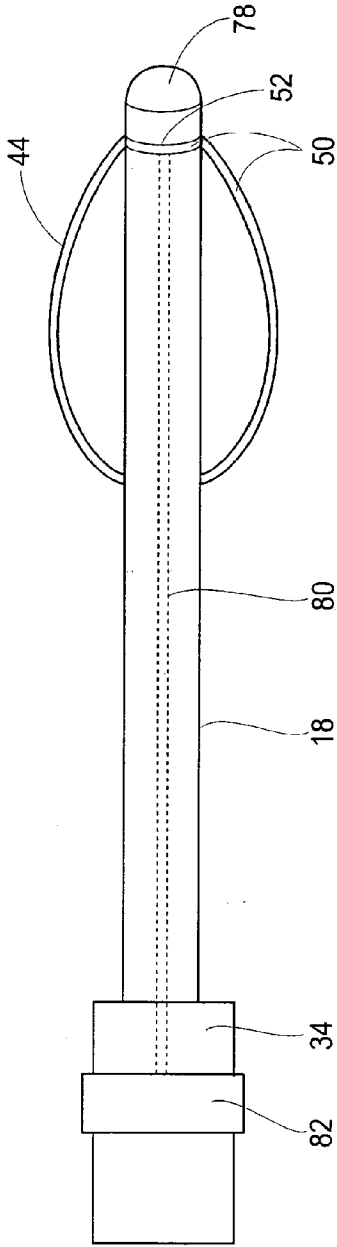

Fig. 9a

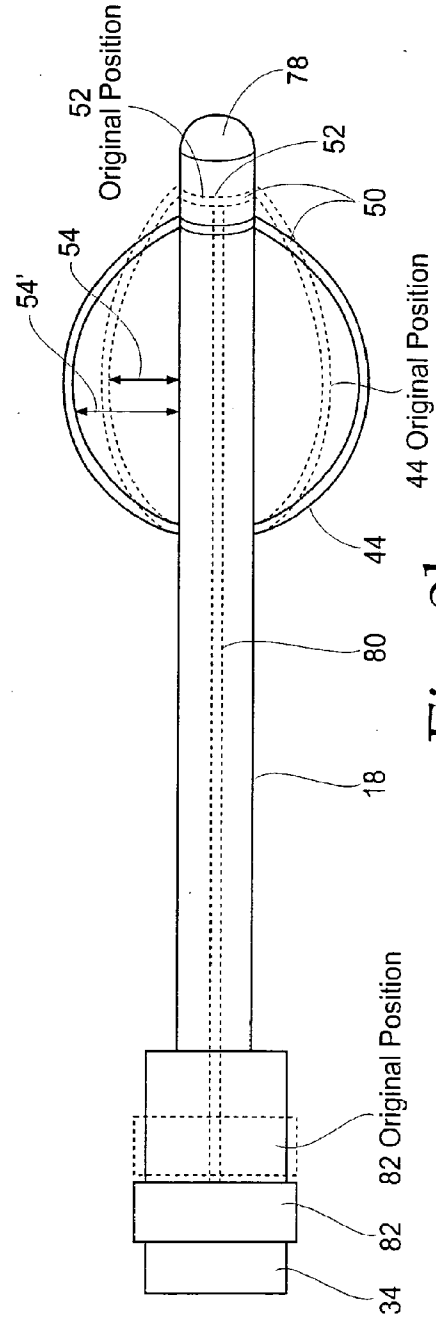

Fig. 9b

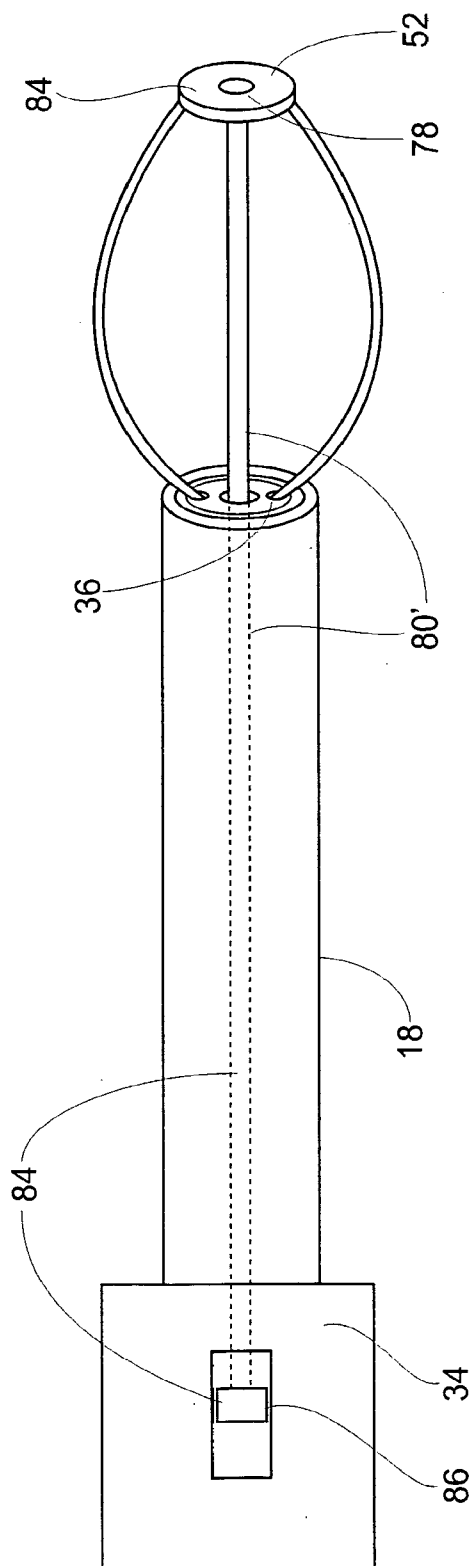

Fig. 10

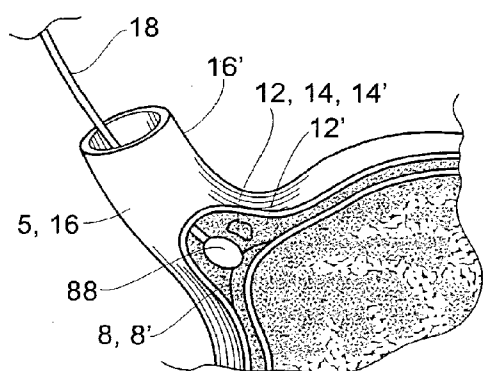
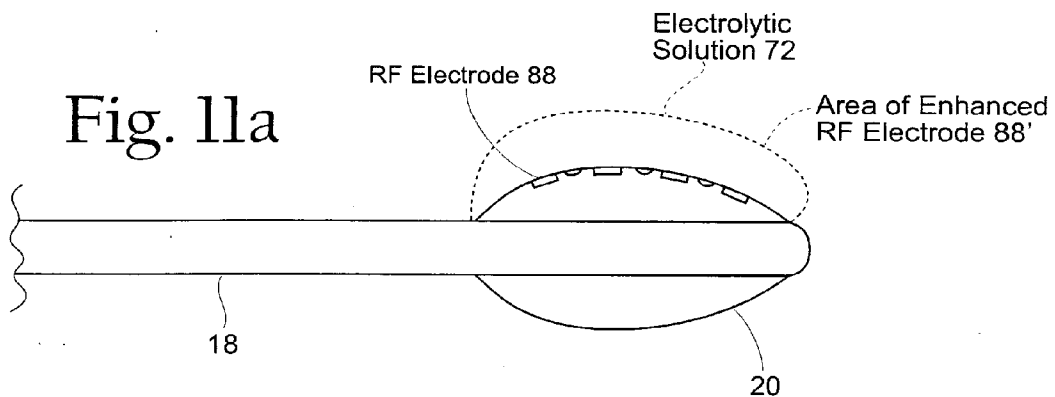
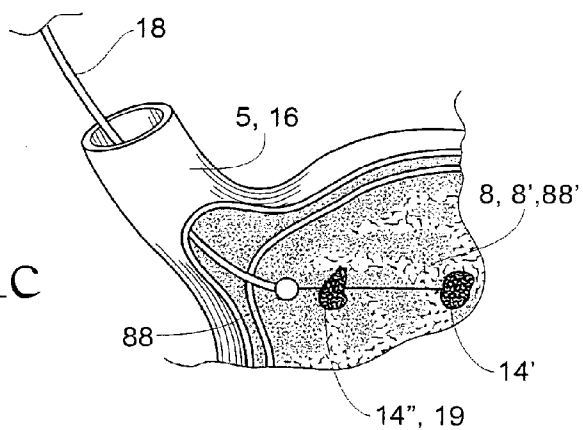

Fig. 11b

Fig. 11c



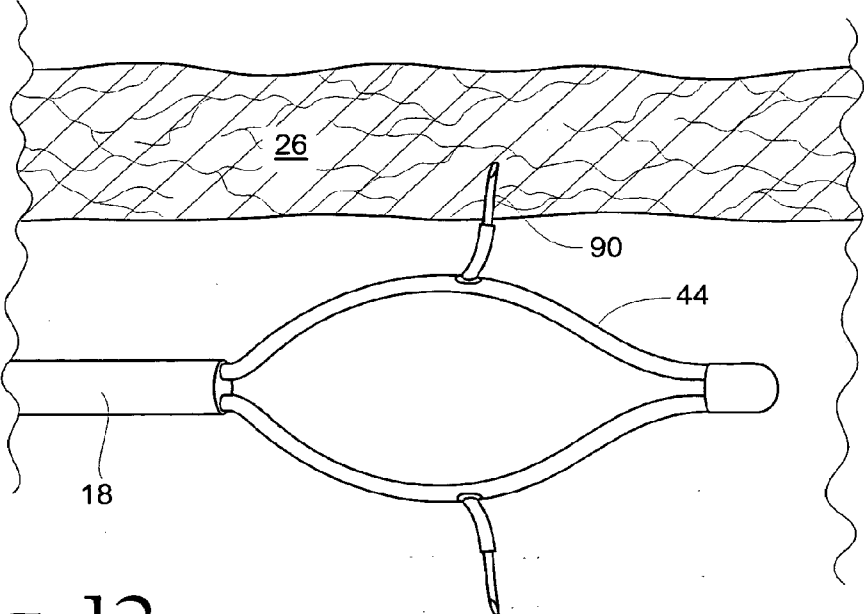
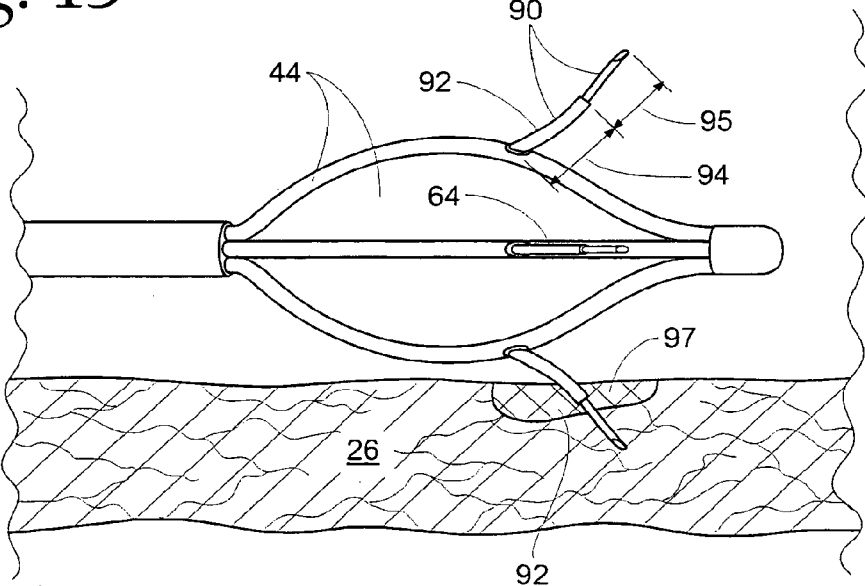

Fig. 12

Fig. 13



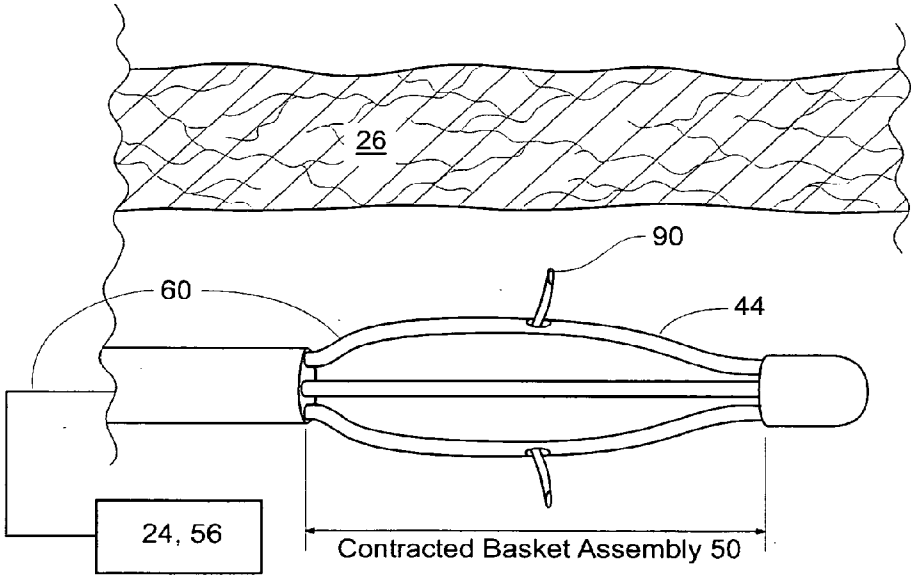

Fig. 14a

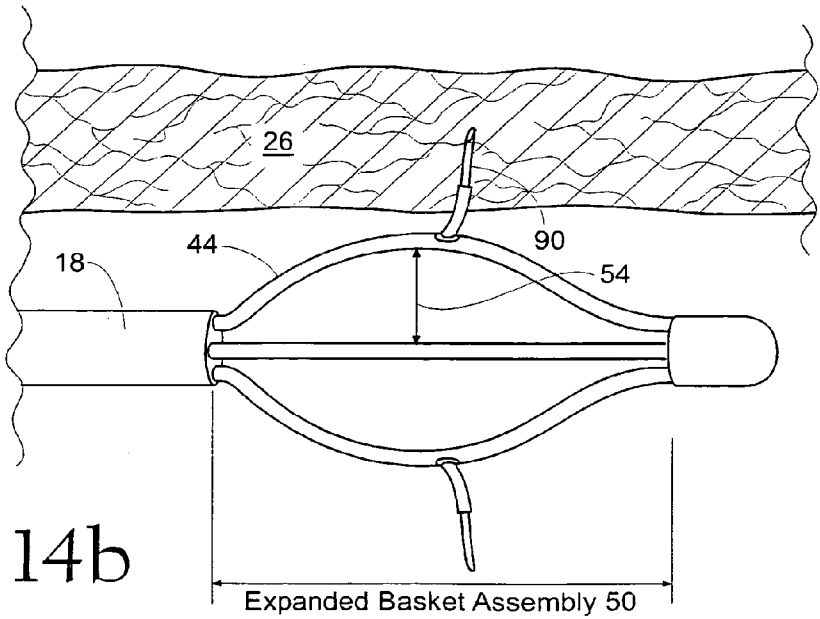

Fig. 14b

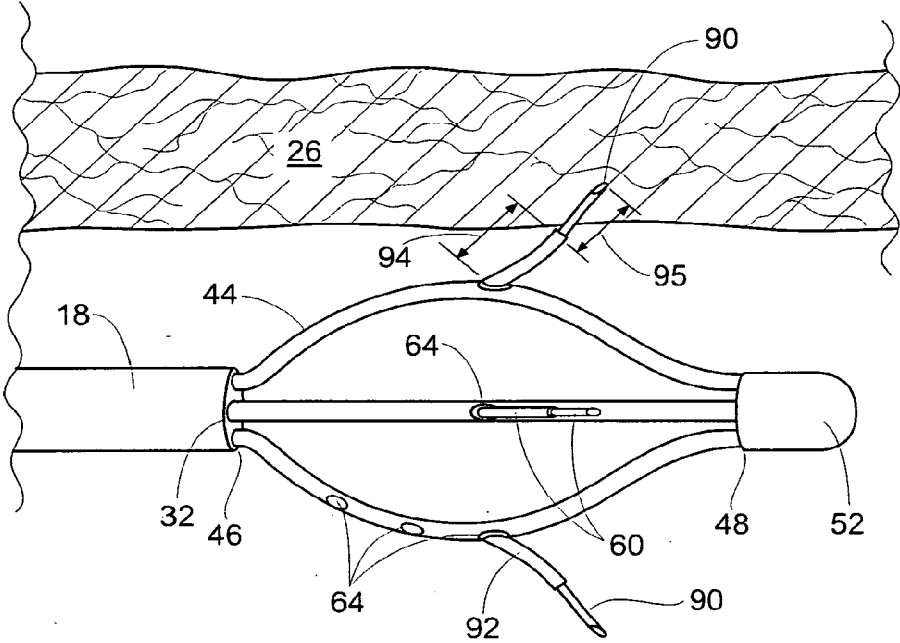

Fig. 15

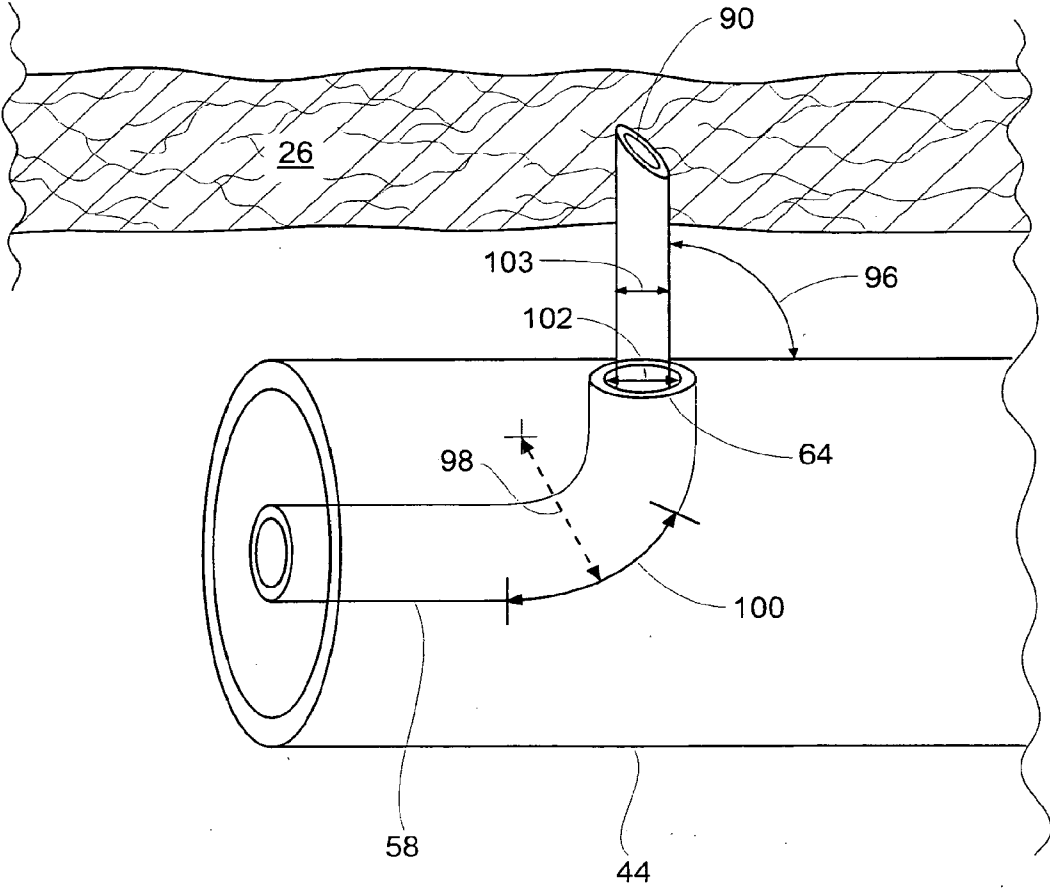

Fig. 16

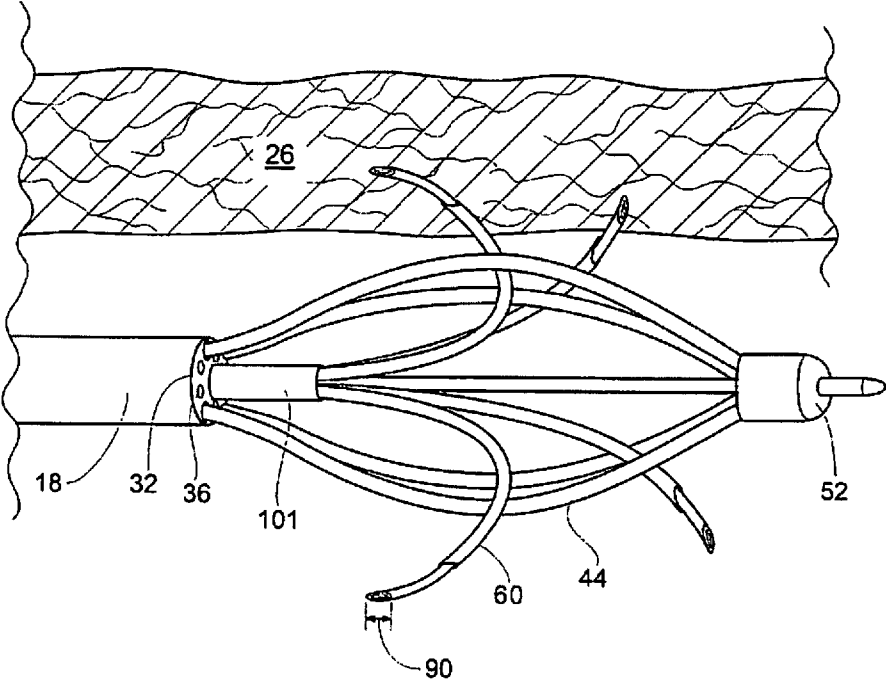

Fig. 17

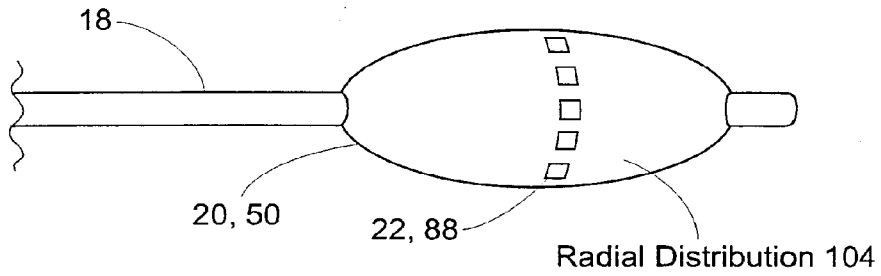

Fig. 18a

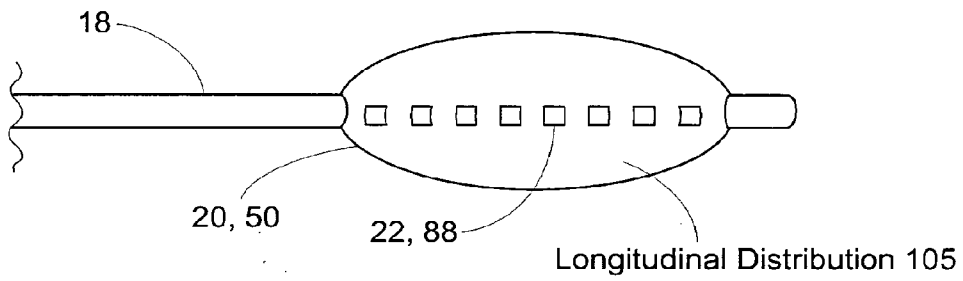

Fig. 18b

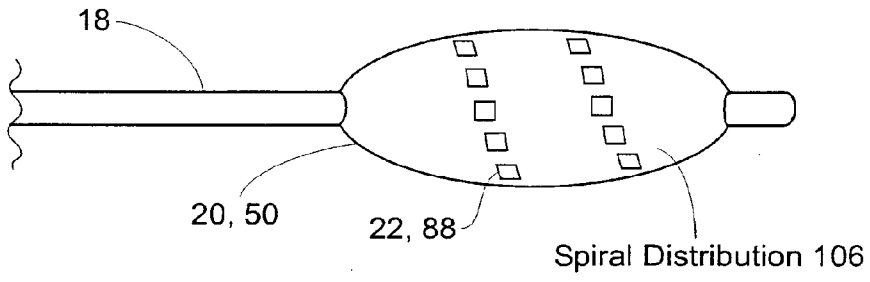

Fig. 18c

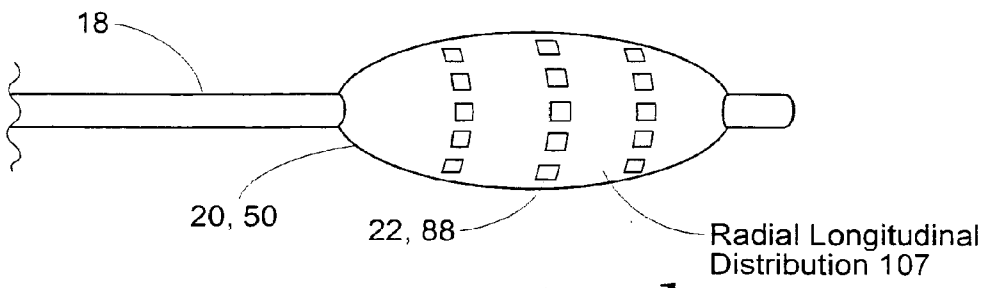

Fig. 18d

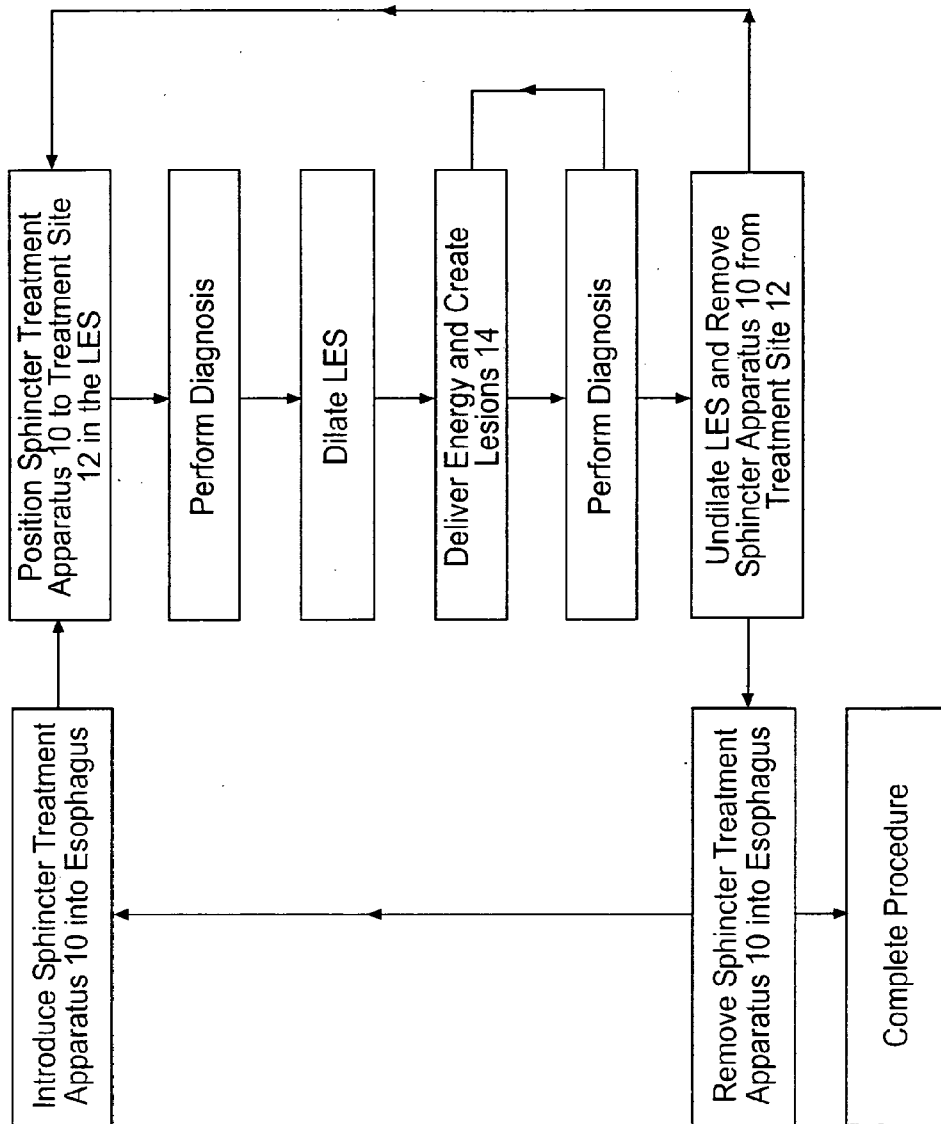

Fig. 19

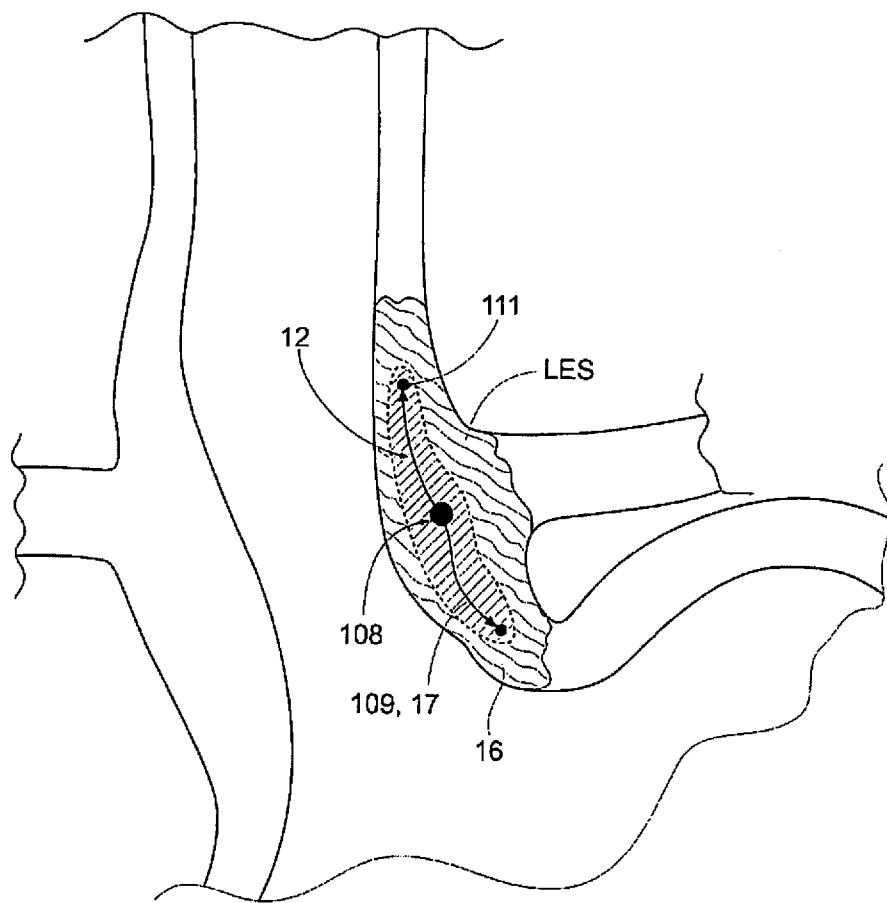

Fig. 20

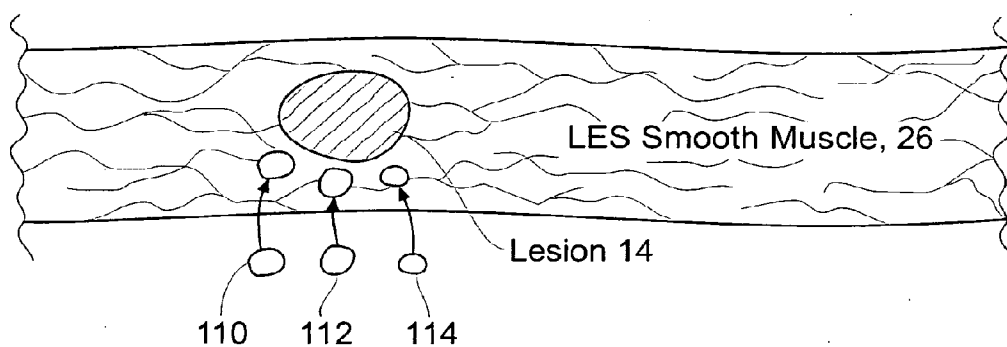

Fig. 21

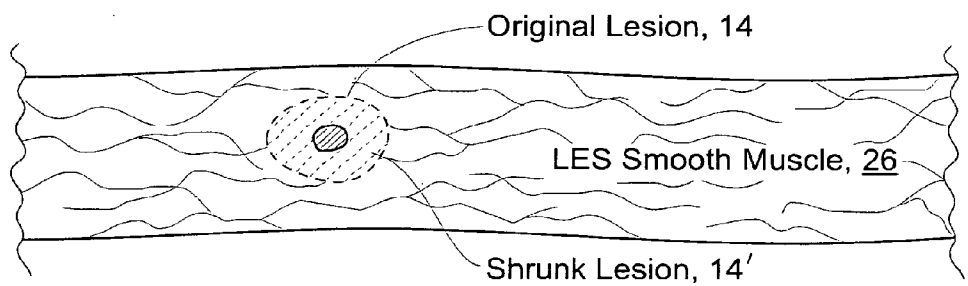

Fig. 22

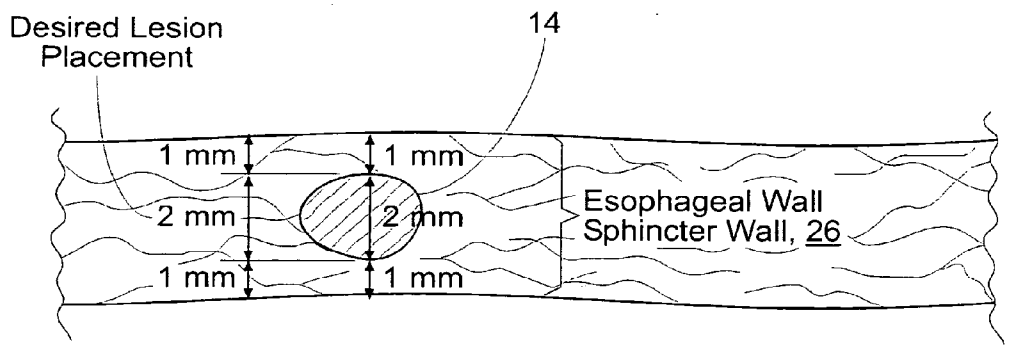

Fig. 23

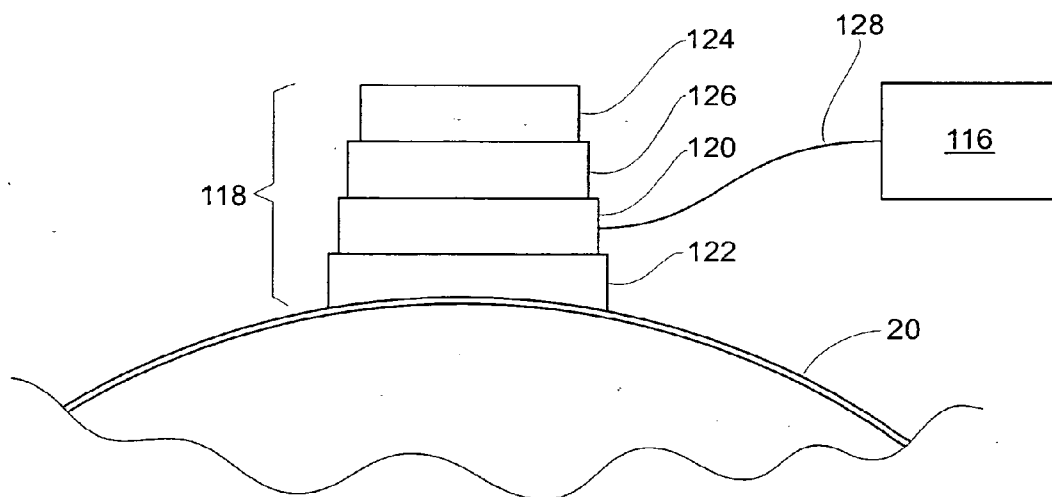

Fig. 24

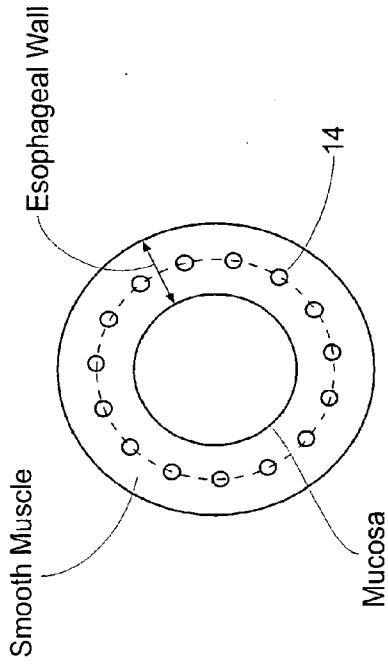

Fig. 25a

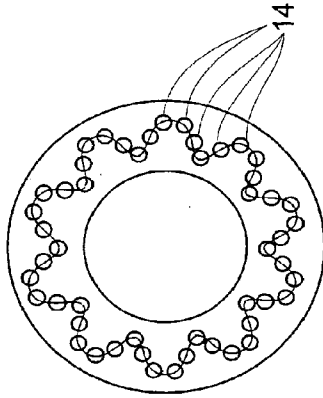

Fig. 25b

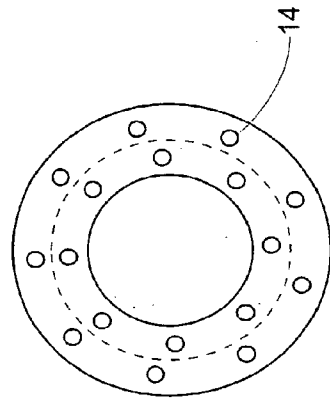

Fig. 25c

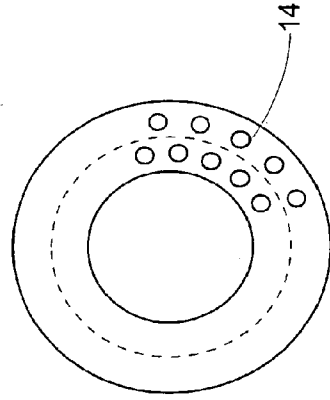

Fig. 25d

Fig. 25e

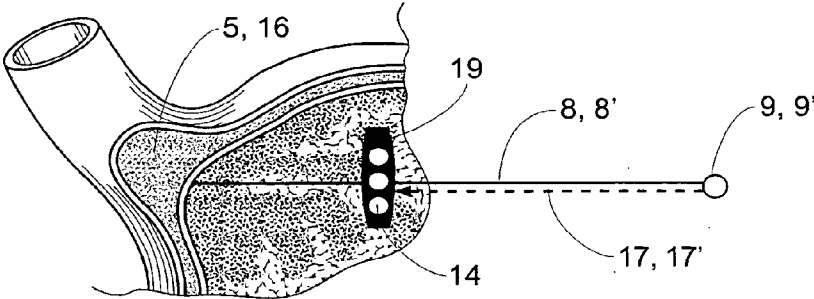

Fig. 25f

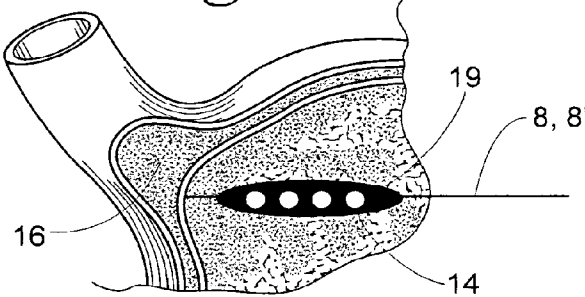
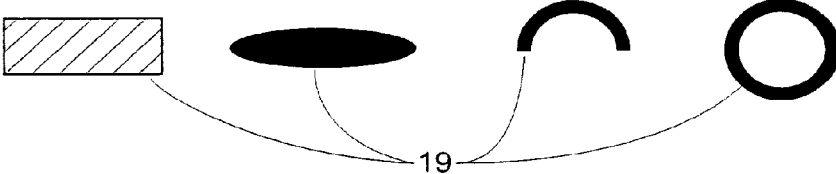

Fig. 25g

Shapes of Areas of Electrical Blockage



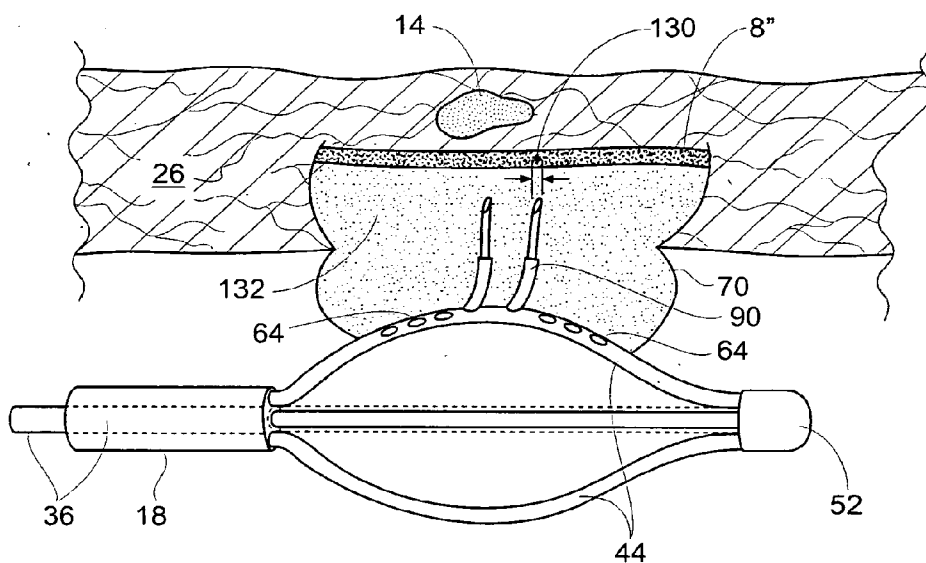
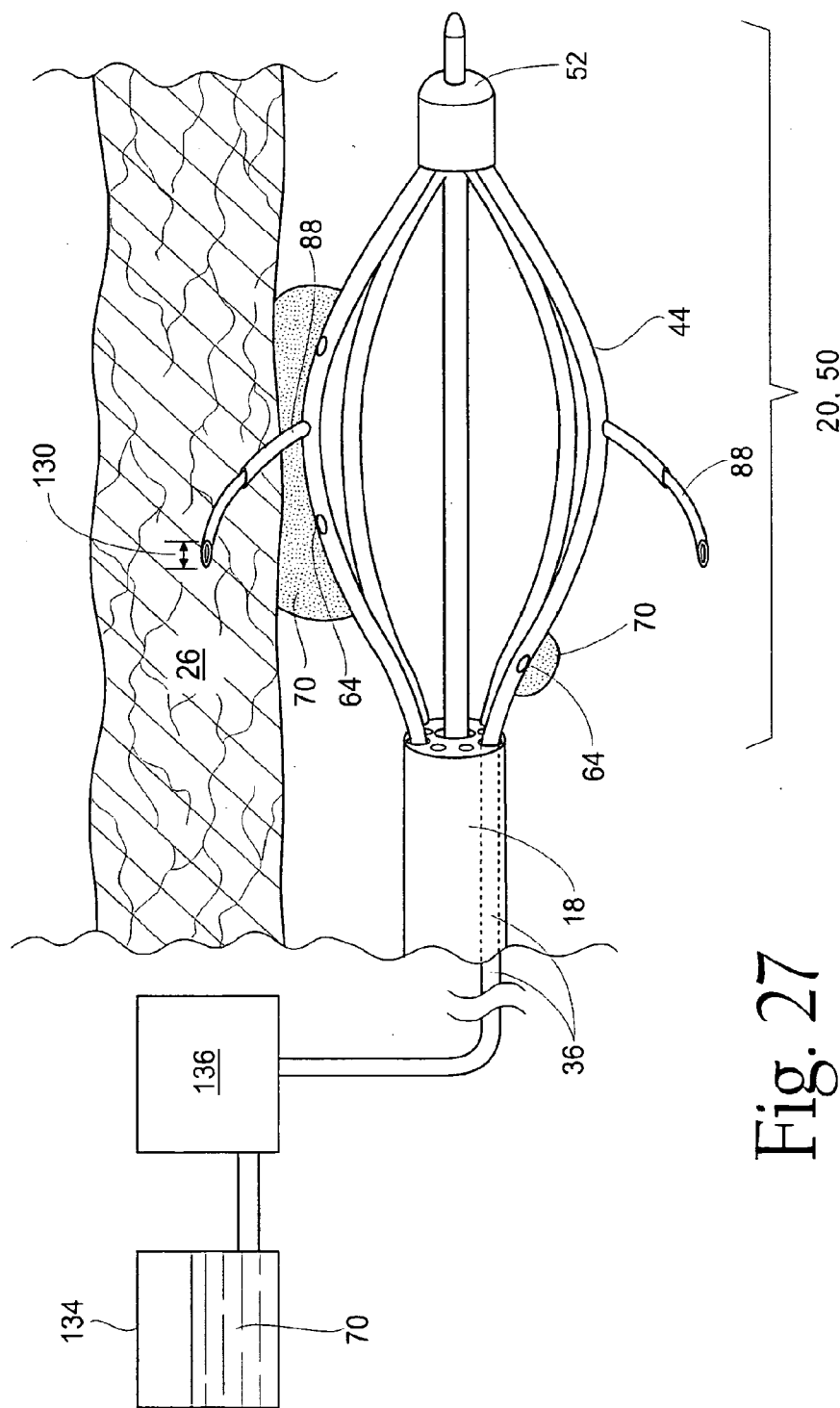

Fig. 26



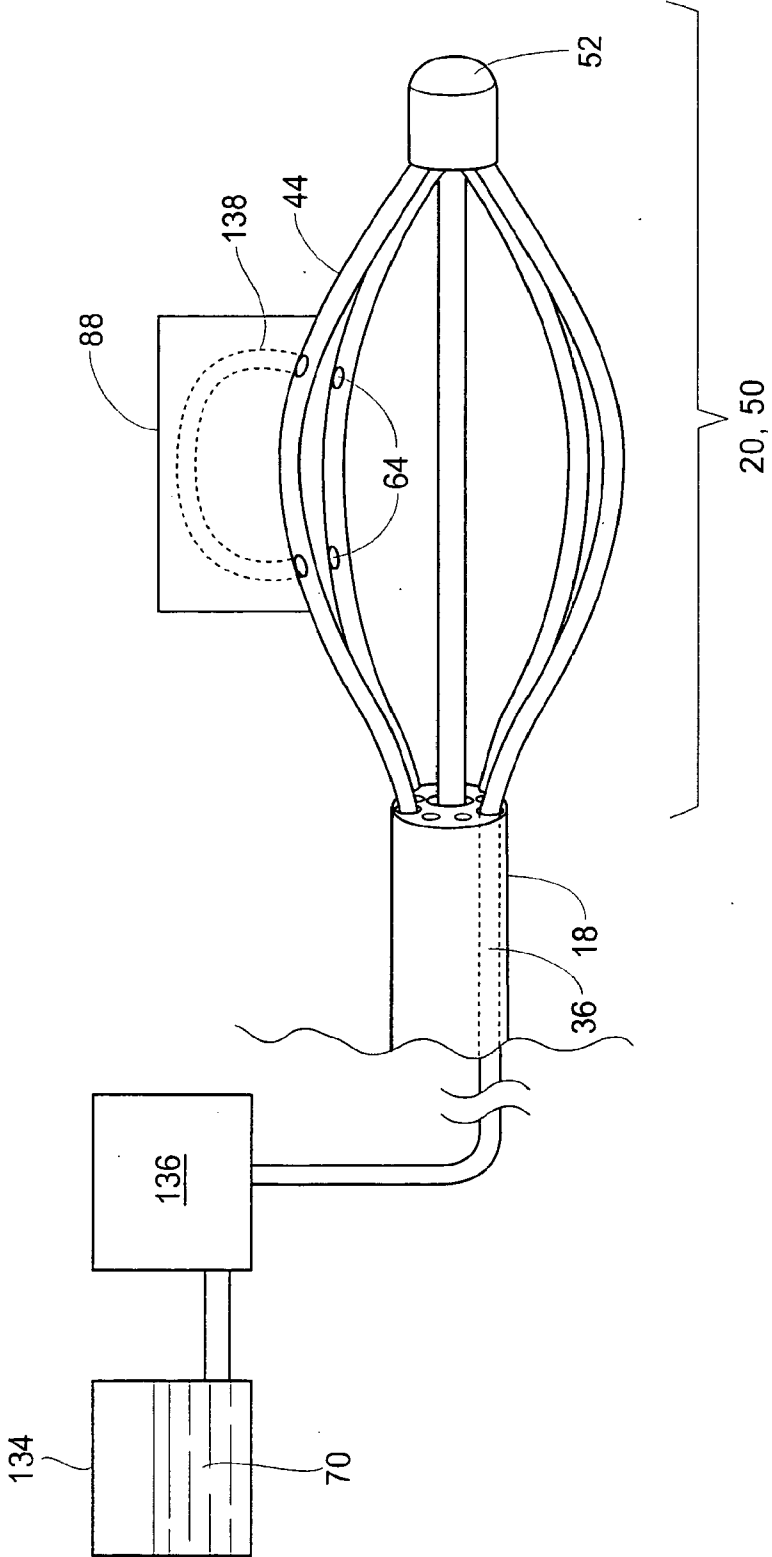

Fig. 28

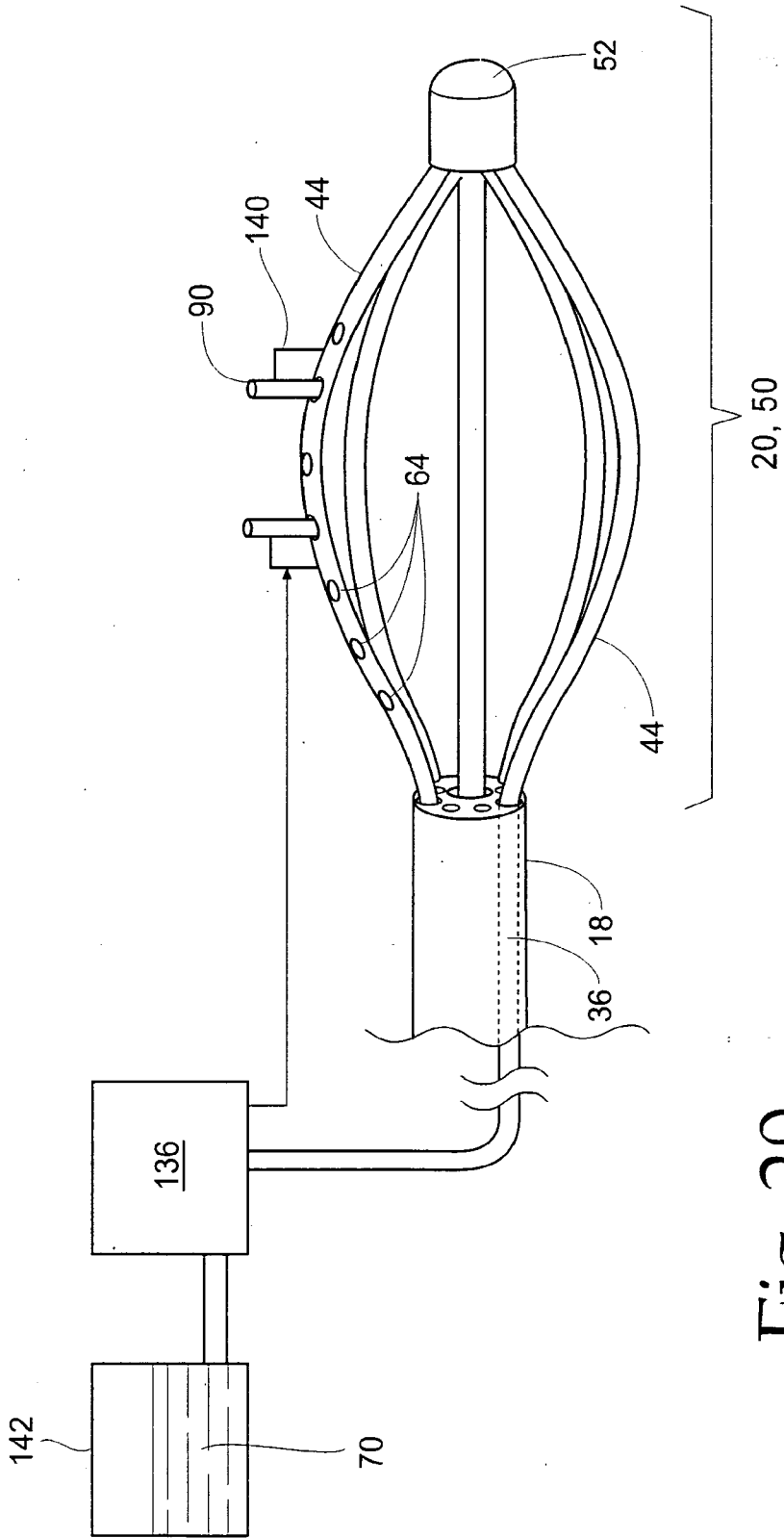

Fig. 29

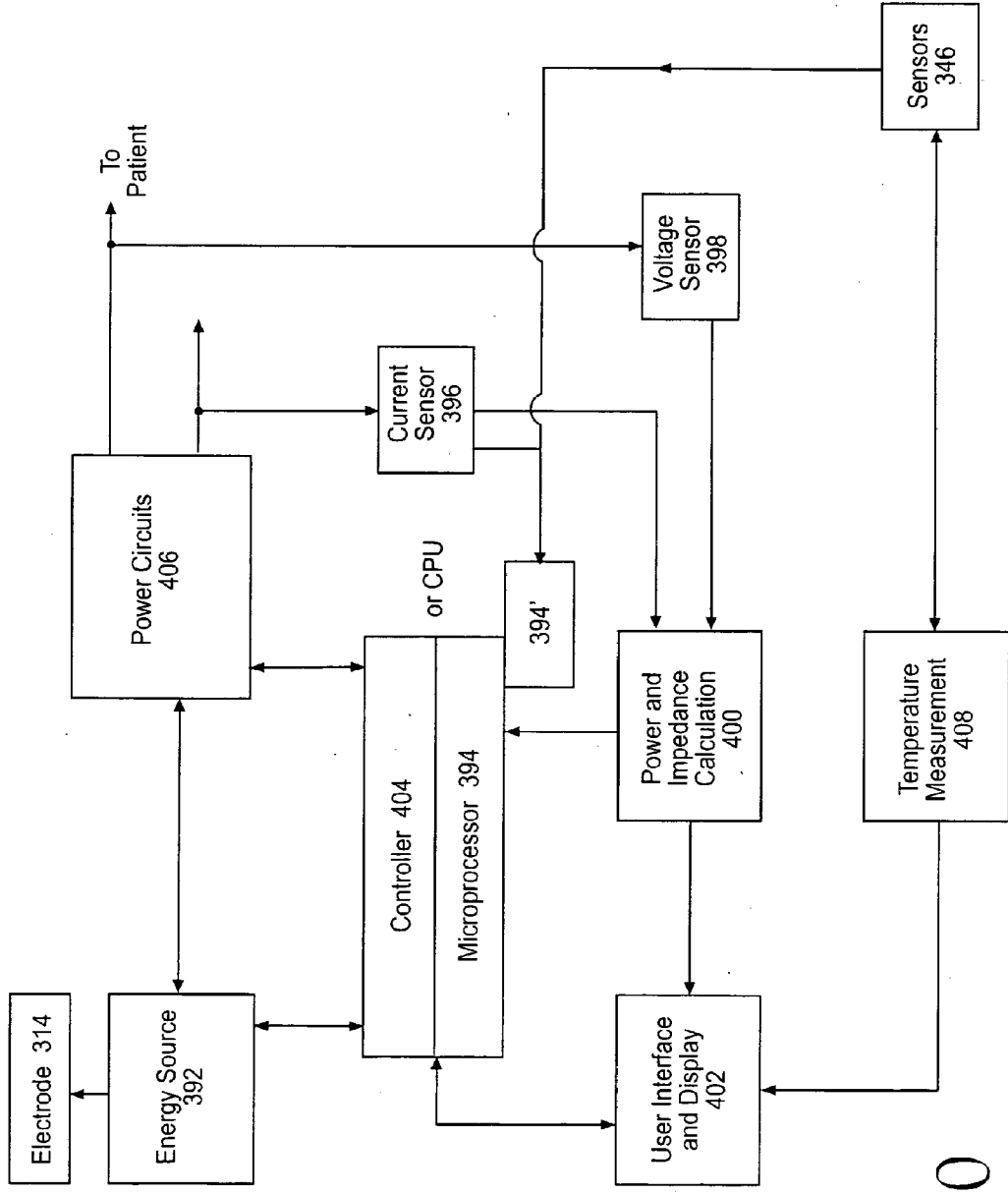

Fig. 30

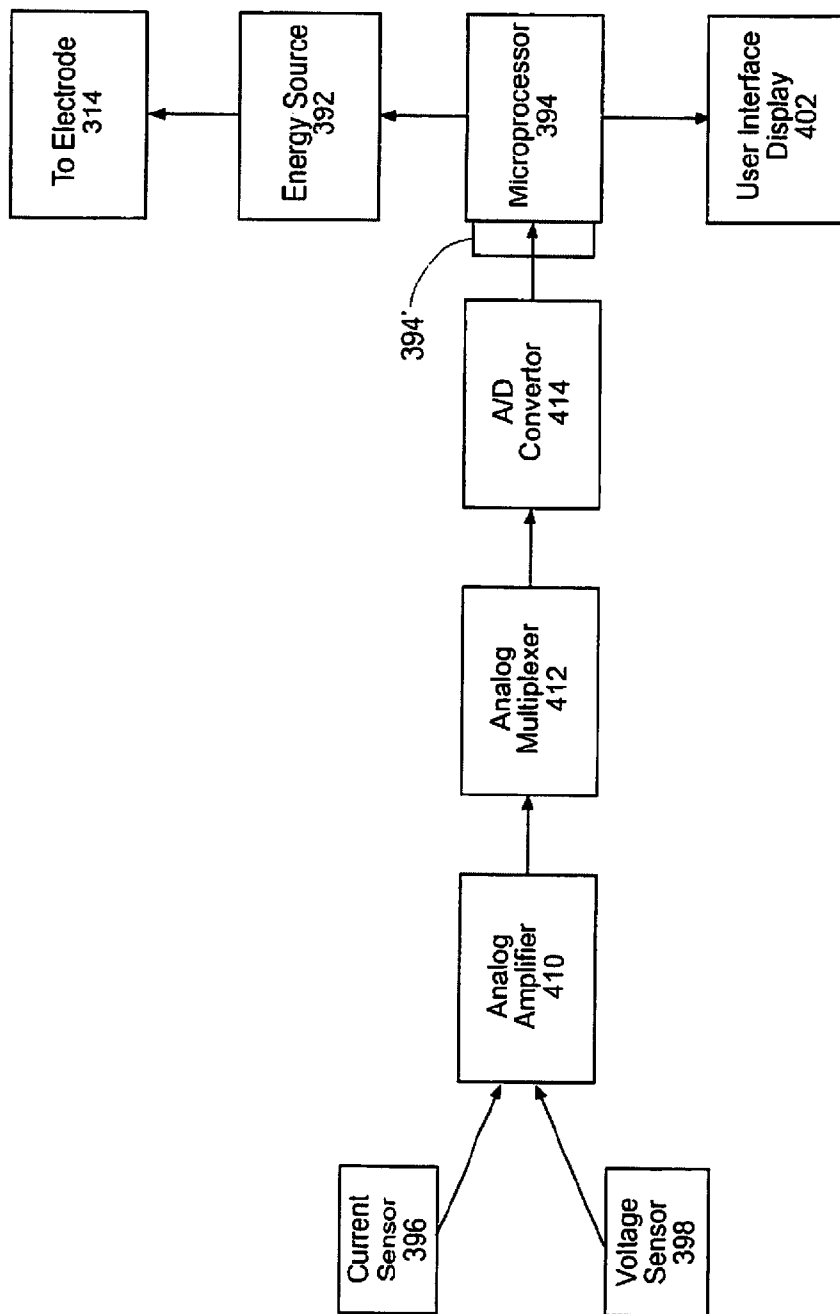

Fig. 31

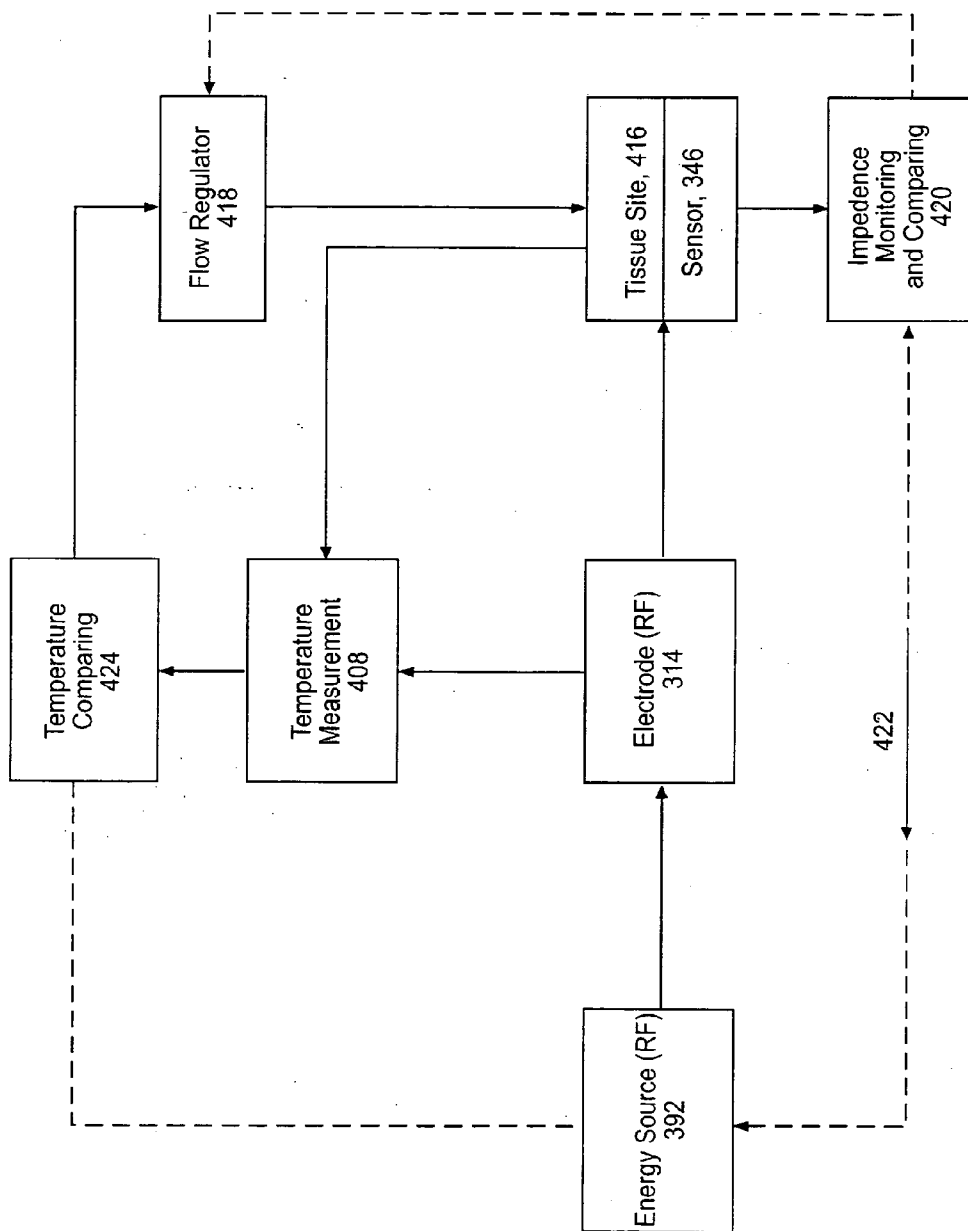

Fig. 32

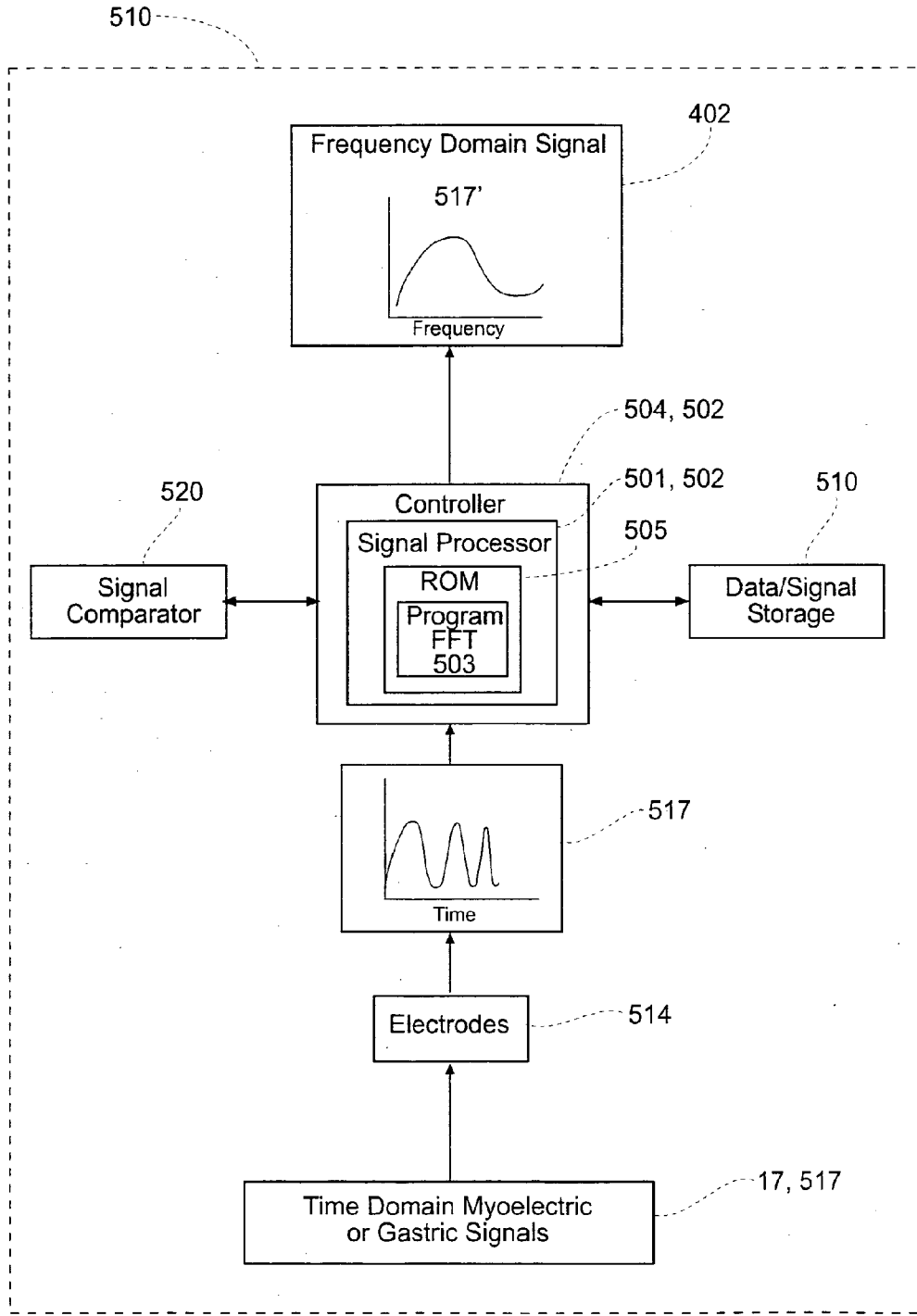

Fig. 33

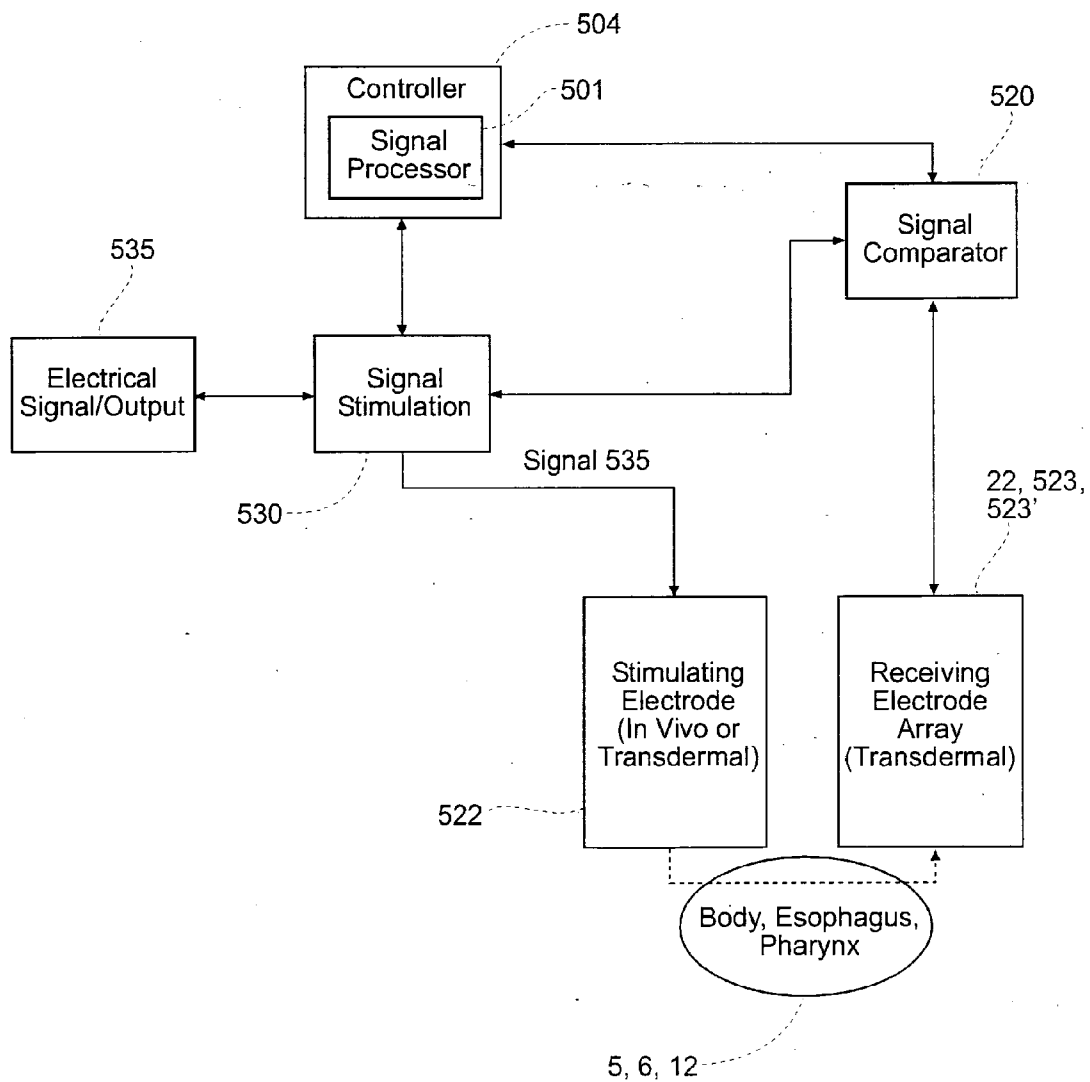

Fig. 34

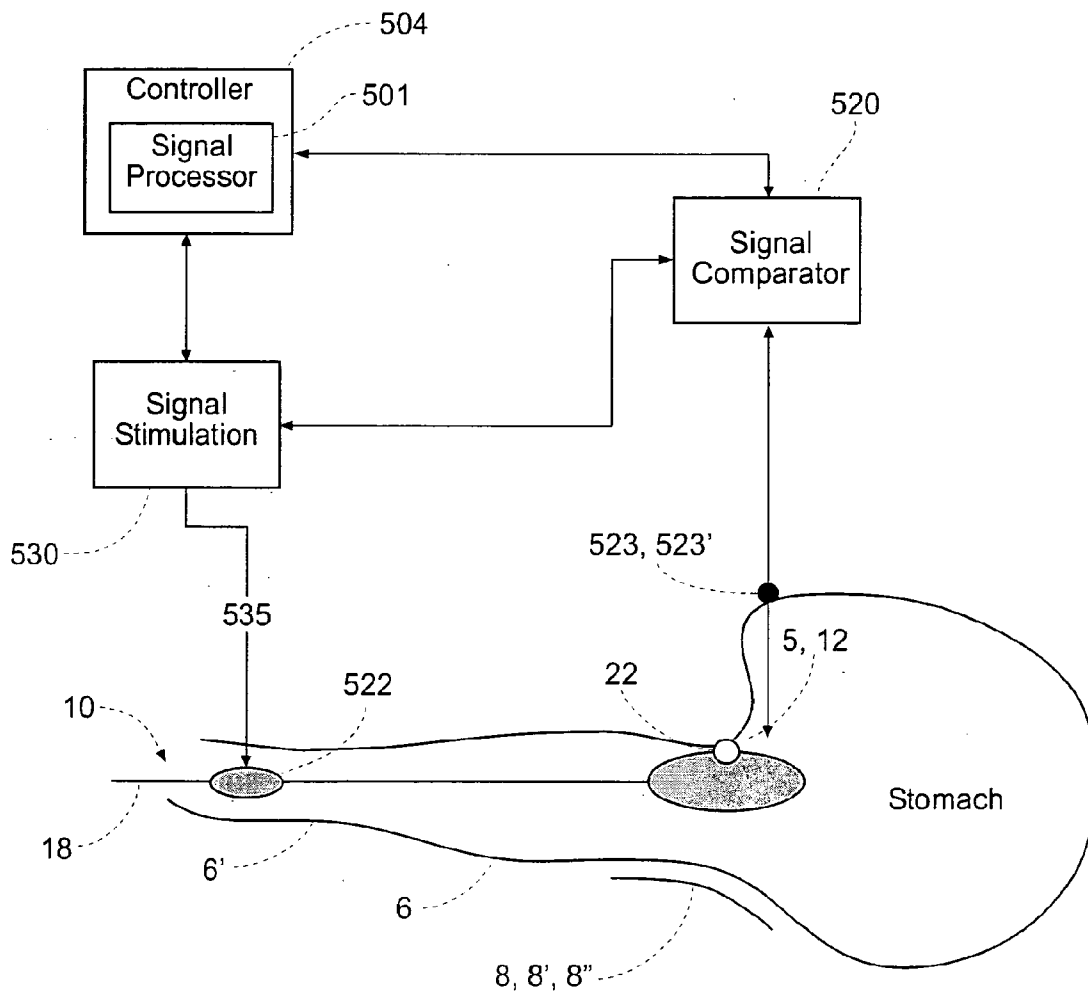

Fig. 35

**SYSTEM FOR TREATING GASTRIC REFLUX
BY TIGHTENING A LOWER ESOPHAGEAL
SPHINCTER**

RELATED APPLICATIONS

[0001] This application is a divisional of co-pending U.S. patent application Ser. No. 11/230,801 filed 20 Sep. 2005, which is a divisional of co-pending U.S. patent application Ser. No. 10/156,505, filed May 28, 2002, which is a continuation of U.S. patent application Ser. No. 09/410,448, filed Oct. 1, 1999, now U.S. Pat. No. 6,405,732, which is a continuation-in-part of U.S. patent application Ser. No. 09/026,086 filed Feb. 19, 1998, now U.S. Pat. No. 6,006,755, all of which are incorporated by reference.

FIELD OF THE INVENTION

[0002] This invention relates generally to a method to treat gastroesophageal reflux, and more particularly the detection and ablation and/or necrosis of gastroesophageal nerves and receptors causing transient relaxation of the lower esophageal sphincter and gastroesophageal reflux.

BACKGROUND OF THE INVENTION

[0003] Gastroesophageal reflux disease (GERD) is a common gastroesophageal disorder in which the stomach contents are ejected into the lower esophagus due to a dysfunction of the lower esophageal sphincter (LES). These contents are highly acidic and potentially injurious to the esophagus resulting in a number of possible complications of varying medical severity. The reported incidence of GERD in the U.S. is as high as 10% of the population (Castell D O; Johnston B T: Gastroesophageal Reflux Disease: Current Strategies For Patient Management. Arch Fam Med, 5(4):221-7; (1996 April)).

[0004] Acute symptoms of GERD include heartburn, pulmonary disorders and chest pain. On a chronic basis, GERD subjects to esophagus to ulcer formation, or esophagitis and may result in more severe complications including esophageal obstruction, significant blood loss and perforation of the esophagus. Severe esophageal ulcerations occur in 20-30% of patients over age 65. Moreover, GERD causes adenocarcinoma, or cancer of the esophagus, which is increasing in incidence faster than any other cancer (Reynolds J C: Influence Of Pathophysiology, Severity, And Cost On The Medical Management Of Gastroesophageal Reflux Disease. Am J Health Syst Pharm, 53(22 Supple 3):S5-12 (1996 Nov. 15)).

[0005] The lower esophageal sphincter is a thickened ring of smooth muscle at the lower end of the esophagus. Normally, the LES is in a state of contraction and functions to keep the acid contents of the stomach from refluxing into the esophagus. In a healthy person the muscle relaxes only during swallowing to allow food to pass and also on average three to four times an hour in phenomenon known as transient lower esophageal sphincter relaxation (TLESR). In a person suffering from GERD, the frequency of TLESR is much higher, rising as high as eight or more times and hour.

[0006] Since the resting tone of the LES is maintained by both myogenic (muscular) and neurogenic (nerve) mechanisms, some believe that abnormal or aberrant electrical signals in the lower esophageal sphincter or surrounding region of the stomach including the cardia can cause the sphincter to spontaneously relax. Such signals may cause a higher than normal frequency of TLESRs allowing acidic stomach con-

tents to be repeatedly ejected into the esophagus and cause the complications described above. Research has shown that unnatural electrical signals in the stomach and intestine can cause reflux events in those organs (Kelly K A, et al: Duodenal-gastric Reflux and Slowed Gastric Emptying by Electrical Pacing of the Canine Duodenal Pacemaker Potential. Gastroenterology. 1977 March; 72(3):429-433). In particular, medical research has found that sites of aberrant electrical activity or electrical foci may be responsible for those signals (Karlstrom L H, et al: Ectopic Jejunal Pacemakers and Enterogastric Reflux after Roux Gastrectomy Effect Intestinal Pacing. Surgery. 1959 September; 106(3): 486-495). Similar aberrant electrical sites in the heart, which cause contractions of the heart muscle to take on life threatening patterns or dysrhythmias, can be identified and treated using mapping and ablation devices as described in U.S. Pat. No. 5,509,419. However, there is no current device or associated medical procedure available for the electrical mapping and treatment of aberrant electrical sites in the LES and stomach as a means for treating GERD.

[0007] GERD is believed to be caused by a combination of conditions that increase the presence of acid reflux in the esophagus. These conditions include transient LES relaxation, decreased LES resting tone, impaired esophageal clearance, delayed gastric emptying, decreased salivation, and impaired tissue resistance.

[0008] Current drug therapy for GERD includes histamine receptor blockers which reduce stomach acid secretion and other drugs which may completely block stomach acid. However, while pharmacologic agents may provide short term relief, they do not address the underlying cause of LES dysfunction.

[0009] Invasive procedures requiring percutaneous introduction of instrumentation into the abdomen exist for the surgical correction of GERD. One such procedure, Nissen fundoplication, involves constructing a new "valve" to support the LES by wrapping the gastric fundus around the lower esophagus. Although the operation has a high rate of success, it is an open abdominal procedure with the usual risks of abdominal surgery including: postoperative infection, herniation at the operative site, internal hemorrhage and perforation of the esophagus or of the cardia. In fact, a recent 10 year, 344 patient study reported the morbidity rate for this procedure to be 17% and mortality 1% (Urschel, J D: Complications Of Antireflux Surgery, Am J Surg 166(1): 68-70; (1993 July)). This rate of complication drives up both the medical cost and convalescence period for the procedure and may exclude portions of certain patient populations (e.g., the elderly and immuno-compromised).

[0010] Efforts to perform Nissen fundoplication by less invasive techniques have resulted in the development of laparoscopic Nissen fundoplication. Laparoscopic Nissen fundoplication, reported by Dallemagne et al. Surgical Laparoscopy and Endoscopy, Vol. 1, No. 3, (1991), pp. 138-43 and by Hindler et al. Surgical Laparoscopy and Endoscopy, Vol. 2, No. 3, (1992), pp. 265-272, involves essentially the same steps as Nissen fundoplication with the exception that surgical manipulation is performed through a plurality of surgical cannula introduced using trocars inserted at various positions in the abdomen.

[0011] Another attempt to perform fundoplication by a less invasive technique is reported in U.S. Pat. No. 5,088,979. In this procedure an invagination device containing a plurality of needles is inserted transorally into the esophagus with the

needles in a retracted position. The needles are extended to engage the esophagus and fold the attached esophagus beyond the gastroesophageal junction. A remotely operated stapling device, introduced percutaneously through an operating channel in the stomach wall, is actuated to fasten the invaginated gastroesophageal junction to the surrounding involuted stomach wall.

[0012] Yet another attempt to perform fundoplication by a less invasive technique is reported in U.S. Pat. No. 5,676,674. In this procedure, invagination is done by a jaw-like device and fastening of the invaginated gastroesophageal junction to the fundus of the stomach is done via a transoral approach using a remotely operated fastening device, eliminating the need for an abdominal incision. However, this procedure is still traumatic to the LES and presents the postoperative risks of gastroesophageal leaks, infection and foreign body reaction, the latter two sequela resulting when foreign materials such as surgical staples are implanted in the body.

[0013] While the methods reported above are less invasive than an open Nissen fundoplication, some still involve making an incision into the abdomen and hence the increased morbidity and mortality risks and convalescence period associated with abdominal surgery. Others incur the increased risk of infection associated with placing foreign materials into the body. All involve trauma to the LES and the risk of leaks developing at the newly created gastroesophageal junction. None provide a means for detecting and treating aberrant electrical sites causing abnormal LES relaxation and gastroesophageal reflux.

[0014] There is a need to provide a method to detect and treat aberrant bioelectric activity of a sphincter and/or a stomach including myoelectric activity. There is another need to provide a method to detect and treat an electrical foci of the aberrant bioelectric activity of a sphincter and/or a stomach. There is a further need to detect and treat an electrically conductive pathway of the aberrant bioelectric activity of a sphincter and/or a stomach.

SUMMARY OF THE INVENTION

[0015] Accordingly, an object of the invention is to provide a method to diagnose and treat sphincters and/or a stomach.

[0016] Another object of the invention is to provide a method to diagnose and treat gastroesophageal reflux disease.

[0017] A further object of the invention is to provide a method to detect and treat bioelectrical activity of a sphincter and/or a stomach causing transient relaxation of the lower esophageal sphincter.

[0018] Yet another object of the invention is to provide a method to detect and treat electrically conductive pathways of bioelectrical activity in a sphincter and/or a stomach causing transient relaxation of the lower esophageal sphincter.

[0019] Still a further object of the invention is to provide a method to detect and treat a nerve pathway in a sphincter and/or a stomach causing transient relaxation of the lower esophageal sphincter.

[0020] Another object of the invention is to provide a method to detect and treat a nerve pathway in a sphincter and/or a stomach causing transient relaxation of the lower esophageal sphincter while preserving a swallowing reflex.

[0021] A further object of the invention is to provide a method to detect and treat a receptor pathway in a sphincter and/or a stomach causing transient relaxation of the lower esophageal sphincter.

[0022] Yet a further object of the invention is to provide a method to create an area of electrical block to bioelectric activity of the lower esophageal sphincter and/or stomach causing transient relaxation of the lower esophageal sphincter.

[0023] These and other objects of the invention are provided in a method of treating a sphincter that provides a sphincter electropotential mapping device with at least one of a mapping electrode or a treatment electrode. The sphincter electropotential mapping device is introduced into at least a portion of the sphincter, the lower esophageal sphincter, stomach, the cardia or the fundus. Bioelectric activity causing a relaxation of the sphincter is detected and energy is delivered from either the mapping electrode or the treatment electrode to treat the bioelectric activity.

[0024] In another embodiment, a method of treating a sphincter that provides a sphincter electropotential mapping device with at least one of a mapping electrode or a treatment electrode. The sphincter electropotential mapping device is introduced into at least a portion of the sphincter, the lower esophageal sphincter, stomach, the cardia or the fundus. The sphincter, lower esophageal sphincter, stomach, cardia or fundus is stimulated to produce a transient relaxation of the sphincter. The portion of the sphincter, lower esophageal sphincter, stomach, cardia or fundus causing a relaxation of the sphincter is identified. Energy is delivered from the sphincter electropotential mapping device to treat the portion of the sphincter, lower esophageal sphincter, stomach, cardia or fundus causing the transient relaxation of the sphincter.

BRIEF DESCRIPTION OF THE DRAWINGS

[0025] FIG. 1 is an illustrated lateral view of the upper GI tract including the esophagus and lower esophageal sphincter, cardia and fundus.

[0026] FIG. 2A is an illustrated lateral view of the upper GI tract including the esophagus and lower esophageal sphincter and the positioning of the sphincter mapping and treatment apparatus in an embodiment of the method of the present invention.

[0027] FIG. 2B is a lateral view of an apparatus, useful with the method of the present invention, illustrating the energy delivery device, power source, controllers, map, display device, and the mapping assembly in an expanded and contracted state.

[0028] FIG. 3 depicts a lateral view of an apparatus, useful with the method of the present invention that illustrates components on the flexible shaft including a proximal fitting, connections and proximal and distal shaft segments.

[0029] FIG. 4A illustrates a lateral view of the basket assembly used in an embodiment of the method of the present invention.

[0030] FIG. 4B is a lateral view that illustrates placement of the mapping electrodes on the basket assembly and their electrical connections to the controller.

[0031] FIG. 5A is a lateral view of the basket assembly that illustrates the range of camber in the basket assembly.

[0032] FIG. 5B is a perspective view illustrating a balloon coupled to the basket assembly.

[0033] FIG. 6A is a lateral view of the junction between the basket arms and the shaft illustrating the pathway used for advancement of a movable wire or the delivery of fluids.

[0034] FIG. 6B is a frontal view of a basket arm in an alternative embodiment of an apparatus, useful with the

method of the present invention, illustrating a track in the arm used to advance the movable wire.

[0035] FIG. 7 is a cross-sectional view of a section of the basket arm illustrating stepped and tapered sections in basket arm apertures.

[0036] FIG. 8 is a lateral view of the basket assembly illustrating the placement of the radial supporting member.

[0037] FIG. 9A is a lateral view of the sphincter mapping and treatment apparatus illustrating the mechanism used in one embodiment of an apparatus, useful with the method of the present invention, to increase the camber of the basket assembly.

[0038] FIG. 9B is a similar view to 9A showing the basket assembly in an increased state of camber.

[0039] FIG. 10 is a lateral view of the sphincter mapping and treatment apparatus, useful with the method of the present invention, illustrating the deflection mechanism.

[0040] FIG. 11A is a lateral view illustrating the use of electrolytic solution to create an enhanced RF electrode.

[0041] FIGS. 11B-11C are lateral views illustrating the use of nerves to conduct RF energy to a desired tissue site.

[0042] FIG. 12 is a lateral view of the basket assembly illustrating the use of needle electrodes.

[0043] FIG. 13 is a lateral view illustrating the use of an insulation segment on the needle electrode to protect an area of tissue from RF energy.

[0044] FIGS. 14A and 14B are lateral views illustrating the placement of needle electrodes into the sphincter wall by expansion of the basket assembly.

[0045] FIG. 15 is a lateral view illustrating placement of needle electrodes into the sphincter wall by advancement of an electrode delivery member out of apertures in the basket arms.

[0046] FIG. 16 is a cross sectional view illustrating the configuration of a basket arm aperture used to select and maintain a penetration angle of the needle electrode into the sphincter wall.

[0047] FIG. 17 is a lateral view illustrating placement of needle electrodes into the sphincter wall by advancement of an electrode delivery member directly out of the distal end of the shaft.

[0048] FIG. 18A is a lateral view illustrating a radial distribution of electrodes on the expandable mapping assembly of an apparatus useful with the method of the present invention.

[0049] FIG. 18B is a lateral view illustrating a longitudinal distribution of electrodes on the expandable mapping assembly useful with the method of the present invention.

[0050] FIG. 18C is a lateral view illustrating a spiral distribution of electrodes on the expandable mapping assembly useful with the method of the present invention.

[0051] FIG. 18D is a lateral view illustrating a radial-longitudinal distribution of electrodes on the expandable mapping assembly useful with the method of the present invention.

[0052] FIG. 19 is a flow chart illustrating the sphincter treatment method of the current invention.

[0053] FIG. 20 is a lateral view of sphincter smooth muscle tissue illustrating electromagnetic foci and pathways for the origination and conduction of aberrant electrical signals in the smooth muscle of the lower esophageal sphincter or other tissue.

[0054] FIG. 21 is a lateral view of a sphincter wall illustrating the infiltration of tissue healing cells into a lesion in the

smooth tissue of a sphincter following treatment with the sphincter treatment apparatus.

[0055] FIG. 22 is a view similar to that of FIG. 21 illustrating shrinkage of the lesion site caused by cell infiltration.

[0056] FIG. 23 is a lateral view of the esophageal wall illustrating the preferred placement of lesions in the smooth muscle layer of an esophageal sphincter.

[0057] FIG. 24 is a lateral view illustrating an ultrasound transducer, ultrasound lens and power source of an embodiment useful with the method of the present invention.

[0058] FIGS. 25A-D are lateral views of the sphincter wall illustrating various patterns of lesions created in an embodiment of the method of the present invention.

[0059] FIGS. 25E-F are lateral views of the sphincter wall illustrating the use of lesions to create an area of electrical block to bioelectrical signals including those causing TLSERS.

[0060] FIG. 25G is a lateral view of the stomach illustrating the various shapes of areas of electrical block to bioelectrical signals.

[0061] FIG. 26 is a lateral view of the sphincter wall illustrating the delivery of cooling fluid to the electrode-tissue interface and the creation of cooling zones.

[0062] FIG. 27 depicts the flow path, fluid connections and control unit employed to deliver fluid to the electrode-tissue interface.

[0063] FIG. 28 depicts the flow path, fluid connections and control unit employed to deliver fluid to the RF electrodes.

[0064] FIG. 29 is an enlarged lateral view illustrating the placement of sensors on the expansion device or basket assembly.

[0065] FIG. 30 depicts a block diagram of the feed back control system that can be used with the sphincter mapping and treatment apparatus.

[0066] FIG. 31 depicts a block diagram of an analog amplifier, analog multiplexer and microprocessor used with the feedback control system of FIG. 30.

[0067] FIG. 32 depicts a block diagram of the operations performed in the feedback control system depicted in FIG. 30.

[0068] FIG. 33 depicts a block diagram of the signal processing system that can be used with the sphincter mapping and treatment apparatus.

[0069] FIG. 34 depicts a block diagram of the transdermal signal stimulation system that can be used with the sphincter mapping and treatment apparatus.

[0070] FIG. 35 depicts a block diagram of an embodiment of a signal stimulation system that can be used to evoke and monitor a swallowing reflex with one embodiment of the sphincter mapping and treatment apparatus.

DETAILED DESCRIPTION

[0071] FIG. 1 depicts the anatomy of the lower esophageal sphincter (LES) 5 and surrounding structures. The LES 5 consists of a thickened ring like structure of smooth muscle at the junction between the esophagus 6 and the stomach 7. The muscles of the LES 5 consist of both circumferential and longitudinal oriented muscle. Normally, the LES 5 is in a state of contraction, and functions to keep the acidic contents of the stomach from refluxing into the esophagus (via the generation of a pressure of 20-30 mm hg over stomach pressure). However during swallowing and also every three to four times and hour the LES relaxes for several seconds or longer in a phenomena known as transient lower esophageal sphincter

relaxation (TLESR). In a person suffering from GERD, the frequency of TLESR is much higher rising as high as eight or more times in an hour.

[0072] The LES 5 is enervated with autonomic nerve fibers 8 that perform several functions. These include maintaining a resting tone to keep the LES in a state of contraction; and relaxing the LES to allow swallowing, accommodate pressure increases in the stomach and to initiate TLESRs. The nerve fibers include efferent fibers 8" going from the brain and/or the upper esophagus 6' to the LES and afferent fibers 8' going from portions of the stomach to the LES as well as from the LES to the brain. Efferent fibers 8" include vagus nerves, while afferent nerve fibers 8' include those leading from gastric receptors 9 such as the mechanoreceptors 9' and chemoreceptors 9" through the cardia 7' to the LES. Stimulation from one or both of these receptors 9, (due to stretching of stomach from ingested food, or a change in stomach pH) is thought to be a possible cause of LES relaxation. Therefore one embodiment of the invention described herein for treating GERD involves the ablation and/or electrical block of the nerve fibers and/or pathways leading from gastric receptors 9 including the mechanoreceptors 9' and chemoreceptors 9" to the LES 5. In various embodiments, the blockage can be achieved by ablating the fibers 8 and/or receptors 9 via the application of heat and/or ablative agents (e.g. ethanol, quinolinic acid, glutamate, botoxin or other neurotoxin known in the art) to attenuate and/or eliminate the nerve impulse going from these receptors to the LES or surrounding structures. The electrical block or ablation can be done anywhere along the pathway from the receptor to the LES but in a preferred embodiment, the ablation is done in or near the cardia and/or LES. In various embodiments, the block is achieved by the delivery of energy in the form of heat to create lesions at or near the desired nerve pathway or receptor. In embodiments using electromagnetic energy (e.g. electrical, RF and the like) described herein, the time pathway itself can be used as conduit to deliver ablative energy to the target treatment site. In various embodiments, the block can be achieved without injury of or damage of nerves involved in the swallowing reflex including the vagus and other efferent nerves 8". This can be achieved via the use of cooling and other means described herein. In another embodiment, this is accomplished through the use of a signal stimulation device/means described here in, to induce and monitor the presence of the swallowing reflex before during or after the delivery of energy to the treatment site 12.

[0073] FIG. 2A depicts one embodiment of a sphincter mapping and treatment apparatus 10 that is used to both map and treat gastric bioelectric activity causing transient relaxation of the sphincter and subsequent gastro-esophageal reflux. Specifically, apparatus 10 delivers energy to a treatment site 12 to produce lesions 14 in a sphincter 16, such as the lower esophageal sphincter 5. Apparatus 10 comprises a flexible elongated shaft 18, also called shaft 18 or catheter 18, coupled to an expandable mapping assembly 20, in turn coupled with one or more mapping electrodes 22 which can also serve as treatment electrodes 22 capable of delivering energy to treatment site 12.

[0074] Expandable mapping assembly 20 establishes a three dimensional array of mapping electrodes 22. In use, the expandable mapping assembly 20 records the activation times, the distribution, and the waveforms of the myoelectric or neuroelectric action potentials in sphincter 16, such as the LES 5 and adjoining structures that trigger aberrant and/or

transient relaxation of smooth muscle tissue in the sphincter or LES. Suitable materials for mapping electrodes 22 include gold, platinum, silver, copper and alloys and combinations thereof, as well as other conductors known to those skilled in the art.

[0075] Referring now to FIG. 2a and FIG. 2b, mapping electrodes 22 are configured to be coupled to a controller 24. Controller 24 receives and processes the potentials recorded by the mapping electrodes 22 on expandable mapping assembly 20 and produces an electropotential map 27, also called a map 27, of the bioelectric signals 17, including myoelectric and neuroelectric signals 17, in sphincter 16. Controller 24 and electropotential map 27 are used by the physician to diagnose abnormalities and pathologies within sphincter 16 and adjoining structures which will be further discussed herein. Controller 24 can be coupled to an output or display device 29 that can include a cathode ray tube, liquid crystal display, passive or active matrix flat screen display or printer and the like.

[0076] Myoelectric and neuroelectric signals 17 can include nerve action potentials: both efferent and afferent; and depolarization signals in smooth and skeletal muscle.

[0077] Expandable mapping assembly 20 has a central longitudinal axis 28 and is moveable between contracted and expanded positions substantially there along. This can be accomplished by a ratchet mechanism and the like as is known to those skilled in the art and by the use of other mechanisms disclosed herein. The expandable mapping assembly 20 is further configured to be positionable in a sphincter 16 such as the LES or adjacent anatomical structure, such as the cardia 7' of the stomach. Once positioned within the desired sphincter 16, the operating physician causes expandable mapping assembly 20 to expand to an expanded stationary position within the sphincter so that mapping electrodes 22 thereof engage sphincter wall 26 for sensing and detecting electrical energy or impulses therefrom. At least portions of sphincter mapping and treatment apparatus 10 may be sufficiently radiopaque in order to be visible under fluoroscopy and/or sufficiently echogenic to be visible under ultrasonography. Also, as will be discussed herein, sphincter mapping and treatment apparatus 10 can include visualization capability including, but not limited to, a viewing scope, an expanded eyepiece, fiber optics, video imaging and the like.

[0078] Referring now to FIG. 2B, shaft 18 is configured to be coupled to expandable mapping assembly 20 and has sufficient length to position expandable mapping assembly 20 in the LES and/or stomach using a transoral approach. Typical lengths for shaft 18 include, but are not limited to, a range of 40-180 cm. In various embodiments, shaft 18 is flexible, articulated and steerable and can contain fiber optics (including illumination and imaging fibers), fluid and gas paths, and sensor and electronic cabling. In one embodiment, shaft 18 can be a multi-lumen catheter, as is well known to those skilled in the art.

[0079] In another embodiment of the invention, an introducing member 21, also called an introducer, is used to introduce sphincter mapping and treatment apparatus 10 into the LES including transoral introduction through the mouth and the throat. Introducer 21 can also function as a sheath for expandable mapping assembly 20 to keep it in a nondeployed or contracted state during introduction into the LES. In various embodiments, introducer 21 is flexible, articulated and steerable, and contains a continuous lumen of sufficient diam-

eter to allow the advancement of sphincter mapping and treatment apparatus 10 within. Typical diameters for introducer 21 include 0.1 to 2 inches, while typical lengths include 40-180 cm. Suitable materials for introducer 21 include wire-reinforced plastic tubing as is well known to those skilled in the art. Alternatively, the catheter 18 may be deployed over a guide wire through the patient's mouth and pharynx, and into the esophagus without use of an introducer 21. Still alternatively, catheter 18 may be passed through the patient's mouth and pharynx, and into the esophagus without use of either a guide wire or introducer.

[0080] Referring now to FIGS. 3, 4A and 4B, the flexible elongate shaft 18 is circular in cross section and has proximal and distal extremities (also called ends) 30 and 32. Shaft 18 may also be coupled at its proximal end 30 to a proximal fitting 34, also called a handle, used by the physician to manipulate sphincter mapping and treatment apparatus 10 to reach treatment site 12. Shaft 18 may have one or more shaft lumens 36 that extend the full length of shaft 18, or part way from shaft proximal end 30 to shaft distal end 32. Shaft lumens 36 may be used as paths for catheters, guide wires, pull wires, insulated wires and cabling, fluid and optical fibers. Shaft lumens 36 are connected to and/or accessed by connections 38, also called connector 38, on or adjacent to proximal fitting 34. Connections 38 can include luer-lock, swage and other mechanical varieties well known to those skilled in the art. Connections 38 can also include electrical connections 38' which can include lemo-connectors, micro connectors and other electrical varieties well known to those skilled in the art. Additionally, connectors 38 can include opto-electronic connections 38" which allow optical and electronic coupling of optical fibers and/or viewing scopes to illuminating sources, eye pieces, video monitors and the like. In various embodiments, shaft 18 may stop at the proximal extremity 40 of expandable mapping assembly 20 or extend to, or past, the distal extremity 42 of expandable mapping assembly 20. Suitable materials for shaft 18 include, but are not limited to, polyethylenes, polyurethanes, Pebax®, polyimides, nylons, copolymers thereof and other medical plastics known to those skilled in the art.

[0081] Referring now to FIG. 4A, in one embodiment of the present invention, expandable mapping assembly 20 comprises one or more elongated arms 44 that are joined at their proximal arm ends 46 and distal arm ends 48 to form a basket assembly 50. Proximal arm end 46 is attached to a supporting structure, which can be the distal end 32 of shaft 18 or a proximal cap 51. Likewise, distal arm end 48 is also attached to a supporting structure which can be a distal basket cap 52 or shaft 18. Attached arms 44 may form a variety of geometric shapes including, but not limited to, curved, rectangular, trapezoidal and triangular. Arms 44 can have a variety of cross sectional geometries including, but not limited to, circular, rectangular and crescent-shaped. Also, arms 44 are of a sufficient number (two or more), and have sufficient spring force (0.01 to 0.5 lbs. force) so as to collectively exert adequate force on sphincter wall 26 to sufficiently open and efface the folds of sphincter 16 to allow treatment with sphincter mapping and treatment apparatus 10, while preventing herniation of sphincter wall 26 into the spaces 53 between arms 44. Suitable materials for arms 44 include, but are not limited to, spring steel, stainless steel, superelastic shape memory metals such as nitinol or wire-reinforced plastic tubing as is well known to those skilled in the art. Also, arms 44 can be con-

figured to have a selectable spring constant for parallel or perpendicular deflection to the longitudinal axis 28 of arm 44.

[0082] Referring now to FIG. 4B, a plurality of spaced apart mapping electrodes 22 are carried by each arm 44 for engaging sphincter wall 26 and are electrically coupled by a conductor 23 to a multiplexer chip 25 for transmitting signals sensed thereby to controller 24 via electrical connections 38'. Various geometric patterns for placement of mapping electrodes 22 on basket assembly 50 or expandable mapping assembly 20 are disclosed later herein. Multiplexer chip 25 transmits only a selected one of the electrode signals at a time to the controller 24, subject to switching signals that controller 24 generates. The switching signals of controller 24 serve to multiplex the electrode signals through electrical connector 38'. This reduces the number of electrical pathways required through shaft lumen 36. In various embodiments, conductor 23 can be an insulated lead wire as is well known to those skilled in the art.

[0083] In various embodiments, expandable mapping assembly 20 or basket assembly 50 may also be coupled to one or more energy delivery devices 88, also called electrodes, coupled to power source 56. Energy delivery devices 88 are used to deliver energy to treatment site 12 to produce lesions 14. Expandable mapping assembly 20 is further configured to facilitate the positioning of energy delivery devices 88, to a selectable depth in a sphincter wall 26 or adjoining anatomical structure. In one embodiment mapping electrodes 22 can also be used as energy delivery devices.

[0084] Referring to FIG. 5A, arms 44 can have an outwardly bowed shaped memory for expanding the basket assembly into engagement with sphincter wall 26 with the amount of bowing, or camber 54 being selectable from a range 0 to 2 inches from longitudinal axis 28 of basket assembly 50. For the case of a curve-shaped arm 44', expanded arms 44' are circumferentially and symmetrically spaced-apart.

[0085] In another embodiment shown in FIG. 5B, an expansion device 55, which can be a balloon, is coupled to an interior or exterior of basket assembly 50. Balloon 55 is also coupled to and inflated by shaft lumen 36 using gas or liquid. In various other embodiments (not shown), arms 44 may be asymmetrically spaced and/or distributed on an arc less than 360 degrees. Also, arms 44 may be preshaped at time of manufacture or shaped by the physician.

[0086] Referring now to FIG. 6A, arms 44 may also be solid or hollow with a continuous lumen 58 that may be coupled with shaft lumens 36. These coupled lumens provide a path for the delivery of a fluid or electrode delivery member 60 from shaft 18 to any point on expandable mapping assembly 20. In various embodiments electrode delivery member 60 can be an insulated wire, an insulated guide wire, a plastic-coated stainless steel hypotube with internal wiring or a plastic catheter with internal wiring, all of which are known to those skilled in the art. As shown in FIG. 6B, arms 44 may also have a partially open channel 62, also called a track 62, that functions as a guide track for electrode delivery member 60. Referring back to FIG. 6A, arms 44 may have one or more apertures 64 at any point along their length that permit the controlled placement of electrodes 88 at or into sphincter wall 26. Referring now to FIG. 7, apertures 64 may have tapered sections 66 or stepped sections 68 in all or part of their length, that are used to control the penetration depth of electrodes 88 into sphincter wall 26. Referring back to FIG. 6A, apertures 64 in combination with arm lumens 58 and shaft lumens 36 may be used for the delivery of a cooling solution 70 or

electrolytic solution 72 to treatment site 12 as described herein. Additionally, arms 44 can also carry a plurality of longitudinally or radially spaced apart radiopaque and or echogenic markers or traces, not shown in the drawings, formed of suitable materials to permit viewing of basket assembly 50 via fluoroscopy, ultrasonography and the like. Suitable radiopaque materials include platinum or gold, while suitable echogenic materials include gas filled micro-particles as described in U.S. Pat. Nos. 5,688,490 and 5,205,287. Arms 44 may also be color-coded to facilitate their identification via visual medical imaging methods and equipment, such as endoscopic methods, which are well known to those skilled in the art.

[0087] In another embodiment of the present invention, a radial supporting member 74 (also called a strut 74) is attached to two or more arms 44. Radial supporting member 74 can be attached to arms 44 along a circumference of basket assembly 50 as shown in FIG. 8. Apertures 64 can extend through radial supporting member 74 in one or more places. Radial supporting member 74 serves the following functions: i) facilitates opening and effacement of the folds of sphincter 16, ii) enhances contact of apertures 64 with sphincter wall 26; and iii) reduces or prevents the tendency of arms 44 to bunch up. The cross sectional geometry of radial supporting member 74 can be rectangular or circular, though it will be appreciated that other geometries are equally suitable.

[0088] In one embodiment shown in FIGS. 9A and 9B, arms 44 are attached to distal basket cap 52 that in turn, moves freely over shaft 18, but is stopped distally by shaft cap 78. One or more pull wires 80 are attached to distal basket cap 52 and also to a movable fitting 82 in proximal fitting 34 of sphincter mapping and treatment apparatus 10. When pull wire 80 is pulled back by movable fitting 82, the camber 54 of basket assembly 50 increases to 54', increasing the force and the amount of contact applied by basket assembly 50 to sphincter wall 26 or an adjoining structure. Basket assembly 50 can also be deflected from side to side using deflection mechanism 84. This allows the physician to remotely point and steer the basket assembly within the body. In one embodiment shown in FIG. 10, deflection mechanism 84 includes a second pull wire 80' attached to shaft cap 78 and also to a movable slide 86 integral to proximal fitting 34.

[0089] Turning now to a discussion of energy delivery, suitable power sources 56 and energy delivery devices 88 that can be employed in one or more embodiments of the invention include: (i) a radio-frequency (RF) source coupled to an RF electrode, (ii) a coherent source of light coupled to an optical fiber, (iii) an incoherent light source coupled to an optical fiber, (iv) a heated fluid coupled to a catheter with a closed channel configured to receive the heated fluid, (v) a heated fluid coupled to a catheter with an open channel configured to receive the heated fluid, (vi) a cooled fluid coupled to a catheter with a closed channel configured to receive the cooled fluid, (vii) a cooled fluid coupled to a catheter with an open channel configured to receive the cooled fluid, (viii) a cryogenic fluid, (ix) a resistive heating source, (x) a microwave source providing energy from 915 MHz to 2.45 GHz and coupled to a microwave antenna, (xi) an ultrasound power source coupled to an ultrasound emitter, wherein the ultrasound power source produces energy in the range of 300 KHZ to 3 GHz, or (xii) a microwave source. For ease of discussion for the remainder of this application, the power source utilized is an RF source and electrode 88 is one or more RF electrodes 88. However, all of the other herein mentioned

power sources and mapping electrodes are equally applicable to sphincter mapping and treatment apparatus 10.

[0090] When the power source is an RF energy source, power source 56, which will now be referred to as RF power source 56, supplies radio frequency energy, e.g., having a frequency in the range of about 400 kHz to about 10 MHz. Power source 56 may have multiple channels, delivering separately modulated power to each electrode 88. This reduces preferential heating that occurs when more energy is delivered to a zone of greater conductivity and less heating that occurs around RF electrodes 88 which are placed into less conductive tissue. If the level of tissue hydration or the blood infusion rate in the tissue is uniform, a single channel RF power source 56 may be used to provide power for generation of lesions 14 relatively uniform in size.

[0091] For embodiments using RF energy, RF electrode 88 may operated in either bipolar or a monopolar mode with a ground pad electrode. In a monopolar mode of delivering RF energy, a single electrode 88 is used in combination with an indifferent electrode patch 89 (or ground pad electrode) that is applied to the body to form the other electrical contact and complete an electrical circuit. Bipolar operation is possible when two or more RF electrodes 88 are used. Multiple RF electrodes 88 may be used. These electrodes may be cooled as described herein. RF electrodes 88 can be attached to electrode delivery member 60 by the use of soldering methods which are well known to those skilled in the art. Suitable solders include Megabond Solder supplied by the Megatrade Corporation (Milwaukee, Wis.).

[0092] Suitable electrolytic solutions 72 include saline, solutions of calcium salts, potassium salts, and the like. Electrolytic solutions 72 enhance the electrical conductivity of the targeted tissue at the treatment site 12. When a highly conductive fluid such as electrolytic solution 72 is infused into tissue the electrical resistance of the infused tissue is reduced, in turn, increasing the electrical conductivity of the infused tissue. As a result, there will be little tendency for tissue surrounding electrode 88 to desiccate (a condition described herein that increases the electrical resistance of tissue) resulting in a large increase in the capacity of the tissue to carry RF energy. Referring to FIG. 11A, a zone of tissue which has been heavily infused with a concentrated electrolytic solution 72 can become so conductive as to actually act as an enhanced electrode 88'. The effect of enhanced electrode 88' is to increase the amount of current that can be conducted to the treatment site 12, making it possible to heat a much greater volume of tissue in a given time period.

[0093] Referring now to FIGS. 11B and 11C, in other embodiments selected nerve fibers 8 can be used as an electrode or conduction path to conduct RF energy to a desired treatment site 12. In these and related embodiments, RF electrode 88 is positioned on or adjacent a nerve fiber 8 (preferably an afferent fiber 8') so as to electrically couple the RF electrode to the nerve fiber. RF energy is then conducted along nerve 8 to create a lesion 14 at some selected distance from the RF electrode 88 and or sphincter mucosal surface 16' of sphincter 16. Preferably this distance is 1 to 5 mm beneath the surface 16'. Parameters that can be used to control the distance of the lesion include one or more of the following: use of cooling a fluid (e.g. flow rate, temperature etc.), the RF power (e.g. wattage) level delivered to the electrode, duration of power delivery and total energy delivered (e.g. joules), nerve type, and nerve thickness. The use of nerves 8 to conduct RF energy presents the distinct advantage of being able

to precisely control the delivery of energy to a desired treatment site to produce one or more lesions **14** via ohmic heating, while minimizing heating and injury to nearby non selected tissue **12'**. In one embodiment shown in FIG. **11C**, energy is delivered along nerve fiber **8'** to produce a first or distal lesion **14'** at distal position relative to the RF electrode **88**. More proximal tissue can be protected via the use of a cooling solution **70** described herein. Continued delivery of RF energy and/or the attenuation of cooling, then results in the development of an expanded or second lesion **14''** (which can be continuous or contiguous with the first lesion **14'**) starting at the more distal portions of the nerve adjacent the distal lesion **14'** with subsequent travel of the lesion in a proximal direction along the nerve **8** to the more proximal portions near or adjacent electrode **88**.

[0094] In this way, one or more nerve fibers **8** can be used as an energy conduit and/or extended energy delivery device **88''** to create multiple lesions in sphincter **16** including lesions both in submucosal muscle and nerve tissue in a single treatment session without having to reposition the energy delivery device. The creation of such multiple and/or continuous nerve and muscle lesions **14', 14''** presents the further advantage of both tightening the sphincter **16** and creating areas of electrical block to minimize and/or eliminate TLSERS in a single delivery of energy and/or treatment session.

[0095] In various embodiments, RF electrodes **88** can have a variety of shapes and sizes. Possible shapes include, but are not limited to, circular, rectangular, conical and pyramidal. Electrode surfaces can be smooth or textured and concave or convex. The conductive surface area of electrode **88** can range from 0.1 mm² to 100 cm². It will be appreciated that other geometries and surface areas may be equally suitable. Other possible geometries include curved (forward or retrograde), spiral and oval.

[0096] In one embodiment, RF electrodes **88** can be in the shape of needles and of sufficient sharpness and length to penetrate into the smooth muscle of the esophageal wall, sphincter **16** or other anatomical structure. In this embodiment shown in FIGS. **12** and **13**, needle electrodes **90** are attached to arms **44** and have an insulating layer **92**, covering an insulated segment **94** except for an exposed segment **95**. For purposes of this disclosure, an insulator or insulation layer is a barrier to either thermal, RF or electrical energy flow. Insulated segment **94** is of sufficient length to extend into sphincter wall **26** and minimize the transmission of RF energy to a protected site **97** near or adjacent to insulated segment **94** (see FIG. **13**). Typical lengths for insulated segment **94** include, but are not limited to, 1-4 mm. Suitable materials for needle electrodes **90** include, but are not limited to, **304** stainless steel and other stainless steels known to those skilled in the art. Suitable materials for insulating layer **92** include, but are not limited to, polyimides and polyamides.

[0097] During introduction of sphincter mapping and treatment apparatus **10**, basket assembly **50** is in a contracted state. Once sphincter mapping and treatment apparatus **10** is properly positioned at the treatment site **12**, needle electrodes **90** are deployed by expansion of basket assembly **50**, resulting in the protrusion of needle electrodes **90** into the smooth muscle tissue of sphincter wall **26** (refer to FIGS. **14A** and **14B**). The depth of needle penetration is selectable from a range of 0.5 to 5 mm and is accomplished by indexing movable fitting **82** so as to change the camber **54** of arm **44** in fixed increments that

can be selectable in a range from 0.1 to 4 mms. Needle electrodes **90** are coupled to power source **56** via insulated wire **60**.

[0098] In another embodiment of sphincter mapping and treatment apparatus **10** shown in FIG. **15**, needle electrodes **90** are advanced out of apertures **64** in basket arms **44** into the smooth muscle of the esophageal wall or other sphincter **16**. In this case, needle electrodes **90** are electrically coupled to RF power source **56** by electrode delivery member **60**. In this embodiment, the depth of needle penetration is selectable via means of tapered sections **66** or stepped sections **68** located in apertures **64**. Referring now to FIG. **16**, apertures **64** and needle electrodes **90** are configured such that the penetration angle **96** (also called an emergence angle **96**) of needle electrode **90** into sphincter wall **26** remains sufficiently constant during the time needle electrode **90** is being inserted into sphincter wall **26**, such that there is no tearing or unnecessary trauma to sphincter wall tissue. This is facilitated by the selection of the following parameters and criteria: i) the emergence angle **96** of apertures **64** which can vary from 1 to 90°, ii) the arc radius **98** of the curved section **100** of aperture **64** which can vary from 0.001 to 2 inch, iii) the amount of clearance between the aperture inner diameter **102** and the needle electrode outside diameter **103** which can vary between 0.001" and 0.1"; and, iv) use of a lubricious coating on electrode delivery member **60** such as a Teflon® or other coatings well known to those skilled in the art including liquid silicone coatings. Also in this embodiment, insulated segment **94** can be in the form of a sleeve that may be adjustably positioned at the exterior of needle electrode **90**.

[0099] In another alternative embodiment shown in FIG. **17**, electrode delivery member **60** with attached needle electrodes **90**, can exit from shaft lumen **36** at distal shaft end **32** and be positioned into contact with sphincter wall **26**. This process may be facilitated by use of a hollow guiding member **101**, known to those skilled in the art as a guiding catheter, through which electrode delivery member **60** is advanced. Guiding catheter **101** may also include tapered sections **66** or stepped sections **68** at its distal end to control the depth of penetration of needle electrode **90** into sphincter wall **26**.

[0100] RF energy flowing through tissue causes heating of the tissue due to absorption of the RF energy by the tissue and ohmic heating due to electrical resistance of the tissue. This heating can cause injury to the affected cells and can be substantial enough to cause cell death, a phenomenon also known as cell necrosis. For ease of discussion for the remainder of this application, cell injury will include all cellular effects resulting from the delivery of energy from electrode **88** up to, and including, cell necrosis. Cell injury can be accomplished as a relatively simple medical procedure with local anesthesia. In one embodiment, cell injury proceeds to a depth of approximately 1-4 mm from the surface of the mucosal layer of sphincter **16** or that of an adjoining anatomical structure.

[0101] Referring now to FIGS. **18A**, **18B**, **18C** and **18D**, mapping electrodes **22**, RF electrodes **88** and/or apertures **64** may be distributed in a variety of patterns along expandable mapping assembly **20** or basket assembly **50** to facilitate mapping and in order to produce a desired placement and pattern of lesions **14**. Typical electrode (both mapping and RF varieties) and aperture distribution patterns include, but are not limited to, a radial distribution **104** (refer to FIG. **18A**), a longitudinal distribution **105** (refer to FIG. **18B**), a spiral distribution **106** (refer to FIG. **18C**) and a combination of

longitudinal and radial distributions **107** (refer to FIG. **18D**). It will be appreciated that other combinations, patterns and geometries for electrode and aperture placement, may also be suitable. These electrodes may be cooled as described hereafter.

[0102] FIG. **19** is a flow chart illustrating one embodiment of the procedure for using sphincter mapping and treatment apparatus **10**. In this embodiment, sphincter mapping and treatment apparatus **10** is first introduced into the esophagus under local anesthesia. Sphincter mapping and treatment apparatus **10** can be introduced into the esophagus by itself or through a lumen in an endoscope (not shown), such as disclosed in U.S. Pat. Nos. 5,448,990 and 5,275,608, incorporated herein by reference, or similar esophageal access devices known to those skilled in the art. Basket assembly **50** is expanded as described herein. This serves to temporarily dilate the LES or sufficiently to efface a portion of or all of the folds of the LES. In an alternative embodiment, esophageal dilation and subsequent LES fold effacement can be accomplished by insufflation of the esophagus (a known technique) using gas introduced into the esophagus through shaft lumen **36**, or an endoscope or similar esophageal access device as described above. Once treatment is completed, basket assembly **50** is returned to its predeployed or contracted state and sphincter mapping and treatment apparatus **10** is withdrawn from the esophagus. This results in the LES returning to approximately its pretreatment state and diameter. It will be appreciated that the above procedure is applicable in whole or part to the treatment of other sphincters in the body.

[0103] As discussed previously, controller **24** and electro-potential map **27** are used by the physician to diagnose abnormalities and pathologies within sphincter **16** and adjoining structures. More specifically, they are used to identify gastric electrical signals **17** and electrical events that include depolarization, contraction and repolarization. Referring now to FIG. **20**, this information is used by the physician to determine target treatment sites **12** in the LES or adjoining anatomical structures that are acting as electrical foci **108** or electrically conductive pathways **109** for aberrant electrical signals **111** causing abnormal or otherwise inappropriate relaxation of the smooth muscle of the LES or other sphincter **16**. These targeted treatment sites **12** are then treated as described herein so as to create lesions **14** which disrupt, block or otherwise prevent the generation and transmission of sufficient aberrant electrical signals **111** to cause relaxation of the LES or other sphincter wall **26**.

[0104] A variety of other diagnostic methods can be employed as an adjunct to surface mapping of sphincter wall **26**. These methods include, but are not limited to, the following: (i) visualization of the interior surface of the esophagus via an endoscope or other viewing apparatus inserted into the esophagus, (ii) visualization of the interior morphology of the esophageal wall using ultrasonography to establish a baseline for the tissue to be treated; and, (iii) impedance measurement to determine the electrical conductivity between the esophageal mucosal layers and sphincter mapping and treatment apparatus **10**.

[0105] In one embodiment of the invention, impedance measurement is used as a tool to locate the position of the nerve during either the diagnostic or treatment phases of the procedure. In these and related embodiments, the physician uses an impedance sensor **140** (described herein) positioned on one of electrodes **22**, **88** and **90** or mapping assembly **20** to locate the position of the nerve **8** to be ablated, and/or used as

a conductive pathway for the delivery of energy to a selected gastric treatment site **12**. Specifically, nerve **8**, **8'** is located by a decrease in measured tissue impedance relative to a non-nerve portion of tissue. During or after the delivery of energy to nerve **8**, **8'** the ablation of the selected nerve can be monitored, quantified or treated through the use of tissue impedance measurement.

[0106] In related embodiments, a similar technique can be used to locate a vagus nerve **8''** or other nerve **8**, **8'**, **8''** that is desired to be protected during the treatment phase of the procedure. Further, during the delivery of energy to the treatment site **12**, sensor **140** can be positioned at or adjacent the nerve to be protected to monitor nerve impedance levels during the treatment of energy. Sensor **140** is coupled to a control system described herein. If the impedance level at or near nerve **8** exceeds a predetermined value, the delivery of energy to electrode **88** or **90** is shut off or decreased by the control system for the position.

[0107] In the treatment phase of the procedure, the delivery of energy to treatment site **12** can be conducted under feedback control, manually or by a combination of both. Feedback control (described herein) enables sphincter mapping and treatment apparatus **10** to be positioned and retained in the esophagus during treatment with minimal attention by the physician. RF electrodes **88** can be multiplexed in order to treat the entire targeted treatment site **12** or only a portion thereof. Feedback can be included and is achieved by the use of one or more of the following methods: (i) visualization, (ii) impedance measurement, (iii) ultrasonography, (iv) temperature measurement; and, (v) sphincter contractile force measurement via manometry. The feedback mechanism permits the selected on-off switching of different RF electrodes **88** in a desired pattern, which can be sequential from one electrode **88** to an adjacent electrode **88**, or can jump around between non-adjacent RF electrodes **88**. Individual RF electrodes **88** are multiplexed and volumetrically controlled by controller **24**.

[0108] The area and magnitude of cell injury in the LES or sphincter **16** can vary. However, it is desirable to deliver sufficient energy to the targeted treatment site **12** to be able to achieve tissue temperatures in the range of 55-95° C. and produce lesions **14** at depths ranging from 1-4 mm from the interior surface of the LES or sphincter wall **26**. Typical energies delivered to the esophageal wall include, but are not limited to, a range between 100 and 50,000 joules per electrode **88**. It is also desirable to deliver sufficient energy such that the resulting lesions **14** have a sufficient magnitude and area of cell injury to cause an infiltration of lesion **14** by fibroblasts **110**, myofibroblasts **112**, macrophages **114** and other cells involved in the tissue healing process (refer to FIG. **21**). As shown in FIG. **22**, these cells cause a contraction of tissue around lesion **14**, decreasing its volume and/or altering the biomechanical properties at lesion **14** so as to result in a tightening of LES or sphincter **16**. These changes are reflected in transformed lesion **14'** shown in FIG. **19B**. The diameter of lesions **14** can vary between 0.1 to 4 mm. It is preferable that lesions **14** are less than 4 mm in diameter in order to reduce the risk of thermal damage to the mucosal layer. In one embodiment, a 2 mm diameter lesion **14** centered in the wall of the smooth muscle provides a 1 mm buffer zone to prevent damage to the mucosa, submucosa and adventitia, while still allowing for cell infiltration and subsequent sphincter tightening on approximately 50% of the thickness of the wall of the smooth muscle (refer to FIG. **23**).

[0109] From a diagnostic standpoint, it is desirable to image the interior surface and wall of the LES or other sphincter 16, including the size and position of created lesions 14. It is desirable to create a map of these structures which can be inputted to controller 24 and used to direct the delivery of energy to treatment site 12. Referring to FIG. 24, this can be accomplished through the use of ultrasonography (a known procedure) which involves the use of an ultrasound power source 116 coupled to one or more ultrasound transducers 118 that are positioned on expandable mapping assembly 20 or basket assembly 50. An output is associated with ultrasound power source 116.

[0110] Each ultrasound transducer 118 can include a piezoelectric crystal 120 mounted on a backing material 122 that is in turn, attached to expandable mapping assembly 20 or basket assembly 50. An ultrasound lens 124, fabricated on an electrically insulating material 126, is mounted over piezoelectric crystal 120. Piezoelectric crystal 120 is connected by electrical leads 128 to ultrasound power source 116. Each ultrasound transducer 118 transmits ultrasound energy into adjacent tissue. Ultrasound transducers 118 can be in the form of an imaging probe such as Model 21362, manufactured and sold by Hewlett Packard Company, Palo Alto, Calif. In one embodiment, two ultrasound transducers 118 are positioned on opposite sides of expandable mapping assembly 20 or basket assembly 50 to create an image depicting the size and position of lesion 14 in selected sphincter 16.

[0111] It is desirable that lesions 14 are predominantly located in the smooth muscle layer of selected sphincter 16 at the depths ranging from 1 to 4 mm from the interior surface of sphincter wall 26. However, lesions 14 can vary both in number and position within sphincter wall 26. It may be desirable to produce a pattern of multiple lesions 14 within the sphincter smooth muscle tissue in order to obtain a selected degree of tightening of the LES or other sphincter 16. Typical lesion patterns shown in FIGS. 25A-D include, but are not limited to, (i) a concentric circle of lesions 14 all at fixed depth in the smooth muscle layer evenly spaced along the radial axis of sphincter 16, (ii) a wavy or folded circle of lesions 14 at varying depths in the smooth muscle layer evenly spaced along the radial axis of sphincter 16, (iii) lesions 14 randomly distributed at varying depths in the smooth muscle, but evenly spaced in a radial direction; and, (iv) an eccentric pattern of lesions 14 in one or more radial locations in the smooth muscle wall. Accordingly, the depth of RF and thermal energy penetration sphincter 16 is controlled and selectable. The selective application of energy to sphincter 16 may be the even penetration of RF energy to the entire targeted treatment site 12, a portion of it, or applying different amounts of RF energy to different sites depending on the condition of sphincter 16. If desired, the area of cell injury can be substantially the same for every treatment event.

[0112] In other embodiments shown in FIGS. 25 E-G, lesions 14 are configured to produce an area of electrical block 19 (also called blockage area 19 or area 19) to a myoelectric or gastric signal 17, particularly a signal such as a gastric arrhythmia 17' causing a TLSER. The area of electrical block is achieved by delivering sufficient energy to make the tissue comprising all or a portion of areas 19 nonconducting. This can be accomplished by heating the tissue sufficiently to denature proteins, destroy cell membrane, dehydrate/desiccate the tissue or otherwise altering its physical properties. Blockage area 19 can also be achieved by deliv-

ering sufficient energy to damage, or destroy a nerve pathway within area 19 or a mechanical or chemo receptor 9, 9'.

[0113] In various embodiments, blockage area 19 can be placed by the physician in a number of locations including the cardia, fundus, angle of His, LES and esophagus. The placement of area 19 in the cardia can include positioning lesions 14 and blockage area 19 in or along a nerve pathway within the cardia or fundus. In still another related embodiment, area 19 comprises a lesion 14 placed within or along an afferent nerve 8' leading from a mechano or chemo receptor in the cardia or fundus to another area of the cardia, or LES (see FIG. 25 F). In one preferred embodiment area 19 is placed within the cardia and blocks gastric signals 17 from the fundus or cardia to the LES including signals 17 from a mechano receptor or chemo receptor in the cardia or fundus to the cardia or LES (see FIG. 25 G). Shapes for area 19 include but are not limited to substantial linear, rectangular, circular, semicircular, annular, semi-annular and combinations thereof. In specific embodiments, area 19 can comprise a linear or partially annular shape positioned in the cardia (see FIG. 25G).

[0114] Referring to FIG. 26, it may be desirable to cool all or a portion of the area near the electrode-tissue interface 130 before, during or after the delivery of energy in order to reduce the degree and area of cell injury. Specifically, the use of cooling preserves the mucosal layers of sphincter wall 26 and protects, or otherwise reduces the degree of cell damage to cooled zone 132 in the vicinity of lesion 14. In one embodiment the use of cooling is used to protect and/or minimize damage to a vagus nerve or other nerve 8" associated with a swallowing reflex. Referring now to FIG. 27, this can be accomplished through the use of a cooling solution 70 that is delivered by apertures 64 which is in fluid communication with shaft lumen 36 that is, in turn, in fluid communication with fluid reservoir 134 and a control unit 136, whose operation is described herein, that controls the delivery of the fluid.

[0115] Similarly, it may also be desirable to cool all or a portion of the electrode 88. The rapid delivery of heat through electrode 88, may result in the build up of charred biological matter on electrode 88 (from contact with tissue and fluids e.g., blood) that impedes the flow of both thermal and electrical energy from electrode 88 to adjacent tissue and causes an electrical impedance rise beyond a cutoff value set on RF power source 56. A similar situation may result from the desiccation of tissue adjacent to electrode 88. Cooling of the electrode 88 can be accomplished by cooling solution 70 that is delivered by apertures 64 as described previously. Referring now to FIG. 28, electrode 88 may also be cooled via a fluid channel 138 in electrode 88 that is in fluid communication with fluid reservoir 134 and control unit 136.

[0116] As shown in FIG. 29, one or more sensors 140 may be positioned adjacent to or on electrode 88 for sensing the temperature of sphincter tissue at treatment site 12. More specifically, sensors 140 permit accurate determination of the surface temperature of sphincter wall 26 at electrode-tissue interface 130. This information can be used to regulate both the delivery of energy and cooling solution 70 to the interior surface of sphincter wall 26. In various embodiments, sensors 140 can be positioned at any position on expandable mapping assembly 20 or basket assembly 50. Suitable sensors that may be used for sensor 140 include: thermocouples, fiber optics, resistive wires, thermocouple IR detectors, and the like. Suit-

able thermocouples for sensor **140** include: T type with copper constantene, J type, E type and K types as are well known those skilled in the art.

[0117] Temperature data from sensors **140** are fed back to control unit **136** and through an algorithm which is stored within a microprocessor memory of control unit **136**. Instructions are sent to an electronically controlled micropump (not shown) to deliver fluid through the fluid lines at the appropriate flow rate and duration to provide control temperature at the electrode-tissue interface **130** (refer to FIG. 27).

[0118] The reservoir of control unit **136** may have the ability to control the temperature of the cooling solution **70** by either cooling the fluid or heating the fluid. Alternatively, a fluid reservoir **134** of sufficient size may be used in which the cooling solution **70** is introduced at a temperature at or near that of the normal body temperature. Using a thermally insulated reservoir **142**, adequate control of the tissue temperature may be accomplished without need of refrigeration or heating of the cooling solution **70**. The flow of cooling solution **70** is controlled by control unit **136** or another feedback control system (described herein) to provide temperature control at the electrode-tissue interface **130**.

[0119] A second diagnostic phase may be included after the treatment is completed. This provides an indication of LES tightening treatment success, and whether or not a second phase of treatment, to all or only a portion of the esophagus, now or at some later time, should be conducted. The second diagnostic phase is accomplished through one or more of the following methods: (i) visualization, (ii) measuring the impedance, (iii) ultrasonography, (iv) temperature measurement, (v) measurement of LES tension and contractile force via manometry or (vi) mapping/measuring the frequency of gastric myoelectric activity including normal slow frequency waves, and gastric arrhythmias **17'** including tachygastrias and bradygastrias. In the latter case, the clinician can use the quantitative analysis of gastric arrhythmias (e.g. frequency, signal amplitude) **17'** as both an indication of a TLSER and as means to titrate treatment and establish a clinical endpoint particularly in the case when doing gastric nerve ablation or creating areas of electrical block to pathways causing a TLSER. The detection and analysis of gastric arrhythmias **17'** can be made using signal processing means described herein. The second diagnostic phase can also include stimulation to evoke a swallowing reflex using a stimulation device/means described herein to assure that the swallowing reflex and associated nerves are still functional.

[0120] In one embodiment, sphincter mapping and treatment apparatus **10** is coupled to an open or closed loop feedback system. Referring now to FIG. 30, an open or closed loop feedback system couples sensor **346** to energy/power source **392**. In this embodiment, electrode **314** is one or more RF electrodes **314** and power source **392** is an RF generator.

[0121] The temperature of the tissue, or of RF electrode **314**, is monitored, and the output power of energy source **392** adjusted accordingly. The physician can, if desired, override the closed or open loop system. A microprocessor **394** (also called controller **394** which can be the same as controller **24**) can be included and incorporated in the closed or open loop system to switch power on and off, as well as modulate the power. The closed loop system utilizes microprocessor **394** to serve as a controller to monitor the temperature, adjust the RF power, analyze the result, refeed the result, and then modulate the power. More specifically, controller **394** governs the power levels, cycles, and duration that the radio frequency

energy is distributed to the individual electrodes **314** to achieve and maintain power levels appropriate to achieve the desired treatment objectives and clinical endpoints. Controller **394** can also in tandem, govern the delivery of cooling fluid and, if desired, the removal of aspirated material. Microprocessor **394** can be integral to or otherwise coupled to power source **392**. The controller **394** can include an input/output (I/O) device **394'**. The I/O device **394'** allows the physician to input control and processing variables, to enable the controller to generate appropriate command signals. The I/O device **394'** also receives real time processing feedback information from one or more sensors associated with the operative element (as will be described later), for processing by the controller **394**, e.g., to govern the application of energy and the delivery of processing fluid. The I/O device **394'** may also include a user interface or graphical user interface (GUI), to graphically present processing information to the physician for viewing or analysis. As discussed herein, controller **394** can also be coupled to a fluid delivery apparatus and/or an aspirating apparatus.

[0122] With the use of sensor **346** and the feedback control system a tissue adjacent to RF electrode **314** can be maintained at a desired temperature for a selected period of time without causing a shut down of the power circuit to electrode **314** due to the development of excessive electrical impedance at electrode **314** or adjacent tissue as is discussed herein. Each RF electrode **314** is connected to resources which generate an independent output. The output maintains a selected energy at RF electrode **314** for a selected length of time.

[0123] Current delivered through RF electrode **314** is measured by current sensor **396**. Voltage is measured by voltage sensor **398**. Impedance and power are then calculated at power and impedance calculation device **400**. These values can then be displayed at user interface and display **402**. Signals representative of power and impedance values are received by a controller **404**.

[0124] A control signal is generated by controller **404** that is proportional to the difference between an actual measured value, and a desired value. The control signal is used by power circuits **406** to adjust the power output in an appropriate amount in order to maintain the desired power delivered at respective RF electrodes **314**.

[0125] In a similar manner, temperatures detected at sensor **346** provide feedback for maintaining a selected power. Temperature at sensor **346** is used as a safety means to interrupt the delivery of energy when maximum pre-set temperatures are exceeded. The actual temperatures are measured at temperature measurement device **408**, and the temperatures are displayed at user interface and display **402**. A control signal is generated by controller **404** that is proportional to the difference between an actual measured temperature and a desired temperature. The control signal is used by power circuits **406** to adjust the power output in an appropriate amount in order to maintain the desired temperature delivered at the sensor **346**. A multiplexer can be included to measure current, voltage and temperature, at the sensor **346**, and energy can be delivered to RF electrode **314** in monopolar or bipolar fashion.

[0126] Controller **404** can be a digital or analog controller, or a computer with software. When controller **404** is a computer it can include a CPU coupled through a system bus. This system can include a keyboard, a disk drive, or other non-

volatile memory systems, a display, and other peripherals, as are known in the art. Also coupled to the bus is a program memory and a data memory.

[0127] User interface and display 402 includes operator controls and a display and may include a GUI interface as discussed herein. Controller 404 can be coupled to imaging systems including, but not limited to, ultrasound, CT scanners, X-ray, NM, mammographic X-ray and the like. Further, direct visualization and tactile imaging can be utilized.

[0128] The output of current sensor 396 and voltage sensor 398 are used by controller 404 to maintain a selected power level at RF electrode 314. The amount of RF energy delivered controls the amount of power. A profile of the power delivered to electrode 314 can be incorporated in controller 404 and a preset amount of energy to be delivered may also be profiled.

[0129] Circuitry, software and feedback to controller 404 result in process control, the maintenance of the selected power setting which is independent of changes in voltage or current, and is used to change the following process variables: (i) the selected power setting, (ii) the duty cycle (e.g., on-off time), (iii) bipolar or monopolar energy delivery; and, (iv) fluid delivery, including flow rate and pressure. These process variables are controlled and varied, while maintaining the desired delivery of power independent of changes in voltage or current, based on temperatures monitored at sensor 346.

[0130] Referring now to FIG. 31, current sensor 396 and voltage sensor 398 are connected to the input of an analog amplifier 410. Analog amplifier 410 can be a conventional differential amplifier circuit for use with sensor 346. The output of analog amplifier 410 is sequentially connected by an analog multiplexer 412 to the input of A/D converter 414. The output of analog amplifier 410 is a voltage which represents the respective sensed temperatures. Digitized amplifier output voltages are supplied by A/D converter 414 to microprocessor 394. Microprocessor 394 may be a type 68HCII available from Motorola. However, it will be appreciated that any suitable microprocessor or general purpose digital or analog computer can be used to calculate impedance or temperature.

[0131] Microprocessor 394 sequentially receives and stores digital representations of impedance and temperature. Each digital value received by microprocessor 394 corresponds to different temperatures and impedances. Calculated power and impedance values can be indicated on user interface and display 402. Alternatively, or in addition to the numerical indication of power or impedance, calculated impedance and power values can be compared by microprocessor 394 to power and impedance limits. When the values exceed predetermined power or impedance values, a warning can be given on user interface and display 402, and additionally, the delivery of RF energy can be reduced, modified or interrupted. A control signal from microprocessor 394 can modify the power level supplied by energy source 392.

[0132] FIG. 32 illustrates a block diagram of a temperature and impedance feedback system that can be used to control the delivery of energy to tissue site 416 by energy source 392 and the delivery of cooling solution 70 to electrode 314 and/or tissue site 416 by flow regulator 418. Energy is delivered to RF electrode 314 by energy source 392, and applied to tissue site 416. A monitor 420 ascertains tissue impedance, based on the energy delivered to tissue, and compares the measured impedance value to a set value. If the measured impedance exceeds the set value, a disabling signal 422 is transmitted to energy source 392, ceasing further delivery of energy to RF

electrode 314. If the measured impedance is within acceptable limits, energy continues to be applied to the tissue.

[0133] The control of cooling solution 70 to electrode 314 and/or tissue site 416 is done in the following manner. During the application of energy, temperature measurement device 408 measures the temperature of tissue site 416 and/or RF electrode 314. A comparator 424 receives a signal representative of the measured temperature and compares this value to a pre-set signal representative of the desired temperature. If the tissue temperature is too high, comparator 424 sends a signal to a flow regulator 418 (connected to an electronically controlled micropump, not shown) representing a need for an increased cooling solution flow rate. If the measured temperature has not exceeded the desired temperature, comparator 424 sends a signal to flow regulator 418 to maintain the cooling solution flow rate at its existing level.

[0134] This specification discloses various catheter-based systems and methods for treating dysfunction of sphincters and adjoining tissue regions in the body. The systems and methods are particularly well suited for treating these dysfunctions in the upper gastrointestinal tract, e.g., in the lower esophageal sphincter and adjacent structures of the stomach such as the cardia. The disclosed systems and methods are also applicable for use in treating other dysfunctions elsewhere in the body, which are not necessarily sphincter-related. For example, the various aspects of the invention have application in procedures requiring treatment of hemorrhoids, or incontinence, or restoring compliance to or otherwise tightening interior tissue or muscle regions. The systems and methods that embody features of the invention are also adaptable for use with systems and surgical techniques that are not necessarily catheter-based. Furthermore, this specification is not intended to be exhaustive or to limit the invention to the precise forms disclosed. Obviously, many modifications and variations will be apparent to practitioners skilled in this art.

[0135] In another embodiment shown in FIG. 33, apparatus 10 can be coupled to a signal processing system 500 which comprises a signal processor 501 that is integral to or otherwise coupled to a controller 504. Signal processing means 501 in turn can be coupled to data/signal storage device 510 (also called memory resources 510) and signal comparator means 520. Signal processor 501 is configured to take time domain bioelectric signals/waveforms 517 detected by electrodes 514, (such as myoelectric or gastric signals 17 including those corresponding to or otherwise indicative of a TLERS) and convert them into frequency domain signal 517' in order to obtain information which can be displayed as a waveform indicative of the frequency of TLERS or other myo/neuro gastric event, such as a peristaltic wave, stomach contraction, swallowing reflex. The output signal 517' of signal processor 501 can be coupled to and/or displayed on user interface 402. Signal processor 501 can also be used to calculate other wave related functions such as power spectral density and the like. Controller 504 serves to control the data exchange/handshake (both analog and digital) between signal processor 504, comparators 520, and data storage device 510. Signal processor 501 or controller 504 can output signal 517' in either digital or analog form. In various embodiments controller 504 can be a microprocessor or application integrated circuit (ASIC) which can include but is not limited to having integral: processors, data bus, ROM, A/D converters, video processor, math processor, and input/output channels. In related embodiments, signal processing means 501 can be

one or more microprocessors or integrated circuits **502** with electronically stored or embedded instructions sets or programs **503** for performing a mathematical transform (including a fourier or fast fourier transform (including a discrete FFT) or other wavelet transform function known in the art) to convert a time domain signal **517** (which can also be gastric signal **17**) to a frequency domain signal **517'**, or vice versa. Processor **501** can also include but is not limited to having an integral data bus, ROM, A/D converter, video processor, math processor and input/output channels. In various embodiments, signal processor **501** or controller **504** can be a commercially available spectrum analyzer such as that made by the Hewlett Packard Corporation or a commercially available microprocessor such as an Intel® Pentium® or Pentium III® series, or a Motorola® Power PCs series microprocessor. Processor **501** can be coupled to or have integral memory resources **505** which can be a Read Only Memory (ROM) chip containing stored or otherwise embedded programming for performing various signal processing functions including but not limited to fourier transforms, wavelet functions, filtering (e.g. high and low pass filtering) and signal averaging and the like.

[0136] In a related embodiment shown in FIG. **34**, a signal stimulation means **530** can be coupled to signal processor **501**. Signal stimulation means **530** generates a selectable electrical signal/output **535** sufficient to produce a TLESR, swallowing reflex, peristaltic wave or related myo/neuro esophageal or gastric event. Additionally signal stimulation means **530** can be configured to produce any number of evoked potentials or motor evoked potentials known in the art. In various embodiments, signal stimulation means **530** can be a commercially available medical electrical power supply such as DC or AC power supply available from the Hewlett Packard® Corporation, or a nerve stimulating device available from Danmeter A/S (Odense, Denmark) such as the Elfameter or one of the Neuro-Diagnostic product line available from the Medtronic® Corporation (Minneapolis, Minn.). A stimulating electrode **522** is electrically coupled to stimulation means **530** and can be the same as mapping electrode **22** or treatment electrode **22**. In another embodiment, stimulating electrode **522** can be a transdermal electrode **523** placed on the abdomen epidermal layer overlying the LES or nearby. In this embodiment signal stimulation means **530** can be configured for producing a transdermal stimulating signal of sufficient amplitude and frequency for producing TLESR transdermally. Stimulation means **530** can be coupled to user interface **402** which can have user selected switching capability between in vivo and transdermal stimulation configurations. In various embodiments one electrode **522** can both be a mapping and receive electrode coupled to stimulation means **530** and signal comparator means **520** (in this case signal stimulation means includes a time gating capability/algorithm for alternatively putting electrode **522** in a stimulating/transmitting mode and a mapping receiving mode. For embodiments with multiple electrodes **522**, electrodes **522** can be multiplexed such that a portion are configured for stimulation and another portion are configured for mapping. For transdermal stimulation embodiments, electrode **522** on the apparatus **10** can be used as the receiving electrode or a separate transdermally coupled electrode **523** (coupled to signal processing means **501**) can be employed. In one embodiment, transdermal receiving electrode **523** can be a plurality of electrodes **523'** placed in a larger area on the abdomen. The use of a plurality of electrodes improves signal

detection, sensitivity and acquisition capability of signal processing means **501** for TLESR and other aberrant gastric signals. For transdermal embodiments, transdermal mapping and receiving electrodes **522** and **523** can be silver-silver chloride transdermal electrodes well known in the medical electronics art. In one transdermal embodiment, one or both of transdermal electrodes **523** and signal processing means **501** can be components from the Digitrapper™ EGG System available from the Medtronic® Corporation (Minneapolis, Minn.).

[0137] In one embodiment depicted in FIG. **35**, signal stimulation means **530** and signal processing means **501** are configured, to induce and/or monitor the presence of the swallowing reflex before, during or after the delivery of energy to the treatment site **12**. This and related embodiments allow for the protection of a vagus **8''** or other nerve **8, 8', 8''** involved or associated in the swallowing reflex.

[0138] To facilitate such stimulation the stimulating electrode **522** can be positioned on catheter **18** so as to be located in the more proximal/upper portions **6'** of the esophagus **6** including the pharynx and oral cavity. In one embodiment, stimulating electrode **522** can be positioned proximal to mapping or treatment electrode **22**. This allows for simultaneous stimulation of the upper esophagus **6'** to produce a swallowing reflex or other myo-gastric event (e.g. peristaltic wave) while one or more of the following are performed: i) observation (by endoscopic, visual or other means) in the esophagus or LES for the swallowing reflex and/or opening of the LES, ii) mapping/sensing of the swallowing reflex, TLESR or other myo-gastric event and iii) delivery of energy to treatment site **12** in the LES **6** or other upper GI site. In other embodiments, stimulating electrode **522** can be positioned anywhere along the length of catheter **18** including basket assembly **20**. In these and relate embodiments, the signal stimulating electrode **522** can be used to evoke a swallowing reflex before or during the delivery of treatment to assure the integrity of swallowing reflex and related nerves and then subsequently afterward treatment to assure the same.

[0139] The foregoing description of a preferred embodiment of the invention has been presented for purposes of illustration and description. It is not intended to be exhaustive or to limit the invention to the precise forms disclosed. Obviously, many modifications and variations will be apparent to practitioners skilled in this art. It is intended that the scope of the invention be defined by the following claims and their equivalents.

1-3. (canceled)

4. A system for regulating temperature at a tissue site during treatment of gastroesophageal reflux disease, the system comprising:

a device having a plurality of electrodes, a tissue temperature measuring device attached to the electrodes for producing a signal representative of a measured tissue temperature at an interface between the electrodes and tissue, the electrodes advanceable from a retracted position within the device to an extended position extending from the device to apply energy to the lower esophageal sphincter to form lesions to tighten the sphincter to treat gastroesophageal reflux disease;

a power source to apply energy to the plurality of electrodes, the power source having multiple channels to deliver separately modulated power to the plurality of electrodes such that individual electrodes of the plurality of electrodes generate an independent output, the tissue

temperature measuring device coupled to the power source, and power supplied is modified in response to tissue temperature measurement;

a tissue impedance monitor, the tissue impedance monitor measuring tissue impedance based on energy delivered to tissue, the measured impedance compared to a preset value and if the measured impedance exceeds the preset value a disabling signal is generated to cease delivery of energy;

an electronically controlled pump for delivering fluid at an appropriate flow rate and duration to control temperature at the interface between the electrodes and tissue; and

a comparator receiving the signal representative of the measured tissue temperature and comparing the measured tissue temperature value to a pre-set desired tissue temperature, if the measured tissue temperature exceeds such pre-set desired tissue temperature, a signal is sent to a flow regulator electronically connected to a fluid pump to increase flow of cooling solution to the tissue, and the existing flow rate of cooling solution to the tissue site is maintained if the measured tissue temperature does not exceed the desired temperature.

5. The system of claim 4, wherein the device includes a basket assembly and the electrodes are deployed by expansion of the basket assembly.

6. The system of claim 4, wherein the device includes a basket assembly comprising a plurality of arms, the arms having an aperture and the electrodes advanceable through the apertures in the arms.

7. The system of claim 6, wherein the apertures are structured to limit the depth of penetration of the electrodes.

8. The system of claim 4, further comprising a basket assembly and a pull wire to expand the basket assembly.

9. The system of claim 4, wherein when the electrodes are moved to the extended position the temperature measuring device is located further radially from a longitudinal axis of the device.

10. The system of claim 4, further comprising a basket assembly and an inflatable balloon to expand the basket assembly.

11. The system of claim 4, wherein the device is configured for insertion through a mouth of a patient.

12. The system of claim 1, wherein increasing and maintaining existing flow rate of cooling solution maintains the tissue at a desired temperature for a selected period of time.

13. A system for regulating temperature at a tissue site during treatment of gastroesophageal reflux disease, the system comprising:

a device having a basket assembly at a distal portion and a plurality of electrodes, the basket assembly having a plurality of arms and expandable to an expanded configuration, the arms having an aperture for passage of an

electrode of the plurality of electrodes, a tissue temperature measuring device attached to the electrodes for producing a signal representative of a measured tissue temperature at the interface between the electrodes and tissue, the electrodes advanceable from a retracted position within the device to an extended position extending from the apertures in the arms of the basket assembly to apply energy to the lower esophageal sphincter to form lesions to tighten the sphincter to treat gastroesophageal reflux disease, the tissue temperature measuring device movable with advancement of the electrodes;

a power source to apply energy to the plurality of electrodes, the power source having multiple channels to deliver separately modulated power to each of the plurality of electrodes such that each of the plurality of electrodes generates an independent output;

a feedback system coupling the tissue temperature measuring device to the power source, the power supplied responsive to tissue temperature measurement to regulate delivery of energy in response to tissue temperature;

an electronically controlled pump for delivering fluid at an appropriate flow rate and duration to control temperature at the interface between the electrodes and tissue; and

a comparator receiving the signal representative of the measured tissue temperature and comparing the measured temperature value to a pre-set desired tissue temperature, if the measured tissue temperature exceeds such pre-set desired tissue temperature, a signal is sent to a flow regulator electronically connected to a fluid pump to increase flow of cooling solution to the tissue, and the existing flow rate of the cooling solution to the tissue site is maintained if the measured tissue temperature does not exceed the desired temperature.

14. The system of claim 13, further comprising a tissue impedance monitor, the tissue impedance monitor measuring tissue impedance based on energy delivered to tissue, the measured impedance compared to a preset value and if the measured impedance exceeds a preset value a disabling signal is generated to cease delivery of energy.

15. The system of claim 13, wherein the electrodes in the advanced position curve radially outwardly away from a longitudinal axis of the device.

16. The system of claim 14, wherein the electrodes in the advanced position curve radially outwardly away from a longitudinal axis of the device.

17. The system of claim 13, further comprising an inflatable balloon to expand the basket assembly.

18. The system of claim 13, wherein the electrodes have penetrating tips.

19. The system of claim 13, further comprising a user interface to display the measured tissue temperature.

* * * * *