

(Model.)

2 Sheets—Sheet 1.

E. BRÜNCKER.
SEWING MACHINE.

No. 400,744.

Patented Apr. 2, 1889.

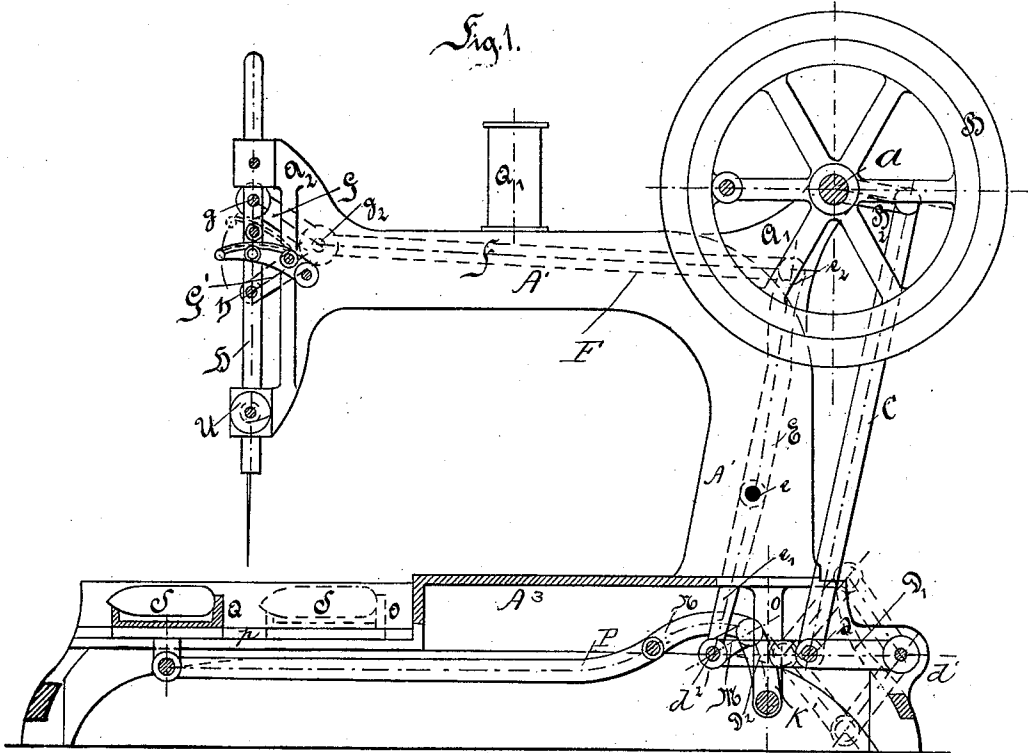
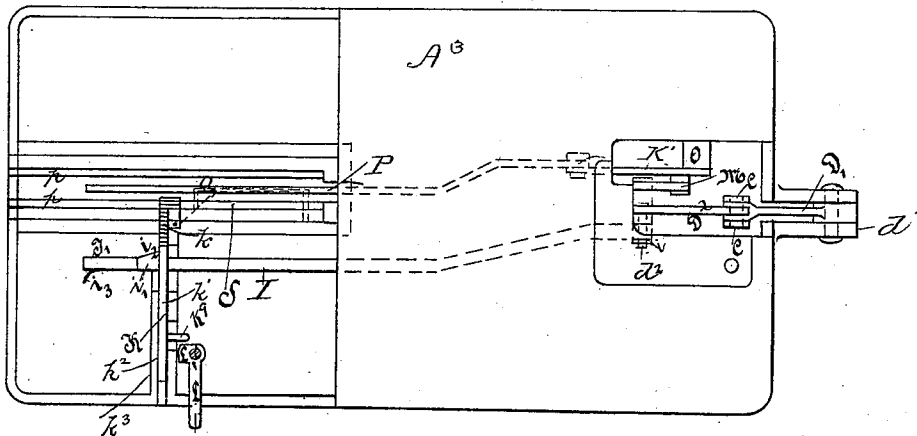

Fig. 2.



Witnesses.
Leonard
Henry Threlkett

Inventor
Ewald Brüncker.
Counolly Prop

(Model.)

2 Sheets—Sheet 2.

E. BRÜNCKER.
SEWING MACHINE.

No. 400,744.

Patented Apr. 2, 1889.

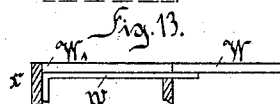
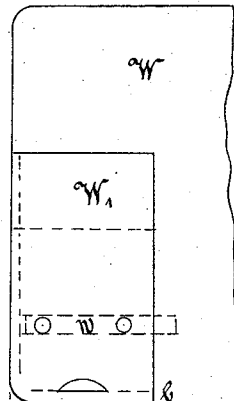
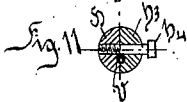
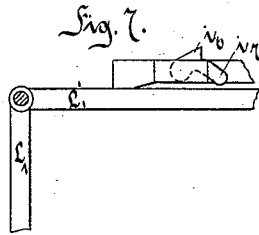
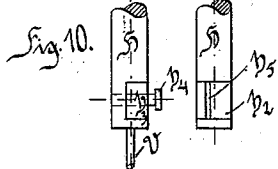
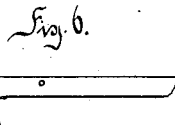
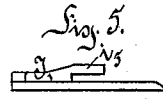
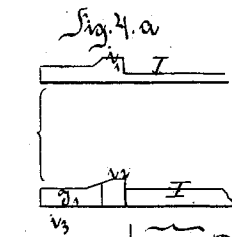
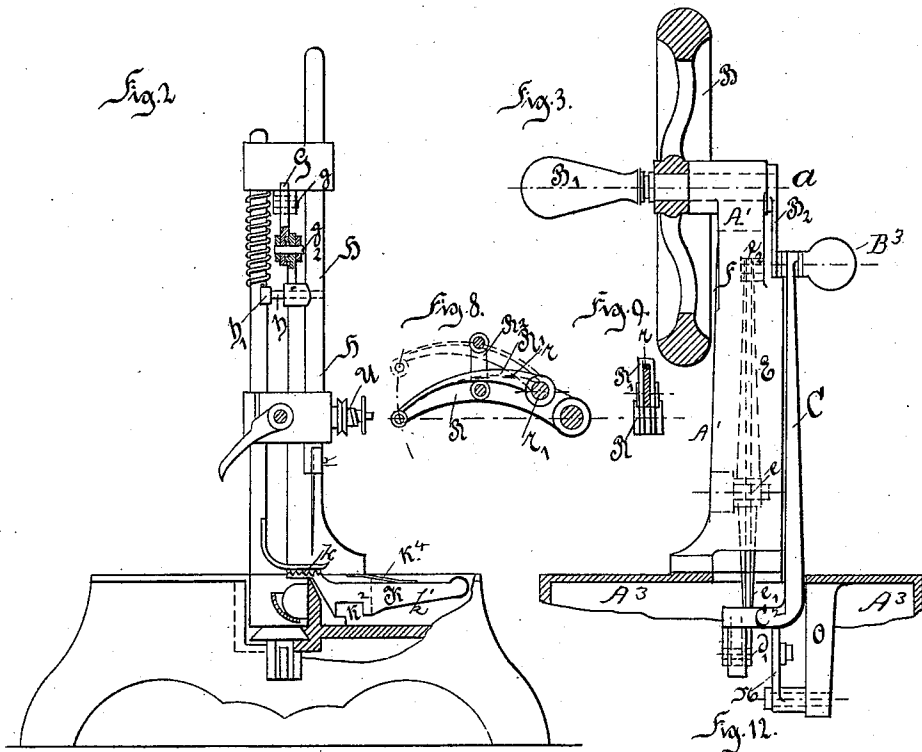

Witnesses
Leonard
Henny Cherrish

Inventor.
Ewald Brüncker
Conolly Bros attys

UNITED STATES PATENT OFFICE,

EWALD BRÜNCKER, OF SIEGLAR, NEAR TROISDORF, GERMANY.

SEWING-MACHINE.

SPECIFICATION forming part of Letters Patent No. 400,744, dated April 2, 1889.

Application filed March 9, 1886. Serial No. 194,613. (Model.) Patented in Germany September 30, 1885, No. 47,993, and in England December 18, 1885, No. 15,569.

To all whom it may concern:

Be it known that I, EWALD BRÜNCKER, civil engineer, a subject of the Emperor of Germany, residing at Sieglar, near Troisdorf, in the Empire of Germany, have invented Improvements in Sewing-Machines, (for which I have applied for Letters Patent in the German Empire, dated September 30, 1885, No. 47,993, and in Great Britain, No. 15,569, dated the 18th day of December, 1885,) of which the following is a specification.

This invention has relation to sewing-machines, and has for its object the provision of novel means for imparting movement from the main shaft to the shuttle, feed-bar, and other portions of the machine without the intervention of gearing, belts, or eccentrics.

My invention has also for its object the provision of means for imparting motion to the stitch-forming and cloth-feeding devices, whereby the main shaft may be rotated in either direction without interfering with the proper operation of the machine.

My invention consists in the novel construction and combination hereinafter described and specifically claimed.

In the accompanying drawings, Figure 1 is a vertical longitudinal section of a sewing-machine embodying my invention. Fig. 2 is a vertical transverse section of the same, taken in front of the needle-head. Fig. 3 is a vertical transverse section through the hand-wheel on the operating-shaft and through the bed in the rear of the needle-arm standard. Fig. 4 is a plan view of the machine with needle-arm removed. Figs. 4^a, 5, 6, 7, 8, 9, 10, 11, 12, and 13 are detached views of details.

A³ designates the bed of the machine, upon which is mounted the usual needle-arm, A', having the head a², in which move the needle-rod and presser-bar.

a designates the power-shaft, adapted either for hand-operated or treadle machines. This shaft is journaled in the upper part of the needle-arm and carries the fly wheel or pulley B on one end and upon the other the crank-arm B², to which may be attached the handle B³, if the machine is to be operated by hand.

To the end of the crank-arm B² is pivotally connected a bar or connecting-rod, C, which

extends downwardly, and at its lower end is bent laterally and forked, as shown at C².

The arms or members of the fork C² are pivotally connected to the middle-joint, d, of a pair of toggle-levers, D' D², which toggle-levers constitute one of the essential features of my invention, as will more fully appear. The lever D' is pivotally connected to a bracket, d', projecting rearwardly from the bed of the machine, and plays in a slot in said bed, while the lever D² is rigidly connected at its forward end to a pivotal shaft, d², which turns in the end of the horizontal bar I, through which motion is imparted to the four-motion feed-bar K.

Upon one end of the pivotal shaft d² is secured a crank-arm, M, which is pivotally connected to a curved lever, K', fulcrumed at its lower end upon a depending bracket, o, cast with and upon the under side of the bed-plate A³. To the upper end of said lever K' is coupled the bar P, pivotally connected at its forward end to the shuttle-carrier Q, which plays lengthwise of the machine upon guides p p.

Between the bar I and the crank-arm M, and upon the pivot-shaft d², is loosely fitted the lower end of a lever, E, fulcrumed at e to the needle-arm and pivotally connected at its upper end to the needle-bar F. The bar F is similarly coupled at its forward end to the middle joint of a pair of toggles, G G', of which the member G is pivoted or fulcrumed upon the upper part of the head a², while the member G' is pivotally connected to the needle-rod h. The pivot connecting the member G' to the needle-rod has a laterally-extending forked head, h', which embraces and slides upon the presser-bar, the latter serving as a guide to prevent the pin or pivot from turning.

The four-motion feed consists of the flat bar or slide K, having the serrated head k, and having its shank k' arranged within a slot or recess, k², formed in a transverse beam, k³, cast with the bed A. Near the head portion k, and on the under side, the shank k' is recessed at K² for the passage and play of the bar I. The latter near its forward end and upon its upper surface has a cam projection,

2
 3
 4
 5
 6
 7
 8
 9
 10
 11
 12
 13
 14
 15
 16
 17
 18
 19
 20
 21
 22
 23
 24
 25
 26
 27
 28
 29
 30
 31
 32
 33
 34
 35
 36
 37
 38
 39
 40
 41
 42
 43
 44
 45
 46
 47
 48
 49
 50

1', having a lateral extension, 1², which as the bar advances lifts the feed-bar and moves it lengthwise in the direction of the feed of the cloth. When the bar I recedes, the feed-bar K is depressed by the action of a spring, K⁴, located between its upper edge and the under surface of the cloth-plate, and is moved backward by the pressure of a projection, 1⁴, attached to one side of the bar I and contacting in the reverse motion of the bar I against the rear shoulder of the recess K².

Operation: The shaft *a* being turned in either direction, the bar C alternately lifts and depresses the inner ends of the toggles D² D', thus imparting a rectilinear motion to the bar I and a reciprocating vibratory motion to the shuttle-bar P, the bars I and P in turn moving the feed-bar K and the shuttle S in their proper relations and periods. The bar I, being directly coupled to the toggles, has a short movement, while the shuttle-bar P, being connected through the medium of a crank and swinging lever, has a longer movement, or such as is required to propel the shuttle the full length of its race. At the same time the bar or lever E is vibrated, and through its connections imparts vertical reciprocating motion to the needle-rod.

As will be seen, the arrangement and relation of parts is such that two complete stitches are formed with each complete revolution of the main shaft, and thus great speed in operation is attainable, practically producing in fact twice the capacity of machines in which cams, eccentric-gearing, or other devices are employed.

For gaging and determining the length of the stitch, the shank of the bar K is provided with a stud, K³, which in the backward stroke of the bar impinges against the end of a bell-crank or eccentric lever, L, which may be turned so as to shorten or lengthen the stroke.

R' designates a take-up, consisting of a spring-retracted pivotal arm having an eye, through which the thread passes.

U designates the tension device, of the usual or any suitable character.

The needle is fastened to the needle-rod in the following manner: The lower end of said rod is halved vertically. A semi-cylindrical

block, h³, fits the rabbet so formed, and is fastened to the rod by a screw, h⁴. The opposing or juxtaposed faces of the block and rod are V-grooved; forming a rectangular socket for the reception of the shank of the needle, which is fastened after adjustment by tightening the screw.

Having described my invention, what I claim, and desire to secure by Letters Patent, is—

1. The combination, in a sewing-machine, of the main or power shaft, a crank thereon, a pitman connected to said crank, a pair of toggle-arms connected at their middle joint to said pitman, a feed reciprocating bar connected to the free end of one of said toggle-arms, a shuttle-bar, a swinging arm, to which said shuttle-bar is pivotally attached, and a crank or lever connected to said swinging arm and to the free end of said toggle-arm, whereby, when said crank is rotated, said shuttle and feed reciprocating bar will be moved alternately in the same direction, substantially as set forth.

2. The combination, in a sewing-machine, of the main or power shaft, a crank thereon, a pitman connected to said crank, toggle-arms connected to said pitman at their middle joint, a lever fulcrumed on the machine-frame and connected to one of said toggles, a needle-bar-actuating arm pivotally connected to said lever, a vertically-moving needle-bar, and a pair of toggles coupling said needle-bar and arm, substantially as described.

3. In a sewing-machine, the combination, with the horizontally-reciprocating needle-bar-actuating arm, of a pair of toggles, one of which is pivotally connected to the machine-head and the other to the needle-bar, and a pivot passing through the lower member of said toggles and having a forked end which embraces and slides upon the presser-bar, substantially as described.

Signed this 15th day of February, 1886.

EWALD BRÜNCKER.

Witnesses:

F. LEONARDT,
 HENRY SKERRETT.

Both of Birmingham.