



- (51) International Patent Classification:
E21B 43/11 (2006.01) E21B 43/117 (2006.01)
E21B 43/116 (2006.01)
- (21) International Application Number:
PCT/US2017/018357
- (22) International Filing Date:
17 February 2017 (17.02.2017)
- (25) Filing Language: English
- (26) Publication Language: English
- (30) Priority Data:
62/296,308 17 February 2016 (17.02.2016) US
- (71) Applicant: BAKER HUGHES INCORPORATED
[US/US]; 14990 Yorktown Plaza Drive, HOUSTON,
Texas 77040 (US).
- (72) Inventors: GILLIAT, James; 139 Little Mill Place,
Spring, Texas 77382 (US). SATTI, Rajani; 31515 Reston
Cliff Ct., Spring, Texas 77386 (US). ZUKLIC, Stephen;
17702 Ashe Park Ct., Humble, Texas 77346 (US). NEL-
SON, Scott; 19010 Cherry Cove Ln., Cypress, Texas
77433 (US). FLORES, Juan; 62 S. Longford Cir., The

Woodlands, Texas 77382 (US). BRANNON, Harold;
32207 Edgewater Drive, Magnolia, Texas 77354 (US).

- (74) Agents: CARSON, Matt et al.; BAKER HUGHES IN-
CORPORATED, 2001 Rankin Road, HOUSTON, Texas
77073-5114 (US).
- (81) Designated States (unless otherwise indicated, for every
kind of national protection available): AE, AG, AL, AM,
AO, AT, AU, AZ, BA, BB, BG, BH, BN, BR, BW, BY,
BZ, CA, CH, CL, CN, CO, CR, CU, CZ, DE, DJ, DK, DM,
DO, DZ, EC, EE, EG, ES, FI, GB, GD, GE, GH, GM, GT,
HN, HR, HU, ID, IL, IN, IR, IS, JP, KE, KG, KH, KN,
KP, KR, KW, KZ, LA, LC, LK, LR, LS, LU, LY, MA,
MD, ME, MG, MK, MN, MW, MX, MY, MZ, NA, NG,
NI, NO, NZ, OM, PA, PE, PG, PH, PL, PT, QA, RO, RS,
RU, RW, SA, SC, SD, SE, SG, SK, SL, SM, ST, SV, SY,
TH, TJ, TM, TN, TR, TT, TZ, UA, UG, US, UZ, VC, VN,
ZA, ZM, ZW.
- (84) Designated States (unless otherwise indicated, for every
kind of regional protection available): ARIPO (BW, GH,
GM, KE, LR, LS, MW, MZ, NA, RW, SD, SL, ST, SZ,
TZ, UG, ZM, ZW), Eurasian (AM, AZ, BY, KG, KZ, RU,
TJ, TM), European (AL, AT, BE, BG, CH, CY, CZ, DE,
DK, EE, ES, FI, FR, GB, GR, HR, HU, IE, IS, IT, LT, LU,

[Continued on next page]

(54) Title: WELLBORE TREATMENT SYSTEM

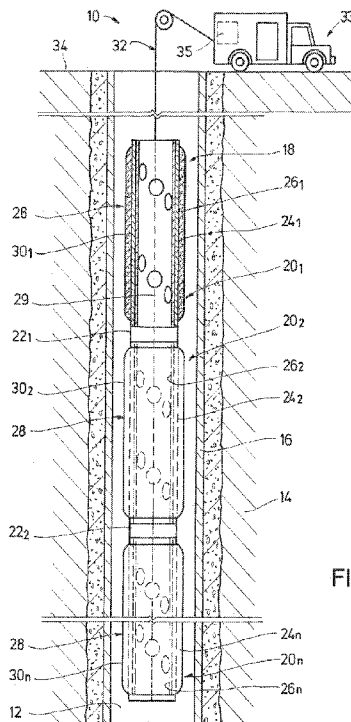

FIG. 1

(57) Abstract: A method and system for treating a wellbore, where an additive casting having energetic material and a treatment substance is deployed downhole, and then the energetic material is reacted so that it releases the treatment substance into the wellbore. A perforating system is used to initiate the reaction of the energetic material. An example of the energetic material includes a propellant that generates gases which urge the treatment substance into openings in sidewalls of the wellbore, such as perforations or fractures. One embodiment of the treatment substance includes a crystalline anhydrous acid.

WO 2017/143181 A1

LV, MC, MK, MT, NL, NO, PL, PT, RO, RS, SE, SI, SK,
SM, TR), OAPI (BF, BJ, CF, CG, CI, CM, GA, GN, GQ,
GW, KM, ML, MR, NE, SN, TD, TG).

— *as to the applicant's entitlement to claim the priority of
the earlier application (Rule 4.17(iii))*

Declarations under Rule 4.17:

— *as to applicant's entitlement to apply for and be granted
a patent (Rule 4.17(ii))*

Published:

— *with international search report (Art. 21(3))*

WELLBORE TREATMENT SYSTEM**CROSS REFERENCE TO RELATED APPLICATIONS**

[0001] This application is a continuation of, and claims priority to and the benefit of, U.S. Provisional Application Serial No. 62/296,308, filed February 17, 2016, the full disclosure of which is hereby incorporated by reference in its entirety herein for all purposes.

BACKGROUND OF THE INVENTION**1. Field of Invention**

[0002] The present disclosure relates in general to a system and method of treating a subterranean wellbore. More specifically, the present disclosure relates to coupling a well treatment substance with energetic material and reacting the energetic material within a wellbore.

2. Description of Prior Art

[0003] Perforating systems are used for the purpose, among others, of making hydraulic communication passages, called perforations, in wellbores drilled through earth formations so that predetermined zones of the earth formations can be hydraulically connected to the wellbore. Perforations are needed because wellbores are typically lined with a string of casing and cement is generally pumped into the annular space between the wellbore wall and the casing. Reasons for cementing the casing against the wellbore wall includes retaining the casing in the wellbore and hydraulically isolating various earth formations penetrated by the wellbore. Sometimes an inner casing string is included that is circumscribed by the casing. Without the perforations oil/gas from the formation surrounding the wellbore cannot make its way to production tubing inserted into the wellbore within the casing.

[0004] Perforating systems typically include one or more perforating guns connected together in series to form a perforating gun string, which can sometimes surpass a thousand feet of perforating length. The gun strings are usually lowered into a wellbore on a wireline or tubing, where the individual perforating guns are generally coupled together by connector subs. Included with the perforating gun are shaped charges that typically include a housing, a liner, and a quantity of high explosive inserted between the liner and the housing. When the high explosive is detonated, the force of the detonation collapses the liner and ejects it from one end of the charge at very high velocity in a pattern called a jet that perforates the casing and the cement and creates a perforation that extends into the surrounding formation. Each shaped charge is typically attached to a detonation cord that runs axially within each of the guns. Wellbore perforating sometimes is typically followed by hydraulic fracturing in order to promote production from the surrounding formation. The extreme pressures generated by the perforating jet often crush and compacts the reservoir rock around each of the perforations; which typically impedes inflow or injection to and from the reservoir. Moreover, the crushed zone can reduce the effective permeability of the reservoir rock by up to 75%. Acid is sometimes used to break down this crushed and compacted rock, and is usually pumped from surface and injected into the perforations.

SUMMARY OF THE INVENTION

[0005] Described herein is a method and system for wellbore operations that include introducing a treatment substance into the wellbore. One example method includes deploying a downhole tool in the wellbore, where the downhole tool includes an additive casting made up of an energetic material and a crystalline anhydrous acid. The downhole tool is positioned adjacent an opening formed in a sidewall of the wellbore, and a reaction of the energetic material is caused to generate an expanding gas that drives the crystalline anhydrous acid into the opening thereby increasing a flow of hydrocarbons through the opening. The downhole tool can further include an explosive, and wherein the step of causing a reaction of the energetic material involves initiating detonation of the explosive so that detonation products of the explosive contact the energetic material at a temperature to initiate reaction of the energetic material. In an alternative, the energetic material is activated concurrent with forming perforations in a sidewall of the wellbore, so that the treatment substance is forced into the perforations by expanding gases created by activation of the energetic material. One embodiment of the downhole tool includes a perforating gun, and wherein the explosive comprises high explosive disposed in a plurality of shaped charges that are set radially inward from the additive casting, so that when high explosive in the shaped charges are detonated, detonation products are generated from detonation of the high explosive that contact the energetic material at a temperature to initiate reaction of the energetic material. In this example, detonation of the shaped charges form perforations in a sidewall of the wellbore, wherein a plurality of openings are formed in the sidewall of the wellbore, and wherein the perforations define the openings. In an alternative, the additive casting is formed into an annular member that circumscribes a portion of the tool. In an optional embodiment, the additive casting is formed into a planar member and disposed inside a body of

the tool. The acid optionally dissolves rock inside of the opening. The energetic material can be a propellant.

[0006] Also disclosed herein is an example of a downhole tool for use in operations in a wellbore and that is made up of a housing, explosive in the housing and that is strategically oriented, so that when the explosive is detonated, detonation products are formed that travel along a designated path, and an additive casting that is intersected by the designated path, the additive casting formed from a solid matrix of a settable material, and an energetic material, and where a wellbore treatment material is embedded within the settable material, so that when a reaction in the energetic material is initiated in the wellbore, the wellbore treatment material is released into the wellbore. The wellbore treatment fluid can be an anhydrous crystalline acid that is reactive with rock that is intersected by a downhole perforation. In an alternative, the energetic material includes a substance that produces energy or pressurized gas when reacted and is selected from the group consisting of a propellant, an oxidizer, ammonium perchlorate, potassium perchlorate, and combinations thereof. An example of the housing is a perforating gun body, wherein the explosive comprises a high explosive within a shaped charge, and wherein detonating the high explosive forms openings in a sidewall of the wellbore. One embodiment of the additive casting is an annular member coupled with the housing. The downhole tool can further include a controller in communication with the explosive.

[0007] Another method of wellbore operations includes disposing an additive casting in the wellbore, the additive casting formed from an energetic material and wellbore treatment material combined in a solid matrix, and introducing the wellbore treatment material into an opening in a sidewall of the wellbore by initiating a reaction of the energetic material that releases the wellbore treatment material from the matrix, and generates a gas that drives the wellbore

treatment material into the opening. The method can further include forming the opening by detonating a shaped charge downhole that is oriented to the sidewall. In one alternative, the additive casting is disposed in a path of detonation product discharged from the shaped charge, and wherein the detonation product is at a temperature that initiates the reaction of the energetic material. An example exists where the wellbore treatment material is a crystalline anhydrous acid that when in the wellbore reconstitutes as a liquid and reacts with rock inside of the opening. An example of the reactive material is a propellant.

BRIEF DESCRIPTION OF DRAWINGS

[0008] Some of the features and benefits of the present invention having been stated, others will become apparent as the description proceeds when taken in conjunction with the accompanying drawings, in which:

[0009] Figure 1 is a partial side sectional view of an example of a wellbore treatment system for use in treating a wellbore.

[0010] Figure 1A is a side sectional view of an example of a shaped charge for use with the wellbore treatment system of Figure 1.

[0011] Figure 2 is a partial side sectional view of the wellbore treatment system forming perforations in the wellbore of Figure 1 and releasing a treatment fluid into the wellbore and the perforations.

[0012] Figure 3 is side partial sectional view of an alternate example of a wellbore treatment system for use in treating a wellbore.

[0013] Figure 4 is side partial sectional view of another alternate example of a wellbore treatment system for use in treating a wellbore.

[0014] While the invention will be described in connection with the preferred embodiments, it will be understood that it is not intended to limit the invention to that embodiment. On the contrary, it is intended to cover all alternatives, modifications, and equivalents, as may be included within the spirit and scope of the invention as defined by the appended claims.

DETAILED DESCRIPTION OF INVENTION

[0015] The method and system of the present disclosure will now be described more fully hereinafter with reference to the accompanying drawings in which embodiments are shown. The method and system of the present disclosure may be in many different forms and should not be construed as limited to the illustrated embodiments set forth herein; rather, these embodiments are provided so that this disclosure will be thorough and complete, and will fully convey its scope to those skilled in the art. Like numbers refer to like elements throughout. In an embodiment, usage of the term “about” includes +/- 5% of the cited magnitude. In an embodiment, usage of the term “substantially” includes +/- 5% of the cited magnitude.

[0016] It is to be further understood that the scope of the present disclosure is not limited to the exact details of construction, operation, exact materials, or embodiments shown and described, as modifications and equivalents will be apparent to one skilled in the art. In the drawings and specification, there have been disclosed illustrative embodiments and, although specific terms are employed, they are used in a generic and descriptive sense only and not for the purpose of limitation.

[0017] An example of a well treatment system 10 is shown in a partial side sectional view in Figure 1. Here the system 10 is used for treating a wellbore 12 that intersects a formation 14. Wellbore 12 is lined with casing 16 which forms a barrier between formation 14 and inside of wellbore 12. Included with the example of the wellbore treatment system 10 is a perforating string 18 shown made up of a string of perforating guns 20_1-20_n , optional connector subs $22_1, 22_2$ couple together adjacent guns 20_1-20_n . The guns 20_1-20_n of the illustrated embodiment include elongate gun bodies 24_1-24_n that have a generally curved outer surface and resemble a cylindrical

shape. Charge tubes 26_1 - 26_n are depicted disposed within each of the gun bodies 24_1 - 24_n . Further in the example of Figure 1, shaped charges 28 are shown mounted within the charge tubes 26_1 - 26_n . Shown in a side sectional view in Figure 1A is an embodiment of a shaped charge 28, and which includes a case C, a liner L set in the case C, and high explosive HE between the case C and liner L. A detonating cord 29 extends within the perforating string 18 (Figure 1) and along a path that runs adjacent a booster charge BC in each of the shaped charges 28. Initiating detonation of the detonating cord 29 forms a detonation wave that travels along a length of the detonation cord 29 and transfers to the booster charges to detonate the high explosive in the shaped charges 28. Example high explosives HE include compositions sold under trade designations HMX, HNS, RDX, PYX and TNAZ.

[0018] Further provided with the example well treatment system 10 of Figure 1 are examples of additive castings 30_1 - 30_n shown as annular members that encompass outer surfaces of the perforating gun bodies 24_1 - 24_n . A wireline 32 is shown mounted to an upper end of a perforating string 18 and is used for raising and lowering perforating string 18 within wellbore 12. Additionally, wireline 32 can provide a communication means between perforating string 18 and a surface truck 33 shown mounted on surface 34 and outside of the wellbore 12. In one alternative, a controller 35 is included, such as in surface truck 33, and that is in selective communication with wireline 32 for controlling operation of perforating string 18. In an optional embodiment, wireline 32 couples to a motorized reel (not shown) for raising/lowering wireline 32 in wellbore 12. In an example motorized reel mounts to surface truck 33. In a non-limiting example of operation, perforating string 18 communicates to surface truck 33 and/or controller 35 via wireline 32. Optionally, other means of conveying and signaling perforating string 18 may be employed, such as coiled tubing, cables, slick line, and the like.

[0019] Figure 2 shows in a side partial sectional view an example of the shaped charges 28 of Figure 1 having been detonated, such as from a signal via wireline 32 from surface truck 33 or controller 35, and which have formed perforations 36 that project radially out from the wellbore 12, through the casing 16, and into the formation 14. Openings 38 in the sidewall of each of the gun bodies 24₁-24_n are also formed by detonating the shaped charges 28. Referring back to Figure 1, in an example the additive castings 30₁-30_n are substantially solid members whose constituents include an energetic material and a treatment substance. Examples of the energetic material include any substance that produces energy or pressurized gas when reacted, such as a propellant, oxidizers, ammonium perchlorate, potassium perchlorate, any other reactive material, and combinations thereof. Examples of the treatment substance include anything used for treating the wellbore 12, such as an acid, crystalline acids, anhydrous acids, crystalline anhydrous acids, brine, a surfactant, a salt, a polysaccharide, corrosion inhibitors, and combinations thereof. Some examples of suitable crystalline anhydrous acids and salts that produce acids when dissolved include, but are not intended to be limited to, acetic anhydride, citric acid anhydride, sulfamic acid anhydride, benzoic acid, benzoic acid flakes, hydrochloric acid, hydrofluoric acid, phthalic acid, phthalic anhydride, terephthalic acid, terephthalic anhydride, sulfuric acid anhydride, polylactic acid, boric acid, ammonium bifluoride, potassium bifluoride, ethylenediaminetetraacetic acid, lactic acid, along with combinations and mixtures thereof. In an alternative, the treatment substance is encapsulated in a shell (not shown) that dissolves/degrades when exposed to conditions/fluids downhole. Examples exist wherein the treatment substances dissolve in connate fluid, water based drilling fluids, oil based drilling fluids, and combinations thereof.

[0020] In a non-limiting example of operation, the shaped charges 28 of Figure 1 are oriented so that when explosives within the shaped charges 28 are detonated, detonation products generated by the detonation are directed towards the additive casting 30₁-30_n. An example of the detonation products includes gas at high pressure and/or temperature that initiate a corresponding reaction of the energetic material in the additive casting 30₁-30_n. Reacting the energetic material releases the treatment substance from the additive casting 30₁-30_n, and into the wellbore 12. In the example of Figure 2, the treatment substance takes the form of a treatment fluid 40 when released from the castings 30₁-30_n. The treatment fluid 40 is shown in wellbore 12 and entering perforations 36. In one non limiting example, a crystalline acid, such as an anhydrous crystalline acid, was bound to an energetic gas generating material, such as potassium perchlorate and then molded to form castings 30₁-30_n and combined with the perforating gun bodies 24₁-24_n. As the propellant in the castings 30₁-30_n reacts to the detonation of the shaped charges 28, energy is generated, that in an example includes high velocity gases, that carries or urges the crystalline acid into the perforations 36, and where the acid begins to react with the crushed and compacted rock that surrounds the perforations 36. Depending on the acid blend, calcareous components of the crushed rock are dissolved, as well as the matrix itself. This results in a removal of the crushed and compacted rock, which reduces the overall formation skin. Optionally, a fuel, such as a plastic resin, can be used in combination with the energetic gas generating materials to enhance reaction of the propellant. Examples of the reaction of the propellant include combustion, burning, ignition, and detonation. Alternatively, the charge tubes 26₁-26_n could be formed from the cast material of the propellants/energetic material in the additive substance. Optionally, the combination of cast energetic material and treatment substance can be positioned

within the gun bodies 24₁-24_n in any shape or form. The treatment method described herein can be performed with or without packers (not shown).

[0021] Figure 3 shows an alternate example of a well treatment system 10A where the perforating string 18A is disposed in wellbore 12 and shown having additive castings 30A₁-30A_n disposed within the annular gun bodies 24A₁-24A_n. In this example, the additive castings 30A₁-30A_n are disk like members and placed adjacent the shaped charges 28A disposed within the gun bodies 24A₁-24A_n. The operational sequence of the embodiment of the well treatment system 10A of Figure 3 is much the same as that of the system 10 of Figure 1, that is detonation of the shaped charges 24A₁-24A_n in turn causes initiation of a reaction of the additive castings 30A₁-30A_n, thereby releasing a treatment substance into the wellbore 12. However, other means of initiation reaction of the energetic material can be employed, such as electricity (*i.e.* via wireline 32) or from a detonation wave from detonation cord 29A in the perforating string 18A.

[0022] Another alternate example of a well treatment system 10B is shown in a side partial sectional view in Figure 4. In this example, the additive casting 30B is an elongate cylindrical member disposed on an end of wireline 32 and set within wellbore 12. Here, perforations 36 have already been formed within the formation 14. In this example, a signal from the surface truck 33 via wireline 32 makes it way to the additive casting 30B to initiate a reaction of the energetic material making up the casting 30B, and thereby releasing the treatment substance into the wellbore 12 and into perforations 36.

[0023] In one non-limiting example of forming an additive casting 30, the energetic material is bound to a settable material, combined with a wellbore treatment material, and then molded into a desired shape, such as the annular shape of the additive casting 30 of Figure 1. Example

settable materials include thermosetting polymers, resins, thermosetting resins, acrylic resins, polyesters, vinyl esters, epoxy, polyurethane, phenolic resins, amino resins, furan resins, any other material that is moldable and then hardens, and combinations thereof. An alternate embodiment of forming the casting 30 includes mixing a liquid-form resin with a powdered composition of crystalline acid and a propellant, and molding the mixture into a disk or other shape. The propellant/acid disk is then placed adjacent to conventional shaped charges within a perforating gun assembly. Alternatively, the propellant/acid combination is cast as a cylinder (casting 30B of Figure 4) and conveyed downhole to treat a previously perforated wellbore. In this example, reaction of the propellant is initiated by means other than a shaped charge, such as by a detonating cord or other suitable initiator. Other components, such as wellbore treatment materials, which include acids, anhydrous acids, crystalline acids, and anhydrous crystalline acids, are optionally blended into the mixture of the energetic material and resin. Thus the gas generated by an oxidation process of the energetic material urges the acid into the perforations 36, and the energetic material is a conveyance or delivery method rather than a stimulation tool. In one alternate embodiment, the acid/energetic material composition is cast into tubes and placed inside perforation gun bodies 24₁-24_n (Figure 1).

[0024] One example propellant for use in the casings described above includes potassium perchlorate. In this example, detonating a perforating gun generates extreme pressure and heat that ignite the propellant material. As the propellant material combusts or burns a high-velocity gas is generated which carries the crystalline acid into the perforations. Inside the perforations the acid reconstitutes as a liquid acid that reacts with the crushed and compacted rock surrounding the perforation tunnels. Depending upon the type or blend of crystalline acid, the calcareous components of the crushed rock can be dissolved or the rock matrix itself can be

removed. This eventually leads to the removal of crushed and compacted rock, thereby improving hydraulic communication between the formation 14 and wellbore 12 through the perforations 36 (Figure 2). A significant advantage realized by the present disclosure is that costly equipment for pumping wellbore treatment fluids downhole is not required. Another advantage is that the amount of wellbore treatment fluids or material can be greatly reduced as well as an excessive amount of wellbore treatment fluid is consumed when being pumped downhole. Typical acidizing treatment operations require many hundreds of liters of acid, whereas implementation of the presently disclosed technique is expected to require only grams of treatment substance.

[0025] The present invention described herein, therefore, is well adapted to carry out the objects and attain the ends and advantages mentioned, as well as others inherent therein. While a presently preferred embodiment of the invention has been given for purposes of disclosure, numerous changes exist in the details of procedures for accomplishing the desired results. For example, in an embodiment, additive castings 30₁-30_n of Figure 1 are inserted within the gun bodies 24₁-24_n. In another alternative, charge tubes 26₁-26_n are formed from the same material as 30₁-30_n. These and other similar modifications will readily suggest themselves to those skilled in the art, and are intended to be encompassed within the spirit of the present invention disclosed herein and the scope of the appended claims.

CLAIMS

What is claimed is.

1. A method of operations in a wellbore comprising:

deploying a downhole tool in the wellbore, the downhole tool comprising an additive casting that comprises an energetic material and a crystalline anhydrous acid;

positioning the downhole tool at a designated depth in the wellbore; and

causing a reaction of the energetic material to generate energy that drives the crystalline anhydrous acid into an opening formed in a sidewall of the wellbore thereby increasing a flow of hydrocarbons through the opening.
2. The method of Claim 1, wherein the downhole tool further comprises an explosive, and wherein the step of causing a reaction of the energetic material comprises initiating detonation of the explosive so that detonation products of the explosive contact the energetic material at a temperature to initiate reaction of the energetic material.
3. The method of Claim 1, wherein the energy is from expanding gas produced by the reaction of the energetic material, and wherein the energetic material is reacted concurrent with forming perforations in a sidewall of the wellbore, so that the treatment substance is forced into the perforations by the expanding gas.
4. The method of Claim 3, wherein the downhole tool comprises a perforating gun, and wherein the explosive comprises high explosive disposed in a plurality of shaped charges that are set radially inward from the additive casting, so that when high explosive in the shaped charges

are detonated, detonation products are generated from detonation of the high explosive that contact the energetic material at a temperature to initiate reaction of the energetic material.

5. The method of Claim 4, wherein detonation of the shaped charges form perforations in a sidewall of the wellbore, wherein a plurality of openings are formed in the sidewall of the wellbore, and wherein the perforations define the openings

6. The method of Claim 1, wherein the additive casting is formed into an annular member that circumscribes a portion of the tool.

7. The method of Claim 1, wherein the additive casting is formed into a planar member and disposed inside a body of the tool.

8. The method of Claim 1, wherein the acid dissolves rock inside of the opening.

9. The method of Claim 1, wherein the energetic material comprises a propellant.

10. A downhole tool for use in operations in a wellbore comprising:

a housing;

explosive in the housing and that is strategically oriented, so that when the explosive is detonated, detonation products are formed that travel along a designated path; and

an additive casting that is intersected by the designated path, the additive casting comprising a solid matrix of a settable material, and an energetic material and a wellbore treatment material embedded within the settable material, so that when a reaction in the energetic material is initiated in the wellbore, the wellbore treatment material is released into the wellbore.

11. The downhole tool of Claim 10, wherein the wellbore treatment fluid comprises an anhydrous crystalline acid that is reactive with rock that is intersected by a downhole perforation.
12. The downhole tool of Claim 10, wherein the energetic material comprises a substance that produces energy or pressurized gas when reacted and is selected from the group consisting of a propellant, an oxidizer, ammonium perchlorate, potassium perchlorate, and combinations thereof.
13. The downhole tool of Claim 10, wherein the housing comprises a perforating gun body, wherein the explosive comprises a high explosive within a shaped charge, and wherein detonating the high explosive forms openings in a sidewall of the wellbore.
14. The downhole tool of Claim 13, wherein the additive casting comprises an annular member coupled with the housing.
15. The downhole tool of Claim 10, further comprising a controller in communication with the explosive.
16. A method of wellbore operations comprising:
 - disposing an additive casting in the wellbore, the additive casting comprising an energetic material and wellbore treatment material combined in a solid matrix; and
 - introducing the wellbore treatment material into an opening in a sidewall of the wellbore by initiating a reaction of the energetic material that releases the wellbore treatment material from the matrix, and generates a gas that drives the wellbore treatment material into the opening.

17. The method of Claim 16, further comprising forming the opening by detonating a shaped charge downhole that is oriented to the sidewall.
18. The method of Claim 17, wherein the additive casting is disposed in a path of detonation product discharged from the shaped charge, and wherein the detonation product is at a temperature that initiates the reaction of the energetic material.
19. The method of Claim 16, wherein the wellbore treatment material comprises a crystalline anhydrous acid that when in the wellbore reconstitutes as a liquid and reacts with rock inside of the opening.
20. The method of Claim 16, wherein the reactive material comprises a propellant.

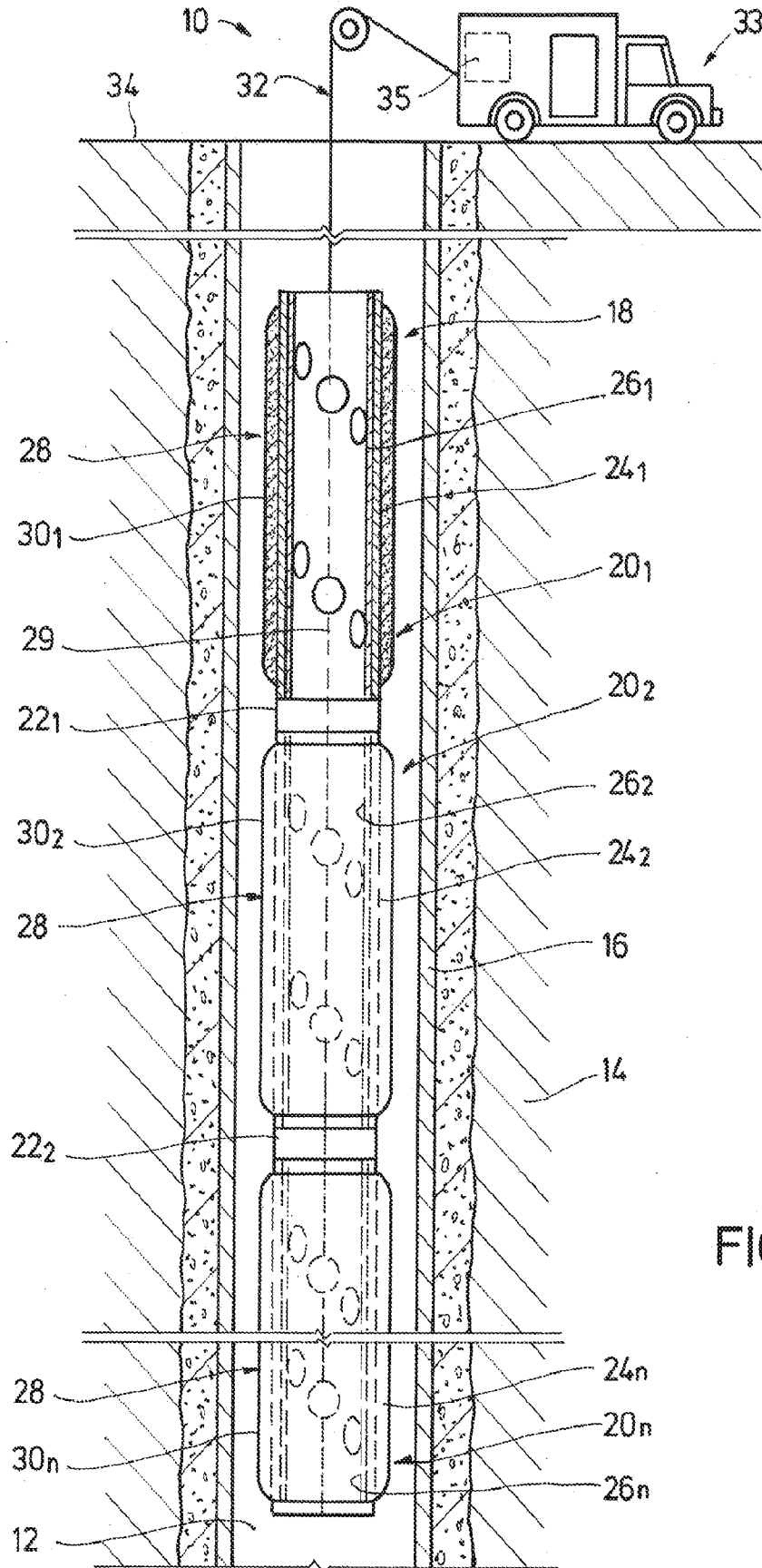

FIG. 1

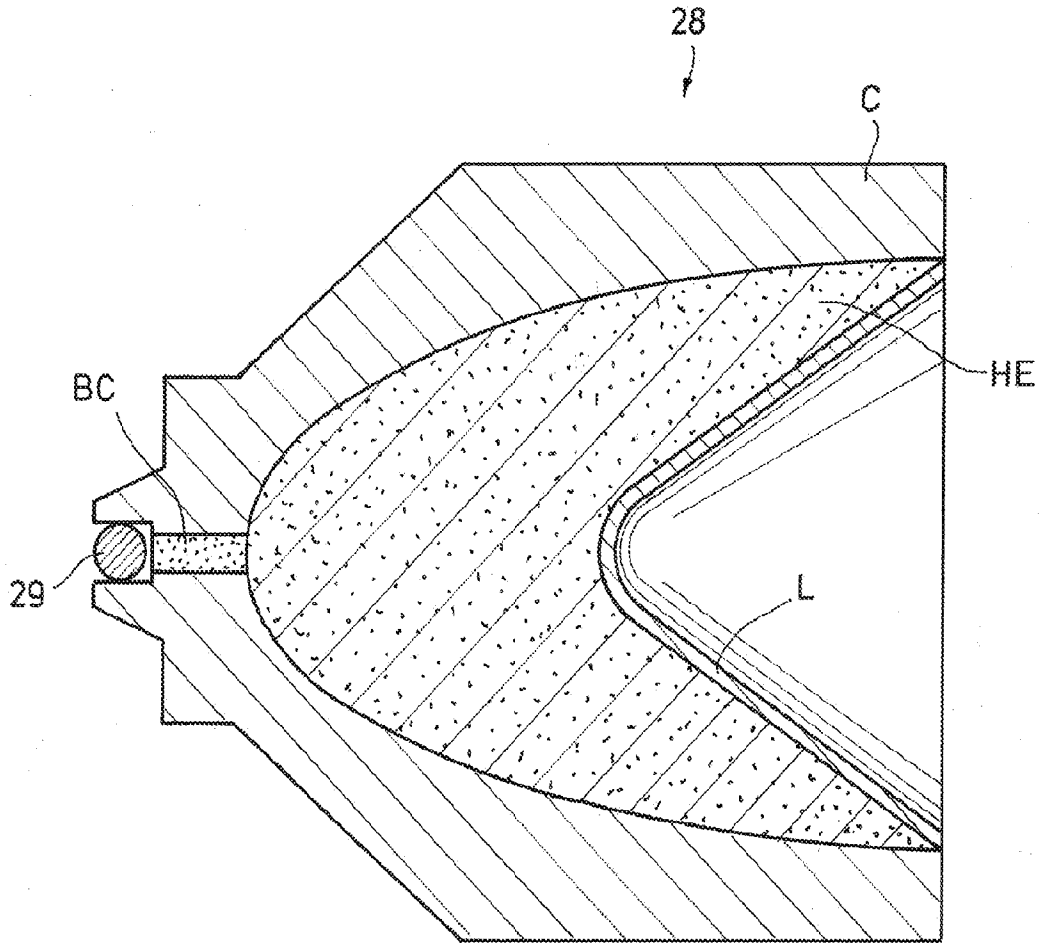

FIG. 1A

3/4

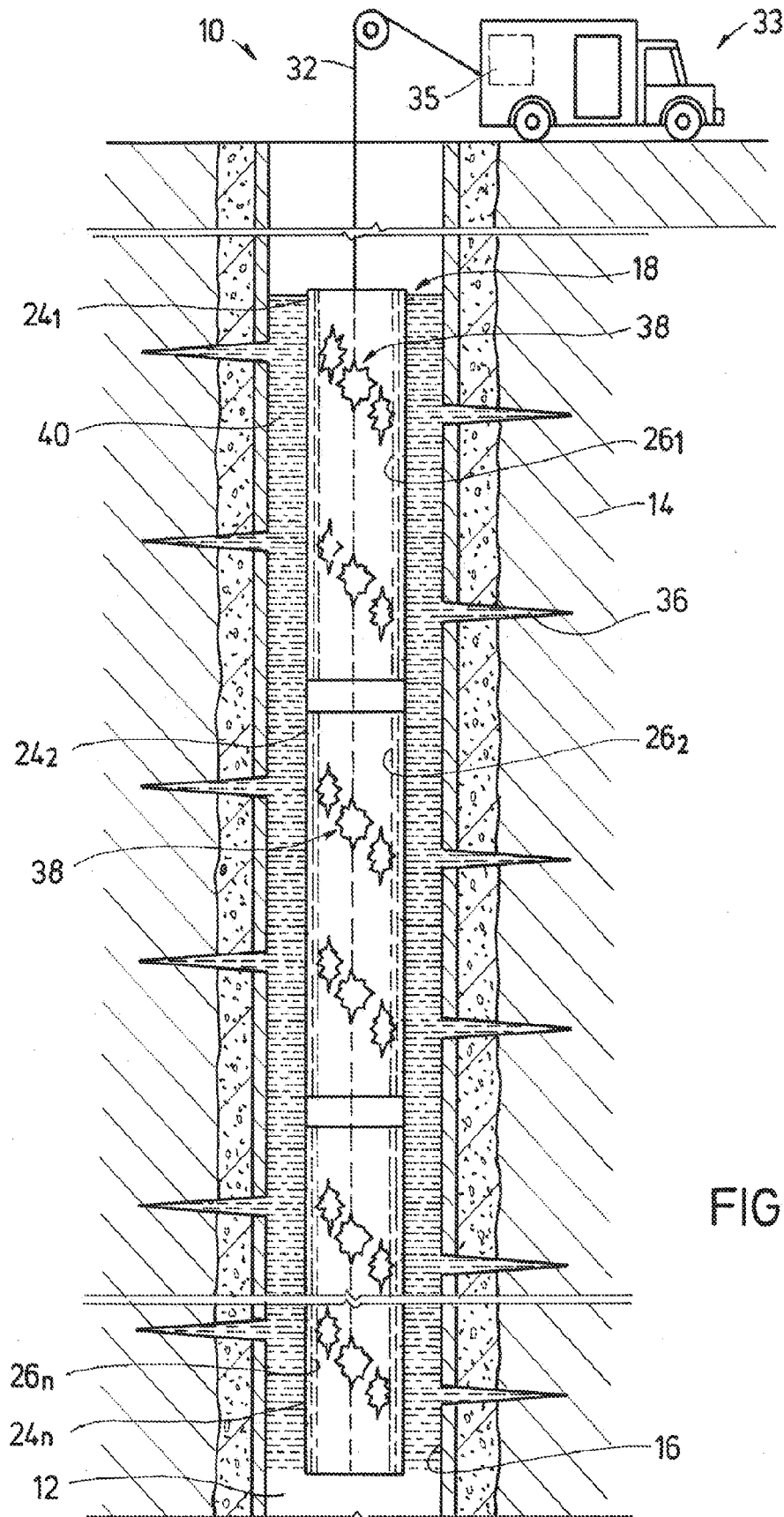

FIG.2

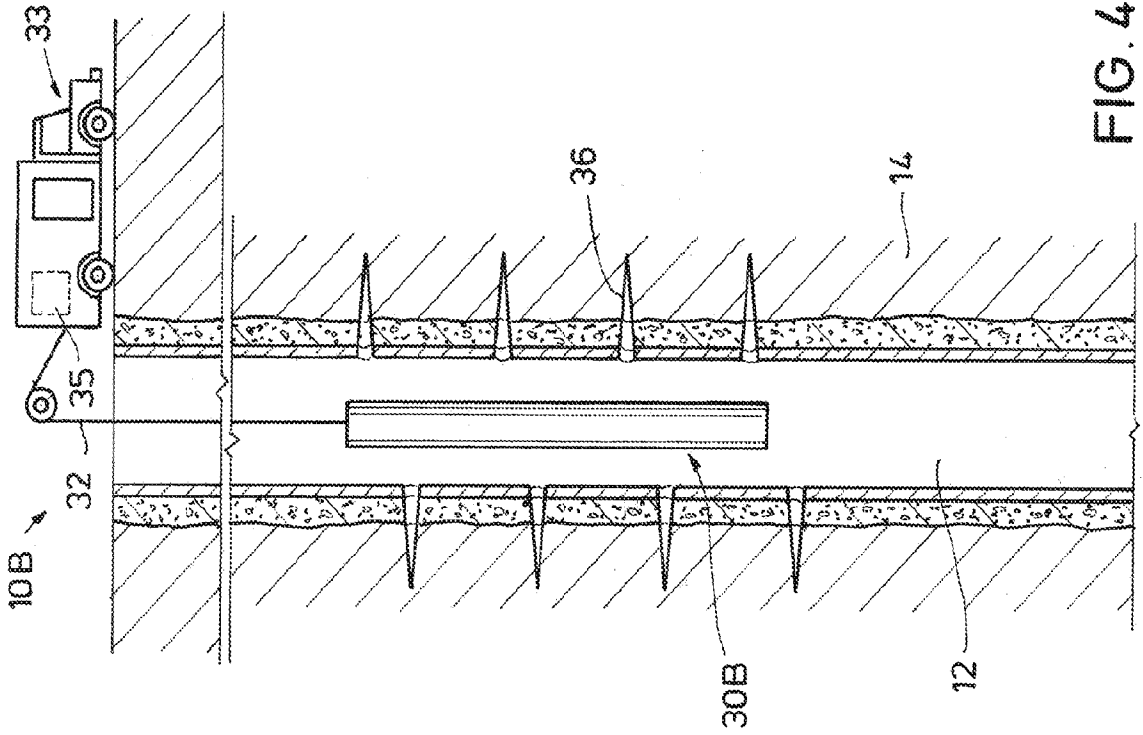

FIG. 4

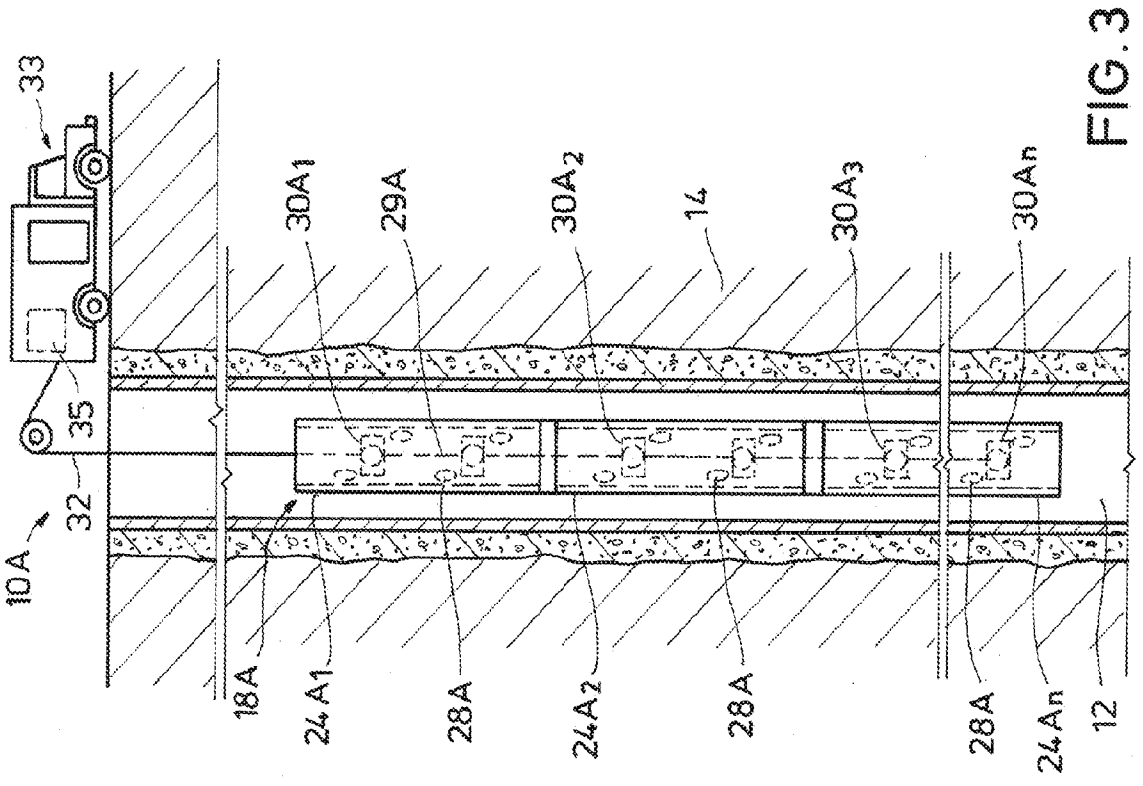

FIG. 3

A. CLASSIFICATION OF SUBJECT MATTER**E21B 43/11(2006.01)i, E21B 43/116(2006.01)i, E21B 43/117(2006.01)i**

According to International Patent Classification (IPC) or to both national classification and IPC

B. FIELDS SEARCHED

Minimum documentation searched (classification system followed by classification symbols)

E21B 43/11; E21B 43/12; E21B 47/00; F42D 1/00; E21B 43/26; E21B 43/117; E21B 43/16; E21B 29/02; E21B 43/116

Documentation searched other than minimum documentation to the extent that such documents are included in the fields searched

Korean utility models and applications for utility models

Japanese utility models and applications for utility models

Electronic data base consulted during the international search (name of data base and, where practicable, search terms used)

eKOMPASS(KIPO internal) & Keywords:

downhole tool, energetic material, wellbore treatment fluid, additive casting, opening, explosive

C. DOCUMENTS CONSIDERED TO BE RELEVANT

Category*	Citation of document, with indication, where appropriate, of the relevant passages	Relevant to claim No.
Y	WO 2015-009753 A1 (LOS ALAMOS NATIONAL SECURITY, L.L.C.) 22 January 2015 See page 1, line 19 - page 47, line 10; and figures 1-7.	1-20
Y	US 2013-0056269 A1 (XU, ZHIYUE) 07 March 2013 See paragraphs [0004]-[0056]; and figures 1-9.	1-20
A	WO 2014-179676 A1 (SCHLUMBERGER CANADA LIMITED et al.) 06 November 2014 See paragraphs [0002]-[0050]; and figures 1, 2A-2D, 3A-3B, 4A-4B, 5-6.	1-20
A	US 2009-0114382 A1 (GROVE, BRENDEN) 07 May 2009 See paragraphs [0002]-[0035]; and figures 1-5, 5A-5B, 6-9.	1-20
A	US 2008-0210422 A1 (CLARK et al.) 04 September 2008 See paragraphs [0002]-[0040]; and figures 1-4, 5A-5F, 6, 7A-7C.	1-20

 Further documents are listed in the continuation of Box C. See patent family annex.

* Special categories of cited documents:

"A" document defining the general state of the art which is not considered to be of particular relevance

"E" earlier application or patent but published on or after the international filing date

"L" document which may throw doubts on priority claim(s) or which is cited to establish the publication date of another citation or other special reason (as specified)

"O" document referring to an oral disclosure, use, exhibition or other means

"P" document published prior to the international filing date but later than the priority date claimed

"T" later document published after the international filing date or priority date and not in conflict with the application but cited to understand the principle or theory underlying the invention

"X" document of particular relevance; the claimed invention cannot be considered novel or cannot be considered to involve an inventive step when the document is taken alone

"Y" document of particular relevance; the claimed invention cannot be considered to involve an inventive step when the document is combined with one or more other such documents, such combination being obvious to a person skilled in the art

"&" document member of the same patent family

Date of the actual completion of the international search

26 May 2017 (26.05.2017)

Date of mailing of the international search report

26 May 2017 (26.05.2017)

Name and mailing address of the ISA/KR

International Application Division

Korean Intellectual Property Office

189 Cheongsa-ro, Seo-gu, Daejeon, 35208, Republic of Korea

Facsimile No. +82-42-481-8578

Authorized officer

LEE, Se Gyoung

Telephone No. +82-42-481-8740



INTERNATIONAL SEARCH REPORT

Information on patent family members

International application No.

PCT/US2017/018357

Patent document cited in search report	Publication date	Patent family member(s)	Publication date
WO 2015-009753 A1	22/01/2015	US 2016-0153271 A1	02/06/2016
US 2013-0056269 A1	07/03/2013	US 9133695 B2	15/09/2015
		WO 2013-033542 A2	07/03/2013
		WO 2013-033542 A3	25/04/2013
WO 2014-179676 A1	06/11/2014	EP 2992178 A1	09/03/2016
		EP 2992178 A4	23/11/2016
		US 2016-0076326 A1	17/03/2016
US 2009-0114382 A1	07/05/2009	CN 101382060 A	11/03/2009
		US 7909115 B2	22/03/2011
US 2008-0210422 A1	04/09/2008	AT 551494 T	15/04/2012
		AU 2008-222330 A1	12/09/2008
		AU 2008-222330 B2	18/08/2011
		CA 2679561 A1	12/09/2008
		CA 2679561 C	12/11/2013
		EA 016442 B1	30/05/2012
		EA 200970826 A1	30/04/2010
		EP 2118437 A2	18/11/2009
		EP 2118437 B1	28/03/2012
		MX 2009009339 A	22/09/2009
		PL 2118437 T3	31/07/2012
		US 7909096 B2	22/03/2011
		WO 2008-107826 A2	12/09/2008
		WO 2008-107826 A3	13/11/2008