

(72) KOTTMANN, Norbert, DE
(71) KOTTMANN, Norbert, DE
(51) Int.Cl.⁶ B02C 13/20, B27L 11/00
(30) 1998/10/21 (198 47 886 0) DE
(54) **APPAREIL DE COMMINUTION**
(54) **COMMINUTING APPARATUS**

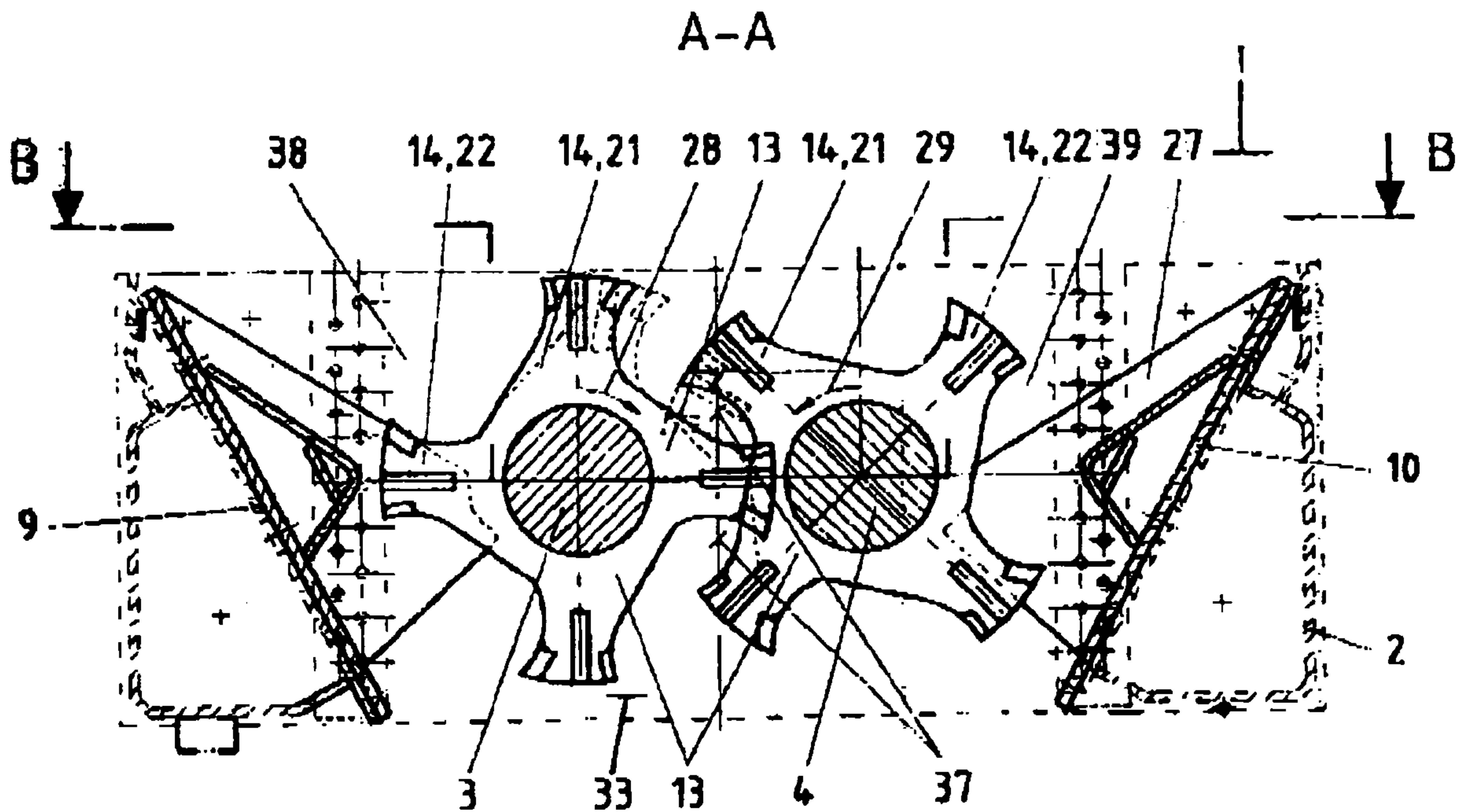

Field of Application of the Invention

The invention concerns a crushing unit for wood, refuse and other breakable, tearable or workable waste.

Characteristics of the known Prior Art

Slowly running crushing devices or crushing plants with 2 parallel tool shafts that have disk-like tool carriers with mounted or installed crushing tools, were disclosed in the prior art.

The crushing devices or crushing plants used in this way are disadvantageous because they primarily crush or tear the material to be comminuted in only one operating direction of rotation of the crushing shafts and thus only in one working range and, especially during the crushing of refuse, are only cleared dependent on adherent materials during the reversing movement. A mode of operation of this type results therein that a relatively large quantity of material is compressed between the shafts which, in turn, negatively affects the take-in behaviour of the crushing tools, reduces the throughput capacity and negatively affects the power input per Mg of crushed material.

Object of the Invention

The object of the invention is a crushing unit of the aforementioned type that reduces and eliminates the disadvantages of the prior art, has a simple structure and has low technological demands and space requirement, whereby the routine expenditures during practical use are low. The novel crushing unit should have 3 crushing areas and crush in both directions of rotation of the tool shafts during crushing or tearing or reduce the volume during working of non-breakable or non-tearable materials. The novel crushing unit should thereby be in the form of a reciprocal unit and it should be possible to use it in various crushings.

Description of the Nature of the Invention

The object of the invention is to provide a crushing unit that can optionally carry out two different methods of operation corresponding to the properties of the material to be crushed.

According to the invention, this object is solved thereby that a complete arrangement consists of a housing and a crushing area and that the housing contains a left bearing plate, a right bearing plate, a left reinforcing, supporting and holdback plate with clearing and crushing prongs and a right reinforcing, supporting and holdback plate with clearing and crushing prongs and that the housing has a bearing area and a coupling area and that the bearing area has a support and a right bearing and that the coupling area has a left outer coupling half and a right outer coupling half that are both attached to the crushing shafts and that the crushing unit consists of a left crushing shaft and a right crushing shaft,

the left and right clearing and crushing prongs, whereby the left crushing shaft is accommodated by the left fixed bearing and has a left outer coupling half that is accommodated by a left coupling pin and that the right crushing shaft is accommodated by the right fixed bearing and has a right outer coupling half that is accommodated by a right coupling pin and that tool carriers (13) sit on the crushing shafts and have tool heads that in turn have clearing devices in clearing seats (16), front wear inserts in front insert seats and rear wear inserts (19) in rear insert seats.

Example of an Embodiment
("Crushing Unit")

The invention shall be described in greater detail with reference to the following drawings that, in detail, show:

- Fig. 1: a basic representation of a complete arrangement of a novel crushing unit according to the invention, in a front view along the section A - A in Figure 2,
- Fig. 2: a basic representation of a complete arrangement of a novel crushing unit according to the invention, in a top view along the section B - B in Figure 1,
- Fig. 3: a basic representation of a novel tool carrier according to the invention, in a side view,
- Fig. 4: a basic representation of a novel tool carrier according to the invention, in a front view of Figure 3,

Fig. 5: a basic representation of a tool carrier according to the invention as an unfinished part, in a front view,

Fig. 6: a basic representation of a complete arrangement of a tool carrier according to the invention, as a detail X of Figure 1,

Fig. 7: a basic representation of a complete arrangement of a novel crushing unit according to the invention, in a top view along the section B - B in Figure 1, with clearing spacings (46).

Patent Claims

1. Crushing unit, characterized therein that a complete arrangement (1) consists of a housing (2) and a crushing area (33) and that the housing (2) comprises a left bearing plate (9), a right bearing plate (10), a left reinforcing, bearing and holdback plate (11) with clearing and crushing prongs (27) and a right reinforcing, bearing and holdback plate (12) with clearing and crushing prongs (27) and that the housing (2) has a bearing area (34) and a coupling area (35) and that the bearing area (34) has a bearing (5) and a right bearing (6) and that the coupling area (35) has a left outer coupling half (7) and a right outer coupling half (8) that are both attached to the crushing shafts (3 and 4) and that the crushing unit (33) consists of a left crushing shaft (3) and a right crushing shaft (4), the left and right clearing and crushing prongs (27), whereby the left crushing shaft (3) is accommodated by a left fixed bearing (5) and has a left outer coupling half (7) that is accommodated by a left coupling pin (42) and that the right crushing shaft (4) is accommodated by the right fixed bearing (6) and has a right outer coupling half (8) that is accommodated by a right coupling pin and that tool carriers (13) sit on the crushing shafts (3 and 4) that have tool heads (14) that in turn have clearing devices (15) in clearing seats (16), front wear inserts (17) in front wear insert seats (18) and rear wear inserts (19) in rear wear insert seats (20).
2. Crushing unit according to claim 1, characterized therein that the left crushing shaft (3) is equipped with 3, 4,

5, 6, 7, 8, 9 or 10 tool carriers (13) and the right crushing shaft (4) with 3, 4, 5, 6, 7, 8, 9 or 10 tool carriers (13).

3. Crushing unit according to claim 1, characterized therein that the tool carrier (13) has 2, 3, 4, 5, 6, 7 or 8 tool heads (14) and that the number of tool heads (14) also determine the grain size of the output.
4. Crushing unit according to claim 1 or 2, characterized therein that a clearing and crushing prong (27) is arranged between each of the tool carriers (13) in the left crushing area (38).
5. Crushing unit according to claim 1 or 2, characterized therein that a clearing and crushing prong (27) is arranged between each of the tool carriers (13) in the right crushing area (39).
6. Crushing unit according to claim 1 or 2, characterized therein that an intermediate crushing area (37), formed by the left crushing shaft (3) and the right crushing shaft (4), is located in the crushing area (33), whereby the left crushing shaft (3) crushes in the operating direction of rotation (28) and the right crushing shaft (4) crushes in the opposite direction of rotation (29) and that both shafts move synchronously in opposite direction.
7. Crushing unit according to claim 1, characterized therein that an intermediate crushing area (37), formed by the left crushing shaft (3) and the right crushing shaft (4), is located in the crushing area (33), whereby the left

crushing shaft (3) crushes in the operating direction of rotation (28) and the right crushing shaft (4) crushes in the opposite direction of rotation (29), that a clearing spacing (46) is formed between the clearing devices (15) of the left crushing shaft (3) and the clearing devices (15) of the right crushing shaft (4) and that both shafts move synchronously in opposite direction.

8. Crushing unit according to claim 1, characterized therein that a left crushing area (38) is formed in the crushing area (33) and that the left crushing area (38) comprises the left crushing shaft (3) with tool carriers (13) and clearing devices and crushers (not shown in greater detail), with the left bearing plate (9), the left reinforcing, bearing and holdback plate (11) as well as the left clearing and crushing prongs (27), whereby the clearing and crushing prongs (27) are intended for use between the tool carriers (13).
9. Crushing unit according to claim 1, characterized therein that a right crushing area (39) is formed in the crushing area (33) and that the right crushing area (39) comprises the right crushing shaft (4) with tool carriers (13) and clearing devices and crushers (not shown in greater detail), with the right bearing plate (10), the right reinforcing, bearing and holdback plate (12) as well as the right clearing and crushing prongs (27), whereby the clearing and crushing prongs (27) are intended for use between the tool carriers (13).
10. Crushing unit according to claims 1 to 8, characterized therein that the width of the clearing and crushing prongs (27) is variable and that, with a low number of

tool carriers (13) per crushing shaft (3 and 4), with an operating direction of rotation of the shafts in opposite directions (28) in the left and right crushing area (38 and 39), a different grain size of the output is obtained than in the intermediate crushing area (37), that is that the grain size and throughput capacity are already determined by the selection of the operational direction of rotation of the crushing shafts (3 and 4) without changing the crushing shafts (3 and 4) and the clearing devices and crushers (not shown in greater detail).

11. Crushing unit according to claim 1, characterized therein that the clearing angle (36) is less or greater than 0° ($<> 0^\circ$).
12. Crushing unit according to claim 1, characterized therein that clearing devices (15) consist of an impact-resistant material.
13. Crushing unit according to claim 1, characterized therein that the clearing device (15) is fastened to the tool carrier (13) by welding, screwing or pinning.
14. Crushing unit according to claim 1 to 4, characterized therein that the front wear insert (17) and the rear wear insert (19) consist of an impact-resistant material.
15. Crushing unit according to claim 1 to 6, characterized therein that the difference between the inside active diameter (40) and an outside active diameter (41) is greater than 1 millimeter and results in a good tearing behaviour due to the varying peripheral speed of the tool heads (14).

16. Crushing unit according to claim 1 to 16, characterized therein that the tool carrier (13) has a high tool head (21) and one or more low tool heads (22).
17. Crushing unit according to claim 1 to 16, characterized therein that the tool carrier (13) can have one or more high tool heads (21) and one or more low tool heads (22) in any order desired.
18. Crushing unit according to claim 1, characterized therein that the rotational speed of the left crushing shaft (3) and the right crushing shaft (4) is between 0 and 60 revolutions/minute, in particular, that it has a size of 0 to 30 revolutions/minute and that a continuous flow of material is ensured in all speed ranges.
19. Crushing unit according to claim 1, characterized therein that the throughput of the crushing unit can be regulated according to the desired throughput quantity by means of the variable speed.
20. Crushing unit according to claim 1 to 10, characterized therein that the crushing burr is also determined by the speed selection.
21. Crushing unit according to claim 1 to 10, characterized therein that the clearing devices (15) fastened in the high tool heads (21) do not exceed the outer sphere of action (31) and that the clearing devices (15) fastened in the low tool heads (22) do not exceed the inner sphere of action (30).

22. Crushing unit according to claim 1 to 10, characterized therein that the clearing devices (15) do not have any knife-shaped or wedge-shaped formations.

Fig. 1

A-A

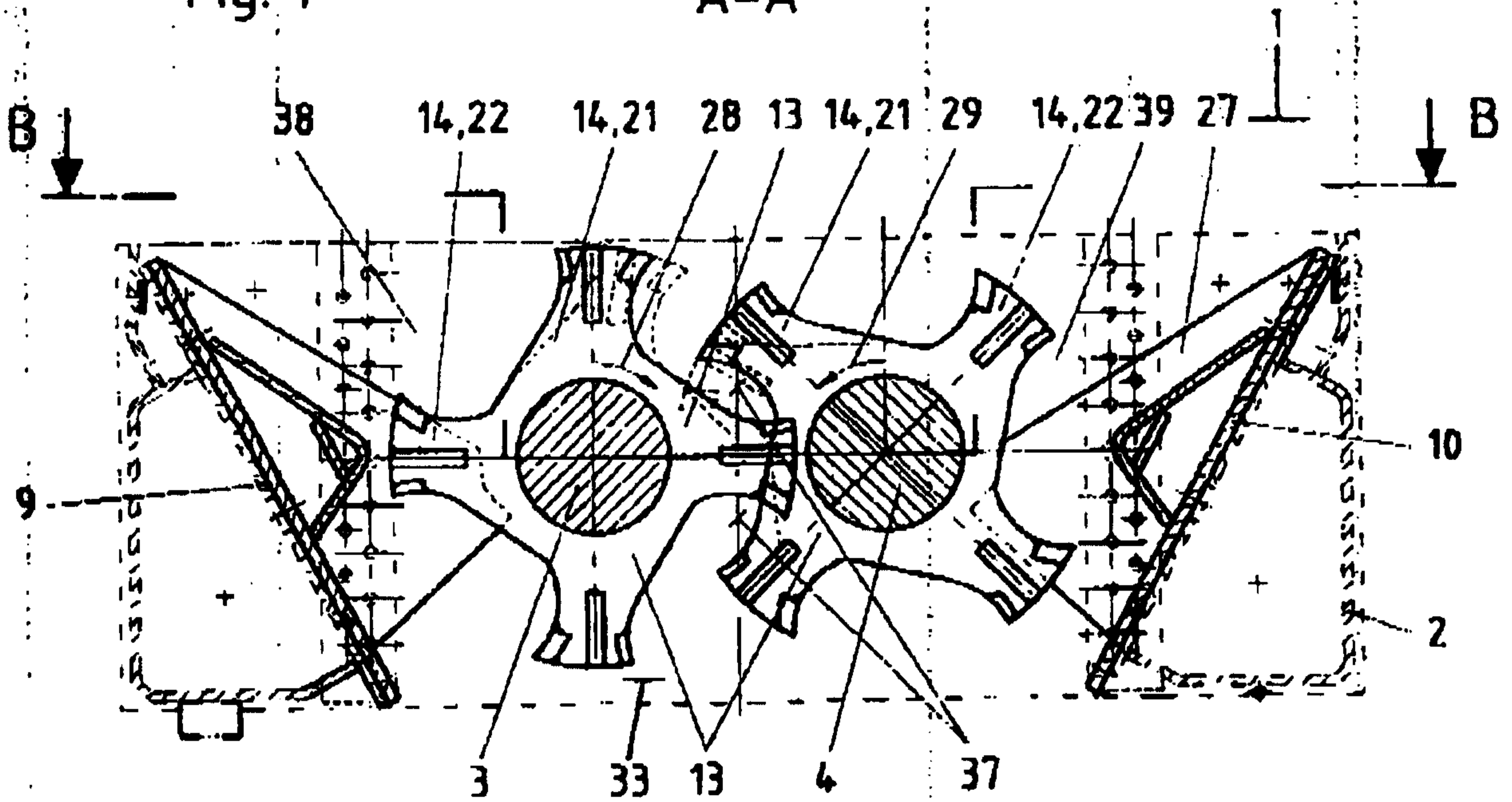
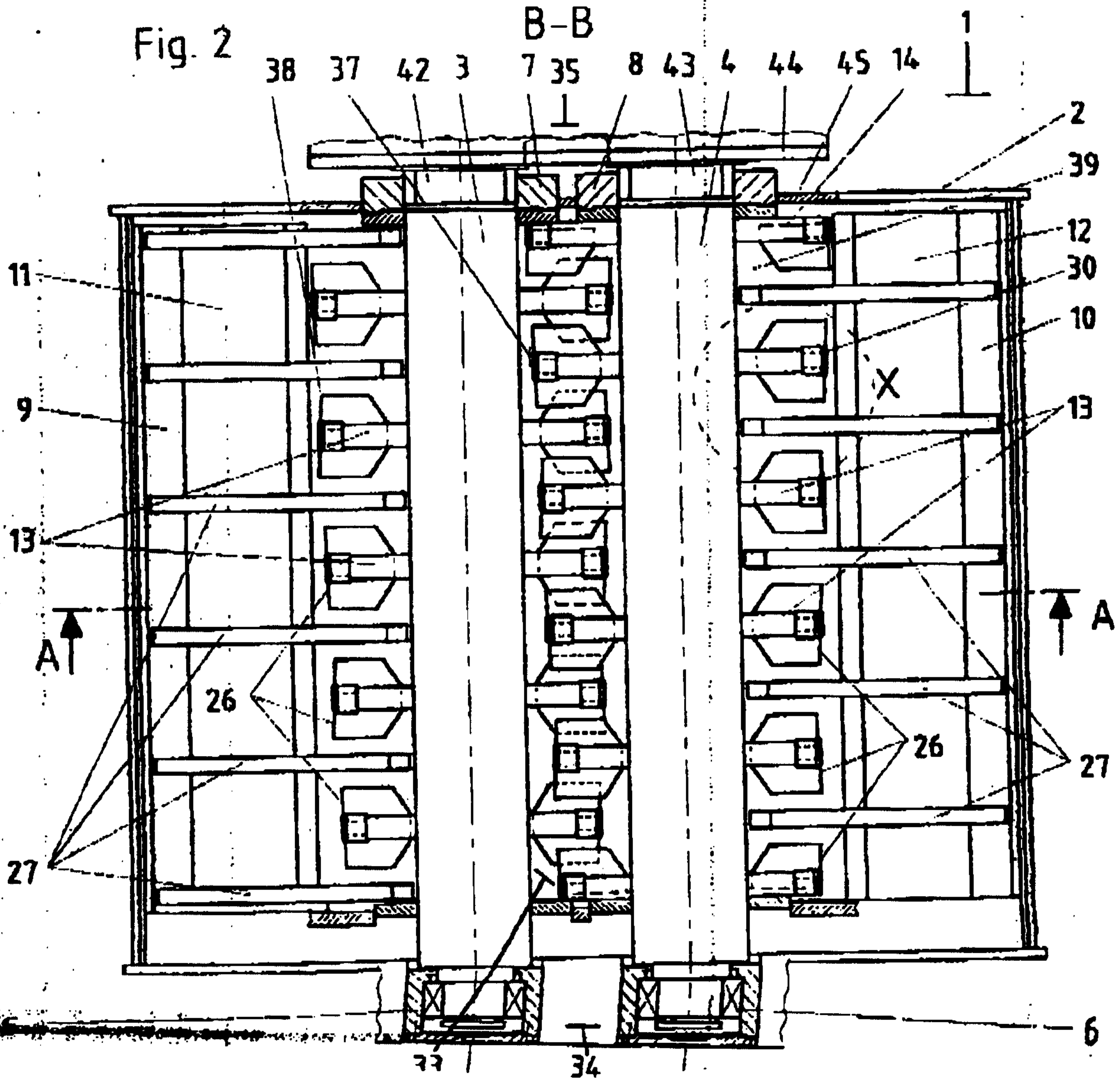

Fig. 2

B-B



Werkzeug

Tool

4teilig

4-part

Fig. 3

Fig. 4

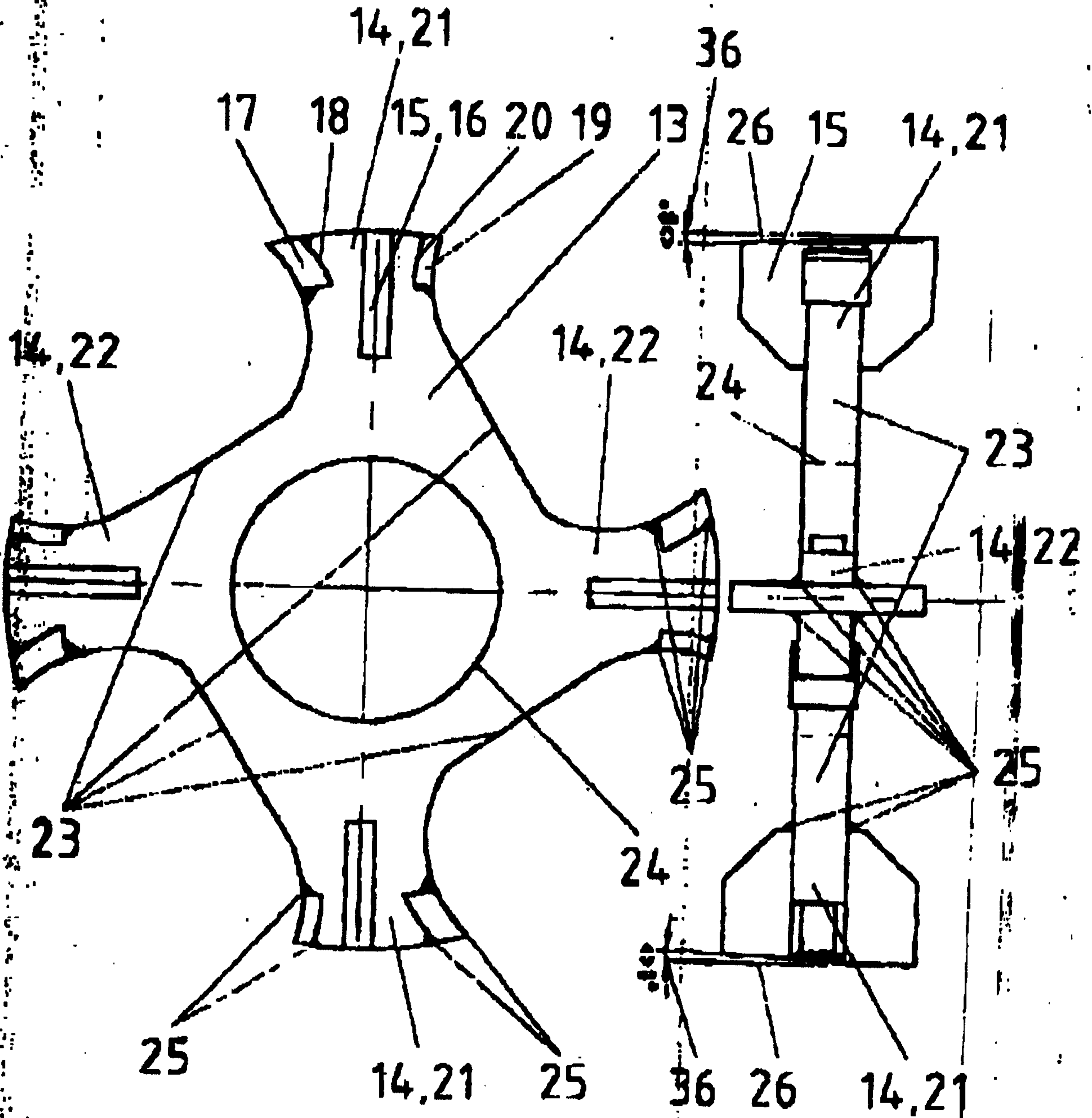

Fig. 5

Werkzeugträger

Tool Carrier

4teilig - 4-part

konstant variabel constant variable

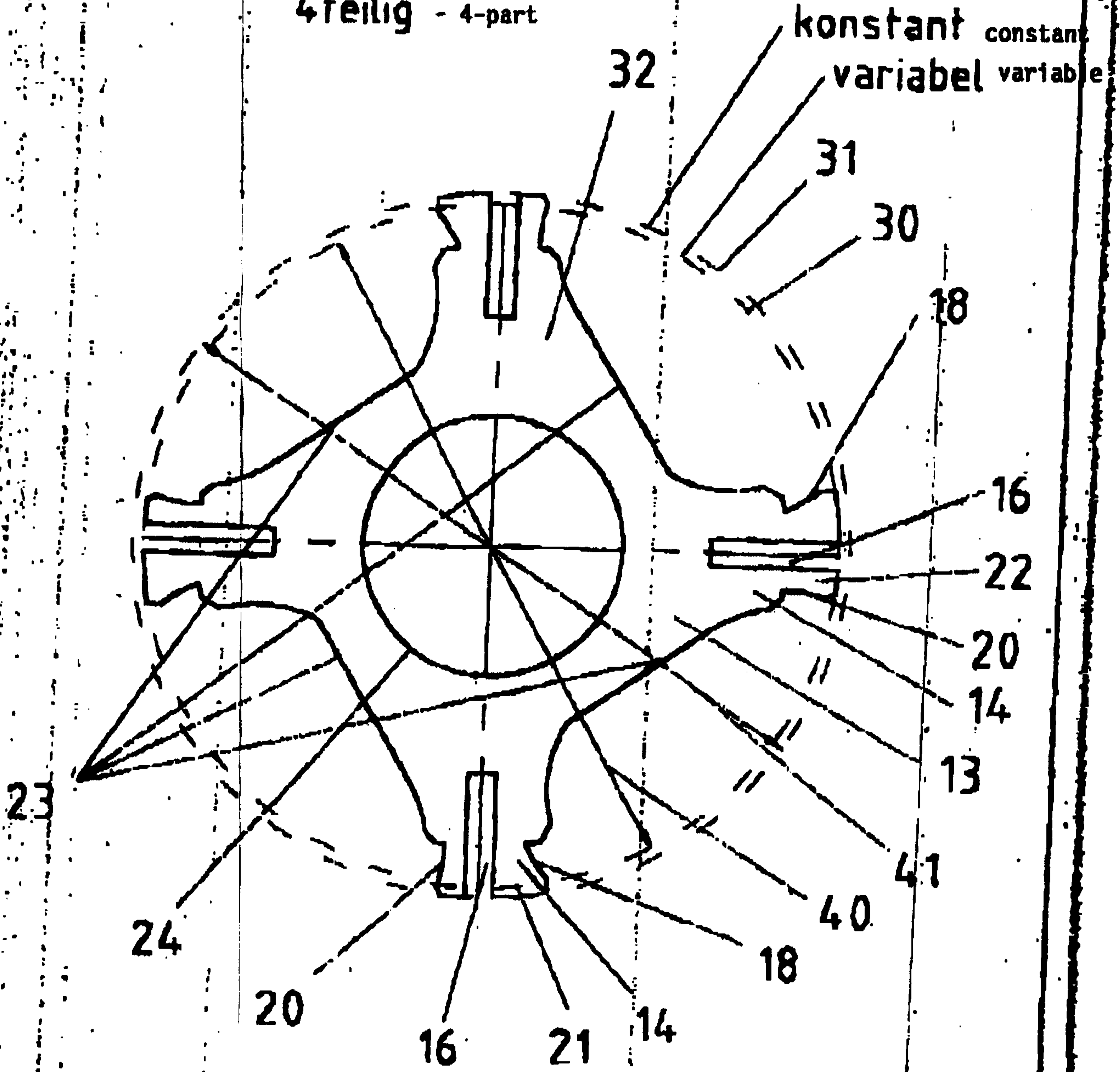

Fig. 6
Einzelheit X

DETAIL X

