

(19) World Intellectual Property Organization
International Bureau



(43) International Publication Date
26 April 2001 (26.04.2001)

PCT

(10) International Publication Number
WO 01/30088 A1

- (51) International Patent Classification⁷: H04N 9/82 Hendrik, G.; Prof. Holstlaan 6, NL-5656 AA Eindhoven (NL).
- (21) International Application Number: PCT/EP00/09951
- (22) International Filing Date: 9 October 2000 (09.10.2000)
- (25) Filing Language: English
- (26) Publication Language: English
- (30) Priority Data: 99203454.6 21 October 1999 (21.10.1999) EP
- (71) Applicant: KONINKLIJKE PHILIPS ELECTRONICS N.V. [NL/NL]; Groenewoudseweg 1, NL-5621 BA Eindhoven (NL).
- (72) Inventors: WILSON, Patricia, E., M.; Prof. Holstlaan 6, NL-5656 AA Eindhoven (NL). RAMASUBRAMANIAM, Kousik, S.; Prof. Holstlaan 6, NL-5656 AA Eindhoven (NL). THIJSSEN, Paulus, T., A.; Prof. Holstlaan 6, NL-5656 AA Eindhoven (NL). TILLEMA,
- (74) Agent: DE JONG, Durk, J.; Internationaal Octrooibureau B.V., Prof Holstlaan 6, NL-5656 AA Eindhoven (NL).
- (81) Designated States (national): CN, ID, IN, JP, KR, SG, VN.
- (84) Designated States (regional): European patent (AT, BE, CH, CY, DE, DK, ES, FI, FR, GB, GR, IE, IT, LU, MC, NL, PT, SE).
- Published:
 - With international search report.
 - Before the expiration of the time limit for amending the claims and to be republished in the event of receipt of amendments.

For two-letter codes and other abbreviations, refer to the "Guidance Notes on Codes and Abbreviations" appearing at the beginning of each regular issue of the PCT Gazette.

(54) Title: PLAYBACK APPARATUS AND METHOD FOR PLAYBACK OF A RECORD CARRIER

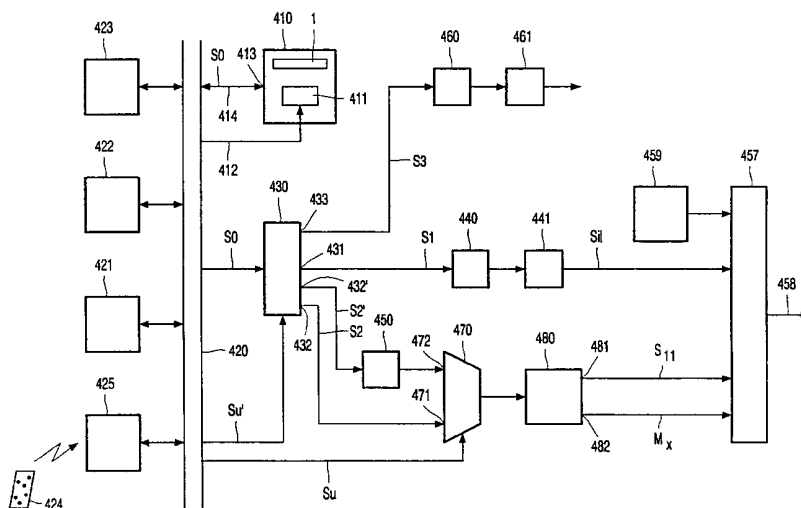

(57) Abstract: A playback apparatus of the invention comprises reading means (410) for reading an information stream (S0) from a record carrier (1) and demultiplexing means (430) for separating at least a first and a second sub-stream (S1, S2) from the information stream (S0), which first sub-stream (S1) comprises encoded video data and which second sub-stream (S2) comprises graphics data. The apparatus further comprises first decoding means (441) for decoding the first sub-stream (S1) and second decoding means (480) for receiving the second sub-stream (S2) and for decoding graphics data encoded according to a first format (DVD Video sub-picture format). The apparatus further comprises combining means (457) for combining the decoded video stream (S11) and the decoded graphics data (S21). The apparatus is characterized by converting means (450) for receiving a second sub-stream (S2) of graphics data encoded according to a second format (SVCD OGT-format) and characterized by selecting means (470) for selecting the converted graphics data or the data according to the first format from the second stream as input data for the second decoding means.

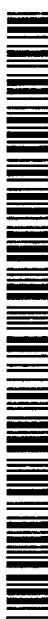

WO 01/30088 A1

Playback apparatus and method for playback of a record carrier.

The invention relates to a playback apparatus for playback of a record carrier, the apparatus comprising

- reading means for reading an information stream from the record carrier,
- demultiplexing means for separating at least a first and a second sub-stream, 5 from the information stream, which first sub-stream comprises encoded video data and which second sub-stream comprises encoded graphics data,
- first decoding means for decoding the first sub-stream,
- second decoding means for receiving the second sub-stream and for decoding graphics data encoded according to a first format, according to which first format the graphics 10 data comprise a header including information about the size of the graphics data and an address of a command table, the graphics data further data assigning a pixel value to each of a set of pixels, the pixel value referring to a color code which refers to an entry in a color lookup table, the command table comprising one or more graphics commands for controlling display of the graphics data,
- 15 - combining means for combining the decoded stream of video data and the decoded stream of graphics data.

The invention further relates to a method for playing back a record carrier.

- 20 From EP 0 849 681 A1 an apparatus is known comprising second decoding means in the form of a sub-picture decoding unit for decoding sub-picture units of a record carrier according to the DVD Video standard. Such a sub-picture unit (SPU) comprises a header, data assigning a pixel value to each of a set of pixels, which data may be run length encoded and a sequence of display control commands. The sub-picture decoding unit 25 comprises a memory for storing a first and a second sub-picture unit, i.e. one that is currently being displayed and one that is about to be displayed. Further it comprises a first decoding unit for processing display control commands, a run length decoding unit for decoding the run length encoded data into a bitmap, and a sub-picture unit for generating the actual sub-picture. Combining means combine the generated sequence of sub-pictures with a video data stream

from a video decoder so as to obtain a composite video stream. In addition to the first and the second sub-stream the record carrier for reproduction by the playback apparatus may contain further sub-streams, e.g. further sub-streams comprising graphics data or audio data.

The SVCD standard version 1.0 describes record carriers which comprise video
5 and overlay graphics data. In this standard the graphics data complies with a second format. The overlay graphics data is stored in so called overlay graphics and text pages (OGT-pages). An OGT-page comprises a header, color lookup table data, and may also comprise pixel data. The latter should be run length encoded, but according to other compression rules than those
10 runlength encoded data assign a color code to each pixel of the OGT-page, which color code directly refers to an entry of a color lookup table. On the contrary in the subpicture format of DVD-video the pixels are assigned a pixel value, which refers to a color code, which on its turn refers to an entry in a color lookup table. The known apparatus is not suitable for reproducing a record carrier according to the SVCD standard.

15

It is an object of the invention to provide an apparatus of the kind described in the introduction which is both capable of reproducing a record carrier according to the DVD Video standard and according to the SVCD standard. According to the invention the apparatus
20 is characterized in that it further comprises

- converting means for receiving a second sub-stream of graphics data encoded according to a second format and converting said graphics data from the second format into the first format, according to which second format the graphics data comprise a header which includes information about the size of the graphics data and flags indicating whether the
25 graphics data further comprises
a first color lookup table and information defining a first area, and/or
a second color lookup table and information defining a second area, and/or
a third color lookup table and information defining a third area, and/or
a set of run length encoded data assigning a color code to each of a set of pixels, the color code
30 referring to an entry in a color lookup table, the second color lookup table being applied within the second area, the third color lookup table being applied within the third area, the first color lookup table being applied in those portions of the first area not coinciding with the second or the third area, and

- selecting means for selecting the converted graphics data or the data according to the first format from the second stream as input data for the second decoding means.

The flags of an OGT-page indicate whether optional components of the page are present, such as runlength encoded data or CLUT_DATA, i.e. a color lookup table and an area corresponding therewith. If a flag indicates that a component is lacking the OGT-page to be displayed is reconstructed on the basis from a corresponding component loaded earlier. For example if the OGT-page to be displayed only comprises CLUT DATA as an optional component, then the already loaded runlength encoded data is applied.

As the conversion means convert the OGT-graphics stream into a sub-picture stream the sub-picture decoding unit of the apparatus of the invention is both used for reproducing sub-picture data from a DVD Video disk and for reproducing overlay graphics and text data from an SVCD-disk. Separate decoding means for reproducing a graphics image from a second sub-stream which is encoded according to the second graphics format therewith are superfluous.

15

These and other aspects of the invention are described in more detail with reference to the drawing. Therein,

Figure 1 schematically shows a playback apparatus according to the invention,

Figure 2 schematically illustrates the first graphics format,

Figure 3 illustrates the meaning of pixel values in the first graphics format,

Figure 4 illustrates runlength code words in the first graphics format,

Figure 5 illustrates the second graphics format,

Figure 6 schematically shows the operation of the conversion means,

Figure 6A shows an aspect of the operation in more detail,

Figure 6B shows another aspect of the operation in more detail,

Figure 7 shows a template for a command table,

Figure 8 illustrates the conversion of runlength encoded data complying with the second format into runlength encoded data complying with the first format,

Figure 9 shows an example of a color lookup table complying with the second format,

Figure 10 shows a portion of a color lookup table complying with the first format and corresponding to the color lookup table of Figure 9,

Figure 11 shows an example of a highlight area as defined in the second format,

Figure 12 shows a portion of a command table defined in the first graphics format corresponding to the data shown in Figures 9 and 11,

Figure 13 shows a part of the playback apparatus in more detail.

5

Figure 1 shows a playback apparatus suitable for playback of a record carrier 1. The apparatus comprises reading means 410 for reading an information stream S0 from the record carrier 1. The reading means 410 are provided with control means 411 to control the reading of the information stream S0 from the record carrier 1 upon instructions by address
10 signals 412 from a central processing unit 421. An output 413 of the reading means 410 is coupled to a system bus 420 of a customary computer system for delivering the read information stream S0 over a data signal path 414. The apparatus further comprises demultiplexing means 430 for separating at least a first S1 and a second sub-stream S2 from the information stream S0 at respectively a first output 431 and a second output 432. The
15 demultiplexing means 430 is controlled by a control signal Su' generated by the central processing unit 421. The first sub-stream S1 comprises encoded video data. The video data S1 preferably is MPEG encoded. The second sub-stream S2 comprises graphics data. The demultiplexer 430 also separates a third sub-stream S3 at output 433 from the information stream which comprises audio data. The output 433 is coupled via an input buffer 460 to audio
20 decoding means 461.

The apparatus shown in Figure 1 comprises first decoding means 441 for decoding the first sub-stream S1. The first decoding means 441 are coupled to the output 431 of the demultiplexer 430 via an input buffer 440. The apparatus further comprises second decoding means 480 for decoding graphics data encoded according to a first format. The
25 second decoding means 480 may be integrated with other means, such as for example the first decoding means 441 and the audio decoding means 461. In a practical embodiment those means are implemented in an integrated circuit such as the STi 5505. The decoded stream of video data S11 and the decoded stream of graphics data S21 are combined by combining means 457. The second decoding means 480 not only generate decoded graphics data S21, but
30 also generate a mixing control signal Mx for determining how the decoded stream of graphics data is combined with the decoded stream of video data.

The graphics data encoded according to the first format, which are schematically shown in Figure 2, comprise a header (SPUH) including information about the size (SPU_SZ) of the graphics data and an address (SP_DCSQT_SA) of a command table

(SP_DCSQT). The graphics data further comprises data (PXD) assigning a pixel value to each of a set of pixels. The pixel value refers to a contrast code and to a color code. The latter refers on its turn to an entry in a color lookup table (PGC_SP_PLT) and refers to a contrast value. The data PXD may be run length encoded. The contrast value defines how the stream of decoded graphics data and the stream of decoded video data are to be combined. The command table (SP_DCSQT) comprises one or more commands for controlling display of the graphics data. The command SET_CONTR defines which contrast values are assigned to the pixel values. The command SET_COLOR defines which color codes are assigned to the pixel values. The first format is prescribed in the DVD Video standard for the so-called sub picture units.

Each pixel in the line is coded as 2 bits. The meaning thereof is shown in Figure 3. For example, if the value is 00 then the set color command and set contrast command for Background Pixels are applied. The color lookup table PGC_SP_PLT does not make part of the sub-picture unit, but is contained in a file called VTSI (video title set information) once for a sub-picture stream.

The assigned pixel data can be run length encoded according to 7 compression rules. Figure 4 shows five of these compression rules which assign code words to sequences of pixels having the same pixel value p_1, p_2 . The sequences respectively have a length in the range of $N_{pix} = 1-3, 4-15, 16-63$ and $64-255$ pixels. $N_{pix} = EOL$ indicates a sequence of pixels having the same pixel value until the end of the line. Therein n_1, \dots, n_8 represent the number of pixels. n_1 is the most significant bit.

Two other compression rules prescribe that

- If necessary four zero bits are added as stuffing bits for byte alignment at the end of each line.
- The size of the run-length coded data within one line shall be 1440 bits or less.

The command table (SP_DCSQT) in the graphics data may comprise the following commands.

STA_DSP starts the display of the SPU. It may be overwritten by the OFF display state of the SP.

SET_COLOUR assigns a color code to each pixel value. This command requires a parameter with 4 fields i.e.

- one to set the color code for the background pixels (bits 0 to 3)
- one to set the color code for the pattern pixels (bits 4 to 7)
- one to set the color code for the emphasis pixels -1 (bits 8 to 11)

- one to set the color code for the emphasis pixels -2 (bits 12 to 15)

SET_CONTR sets the mixture ratio between each pixel of the sub-picture and of the main picture. The contrast is set in a similar way as is the case with the **SET_COLOUR** command, i.e. if the parameter to **SET_CONTR** is:

5	0xF	0x1	0xA	0x4
---	-----	-----	-----	-----

Then a mixture ratio is 0x4 is assigned to the pixel data 00, a mixture ratio 0xF pixel data is 11 etc. DVD Video allows a contrast in the range of 0 to 15 for each of the four colors. The **SET_CONTR** field is used to define this.

- 10 **SET_DAREA** defines a rectangular area in which the pixel data is displayed.

If this command is not given for a particular SPU then the previous settings are used.

CHG_COLCON changes the color and contrast of pixel data during display of a video frame. The first byte of the parameter gives the command code i.e. 0x7. The second and third bytes give the length of the parameter. These bytes are followed by the Pixel Control Data (PXCD).

- 15 The latter consists of a number of Line Control Informations (LN_CTLI). This structure gives the line numbers of the rectangular highlight areas (start line number, end line number) plus the number of Pixel Control Informations (PX_CTLI) that follow. There can be up to 8 PX_CTLIs e.g.

- If there is only 1 then this PX_CTLI defines the left-hand side co-ordinates of the
20 rectangle. The end of the line defines the right hand side.
- If there are 2 PX_CTLIs then the first defines the co-ordinates of the left-hand side of the rectangle. The second PX_CTLI defines the co-ordinates of the right-hand side.
- Pixel Control Data comprising 3 PX_CTLI correspond to 2 rectangular areas instead of one, which areas are placed side by side and of even height.
- Etc.

Note that according to the DVD Video standard the minimum width (i.e. difference between 2 start pixel numbers) is 8.

Pixel Control Information comprises the following data.

- The start pixel number (X co-ordinate).
- The color codes for over ruling the values set by **SET_COLOUR**.
- The contrasts for over ruling the values set by **SET_CONTR**.

The apparatus according to the invention comprises converting means 450 for converting the graphics data from a second format into the first format. The apparatus further comprises selecting means 470 to select either the converted graphics data or the data

according to the first format from the second stream as input data for the second decoding means 480. According to the second format, shown in Figure 5, the graphics data comprise a header (HEADER) which includes information about the size of the graphics data and flags (page_flag, highlight_1_flag, highlight_2_flag, display_data_flag) indicating whether the graphics data further comprises color lookup table data (CLUT DATA) comprising a first color lookup table (CLUT_data) and information about a first area (page_area()), and/or a second color lookup table (CLUT_1_data) and information about a second area (highlight_1_area()), and/or a third color lookup table (CLUT_2_data) and information about a third area (highlight_2_area()), and/or a set of run length encoded data (display_data) assigning a color code to each of a set of pixels. The second and the third color lookup table respectively are applied within the second area and the third area. The first color lookup table is valid in those portions of the first area not coinciding with the second or the third area. Such a second format, as shown in Figure 5, is known from the Super Video CD Specification, version 1.0 in the form of a OGT-page (Overlay Graphics and Text Page).

In the embodiment described, the CPU 421 also forms means to detect whether the record carrier comprises graphics data according to the first or according to the second format. If it is detected that the record carrier is a DVD Video disk, which implies that the record carrier 1 comprises graphics data according to the first format, the central processing unit 421 renders a signal Su with a first logical value, achieving therewith that the selecting means 470 selects the signal at its first input 471 as its input signal and delivers this signal to the second decoding means 480. The second decoding means 480 generate decoded graphics data in the form of a bitmap at a first output 481 and a mixing control signal at a second output 482. If it is detected that the record carrier 1 is a SVCD disk, which comprises graphics data according to the second format, the central processing unit 421 renders a signal Su with a second logical value, achieving therewith that the multiplexer 470 selects the signal at its second input 472 as its input signal and delivers this signal to the second decoding means 480. The signal at the second input is generated by the converting means 450. The converting means 450 convert the stream of graphics data at the output 432' of the demultiplexer 430 from the second format into the first format.

In the embodiment described here the first format is the DVD Video sub-picture format and the second format is the SVCD Overlay Graphics and Text format.

The operation of the converting means is schematically shown in Figure 6. In a first program portion denoted as P1 a first OGT page, a so-called OGT base page is read into a memory. An OGT base page comprises at least display data and color lookup table data corresponding thereto. Next, in a second program portion P2 the information in the OGT base page is converted into corresponding information complying with the first format. Program portion P2 is described in more detail with reference to Figure 6A. In program portion P3 a next OGT page is read. In program portion P4 it is decided whether this page is an OGT base page or an OGT update page. An OGT update page does not contain display data but only CLUT_DATA, for example information about a modified highlight area. If the page is an OGT base page, a sub picture unit is created in program portion P5 on the basis of the information earlier converted and in program portion P6 the so created sub picture unit is sent to the sub picture decoder. The program then continues with program portion P2 to convert the OGT base page read in program portion P3. If the page is an OGT update page it is determined in program portion P7 how much time is available before the earliest time stamp in the command table of the subpicture unit to be created will expire. If the time is available is insufficient for finishing the computations necessary to combine the information read in program portion P3 with the already converted information then a SPU is constructed on the basis of the already converted information in program portion P10 and this SPU is written to the SPU decoder in program portion P11. Subsequently in program portion P9, described in more detail with reference to program portion 6B, the information of the update page is combined with the information already converted. In that case any color lookuptable data only relevant to pages preceding the present update page may be overwritten. If in program portion P7 it is determined that the time available is sufficient for finishing the computations, it is determined in program portion P8 whether the color lookup table PGC_SP_PLT of the subpicture unit which is computed still comprises sufficient space to include the color lookup table data of the last OGT update page. If this is not the case then the program continues with program portion P10. If sufficient space is available then the program continues with program portion P9.

Next, program portion P2 is described in more detail with reference to Figure 6A. In the first program portion P2-1 thereof a template shown in Figure 7 is constructed for the start of the command table SP_DCSQT of the sub picture unit which is to be calculated. The template contains some parameters which are to be determined during processing the subpicture unit. These are the start address <SA> of the next table, which can be determined as soon as the present table is completed. The color code <CC> and the contrast <CT> have to be

derived from the color lookup table data of the OGT base page. The value <DA> is derived from the parameters defining the page area. The address <BF> of the first pixel of the Bottom Field can be determined after the display_data in the OGT-page has been runlength decoded. Runlength decoding takes place in program portion P2-2. In program portion P2-3 it is
5 determined whether the value of page_data_length comprised in the header of the OGT-page is less than a predetermined value. If that is the case the decoded data is runlength encoded according to the first format. In the present embodiment, where the second format is the SVCD format for Overlay Graphics and Text, the run length encoded data comprises 7
10 different code words. These are converted into the run length code used in the first format as shown in Figure 8.

It is not necessary to fully complete the program portion P2-2 before the program portion P2-4 is executed. These program portions P2-2, P2-4 may for example be implemented as parallel processes which operate on the run length encoded data in a pipelined
manner.

15 In program portion P2-5 the color lookup table data of the color lookup table of the OGT page is loaded in the color lookup table PGC_SP_PLT of the sub picture unit which is created.

In program portion P2-6 the values <CC> and <CT> are derived from the color lookup table data.

20 In program portion P2-7 the number of entries of the PGC_SP_PLT is set to 4.

The representation of colors in the second format, the SVCD overlay graphics format, differs significantly from that in the first format, the DVD Video sub-picture format.

25 In the first place, in the second graphics format a graphics stream may contain a plurality of overlay graphics pages, which each contain a different color lookup table comprising 4 possible colors and transparency values for the page area. Furthermore, each page may contain one or two additional color lookup tables which define color and transparency values in the highlight areas. The color lookup tables may change from page to
30 page. Hence, a maximum of 12 (4 for the page area, 4 for highlight area 1 and 4 for highlight area 2) colors can be defined per OGT page. Contrary thereto, in the sub-picture format of DVD Video, only one CLUT per Program Chain per VTS (e.g. one program stream) may be defined. Furthermore in an OGT-page the runlength encoded data represents a color code which is an index to one of the color lookup tables, dependent on whether a pixel is within

highlight_1_area, highlight_2_area, or outside both areas. In a subpixel unit the runlength encoded data assigns a pixel value which refers to an index of a color lookup table PGC_SP_PLT via a color code. The color code is assigned with SET_COLOR and/or CHG_COLCON commands.

5 The CLUT in the second graphics format includes in addition to a Y, a Cb and a Cr value, a mix-ratio. The mix-ratio specifies the level of blending of the decoded overlay graphics data (OGT_output) with the decoded video data (video_output). The following blending formula applies:

$$10 \quad \text{display output} = (\text{mix_ratio}/255)*\text{OGT_output} + ((255 - \text{mix_ratio})/255)*\text{video_output}.$$

In the first graphics format, the DVD Video sub-picture format, a mix_ratio can be defined with the command SET_CONTR. In the second graphics format, overlay graphics and text, OGT, a contrast value up to 255 can be used while in SPU the value of the mix_ratio is limited to a range from 0 to 16. In the first graphics format the display output is calculated from the output (sub_picture_output) of the second decoding means 480 and the output of the first decoding means 441 (video output) as

$$15 \quad \text{display output} = (k/16)*\text{sub_picture_output} + ((16-k)/k)*\text{video_output},$$

wherein

$$k = \text{contrast for contrast} = 0 \text{ and } k = \text{contrast} + 1 \text{ for contrast} > 0.$$

20 The contrast is preferably calculated from the mix_ratio as follows.

$$\text{contrast} = \text{mix_ratio}/16$$

By way of example a conversion of color lookup table information complying with the second format as shown in Figure 9 into the first data structure is given. In Figure 9 the address is indicated as sector number: byte offset: bit offset. The bit with offset 0 is the most significant bit.

25 The color information (Y_value[], Cb_value[], Cr_value[]) in Figure 9 is converted into a PGC_SP_PLT for the graphics data complying with the first format as shown in Figure 10. The PGC_SP_PLT makes part of the Video Title Set Information (VTSI).

30 The mix_ratio in a CLUT of the graphics data according to the second format is converted in a contrast by means of the command CHG_COLCON as set out below.

In program step P2-8 it is determined whether the OGT page comprises a first highlight area. If this is the case, the color lookup table entries defined in the color lookup table for said area are added to the color lookup table PGC_SP_PLT in program portion P2-9. Subsequently in program portion P2-10, parameters are added to the CHG_COLCON

command to represent the color codes referring to those entries. In the program portion further parameters are added to represent contrast values applicable in the first highlight_area.

If it is determined in program step P2-12 that the OGT-page comprises a second highlight area, than program steps P13 to P15 are performed. These programsteps correspond
5 to the programsteps P2-9 to P2-11.

After a conversion from the second into the first format, the highlight areas are represented as a 10-byte parameter to the CHG_COLCON command. The parameter comprises

4 bytes for Line Control Information (LN_CTLI) i.e.

- 10 • start line number of the highlight area within the subpicture
- number of changes
- end line number of the highlight area within the subpicture

and 6 bytes of Pixel Control Information (PX_CTLI) i.e.

- start pixel number on the lines in the range defined by start- and end line number
- 15 • new color code
- new contrast code

The state of the end of the highlight is defined by another six byte of pixel control information. This additional information is not necessary if the highlight area is to extend until the end of a line. A restriction is that for a given time frame, i.e. a time interval
20 within two time stamps of the command table, only one CHG_COLCON command may be given. Furthermore, within a CHG_COLCON, a maximum of 8 changes can be defined.

A single highlight area is translated into a CHG_COLCON command with 1 Line Control Information giving the co-ordinates (line numbers) of the area and 2 Pixel Control Informations, one for the starting position and one for the ending position of the area.
25 However, for a single highlight area extending until the right border of the subpicture unit one instead of two Pixel Control Informations suffices.

Two highlight areas result in a CHG_COLCON command with 2 Line Control Informations. Each Line Control Information would have two Pixel Control Informations (as above). The only limitation is that the minimum width of a highlight area is 8 pixels.

30 A Karaoke mode of the apparatus according to the invention may be realized by multiple CHG_COLCON commands, each at a different video frame, as described above.

An OGT page has for example a highlight area as defined in Figure 11. In an embodiment of the apparatus according to the invention the conversion means convert these information as shown in Figure 12.

Figure 6B shows the program portion P9 of Figure 6 in more detail. In this program portion P9 it is first determined in program portion P9-1 whether a color (Y, Cb, Cr) in a clut entry of the present OGT-page already occurs in the PGC_SP_PLT of the sub pixel unit which is being composed. If it does occur, a reference to that entry is added as a
5 parameter to a CHG_COLCON command in program step P9-2. If it does not occur a new reference to an entry is assigned in program portion P9-3. Next the color is copied to the entry of the PGC_SP_PLT with that reference in program portion P9-4. Subsequently in program portion P9-5 the number of entries used in the PGC_SP_PLT is increased with 1. The program portion P9-2 is executed.

10 Figure 13 shows an embodiment of the conversion means in more detail. The conversion means 450 shown comprise a microprocessor 451, memory means 452 for storing graphics data according to the second format, memory means 454 for storing a lookup table, and comparing means 453 for comparing the stored color lookup table and a new lookup table contained in the graphics data encoded according to the second format. It was noted that
15 replacing the program chain sub-picture pallet PGC_SP_PLT may result in a disturbing flashing of the image which is generated. It has been found by the inventors that this phenomenon may be substantially reduced in this embodiment of the apparatus according to the invention. The comparing means 453 achieve that the data in the stored color lookup table is replaced and that the data of the new lookup table is transmitted to the second decoding
20 means 480 if said data is not comprised in the stored lookup-table. In this way it is only necessary to replace the PGC_SP_PLT if the contents of the PGC_SP_PLT have to be changed.

It is remarked that the scope of protection of the invention is not restricted to the embodiments described herein. For example, while an embodiment of the apparatus
25 according to the invention is described which comprises detection means to detect which type of record carrier is present, an other embodiment comprises input means which enable a user to provide that information. The apparatus may comprise recording means for recording an information stream on the record carrier in addition to the reading means. Neither is the scope of protection restricted by the reference numerals included in the claims. The word
30 'comprising' does not exclude other parts than those mentioned in a claim. The word 'a(n)' preceding an element does not exclude a plurality of those elements. The invention further resides in each new feature or combination of features.

CLAIMS:

1. Playback apparatus for playback of a record carrier (1), the apparatus comprising
- reading means (410) for reading an information stream (S0) from the record carrier (1),
 - 5 - demultiplexing means (430) for separating at least a first and a second sub-stream (S1, S2) from the information stream (S0), which first sub-stream (S1) comprises encoded video data and which second sub-stream (S2) comprises encoded graphics data,
 - first decoding means (441) for decoding the first sub-stream (S1),
 - second decoding means (480) for receiving the second sub-stream (S2) and for
 - 10 decoding graphics data encoded according to a first format, according to which first format the graphics data comprise a header including information about the size of the graphics data and an address of a command table, the graphics data further comprising run length encoded data assigning a pixel value to each of a set of pixels, the pixel value referring to a color code which refers to an entry in a color lookup table, the command table comprising one or more
 - 15 graphics commands for controlling display of the graphics data,
 - combining means (457) for combining the decoded stream of video data (S11) and the decoded stream of graphics data (S21),characterized in that the apparatus further comprises
 - converting means (450) for receiving a second sub-stream (S2') of graphics data
 - 20 encoded according to a second format and converting said graphics data from the second format into the first format, according to which second format the graphics data comprise a header which includes information about the size of the graphics data and flags indicating whether the graphics data further comprises
 - a first color lookup table and information defining a first area, and/or
 - 25 a second color lookup table and information defining a second area, and/or
 - a third color lookup table and information defining a third area, and/or
 - a set of run length encoded data assigning a color code to each of a set of pixels, the color code referring to an entry in a color lookup table,

the second color lookup table being applied within the second area, the third color lookup table being applied within the third area, the first color lookup table being applied in those portions of the first area not coinciding with the second or the third area,

- selecting means (470) for selecting the converted graphics data or the data according to the first format from the second stream as input data for the second decoding means.

2. Playback apparatus according to claim 1, characterized in that the conversion means (450) comprise storing means (454) for storing a color lookup table, and comparing means (453) for comparing the stored color lookup table and a new lookup table contained in the graphics data encoded according to the second format, which comparing means achieve that the data in the stored color lookup table is replaced and the data of the new lookup table is transmitted to the second decoding means if said data is not comprised in the stored lookup-table

15

3. Playback apparatus according to claim 1 or 2, characterized by detection means (421) for detecting whether the record carrier (1) comprises graphics data encoded according to the first format or encoded to the second format.

20 4. Method for playing back a record carrier (1), according to which method
- an information stream (S0) is read from the record carrier (1),
- the information stream (S0) is separated in at least a first and a second sub-stream (S1, S2), which first sub-stream (S1) comprises encoded video data and which second sub-stream (S2) comprises encoded graphics data,

25 - the first sub-stream (S1) is decoded,
- in a first receiving mode a second sub-stream (S2) is received which comprises graphics data encoded according to a first format, according to which first format the graphics data comprise a header including information about the size of the graphics data and an address of a command table, the graphics data further comprising run length encoded data
30 assigning a pixel value to each of a set of pixels, the pixel value referring to a color code which refers to an entry in a color lookup table, the command table comprising one or more graphics commands for controlling display of the graphics data,
- the decoded stream of video data (S11) is combined with the decoded stream of graphics data (S21),

characterized in that

the method comprises a second receiving mode wherein a second sub-stream (S2) of graphics data is received which is encoded according to a second format, according to which second format the graphics data comprise a header which includes information about the size of the graphics data and flags indicating whether the graphics data further comprises

5 a first color lookup table and information defining a first area, and/or
a second color lookup table and information defining a second area, and/or
a third color lookup table and information defining a third area, and/or
a set of run length encoded data assigning a color code to each of a set of pixels, the color code

10 referring to an entry in a color lookup table,
the second color lookup table being applied within the second area, the third color lookup table being applied within the third area, the first color lookup table being applied in those portions of the first area not coinciding with the second or the third area,
in which second receiving mode the graphics data according to the second format is converted

15 into graphics data encoded according to the first format,
according to which method the converted graphics data or the data according to the first format from the second stream is selected to be decoded.

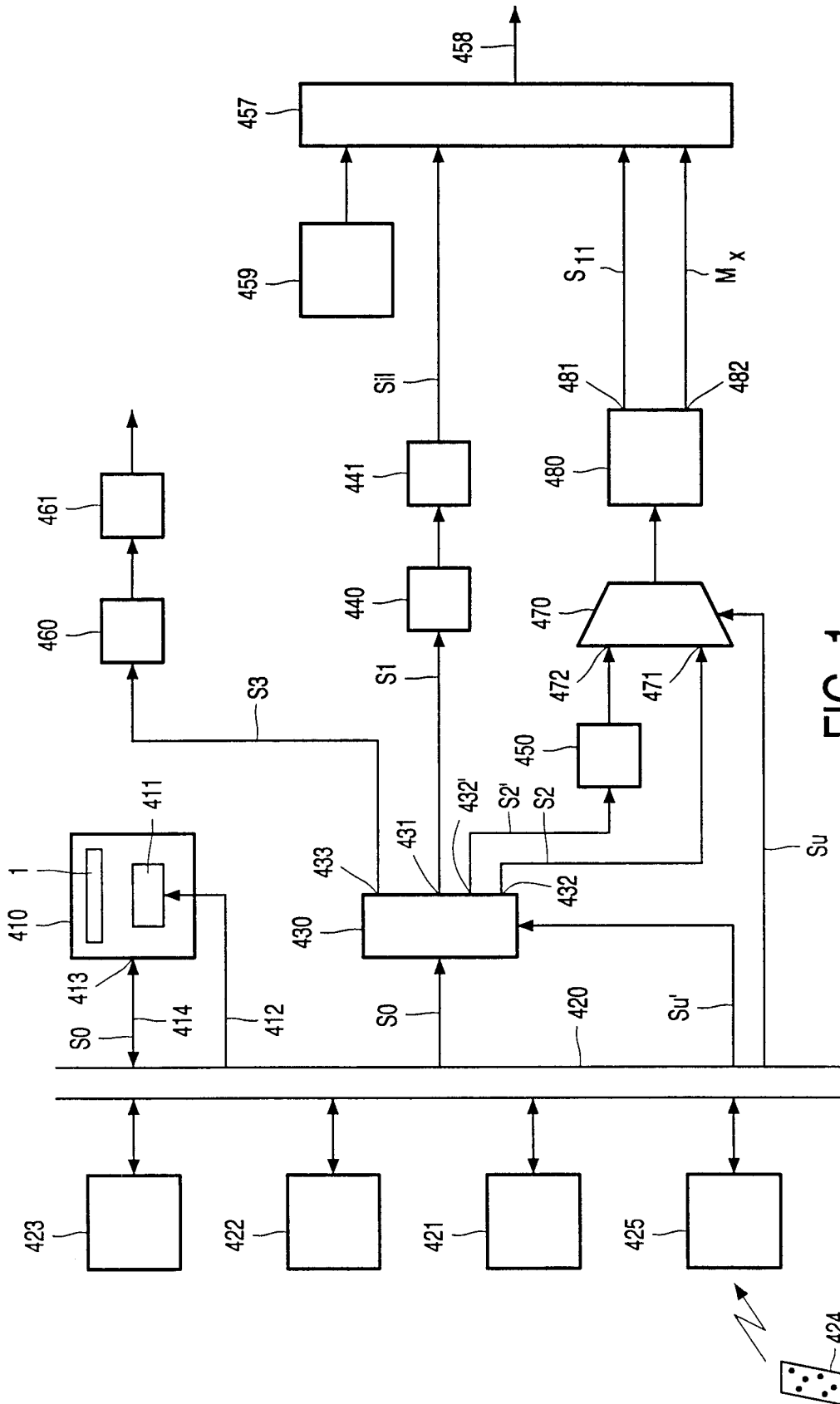

FIG. 1

2/10

first format
SPUH
PXD
SP_DCSQT

FIG. 2

Meaning of pixel values	
pixel name	pixel value
Background Pixel	0 0
Pattern Pixel	0 1
Emphasis pixel - 1	1 0
Emphasis pixel - 2	1 1

FIG. 3

Runlength code words assigned in the first graphics format																
Npix	Code word															
1 - 3	n ₁	n ₂	p ₁	p ₂	-	-	-	-	-	-	-	-	-	-	-	
4 - 15	0	0	n ₁	n ₂	n ₃	n ₄	p ₁	p ₂	-	-	-	-	-	-	-	
16 - 63	0	0	0	0	n ₁	n ₂	n ₃	n ₄	n ₅	n ₆	p ₁	p ₂	-	-	-	
64 - 255	0	0	0	0	0	0	n ₁	n ₂	n ₃	n ₄	n ₅	n ₆	n ₇	n ₈	p ₁	p ₂
EOL	0	0	0	0	0	0	0	0	0	0	0	0	0	0	p ₁	p ₂

FIG. 4

3/10

Second Format
Overlay _ graphics _ page ()
HEADER page _ data _ length CLUT _ type duration _ time _ flag page _ flag display _ data _ flag highlight _ 1 _ flag highlight _ 2 _ flag reserved if (duration _ time _ flag == 1) { duration _ time }
CLUT _ DATA if (page _ flag == 1) { page _ area () CLUT _ data () } if (highlight _ 1 _ flag == 1) { highlight _ 1 _ area () CLUT _ 1 _ data () } if (highlight _ 2 _ flag == 1) { highlight _ 2 _ area () CLUT _ 2 _ data () }
DISPLAY _ DATA if (display _ data _ flag == 1) { display _ data () } while (!longword _ aligned ()) { stuff _ byte } }

FIG. 5

4/10

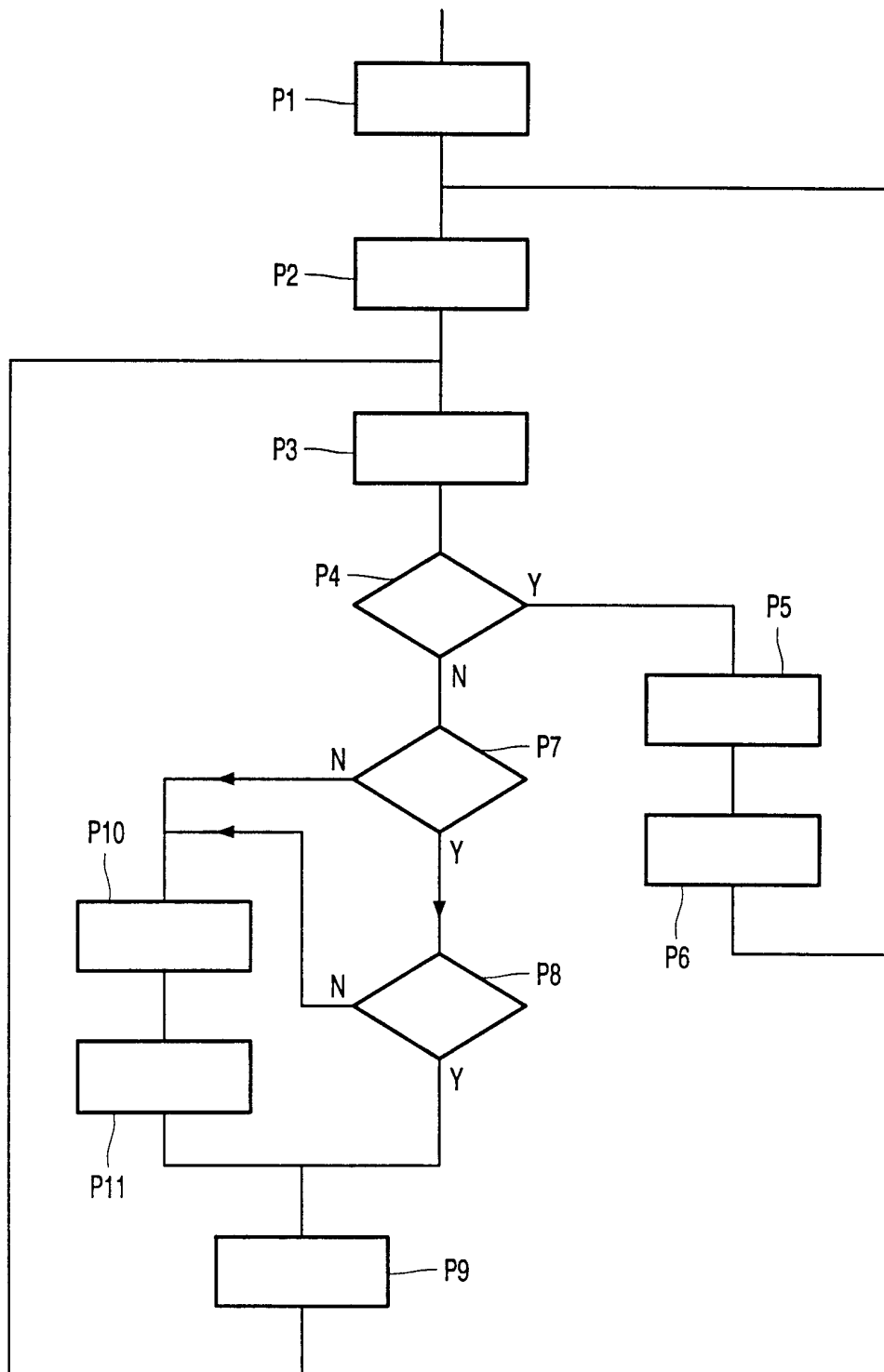

FIG. 6

5/10

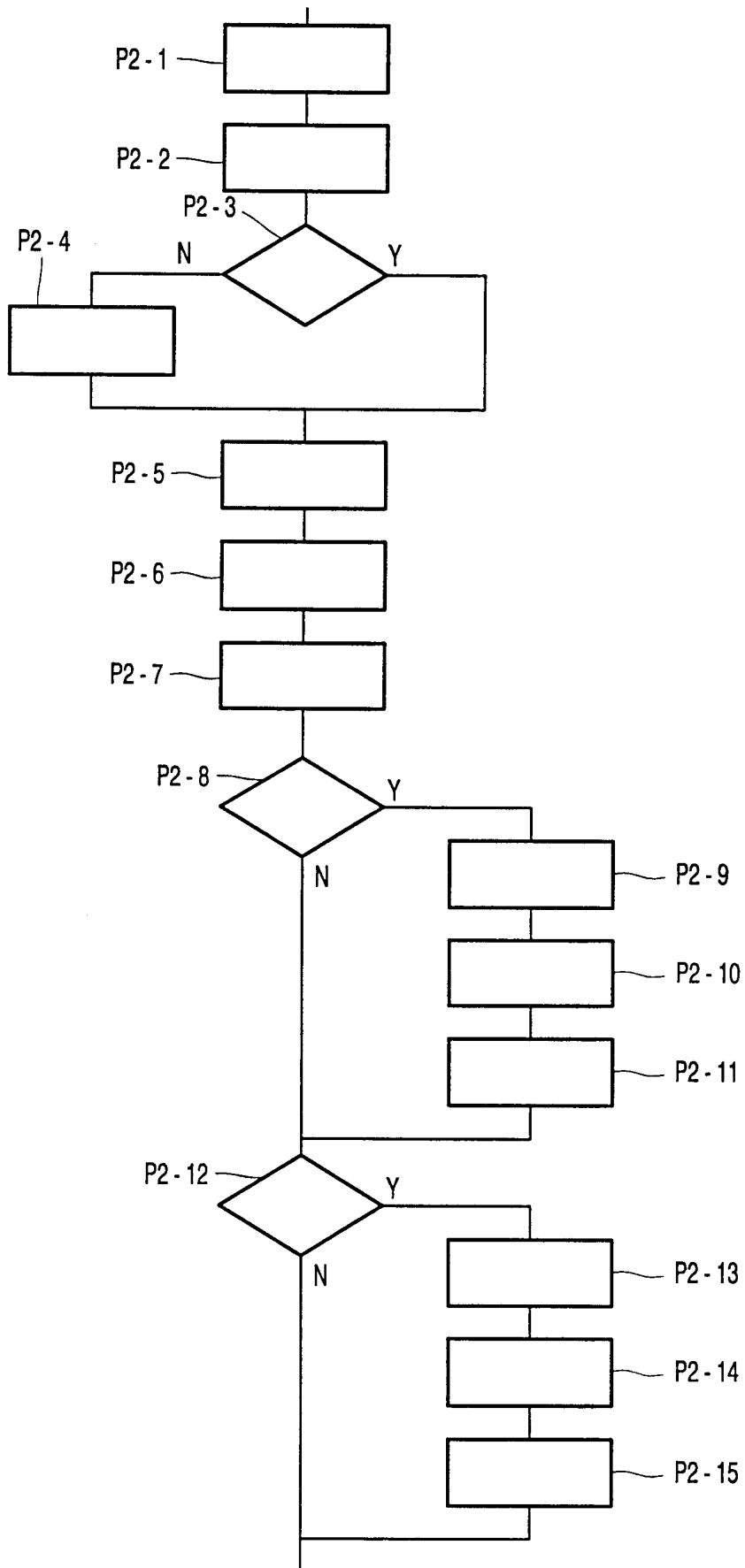

FIG. 6A

6/10

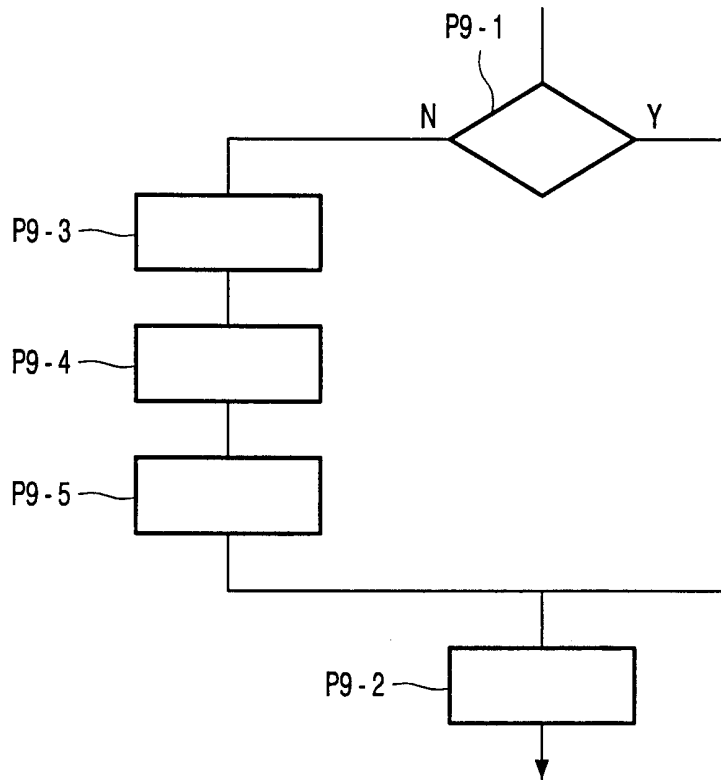

FIG. 6B

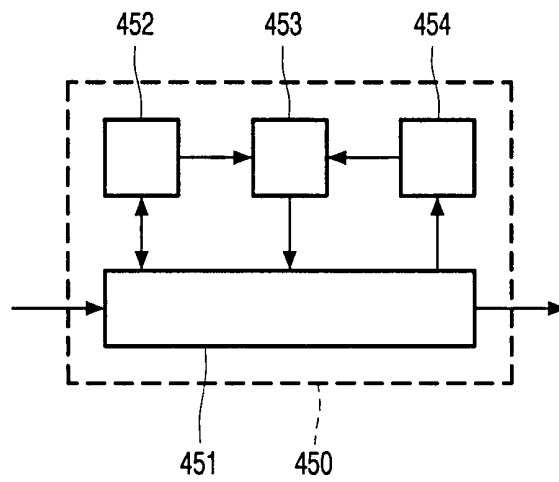

FIG. 13

7/10

Byte Position (s)	Value	Meaning	DVD field name
0..1	0 x 00 0 x 00	Start Execution Time	SP_DCSQ_STM
2..3	< SA >	Start Address of next table	SP_DCSQ_SA
4	0 x 00	Command to start display	STA_DSP
5	0 x 03	Command to set colour	SET_COLOUR
6	0 x < CC >	Color Code to set CLUT to	
7	0 x < CC >	Color Code to set CLUT to	
8	0 x 04	Command to set contrast	SET_CONSTR
9..10	< CT >	Contrast	
11..17	< DA >	Command to set Display Area	SET_DAREA
18	0 x 06	Command to set address of first fixels	SET_DSPXA
19..20	0 x 00 0 x 04	Address of first pixel of Top Field	
21..22	< BF >	Address of first pixel of Bottom Field	
23	0 x FF	End of Line control information	

FIG. 7

Conversion of run length encoded data		
2 nd Format	1 st Format	Meaning
01	01 01	01 (1 pixel)
10	01 10	10 (1 pixel)
11	01 11	11 (1 pixel)
00 00	01 00	00 (1 pixel)
00 01	10 00	00 00 (2 pixels)
00 10	11 00	00 00 00 (3 pixels)
00 11	01 00 00	00 00 00 00 (4 pixels)

FIG. 8

8/10

Example of CLUT in the second graphics format		
Address	Parameter	Value
0: 16 : 0	Y_value [0]	12
0: 17 : 0	Cb_value [0]	128
0: 18 : 0	Cr_value [0]	128
0: 19 : 0	mix_ratio [0]	0
0: 20 : 0	Y_value [1]	13
0: 21 : 0	Cb_value [1]	128
0: 22 : 0	Cr_value [1]	128
0: 23 : 0	mix_ratio [1]	255
0: 24 : 0	Y_value [2]	2
0: 25 : 0	Cb_value [2]	128
0: 26 : 0	Cr_value [2]	128
0: 27 : 0	mix_ratio [2]	255
0: 28 : 0	Y_value [3]	8
0: 29 : 0	Cb_value [3]	128
0: 30 : 0	Cr_value [3]	128
0: 31 : 0	mix_ratio [3]	255

FIG. 9

9/10

VTSI corresponding to the data shown Figure 8		
Address	Parameter	Value
0:164:0	PGC_SP_PLT [1]	
0:164:0	Reserved	0
0:165:0	Luminance_signal_Y	12
0:166:0	Color_difference_signal_Cr	128
0:167:0	Color_difference_signal_Cb	128
0:168:0	PGC_SP_PLT [2]	
0:168:0	Reserved	0
0:169:0	Luminance_signal_Y	13
0:170:0	Color_difference_signal_Cr	128
0:171:0	Color_difference_signal_Cb	128
0:172:0	PGC_SP_PLT [3]	
0:172:0	Reserved	0
0:173:0	Luminance_signal_Y	2
0:174:0	Color_difference_signal_Cr	128
0:175:0	Color_difference_signal_Cb	128
0:176:0	PGC_SP_PLT [4]	
0:176:0	Reserved	0
0:177:0	Luminance_signal_Y	8
0:178:0	Color_difference_signal_Cr	128
0:179:0	Color_difference_signal_Cb	128

FIG. 10

Example of a highlight area for an OGT page.		
Address	Parameter	Value
0:8:0	area_horizontal_start_position	170
0:10:0	area_vertical_start_position	4
0:12:0	area_width	260
0:14:0	area_height	24

FIG. 11

10/10

Conversion of the graphics data according to the second format		
Address	Command / Parameter	Value
0: 3423 : 0	SP_DCCMD Code \$07 (CHG_COLCON)	
0: 3424 : 0	Extended field size	14
0: 3426 : 0	LN_CTLI 0	
0: 3426 : 0	Reserved	\$ 00
0: 3426 : 6	Change start line nr.	170
0: 3428 : 0	Number_of_changes	1
0: 3428 : 4	Reserved	\$ 00
0: 3428 : 6	Change termination line nr.	193
0: 3430 : 0	PX_CTLI 0	
0: 3430 : 0	Reserved	\$ 00
0: 3430 : 6	Change start pixel	4
0: 3432 : 0	New emphasis pixel - 2 color_code	3
0: 3432 : 4	New emphasis pixel - 1 color_code	2
0: 3433 : 0	New pattern pixel color_code	4
0: 3433 : 4	New background pixel color_code	0
0: 3434 : 0	New emphasis pixel - 2 contrast	15
0: 3434 : 4	New emphasis pixel - 1 contrast	15
0: 3435 : 0	New pattern pixel contrast	15
0: 3435 : 4	New background pixel contrast	0
0: 3436 : 0	termination_code	0 x 0 ffffff
0: 3440 : 0	SP_DCCMD Code \$ ff (CMD_END)	

FIG. 12

INTERNATIONAL SEARCH REPORT

International Application No

PCT/EP 00/09951

A. CLASSIFICATION OF SUBJECT MATTER

IPC 7 H04N9/82

According to International Patent Classification (IPC) or to both national classification and IPC

B. FIELDS SEARCHED

Minimum documentation searched (classification system followed by classification symbols)

IPC 7 H04N

Documentation searched other than minimum documentation to the extent that such documents are included in the fields searched

Electronic data base consulted during the international search (name of data base and, where practical, search terms used)

EPO-Internal

C. DOCUMENTS CONSIDERED TO BE RELEVANT

Category °	Citation of document, with indication, where appropriate, of the relevant passages	Relevant to claim No.
A	EP 0 875 893 A (DEUTSCHE THOMSON-BRANDT GMBH) 4 November 1998 (1998-11-04) the whole document ---	1,4
A	EP 0 797 201 A (PIONEER ELECTRONIC CORPORATION) 24 September 1997 (1997-09-24) page 13, line 10 -page 14, line 31; figure 8 -----	1,4

Further documents are listed in the continuation of box C.

Patent family members are listed in annex.

° Special categories of cited documents :

- *A* document defining the general state of the art which is not considered to be of particular relevance
- *E* earlier document but published on or after the international filing date
- *L* document which may throw doubts on priority claim(s) or which is cited to establish the publication date of another citation or other special reason (as specified)
- *O* document referring to an oral disclosure, use, exhibition or other means
- *P* document published prior to the international filing date but later than the priority date claimed

- *T* later document published after the international filing date or priority date and not in conflict with the application but cited to understand the principle or theory underlying the invention
- *X* document of particular relevance; the claimed invention cannot be considered novel or cannot be considered to involve an inventive step when the document is taken alone
- *Y* document of particular relevance; the claimed invention cannot be considered to involve an inventive step when the document is combined with one or more other such documents, such combination being obvious to a person skilled in the art.
- *&* document member of the same patent family

Date of the actual completion of the international search

8 February 2001

Date of mailing of the international search report

14/02/2001

Name and mailing address of the ISA

European Patent Office, P.B. 5818 Patentlaan 2
NL - 2280 HV Rijswijk
Tel. (+31-70) 340-2040, Tx. 31 651 epo nl,
Fax: (+31-70) 340-3016

Authorized officer

Verleye, J

INTERNATIONAL SEARCH REPORT

Information on patent family members

International Application No

PCT/EP 00/09951

Patent document cited in search report		Publication date	Patent family member(s)	Publication date
EP 875893	A	04-11-1998	DE 19713069 A	01-10-1998
			CN 1197271 A	28-10-1998
			JP 11007716 A	12-01-1999

EP 797201	A	24-09-1997	JP 9261584 A	03-10-1997
			US 6157769 A	05-12-2000
