



US00D342045S

United States Patent [19]

[11] Patent Number: **Des. 342,045**

Kivett

[45] Date of Patent: **** Dec. 7, 1993**

[54] **BOAT TRAILER WITH ROLLER GUIDES**

4,997,332	3/1991	Johnson	280/414.1
5,002,299	3/1991	Firehammer	280/414.1
5,024,312	6/1991	Godbersen	193/37

[76] Inventor: **Robert L. Kivett**, P.O. Drawer 590,
Clinton, N.C. 28328

Primary Examiner—Wallace R. Burke
Assistant Examiner—Melody Brown
Attorney, Agent, or Firm—Terry M. Gernstein

[**] Term: **14 Years**

[21] Appl. No.: **914,702**

[57] **CLAIM**

[22] Filed: **Jul. 20, 1992**

The ornamental design for a boat trailer with roller guides, as shown and described.

[52] U.S. Cl. **D12/101**

[58] Field of Search D12/101; 280/414.1;
414/534

DESCRIPTION

[56] **References Cited**

U.S. PATENT DOCUMENTS

D. 267,559	1/1983	Wormser	D12/101
4,620,716	11/1986	Carbone	280/414.1
4,717,165	1/1988	Johnson	280/414.1
4,875,700	10/1989	Monroe	280/414.1
4,893,828	9/1990	Godbersen	280/414.1
4,900,216	2/1990	Godbersen	414/534

FIG. 1 is a top, front and side perspective view of the boat trailer with roller guides embodying the design of the present invention;

FIG. 2 is a front end elevational view thereof;

FIG. 3 is a rear end elevational view thereof;

FIG. 4 is a side elevational view thereof, the side opposite being a mirror image of the side shown in FIG. 4;

FIG. 5 is a top plan view thereof; and,

FIG. 6 is a bottom view thereof.

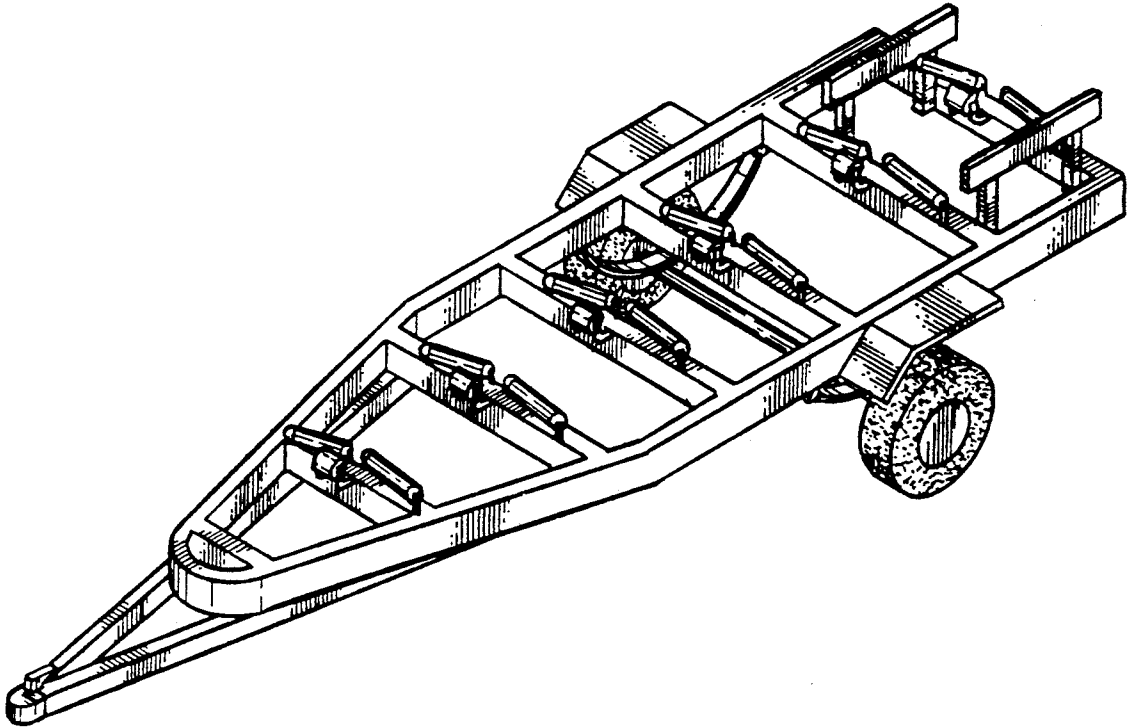

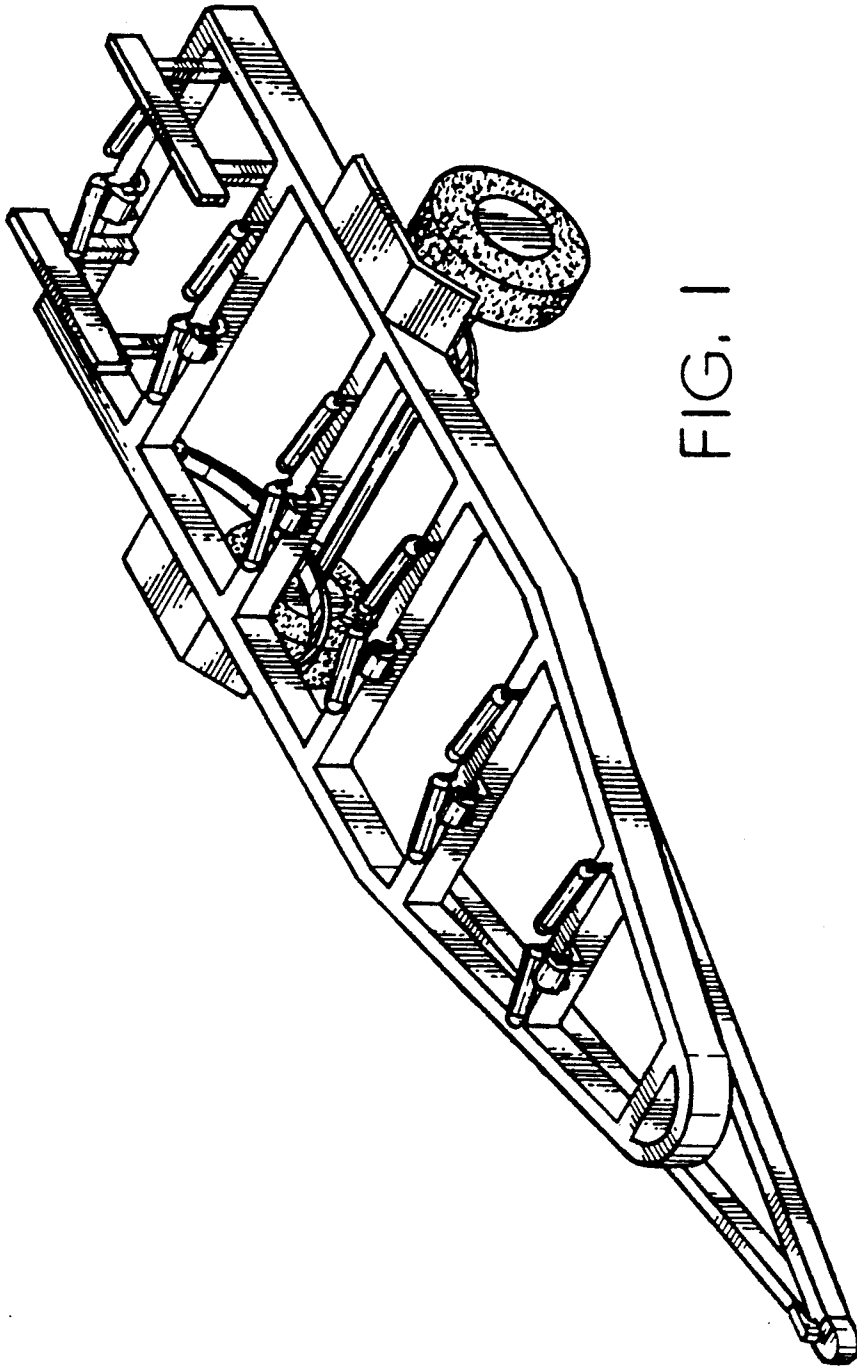

FIG. 1

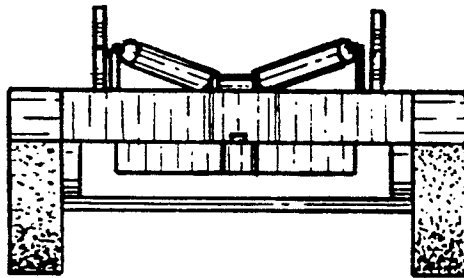

FIG. 2

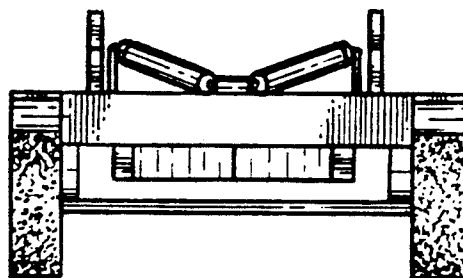

FIG. 3

FIG. 4

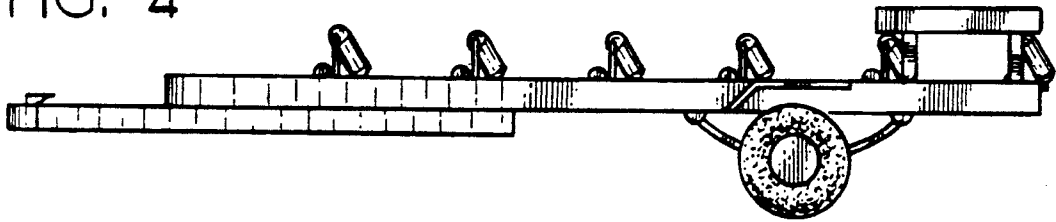

FIG. 5

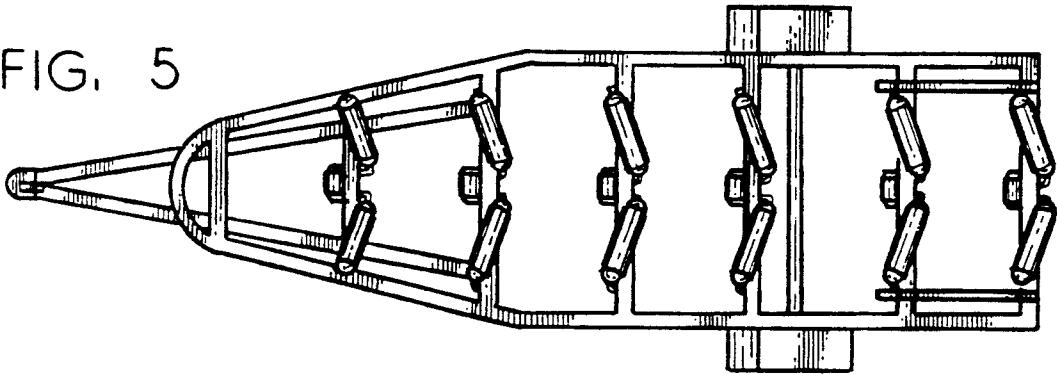

FIG. 6

