

(19)



(11)

EP 2 079 110 A1

(12)

EUROPEAN PATENT APPLICATION

(43) Date of publication:

15.07.2009 Bulletin 2009/29

(51) Int Cl.:

H01L 27/15^(2006.01)

G09F 13/02^(2006.01)

(21) Application number: **08000254.6**

(22) Date of filing: **09.01.2008**

(84) Designated Contracting States:

**AT BE BG CH CY CZ DE DK EE ES FI FR GB GR
HR HU IE IS IT LI LT LU LV MC MT NL NO PL PT
RO SE SI SK TR**

Designated Extension States:

AL BA MK RS

(72) Inventor: **Chen, Yi-Chun
Taichung City (TW)**

(74) Representative: **Reichel, Wolfgang
Reichel und Reichel Patentanwälte
Parkstrasse 13
60322 Frankfurt am Main (DE)**

(71) Applicant: **Safety Traffic Equipment Co., Ltd.
West District
Taichung City (TW)**

(54) **LED projecting lamp structure**

(57) A projecting lamp structure, depending on an area of a panel to be projected, is provided with a flank fixing rack (21), a top-and-bottom fixing rack (22), a revolving padlock (23), a three-way padlock (24), a three-way rack (26), a T rack (27), a four-way rack (28), an upright rack (29), a joint rack and the like required for assembly. Several lamp rack units (1) are fixed to and located in said structure. The lamp rack unit (1) is a long

thin steel rack and distributed in parallel for several LED sources (11). The LED sources (11) are connected in parallel to each other. The steel rack may be provided with a joint connected between a securing seat (2) and a connection seat (3), making the LED projecting lamp unit to be flexibly arranged in an area to be projected for more power saving, more even light, longer service life, and higher degree of recognition.

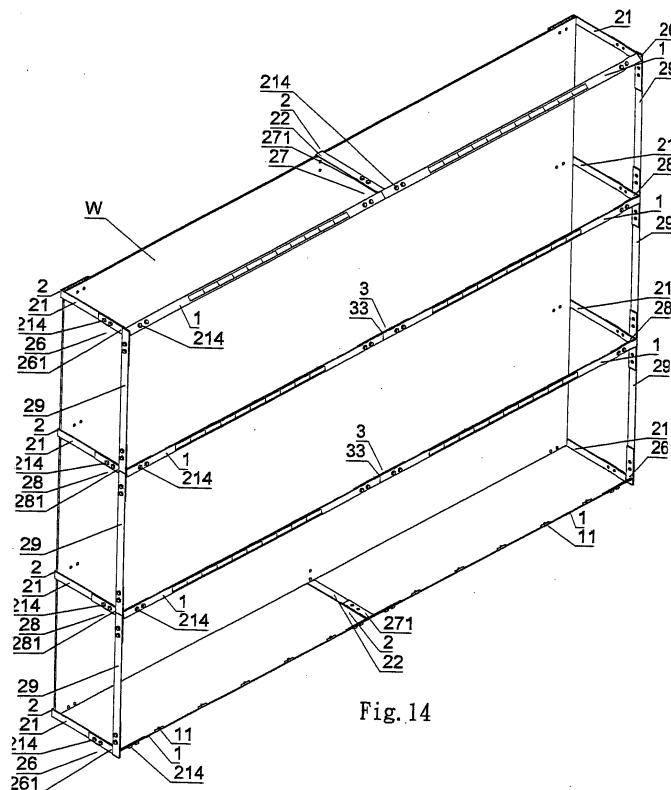

Fig. 14

EP 2 079 110 A1

Description

BACKGROUND OF THE INVENTION

1. Field of the Invention

[0001] This invention relates to a LED projecting lamp structure provided with a white light LED featured with a low weight, a small volume, a wide-angle irradiation, a low attenuation, being assembled with several fixing mount comprising a flank fixing rack, a top-and-bottom fixing rack, a revolving padlock, a three-way padlock, a three-way rack, a T rack, a four-way rack, a lengthwise rack, and several link mounts comprising a middle-piece fixing rack, a two-way padlock, and a joint rack designed for an assembly match, being used for various traffic signs, advertisement boards, notice boards and the like as externally projected light sources.

2. Description of Related Art

[0002] A conventional projecting lamp unit is generally provided for a traffic sign and an advertisement board that projects upwards or downwards, frequently being used with a halogen cup lamp or a halogen strip lamp or a halogen bulb. The halogen lamp is lower in price, longer in service life, and higher in brightness and efficiency than a tungsten lamp, may prevent filamentary cathode from splitting early, and may be electrified in a higher temperature to illuminate, thereby the brightness and efficiency being higher. The halogen lamp is covered with a silica glass of which a melting point is higher; a normal glass is not adapt for a higher temperature condition, so it is inferior in the capability of UV blockage.

[0003] Consequently, because of the technical defects described above, the applicant keeps on carving unflaggingly through wholehearted experience and research to develop the present invention, which can effectively improve the defects described above.

[0004] It is a drawback in a bulb of a conventional projecting lamp unit that it generates an optical energy converted from an electric energy, in which around 5% of the optical energy is occupied from the optical energy, and 95% of the optical energy is converted into a heat energy that is not needed; thus, the power is consumed very much, and the power must be supplied remotely for generation of the light source in great quantity.

[0005] A further drawback in the state of the art is that a predetermined supporting capability must be applied to the conventional projecting lamp unit to bear the weight of a bulb seat and a bulb, so a structure of a certain volume must be provided to bear the weight of a pressure applied by the bulb seat and bulb; an issue of affecting a line of sight also occurs.

[0006] The bulb light is emitted from an interior to an exterior in a form of sphere. Hence, it is a further drawback in the state of the art that, when a ray of light reaches a plane, the intensity of illumination is certainly uneven.

In order to repair the defect, the bulb that is located must be added in amount, wherein the cost of bulb increases.

SUMMARY OF THE INVENTION

5

[0007] It would be desirable, therefore, to use an LED lamp featured with a low voltage, a low current, and a low conversion loss and match them with a solar power panel or a small windmill as a power accumulator for achievement of self-power-saving, wherein no extra power supply being required.

10

[0008] It would be further desirable to distribute the LED light on a long thin lamp rack unit. The volume of said lamp rack unit occupies a small area, so the board surface is easily recognized from a distance, thereby a degree of recognition of the board surface being not affected and the ray of light given by the projecting lamp being even.

15

[0009] It would be further desirable if several fixing racks are spirally locked and fixed at a rear of a large billboard, and thus the structure is formed with several flank fixing racks, a top-and-bottom fixing rack, a middle piece rack, several revolving padlocks, a two-way padlock, a three-way padlock, several three-way racks, a T

20

25

[0010] It would be further desirable if several lamp rack units are locked to and provided in the structure for the white-light LED projecting lamp unit to be arranged in an area of projection. Compared with the conventional projecting lamp unit, this may save more power, make the illumination even, and serve longer in a condition of equal area and illumination for achievement of wide illumination.

30

[0011] These objects being solved in accordance with the present invention as defined in claim 1. Advantageous embodiments are given in the dependent claims.

35

BRIEF DESCRIPTION OF THE DRAWINGS

40

[0012] The objects and advantages of the present invention will be understood by reading the following detailed description in conjunction with the drawings, in which:

45

Fig. 1 is a 3D view of a lamp rack unit according to this invention;

Fig. 2 is a side view of the lamp rack unit according to this invention that illuminates;

50

Fig. 3 is a 3D exploded view of a first embodiment of this invention.

Fig. 4 is a 3D assembly view of the first embodiment of this invention;

55

Fig. 5 is a 3D exploded view of a second embodiment of this invention;

Fig. 6 is a 3D assembly view of the second embodiment of this invention;

Fig. 7 is a 3D exploded view of a third embodiment of this invention;

Fig. 8 is a 3D assembly view of the third embodiment of this invention;

Fig. 9 is a 3D exploded view of a fourth embodiment of this invention;

Fig. 10 is a 3D assembly view of the fourth embodiment of this invention;

Fig. 11 is a 3D assembly view of a fifth embodiment of this invention;

Fig. 12 is a 3D exploded view of a sixth embodiment of this invention;

Fig. 13 is a 3D assembly view of the sixth embodiment of this invention; and

Fig. 14 is a 3D assembly view of a seventh embodiment of this invention.

DETAILED DESCRIPTION OF THE PREFERRED EMBODIMENTS

[0013] Now, the present invention will be described more specifically with reference to the following embodiments. It is to be noted that the following descriptions of preferred embodiments of this invention are presented herein for purpose of illustration and description only; it is not intended to be exhaustive or to be limited to the precise form disclosed.

[0014] With reference to Fig. 1 and Fig. 2, a LED is used, being featured inclusively with a small volume, a low weight, a fast reaction, a long service life, a low attenuation, a strong exterior, an anti-vibration, an easy direction design, a low voltage, a low current, a low conversion loss, a low heat radiation, an easy yield, and an environmental protection on a long thin lamp rack unit 1. Several white-light LEDs 11 are arranged on a circuit and distributed side by side. Said LEDs 11 are arranged in parallel and independent, and their pedestal are adhered with glue or fixed with a plug dowel. Two terminals of the lamp rack unit 1 are changed in different manners of fixing and located by using several securing seats 2 and connection seats 3.

[0015] With reference to Fig. 3 and Fig. 4 and Figs. 7 through 8, a small billboard W or a notice board being projected for illumination. Several locating holes 12 may be provided at one end of the lamp rack unit 1 and several latches 13 for the holes are provided at the other terminal. The securing seat 2 may be a flank fixing rack 21 of which one terminal is fixed with screws to two flanks at a rear

of the small billboard W and the other terminal is formed with an annular hole 211 corresponding to the hole of said latch 13 for clamping at an angle required. The white-light LEDs 11 are separately distributed in parallel, so that the light source given from the projecting lamp being evenly scattered on the billboard W for evenly distributed rays of light. The white-light LEDs 11 are connected in parallel, and in case that a single lamp is damaged, the rests of lamps are not affected and keep working; thus, only the damaged white-light LED 11 could be replaced, thereby the performance of said projecting lamp unit being increased and low cost of repair being achieved. Several locating holes 12 may be formed at two terminals of the lamp rack unit 1, and several wedge holes 212 are alternatively formed at the other terminal of the flank fixing rack 21 and wedged in a revolving mount 231 of the revolving padlock 23. The revolving padlock 23 is formed in the structure of said securing seat 2 to adjust a revolving plate 232 of the revolving padlock 23 for a required angle of illumination, and thus the locating holes 12 at the two terminals of the lamp rack unit 1 are respectively wedged into the revolving plate 232 with the revolving padlock 23 for location in another manner. Said several locating holes 12 may be formed at the two terminals of the lamp rack unit 1, and several locating holes 213 are alternatively formed at the other terminal of the flank fixing rack 21 and locked with a screw 214 to a terminal of a two-way rack 25. Said two-way rack 25 is formed in the structure of said securing seat 2 at the required angle of illumination, and thus the locating holes 12 at the two terminals of said lamp rack unit 1 are spirally locked to the other terminal of each of the 2 two-way racks 25 respectively, which is another manner for assembly.

[0016] With reference to Figs. 5, 6, 9, and 10, when a large billboard W or an advertisement board is projected for illumination, the securing seat 2 may be in the form of several flank fixing racks 21. A top-and-bottom fixing rack 22 is spirally locked to a rear side of the large billboard W and the other terminal is formed with the annular hole 211 corresponding to the hole of said latch 13. Further, several fixing holes 221 and several lamp rack units 1 are provided and locked at the angle of illumination onto the flank fixing rack 21 and the top-and-bottom fixing rack 22. A middle connection seat 3 may be a middle piece rack 31 provided with several connection holes 311 locked to the opposite terminals of said two lamp rack units 1. Several wedge holes 212 are alternatively formed at the other terminal of the flank fixing rack 21, and the flank fixing rack 21 and the top-and-bottom fixing rack 22 are respectively wedged into the revolving mount 231 of said revolving padlock 23 and a buckle mount 241 of the three-way padlock 24. The revolving padlock 23 and the three-way padlock 24 are formed in the structure of said securing seat 2 to adjust a revolving plate 232 and a buckle plate 242 for the required angle of illumination. During installing, the lamp rack unit 1 wedges the locating holes 12 at the two terminals into said revolving plate 232 and the buckle plate 242. The middle connection seats

3 may be the two-way padlocks 32 that may be wedged to the opposite terminals of the two lamp rack unit 1. Several locating holes 213 are alternatively formed at the other terminal of the flank fixing rack 21, and the flank fixing rack 21 and the top-and-bottom fixing rack 22 are respectively locked with screws 214 to lock holes 262 in a rack 261 of a three-way rack 26, lock holes on a base 271 of a T rack 27, lock holes 282 on a base 281 of a four-way rack 28, and lock holes 291 in an upright rack 29. The three-way rack 26, the T rack 27, the four-way rack 28, and the upright rack 29 are formed in the structure of securing seat 2, and the three-way rack 26, the T rack 27, and the four-way rack 28 are formed at the required angle of illumination. So the locating holes 12 at the two terminals of the lamp rack unit 1 are respectively spirally locked onto the lock holes 262 at one terminal of each three-way rack 26, the lock holes 272 at the two opposite terminals of the T rack 27, and the lock holes 282 at an inner terminal of the four-way rack 28. The upright rack 29 is spirally fixed between the three-way rack 26 and the four-way rack 28 to enhance the strength and durability of the structure, and the middle connection seat 3 may be a link mount 33 provided with several fixing holes that may be spirally fixed to the opposite terminals of said two lamp rack units 1 so that the white-light LED projecting lamp unit may be flexibly arranged in an area to be projected in the requirements of equal area and equal illumination for more power saving, more even light, and longer service life, thereby a wide illumination being achieved.

[0017] With reference to Fig. 5 and FIG. 9, from the description mentioned on the structure, a plurality of layers of illumination racks may be assembled with the securing seat 2 and the connection seat 3. The white-light LED lamps 11 are distributed in parallel on several long thin lamp rack units 1; the lamp rack unit 1 of which having a volume that occupies a small area, so that the surface of said billboard W is easily recognized from a distance, thereby a degree of recognition of the board surface being not affected and the ray of light given by the projecting lamp being even. The white-light LED lamp 11 featured with a low voltage, a low current, and a low conversion loss may be matched with a solar power panel or a small windmill as a power accumulator for achievement of self-power-saving, thereby no extra power supply being required.

[0018] In this invention, the white-light LED lamps 11 are distributed in parallel on the lamp rack unit 1, because of the fact that they are featured with the low weight, small volume, and even light scattering. Further, they are assembled with different securing seats 2 and connection seats 3 for a practical benefit of external light source projecting.

[0019] While the invention has been described in terms of what is presently considered to be the most practical and preferred embodiments, it is to be understood that the invention needs not be limited to the disclosed embodiment. On the contrary, it is intended to cover various

modifications and similar arrangements included within the scope of the appended claims which are to be accorded with the broadest interpretation so as to encompass all such modifications and similar structures.

Claims

1. A projecting lamp structure, being used for a traffic sign, an advertisement board, a notice board and the like as an externally projecting light source, **characterized in that** a long thin lamp rack unit (1) is provided with several LED sources (11) on a circuit and distributed in parallel, the LED sources (11) are arranged in parallel and independent of each other, wherein two terminals of the lamp rack unit (1) are changed in different manners of fixing and being located by using several securing seats (2) and connection seats (3) so that the LED sources (11) may be arranged in an area to be projected for more power saving, more even light, longer service life, and higher degree of recognition as sound effects of illumination.
2. The projecting lamp structure according to claim 1, wherein the LED source (11) may be a white LED or a yellow LED.
3. The projecting lamp structure according to claim 1 or 2, wherein a pedestal of said LED source (11) is adhered with glue or fixed with a plug dowel.
4. The projecting lamp structure according to one of claims 1 to 3, wherein a power supply to the LED source (11) may be a solar cell or a fan driven generator for achievement of self-power supply, or may be given externally.
5. The projecting lamp structure according to one of claims 1 to 4, wherein the long thin lamp rack unit (1), the securing seat (2), and the connection seat (3) may be of a material comprising steel, aluminum, or aluminum alloy.
6. The projecting lamp structure according to one of claims 1 to 5, wherein the securing seat (2) may be a flank fixing rack (21), a top-and-bottom fixing rack (22), a revolving padlock (23), a three-way padlock (24), a three-way rack (26), a T rack (27), a four-way rack (28), an upright rack (29) and the like.
7. The projecting lamp structure according to one of claims 1 to 6, wherein the connection seat (3) may be a middle-piece fixing rack (31), a two-way padlock (32), and a joint rack.

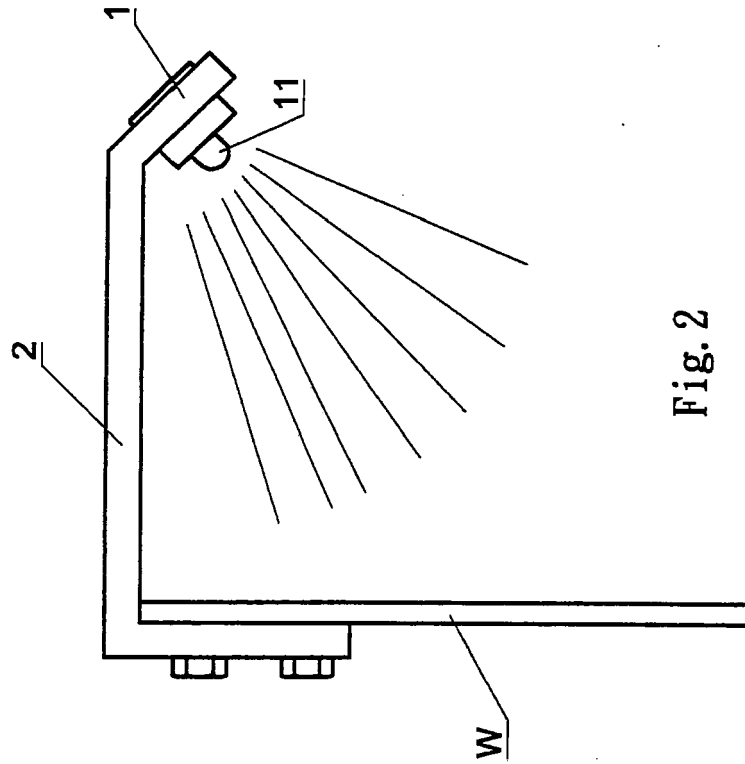

Fig. 2

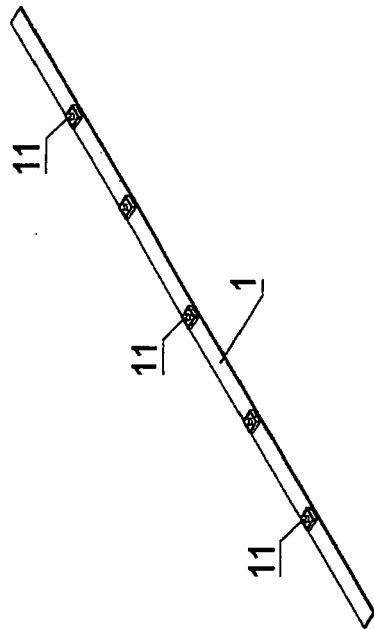

Fig. 1

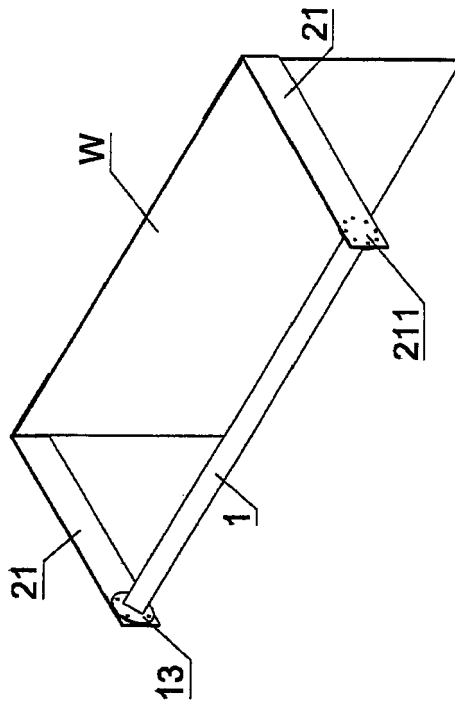

Fig. 4

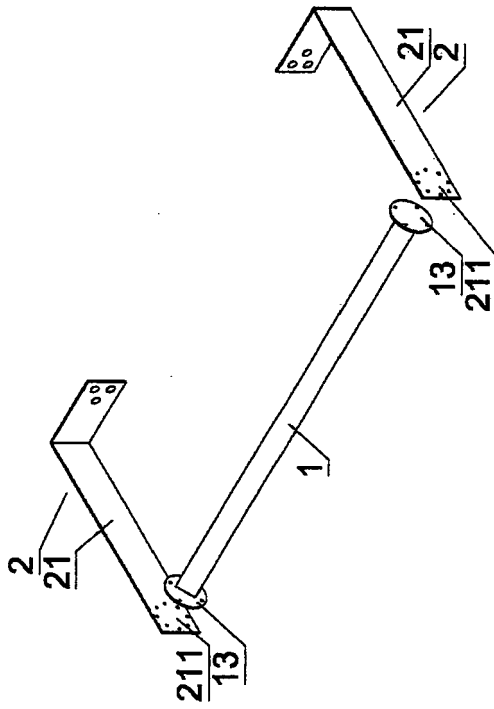

Fig. 3

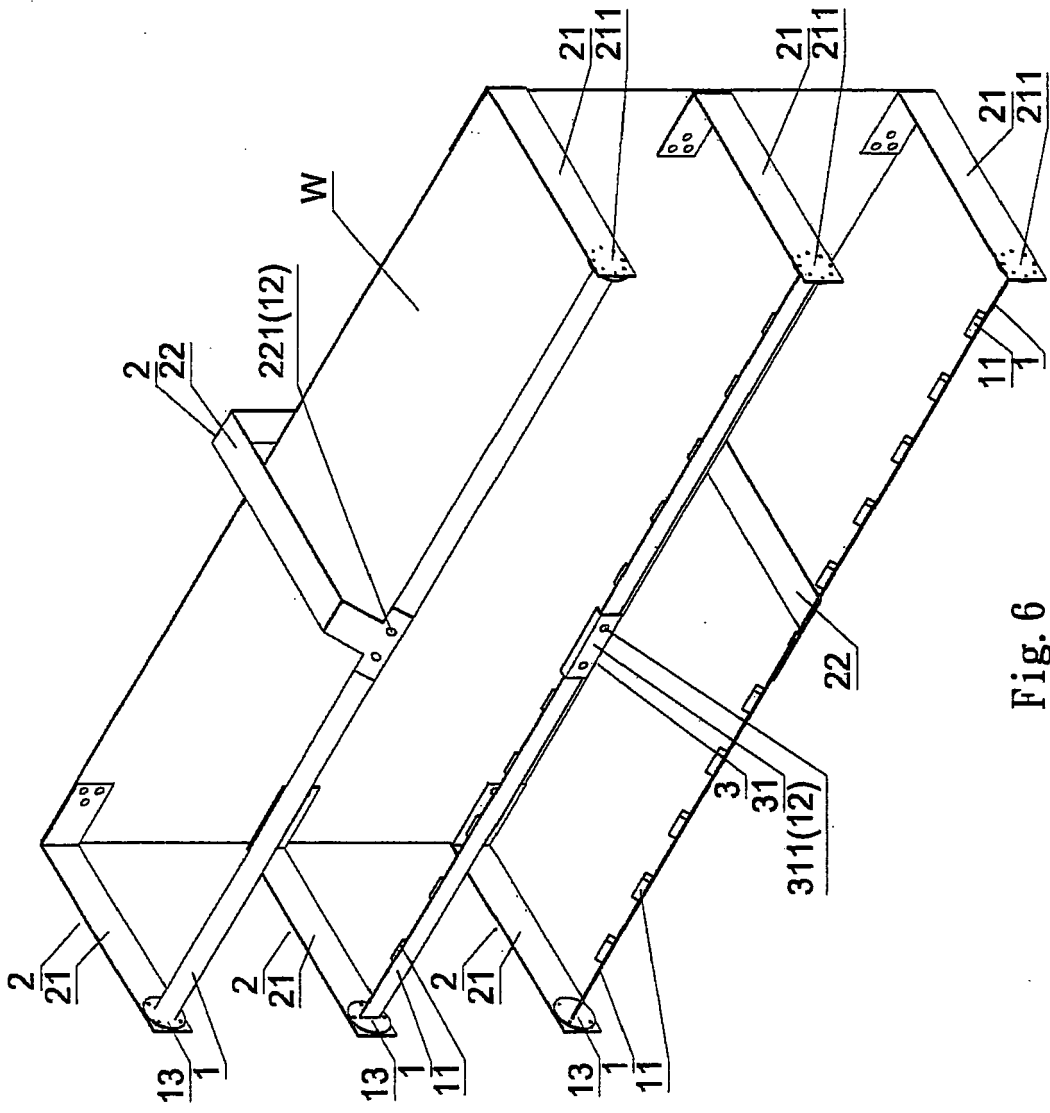

Fig. 6

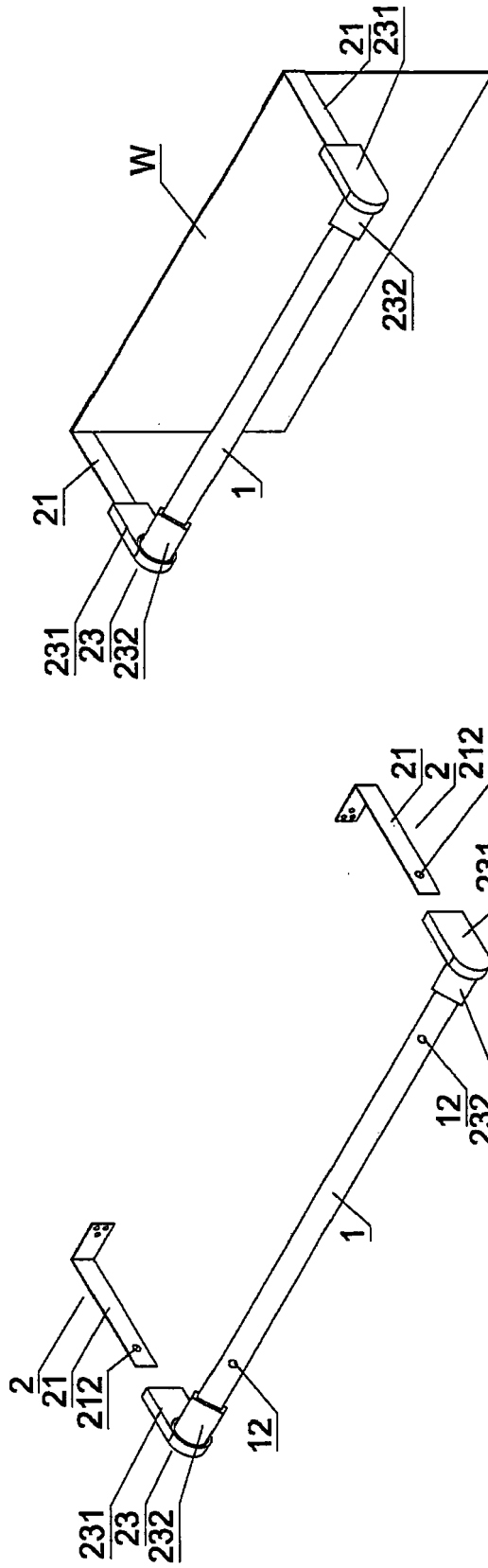

Fig. 8

Fig. 7

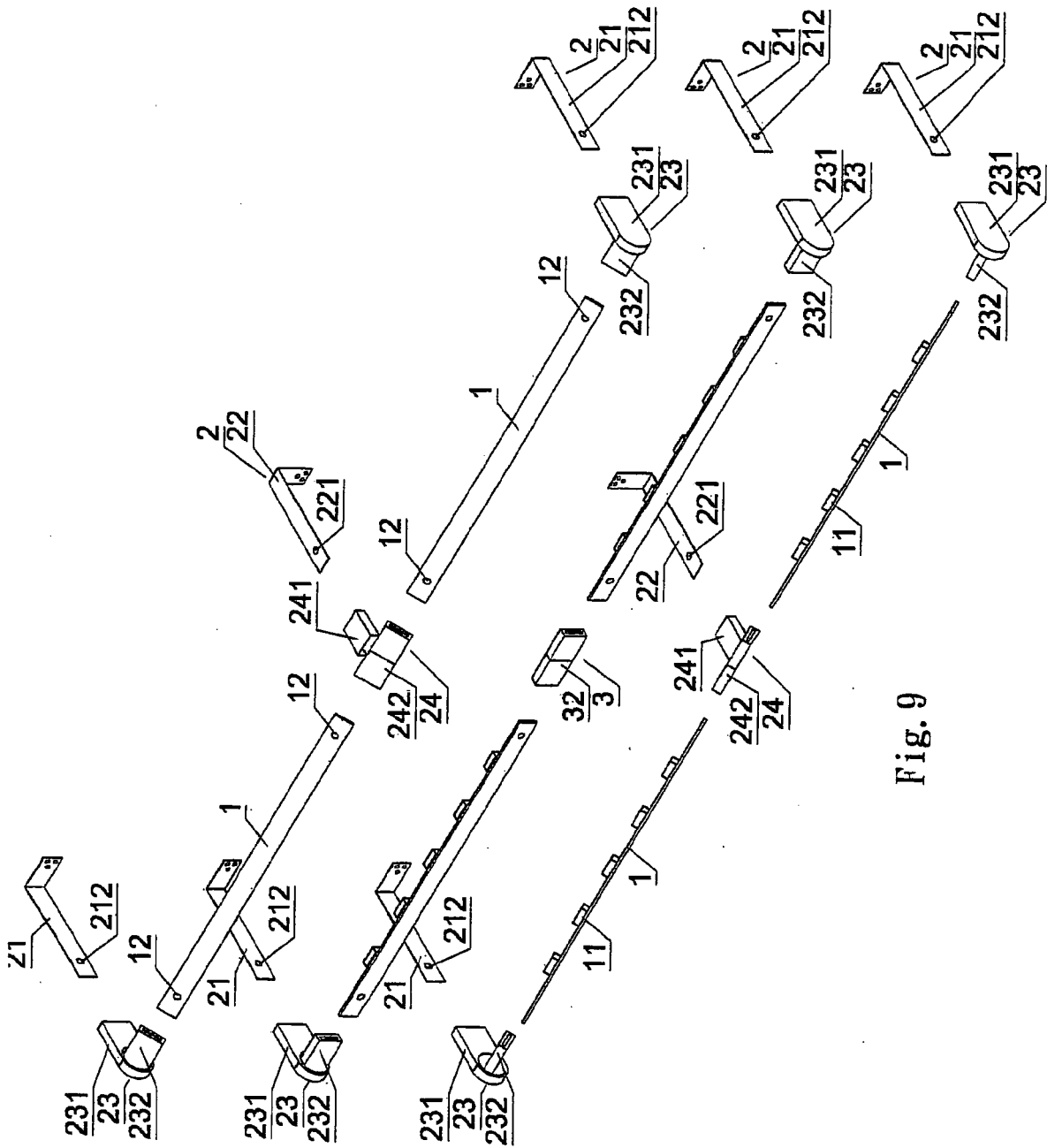

Fig. 9

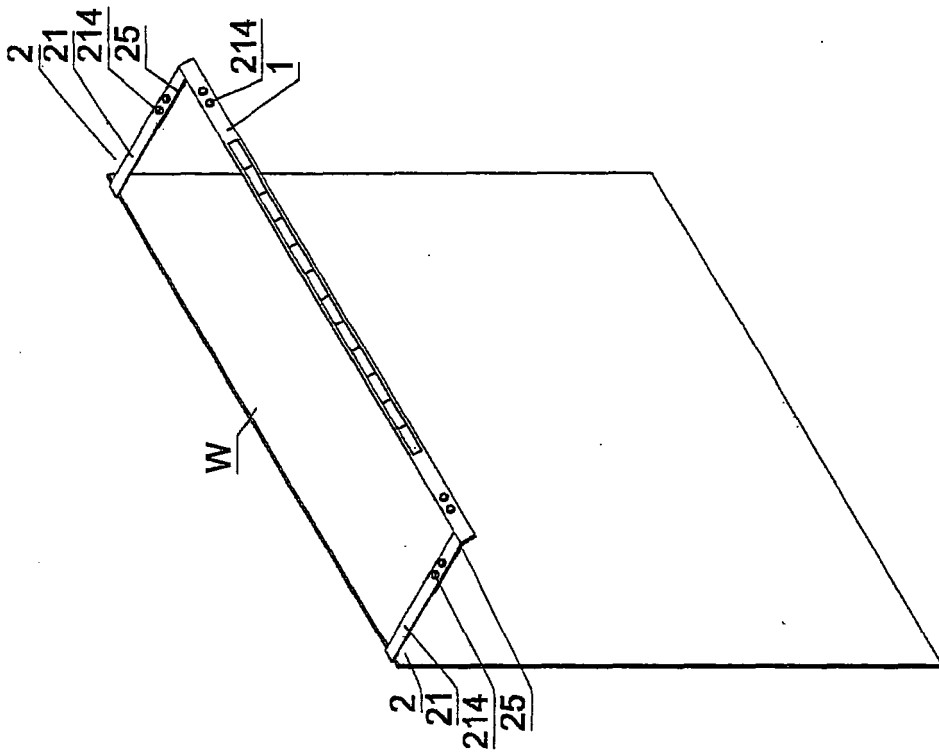

Fig. 11

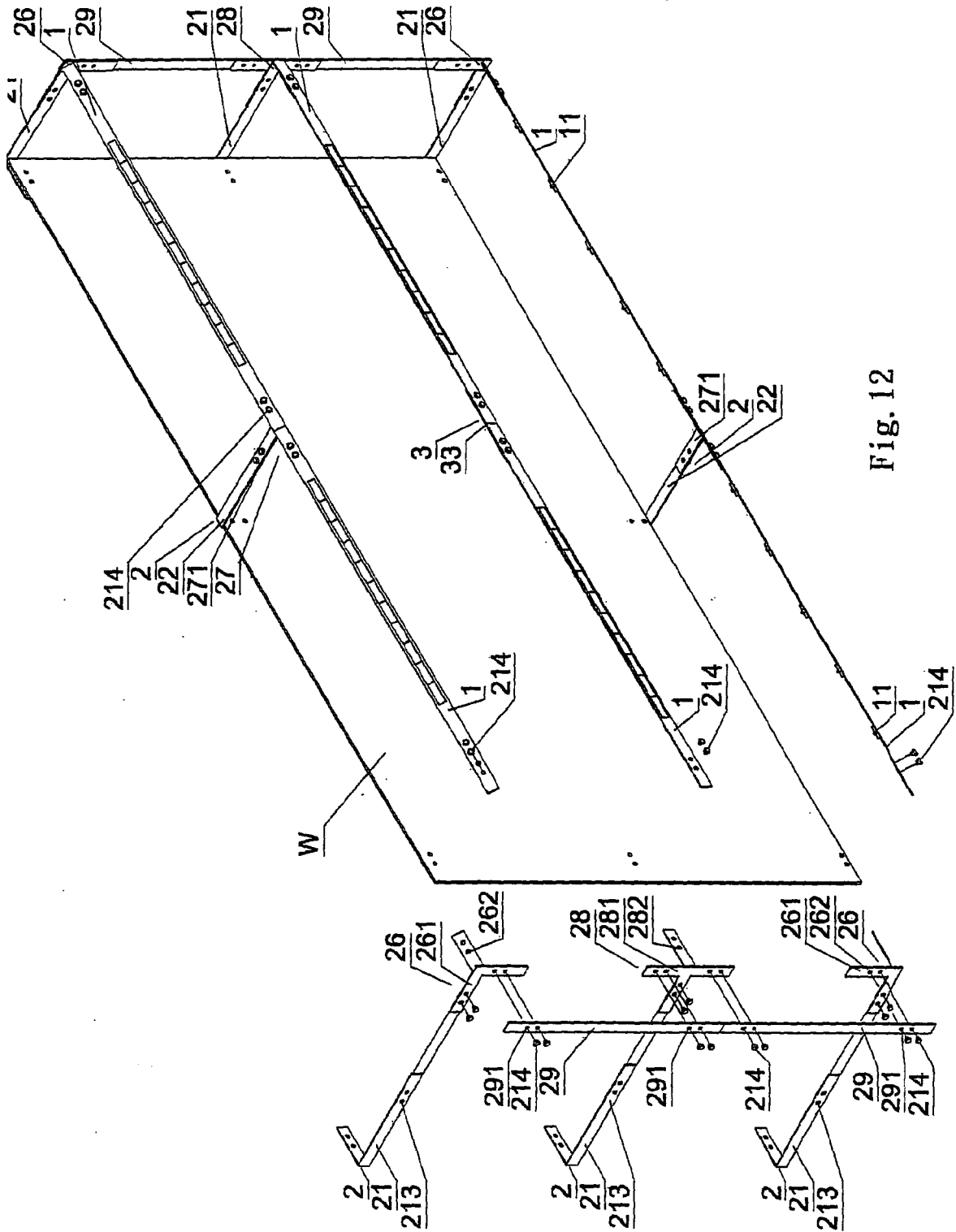

Fig. 12

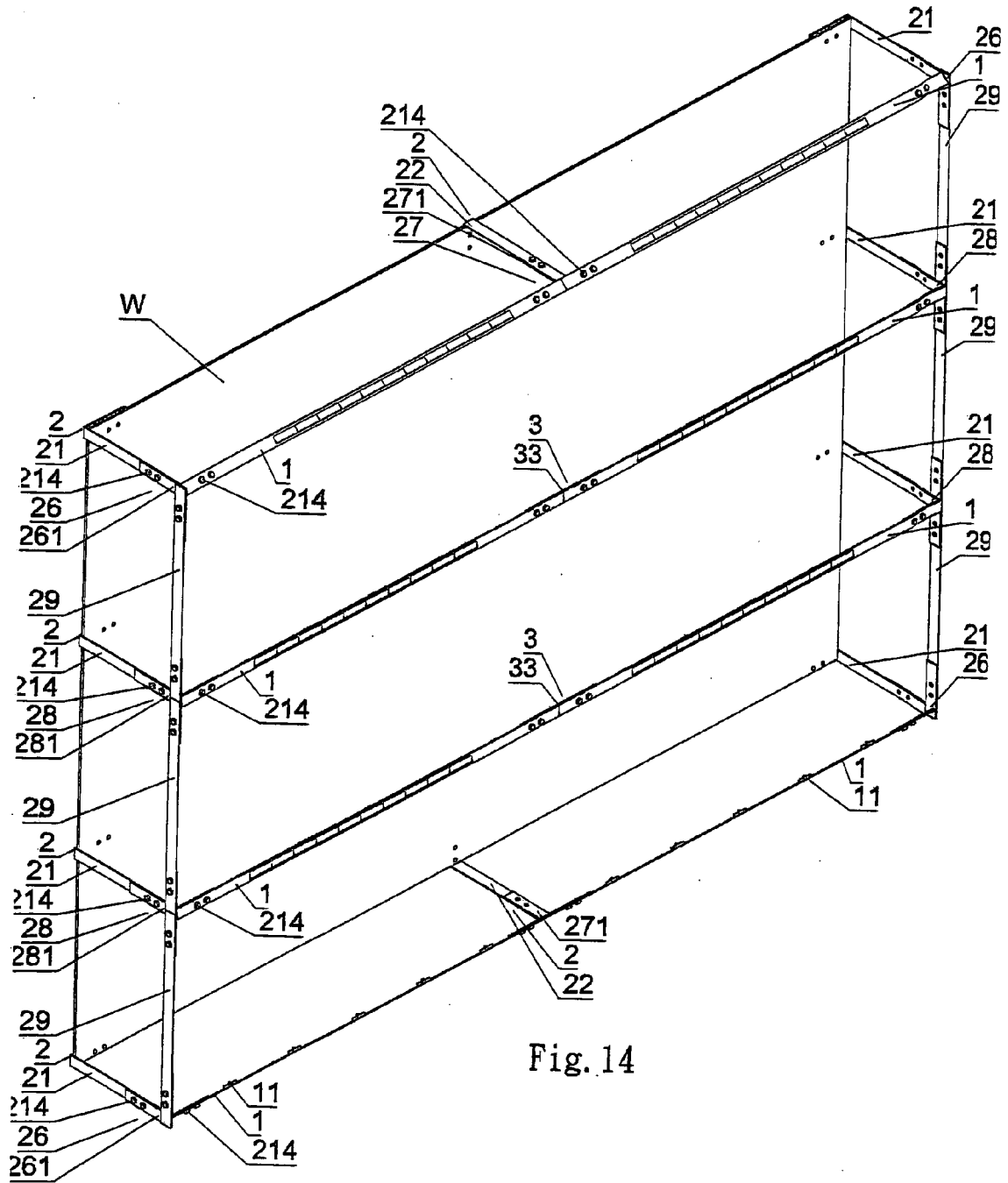

Fig. 14



DOCUMENTS CONSIDERED TO BE RELEVANT			
Category	Citation of document with indication, where appropriate, of relevant passages	Relevant to claim	CLASSIFICATION OF THE APPLICATION (IPC)
X	US 6 510 633 B1 (BLEDSOE WILLIAM C [US]) 28 January 2003 (2003-01-28) * column 2, line 26 - column 4, line 25; figures 2,5,6 *	1-6	INV. H01L27/15 G09F13/02
X	----- US 7 181 876 B1 (AHMADI WILLIAM Y [US]) 27 February 2007 (2007-02-27) * column 2, line 30 - line 43; figure 1 *	1-6	
X	----- FR 2 899 008 A (JCDECAUX SA SA [FR]) 28 September 2007 (2007-09-28) * page 4, line 4 - page 6, line 13; figures 1,3 *	1-6	
X	----- US 2003/099105 A1 (WATSON MARION H [US]) 29 May 2003 (2003-05-29) * page 1, paragraph 22 - page 2, paragraph 30; figures 1,4,5 *	1-6	
X	----- US 2006/164833 A1 (PARKYN WILLIAM A [US] ET AL) 27 July 2006 (2006-07-27) * page 1, paragraph 7 - page 3, paragraph 60; claims 1-6; figures 1A,1B,5A *	1-5	
A	-----	6,7	TECHNICAL FIELDS SEARCHED (IPC)
			H01L G09F
The present search report has been drawn up for all claims			
Place of search Munich		Date of completion of the search 6 June 2008	Examiner Pavlov, Valeri
CATEGORY OF CITED DOCUMENTS X : particularly relevant if taken alone Y : particularly relevant if combined with another document of the same category A : technological background O : non-written disclosure P : intermediate document		T : theory or principle underlying the invention E : earlier patent document, but published on, or after the filing date D : document cited in the application L : document cited for other reasons & : member of the same patent family, corresponding document	

2

EPO FORM 1503 03/82 (P04C01)

**ANNEX TO THE EUROPEAN SEARCH REPORT
ON EUROPEAN PATENT APPLICATION NO.**

EP 08 00 0254

This annex lists the patent family members relating to the patent documents cited in the above-mentioned European search report. The members are as contained in the European Patent Office EDP file on
The European Patent Office is in no way liable for these particulars which are merely given for the purpose of information.

06-06-2008

Patent document cited in search report	Publication date	Patent family member(s)	Publication date
US 6510633	B1	28-01-2003	NONE
US 7181876	B1	27-02-2007	NONE
FR 2899008	A	28-09-2007	NONE
US 2003099105	A1	29-05-2003	WO 2005006442 A1 20-01-2005
US 2006164833	A1	27-07-2006	US 2007058369 A1 15-03-2007