

Nov. 24, 1931.

H. C. LEHN

1,833,083

SPARK DISTRIBUTOR

Filed May 25, 1928

3 Sheets-Sheet 1

Fig. 1.

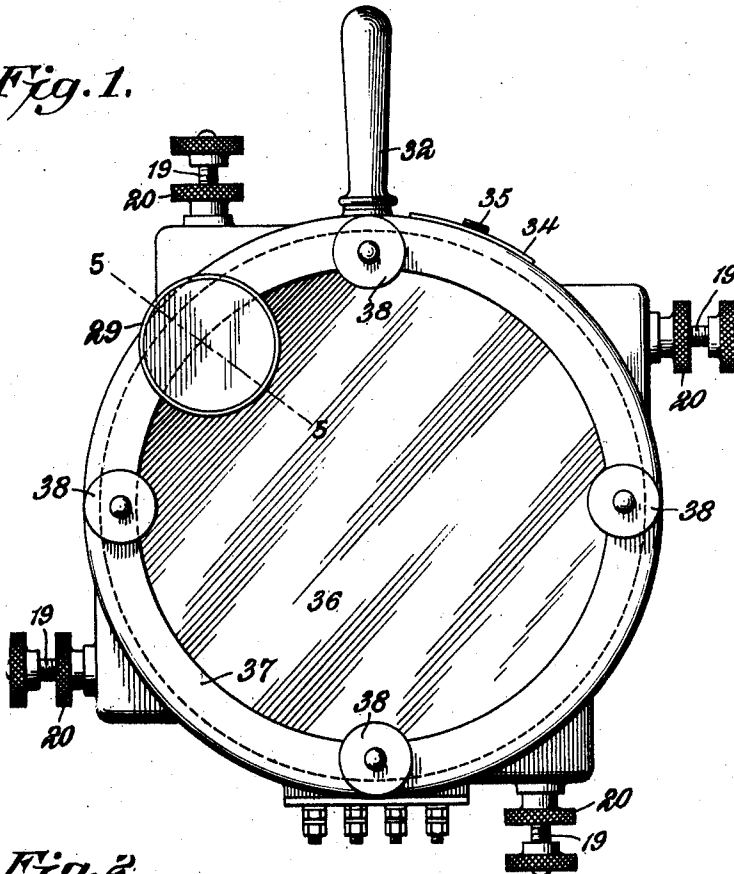
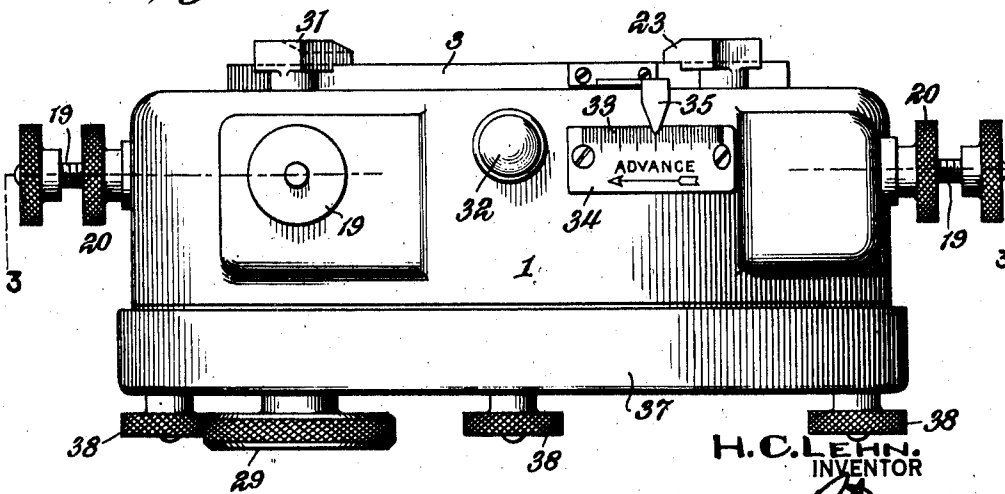

Fig. 2.



H. C. LEHN.
INVENTOR

BY *Robert Meyer*
ATTORNEY

Nov. 24, 1931.

H. C. LEHN

1,833,083

SPARK DISTRIBUTOR

Filed May 25, 1928

3 Sheets-Sheet 2

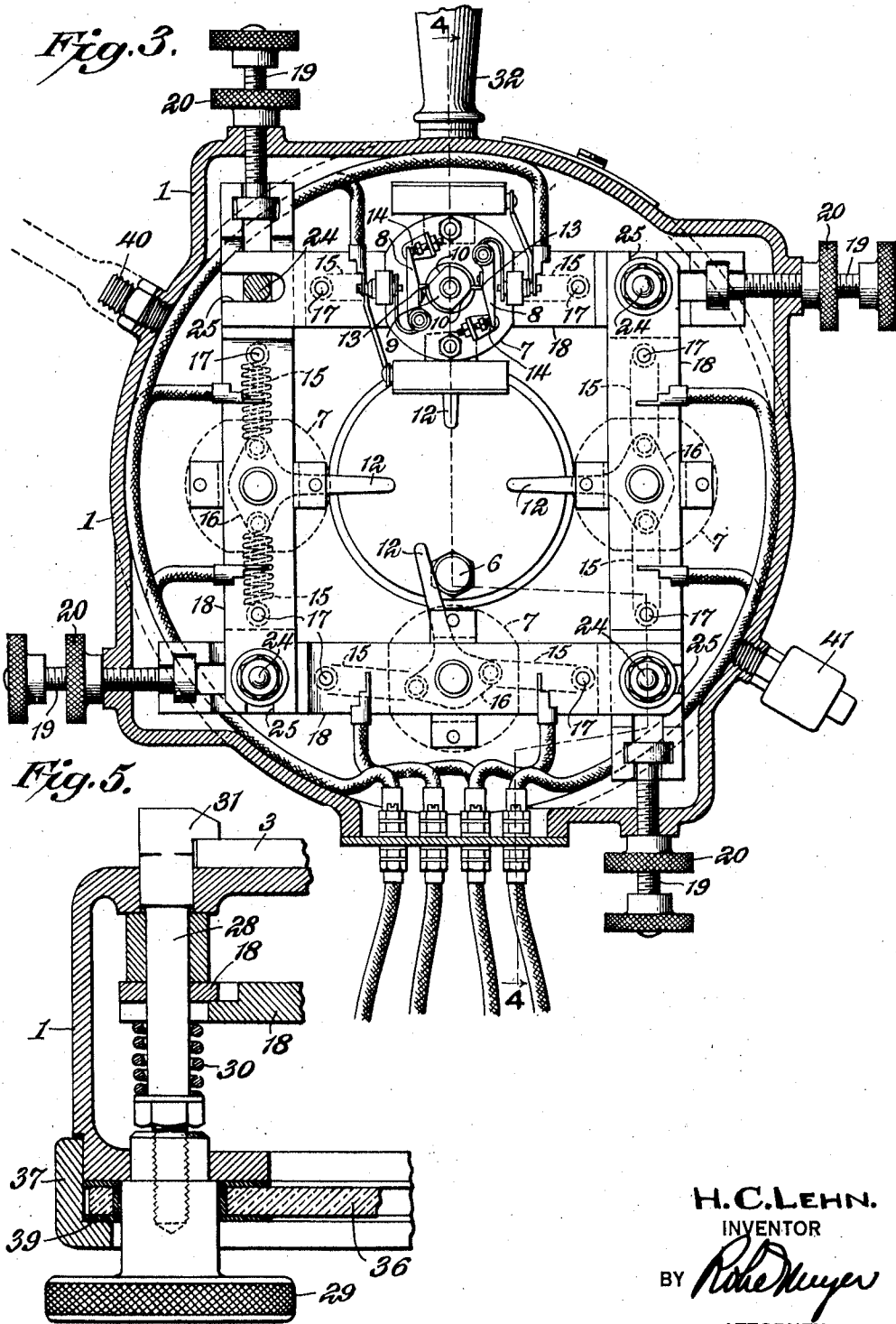

H. C. LEHN.
INVENTOR
BY *Robert Meyer*
ATTORNEY

Nov. 24, 1931.

H. C. LEHN

1,833,083

SPARK DISTRIBUTOR

Filed May 25, 1928

3 Sheets-Sheet 3

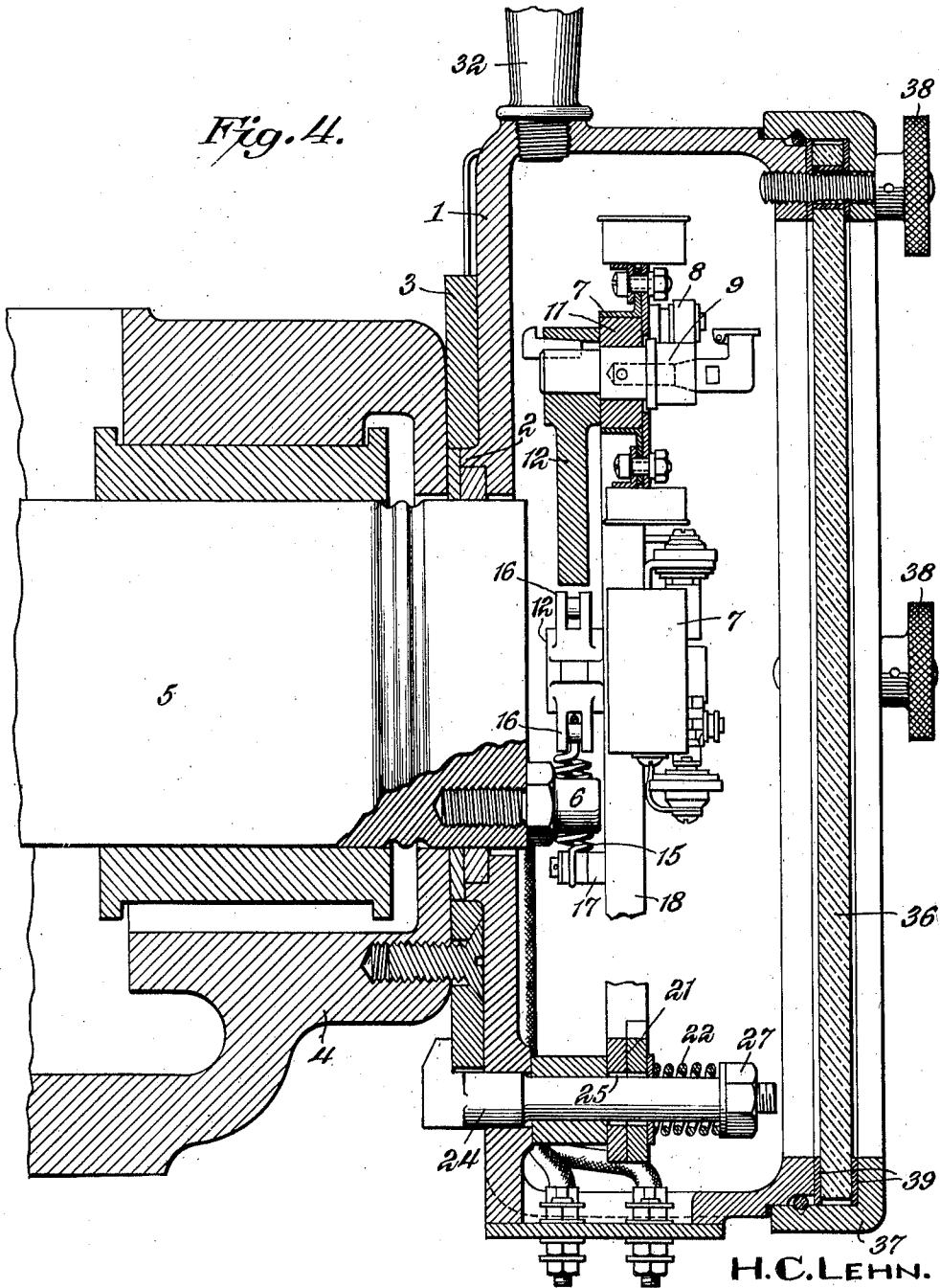

H.C. LEHN.
INVENTOR
BY *Robert Meyer*
ATTORNEY

UNITED STATES PATENT OFFICE

HENRY C. LEHN, OF BUFFALO, NEW YORK, ASSIGNOR TO WORTHINGTON PUMP AND MACHINERY CORPORATION, OF NEW YORK, N. Y., A CORPORATION OF VIRGINIA

SPARK DISTRIBUTOR

Application filed May 25, 1928. Serial No. 280,408.

This invention relates to spark distributors for use in connection with the ignition systems of internal combustion engines.

An object of the invention is to provide in a spark distributor for multiple cylinder engines, novel, relatively simple means to permit accurate independent adjustment of the interrupter assemblies for each cylinder and means to permit simultaneous adjustment of all the interrupter assemblies for advancing or retarding the ignition for all the cylinders of the engine.

Another object of this invention is to provide an interrupter assembly for use in the distributor mechanism of relatively large internal combustion engines, wherein the volume of explosive mixture is such as to require a plurality of spark plugs for each cylinder to ensure the best combustion results, which interrupter structure embodies a plurality of contact makers and breakers corresponding in number to the number of spark plugs required, which contacts are operated in unison to provide simultaneous spark forming energizing of the spark plugs.

In some power stations, particularly those utilizing that type of internal combustion engine known as gas engines, the air is impregnated with the combustible gas and to prevent accumulation of such gas in the distributor and to permit inspection of the interrupter assemblies while in operation, the casing of the distributor is sealed with a transparent cover, and means are provided to permit, at will, the passing of fresh air, under pressure, through the distributor casing.

With these objects in view, the invention consists in various features of construction and combination of parts, which will be first described in connection with the accompanying drawings, showing a spark distributor of the preferred form embodying the invention, and the features forming the invention will be specifically pointed out in the claims.

Fig. 1 is a front elevation of the distributor.

Fig. 2 is a top plan of the distributor.

Fig. 3 is a vertical section through the distributor taken on the line 3—3 of Fig. 2.

Fig. 4 is a section through the distributor taken on the line 4—4 of Fig. 3.

Fig. 5 is a detailed section through the distributor taken on the line 5—5 of Fig. 1.

Referring more particularly to the drawings, the improved spark distributor comprises a casing 1, which has an annular ring 2 on the inner side or back thereof which fits within the adjustment ring 3. The ring 3 is attached in any suitable manner to a part of the engine with which the distributor is used, preferably to the bearing 4 of the cam shaft 5 of the engine, and the end of the cam shaft 5 projects into the casing 1.

An operating pin 6 is carried by the cam shaft and projects beyond its end into the casing 1 for operating the cams of the interrupter assemblies 7. An interrupter assembly 7 is provided for each of the cylinders of the engine as for example, in a 4 cylinder engine there will be 4 interrupter assemblies. All of the interrupter assemblies are the same, or similar in construction and each of them comprises a pair of contact makers and breakers 8 of any approved construction mounted upon opposite sides of the axis of the interrupter assembly. The contact makers and breakers or contacts 8 are operated by a cam 9 which has, in the present instance, two operating surfaces 10 thereon, one for each of the contacts 8 and these surfaces 10 are arranged so that upon oscillation of the cam 9 the contacts 8 will be simultaneously operated to energize two spark plugs simultaneously. The present spark distributor is primarily for use on large internal combustion engines in which the volume of gas or explosive in each cylinder is so great that it is advisable to use two or more spark plugs to ensure the best combustion results in the engine. The two contactors 8 are provided to permit simultaneous sparking of the two spark plugs in each cylinder. The cams 9 are rockably mounted in suitable bearings 11 and they have operating levers 12 connected thereto which project into the path of the operating stud or pin 6, therefore during the rotation of the cam shaft 5 the stud 6 will successively engage the levers

12 of the various interrupter assemblies 7 and operate the cams in sequence for proper firing of the cylinders of the engine with which the spark distributor is used. When the stud 6 engages and moves one of the levers 12, the cam 9 to which the lever 12 is connected, will be oscillated or operated through only a part of a revolution, sufficient to bring the operating surfaces 10 into engagement with the cam engaging members 13 of the contactors 8, permitting contact to be made between the contact points as shown at 14 of the contactors. When the stud 6 has passed the respective lever 12, this lever is returned to its normal position by means of springs 15 which are connected to suitable bosses 16 formed on the lever and to studs 17 mounted upon the interrupter assembly carrying bar 18. The return of the lever 12 to its normal position will move the cam 9 in a reverse direction, returning it to its normal stationary position in which it remains until the lever is again moved by the stud 6. The provision of only two flats or operating surfaces 10 on each of the cams 9 will prevent the occurrence of a spark should the engine, equipped with the improved spark distributor, turn backwards.

Independent adjustment of the interrupter assemblies is permitted, since 4 cycle double acting engines require separate or independent adjustment of the ignition of each cylinder end in order to obtain the best balance of power between the cylinder ends. For this purpose, each of the interrupter assemblies 7 is mounted upon a sliding bar 18 which is adjusted by means of adjusting screw 19 thereon through the casing 1. The sliding bar 18 is held in adjusted position by means of a lock nut 20. The sliding bars supporting alternate interrupter assemblies overlap at the corners as shown at 21 and are held against rotation on their longitudinal axis by means of springs 22, which serve not only this function, but also the function of holding the heads 23 of the clamping T bolts 24 tightly against the ring 3 for attaching the distributor structure to the attaching ring 3. The sliding bars 18 are provided with slots 25 to permit their adjustment over the T bolts 24. By adjustment of the respective adjusting screws 19, the position of any one of the interrupter assemblies 7 may be adjusted relative to the other interrupter assemblies to vary the point of contact of the stud 6 with the respective lever 12.

The nuts 27 and the springs 22 on the T bolts 24 are adjusted to provide sufficient tension to partially hold the casing 1, and a fifth T bolt 28 is provided for rigidly clamping the casing 1 to the attaching plate or ring 3 by means of the hand wheel 29. The T bolt 28 has a tensioning spring 30 mounted thereon and is similar to the T bolts 24 except

that it has the hand wheel 29 thereon to permit the easy release of the clamping tension of the head 31 against the attaching plate 3 for the purpose of permitting movement or adjustment of the casing 1 and all of the interrupter assemblies 7 in unison for advancing or retarding the entire ignition of the engine. After the tension of the head 31 is released by turning the hand wheel 29, the casing 1 is rotated by means of the handle 32 which is carried thereby.

A suitable indicator, of any approved type, as shown at 33, may be provided for indicating the adjustment of the entire assembly for advancing or retarding the entire ignition of the engine. In the drawings, this indicator 33 comprises a plate 34 carried by the casing 31 and an indicating finger 35 carried by the attaching ring 33.

The outer side or front of the casing 1 is closed by a transparent cover 36, which may be plate glass or any suitable material, and this cover 36 is tightly clamped in place by a clamping ring 37 and clamping screws 38, and it is sealed by suitable sealing gaskets 39. This sealing is desirable, particularly when the spark distributor is used in connection with engines embodying natural or by-product gases as combustible fuel, because in such instances, the air surrounding the engine is usually heavily impregnated with the combustible gas, and it is, of course, undesirable to permit such gas to enter the distributor casing 1. To permit flushing of the interior of the distributor or to provide that the interior of the distributor always has fresh clean air therein, and also to prevent gas impregnated air from entering the casing, the casing 1 has a nipple 40 connected thereon which is adapted to have connection with the air hose to permit air under pressure to be forced into the casing 1. A relief valve 41 of any approved construction is carried by the casing 1 at a point remote from the nipple 40 so as to permit circulation of air through the interior of the casing, and prevent forming of excessive pressure in the casing, while allowing a pressure in excess of atmospheric pressure to be maintained therein.

From the foregoing description, taken in connection with the accompanying drawings, it will be apparent that a spark distributor for use in connection with internal combustion engines has been provided, in which simultaneous operation of a plurality of contactors or of circuit closers is provided by the oscillation of an operating cam, to simultaneously energize a plurality of spark plugs, and also that novel, practical and simple constructions have been developed to provide for independent adjustment of any one or all of the interrupter assemblies, to provide proper balancing between the cylinders, and also means to permit simultaneous adjustment of all of the interrupter assemblies

for advancing or retarding the entire ignition system of the engine.

It will be understood that the invention is not to be limited to the specific construction or arrangement of parts shown but that these may be modified widely within the invention defined by the claims.

What is claimed is:

1. In a spark distributor for ignition systems, a plurality of interrupter assemblies each including make and break contactors, a cam for simultaneously operating the contactors of each interrupter assembly, and means for moving the cams in sequence.

2. In a spark distributor for ignition systems, a plurality of interrupter assemblies each including a plurality of make and break contactors, a cam for simultaneously operating the contactors of each interrupter assembly, means for moving the cams in sequence, and means connected to each cam for reversing the direction of movement of the cam to return it to its normal position after operation of the contactors.

3. In a spark distributor for ignition systems, a plurality of interrupter assemblies each including a plurality of make and break contactors, a cam for simultaneously operating the contactors of each interrupter assembly, means for oscillating the cams in sequence, means for adjusting the position of each interrupter assembly independently of the other interrupter assemblies in the distributor, and means for simultaneously adjusting the positions of all the interrupter assemblies to adjust or retard the entire ignition.

4. In a spark distributor for ignition systems, a plurality of interrupter assemblies each including a plurality of make and break contactors, a cam for simultaneously operating the contactors of each interrupter assembly, means for oscillating the cams in sequence, and means for simultaneously adjusting the positions of all of the interrupter assemblies to advance or retard the entire ignition.

5. The combination with the cam shaft on an internal combustion engine, of an interrupter assembly for the ignition system of the engine including a plurality of make and break contactors, a cam for simultaneously operating said contactors, means carried by the cam shaft for oscillating said cam, and springs for returning said cam to its normal position.

6. The combination with the cam shaft of an internal combustion engine, of a spark distributor including a plurality of interrupter assemblies, each of said assemblies comprising a plurality of make and break contactors, cams for operating said contactors, and means carried by the cam shaft to move said cams for simultaneously operating all the contactors in each interrupter as-

sembly and to move the cams of the various interrupter assemblies in sequence.

7. The combination with the cam shaft of an internal combustion engine, of a spark distributor including a plurality of interrupter assemblies, each of said assemblies comprising make and break contactors, cams for operating said contactors, means carried by the cam shaft to oscillate said cams for simultaneously operating all the contactors in each interrupter assembly and to oscillate the cams of the various interrupter assemblies in sequence, and springs for returning said cams to their normal positions.

8. A spark distributor for an internal combustion engine including a plurality of interrupter assemblies, each of said assemblies comprising make and break contactors, cams for operating said contactors, and means for moving said cams in sequence, each cam upon movement simultaneously operating all the contactors in each interrupter assembly.

9. The combination with the cam shaft of an internal combustion engine, of a spark distributor including a plurality of interrupter assemblies, cams for operating said interrupter assemblies, means carried by the cam shaft for moving said cams in proper sequence, a casing enclosing said spark distributor, and means to permit the flushing of the interior of said casing by air under pressure.

10. A spark distributor for an internal combustion engine including a plurality of interrupter assemblies, each of said assemblies comprising a plurality of make and break contactors, cams for operating said contactors, means for oscillating said cams in sequence, each cam upon oscillation simultaneously operating all the contactors in each interrupter assembly, a casing enclosing said spark distributor, and means on said casing whereby the interior of the casing may be flushed by air under pressure.

11. In a spark distributor for ignition systems, a plurality of interrupter assemblies each including make and break contactors, a cam for simultaneously operating the contactors of each interrupter assembly, means for oscillating the cams in sequence, a casing enclosing said spark distributor, and means on said casing whereby the interior of the casing may be flushed by air under pressure.

12. In a spark distributor for ignition systems, a plurality of interrupter assemblies each including make and break contactors, cams for operating said contactors, a carrying bar for each of said interrupter assemblies, adjustable means for adjusting each of said bars, and means for locking said bars in adjusted positions, whereby each interrupter assembly may be adjusted independently of the other interrupter assemblies in the distributor.

13. In a spark distributor for ignition sys-

- tems, a plurality of interrupter assemblies each including make and break contactors, a cam for operating said contactors, a carrying bar for each of said interrupter assemblies, 5 adjustable means for adjusting each of said bars, means for locking said bars in adjusted positions, whereby each interrupter assembly may be adjusted independently of the other interrupter assemblies in the distributor and means for simultaneously adjusting 10 the positions of all interrupter assemblies to advance or retard the entire ignition.
14. In a spark distributor for ignition systems, a plurality of interrupter assemblies, 15 a casing enclosing said interrupter assemblies, yieldable attaching means carried by said casing, attaching means for locking the casing in attached position, said locking attaching means releasable to permit movement of 20 the casing to simultaneously adjust the positions of all of said interrupter assemblies to advance or retard the entire ignition.
15. In a spark distributor for ignition systems, a plurality of interrupter assemblies, 25 each including a plurality of make and break contactors, a cam for simultaneously operating the contactors of each interrupter assembly, means for oscillating the cams in sequence, a casing enclosing said interrupter 30 assemblies, yieldable attaching means carried by said casing, attaching means for locking the casing in attached position, said locking attaching means releasable to permit movement of the casing to simultaneously adjust 35 the positions of all of said interrupter assemblies relative to said cam oscillating means to advance or retard the entire ignition.
16. In a spark distributor for ignition systems, a plurality of interrupter assemblies, 40 each including make and break contactor, a cam for operating the contactor of each interrupter assembly, means for oscillating the cams in sequence, a carrying bar for each of said interrupter assemblies, adjustable means 45 for adjusting each of said bars to vary the position of each interrupter assembly independently of the other relative to said cam oscillating means.
17. In a spark distributor for ignition systems, a plurality of interrupter assemblies, 50 each including a plurality of make and break contactors, a cam for simultaneously operating the contactors of each interrupter assembly, means for oscillating the cams in sequence, a carrying bar for each of said inter- 55 rupter assemblies, adjustable means for adjusting each of said bars to vary the position of each interrupter assembly independently of the other relative to said cam oscillating means, a casing enclosing said interrupter 60 assemblies, yieldable attaching means carried by said casing, attaching means for locking the casing in attached position, said locking attaching means releasable to permit move- 65 ment of the casing to simultaneously adjust the positions of all of said interrupter assemblies relative to said cam oscillating means.
18. In a spark distributor for ignition systems, a plurality of interrupter assemblies, 70 a carrying bar for each of said interrupter assemblies, adjustable means for adjusting each of said bars to independently adjust the positions of said interrupter assemblies, a casing enclosing said distributor, yieldable 75 attaching means carried by said casing, attaching means for locking the casing in attached position, said locking attaching means releasable to permit movement of the casing to simultaneously adjust the positions of all of said interrupter assemblies. 80
19. In a spark distributor for ignition systems, a plurality of interrupter assemblies each including a make and break contactor, a contactor operating cam in each interrupter 85 assembly, means for moving the cams in sequence, and means connected to each cam to return it to its normal position after operation of the contactors.
20. In a spark distributor for ignition systems, a plurality of interrupter assemblies 90 each including a make and break contactor, a contactor operating cam in each interrupter assembly, means for moving the cams in sequence, and means for adjusting the position 95 of each interrupter assembly independently of the other interrupter assemblies in the distributor.
- In testimony whereof I affix my signature.
HENRY C. LEHN. 100
- 105
110
115
120
125
130