

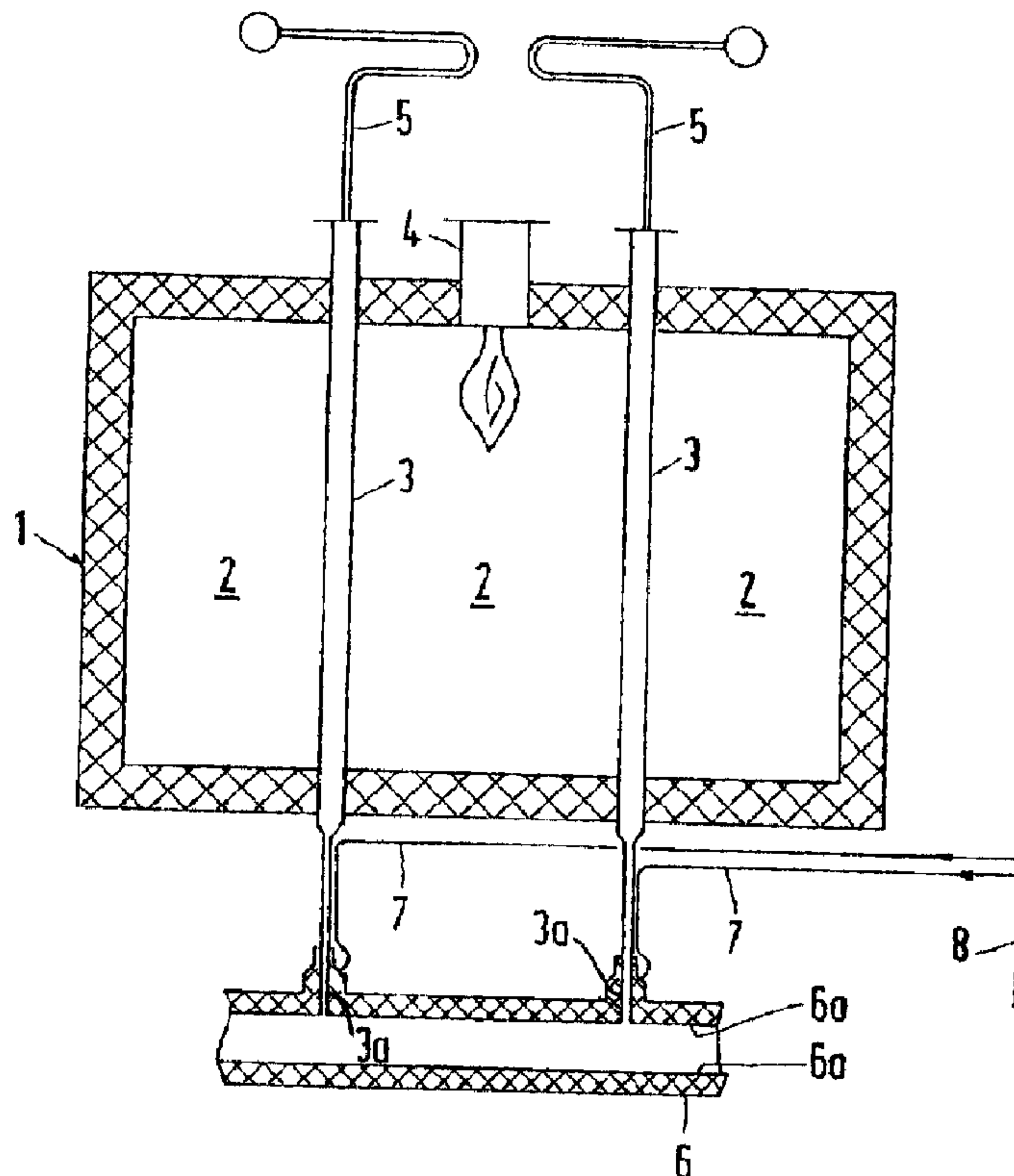

(22) Date de dépôt/Filing Date: 1994/08/02
 (41) Mise à la disp. pub./Open to Public Insp.: 1995/02/14
 (45) Date de délivrance/Issue Date: 2003/12/09
 (30) Priorité/Priority: 1993/08/13 (P 43 27 176.6) DE

(51) Cl.Int.⁵/Int.Cl.⁵ B01J 7/00
 (72) Inventeurs/Inventors:
 HOHMANN, FRIEDRICH, DE;
 ROLL, WERNER, DE;
 MORTEL, HANS GUNTER, DE
 (73) Propriétaire/Owner:
 METALLGESELLSCHAFT AKTIENGESELLSCHAFT,
 DE
 (74) Agent: ROBIC

(54) Titre : APPAREIL DE CHAUFFAGE TUBULAIRE POUR LA PREPARATION DE MELANGES GAZEUX
 CONTENANT DU MONOXYDE DE CARBONE
 (54) Title: TUBULAR HEATER FOR PREPARING CARBON MONOXIDE-CONTAINING GAS MIXTURES



(57) Abrégé/Abstract:

The tubular heater comprises numerous tubes, which are disposed in a combustion chamber and contain catalyst. A synthesis gas, which mainly comprises hydrogen, carbon monoxide, and carbon dioxide, is prepared in the tubes. There is a risk of a formation of carbides (metal dusting corrosion) on the outside surface of the outlet ends of the tubes. To prevent such corrosion, a gaseous or vaporous protecting fluid, which is substantially free of CO, is supplied to the region surrounding the outlet ends of the tubes.

2129303

ABSTRACT

The tubular heater comprises numerous tubes, which are disposed in a combustion chamber and contain catalyst. A synthesis gas, which mainly comprises hydrogen, carbon monoxide, and carbon dioxide, is prepared in the tubes. There is a risk of a formation of carbides (metal dusting corrosion) on the outside surface of the outlet ends of the tubes. To prevent such corrosion, a gaseous or vaporous protecting fluid, which is substantially free of CO, is supplied to the region surrounding the outlet ends of the tubes.

2129303

Tubular Heater for Preparing Carbon Monoxide-containing
Gas Mixtures

DESCRIPTION

This invention relates to a tubular heater for a catalytic cracking of hydrocarbons in order to prepare a raw synthesis gas, which mainly contains hydrogen, carbon monoxide and carbon dioxide, which heater comprises numerous tubes, which are disposed in a combustion chamber and contain catalyst.

Tubular heaters of that kind are known and serve, e.g., for a catalytic cracking of natural gas to prepare a synthesis gas, which is used, e.g., for the synthesis of methanol. Pressures in the range from 1 to 20 bars are usually maintained in the tubes, and the raw synthesis gas has temperatures between 700 and 1000°C at the outlet end of the tubes. It has been found that the outlet end of the tube is subjected to a corrosive action which results in the formation of carbides (metal dusting) and by which the metallic material is destroyed.

It is an object of the invention to effectively protect the tubes at their outlet ends, which are susceptible to metal dusting corrosion, and the region adjacent to such outlet ends. In a tubular heater which is of the kind

described first hereinbefore this is accomplished in accordance with the invention in that means are provided for supplying a gaseous or vaporous protecting fluid which is substantially free of CO to the outside surface of the outlet ends of at least some of the tubes, which outlet ends are disposed outside the combustion chamber and flow through by raw synthesis gas. That protecting fluid prevents a corrosive action of the CO-containing synthesis gas in the particularly susceptible region around the outlet ends of the tubes. In dependence on the CO content the temperature region in which metal dusting corrosion can take place is between about 500 and 850°C.

More particularly, the present invention provides a tubular heater for a catalytic cracking of hydrocarbons in order to prepare a raw synthesis gas which mainly contains hydrogen, carbon monoxide and carbon dioxide, which heater comprises a refractory housing containing a combustion chamber and heating means in the combustion chamber, a plurality of tubes being disposed in the combustion chamber, the tubes containing a catalyst, the catalyst being indirectly heated by the heating means, the tubes having supply means for supplying hydrocarbons and steam into the tubes, the tubes having outlet ends downstream of the catalyst, the outlet ends being disposed outside the combustion chamber and being flow through by raw synthesis gas, the outlet ends being connected to a collecting line for collecting the raw synthesis gas, the outlet ends having an inside surface provided with a porous refractory lining, bell-shaped portions of the collecting line being connected to the outside of at least some of the outlet ends, each of the bell-shaped portions being

2a

provided with a supply line for supplying a gaseous or vaporous protecting fluid which is substantially free of CO to the outside surface of the outlet end of the portion and into the refractory lining.

At least some of the tubes are preferably provided on the outside of their outlet end with a chamber for receiving a protecting fluid. That chamber usually adjoins a refractory lining, which surrounds the outlet end of the tubes.

10 The present invention also concerns the method of producing synthesis gas by the catalytic cracking of hydrocarbons in a tubular heater, which tubular heater comprises a plurality of tubes passing through a combustion chamber, wherein the hydrocarbons are supplied to the inlet of the tubes, the hydrocarbons being converted to synthesis gas as they pass through the tubes, and exiting the outlet ends of the tubes, and wherein a fuel is burned in the combustion chamber to heat the gases passing through the tubes, and wherein the outlet ends of the tubes are
20 disposed outside the combustion chamber, the improvement which comprises protecting the outlet ends of the tubes and the region adjacent thereto from metal dusting corrosion, by providing a gaseous or vaporous protecting fluid, which is substantially free of CO, to the outside surface of the outlet ends of at least some of the tubes.

Details of the design of the tubular heater heater in accordance with the invention will be explained with reference to the drawing, in which:

30 Figure 1 is a schematic horizontal sectional view showing a tubular heater and

2b

Figure 2 is a longitudinal sectional view which shows on a larger scale the outlet end of a tube.

A refractory housing 1 contains a combustion chamber 2, in which numerous vertical tubes 3 are heated

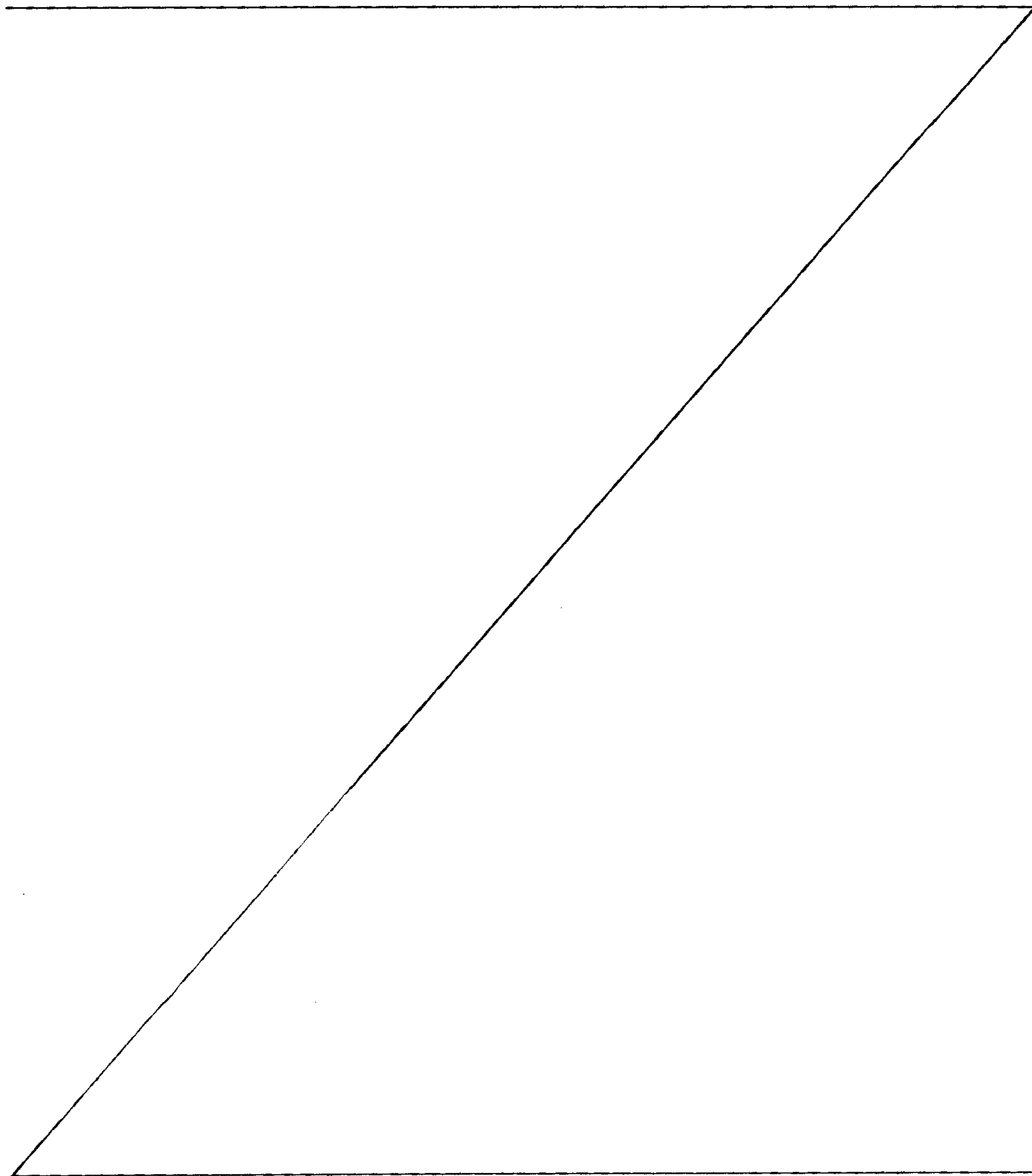

from the outside. Heating is effected by a plurality of burners 4, which are supplied, e.g., with natural gas. A mixture which contains hydrocarbons and steam is supplied through supply lines 5 into the tubes 3 and is reacted in the tubes on the catalyst provided therein and consisting, e.g., of a nickel catalyst. A raw synthesis is thus prepared, which mainly contains hydrogen, carbon monoxide, and carbon dioxide. At temperatures from 700 to 1000°C and preferably of at least 300°C the synthesis gas flows downwardly in the tubes and exits through the outlet ends 3a into a collecting line 6.

It has been found that particularly the outside surfaces of the outlet ends 3a and their environment are susceptible to metal dusting corrosion, which causes the metal to be destroyed by a formation of carbides. Such carbides are formed by the decomposition of carbon monoxide by the reaction $2 \text{CO} \rightarrow \text{CO}_2 + \text{C}$, which is particularly intense at temperatures in the range from 500 to 850°C. Temperatures in that range usually occur on the outside surface of the outlet ends 3a and in their environment.

The collecting line 6 is provided on its inside surface with a refractory lining 6a, which surrounds also the outlet ends 3a of the tubes 3. Because the refractory lining has a certain porosity, synthesis gas must be expected to diffuse through the refractory lining and synthesis gas at relatively low temperatures reaches the outside sur-

face of the outlet ends 3a so that the above-mentioned corrosion takes place.

In order to protect the outlet ends 3a and their closest environment against the corrosive action resulting in a formation of carbides, each outlet end is provided with a supply line 7, through which a gaseous or vaporous protecting fluid is supplied from a main line 8. The protecting fluid may consist, e.g., of hydrogen, water vapor, nitrogen or CO₂.

It is apparent from Figure 2 how the protecting fluid is conducted through the line 7 into a chamber 9, which is disposed within a bell-shaped enlarged portion 10 of the collecting line 6. The enlarged portion 10 is welded at its top end 10a to the tube 3. The protecting fluid prevents the metal dusting corrosion on the outside surface of the outlet end 3a and on the inside surface of the enlarged portion 10.

The refractory lining 6a of the collecting line 6 surrounds the outlet end 3a of the tube 3. The lining 6a consists, e.g., of a rammed composition and is slightly porous so that the protecting fluid can diffuse out of the chamber 9 through the lining and is finally discharged in the collecting line 6 together with the synthesis gas.

As is apparent from Figures 1 and 2 the line 7 which comes from the main line 8 and conducts protecting fluid extends downwardly over a certain distance in contact with the outside surface of the associated tube 3 so that

the hot gas inside the tube 3 is used to heat the protecting fluid in the line 7 by an indirect heat exchange and the protecting fluid is at an elevated temperature as it enters the chamber 9. That heating of the protecting fluid prevents thermal stresses adjacent to the outlet end 3a.

WHAT IS CLAIMED IS:

1. A tubular heater for a catalytic cracking of hydrocarbons in order to prepare a raw synthesis gas which mainly contains hydrogen, carbon monoxide and carbon dioxide, which heater comprises a refractory housing containing a combustion chamber and heating means in said combustion chamber, a plurality of tubes being disposed in said combustion chamber, said tubes containing a catalyst, said catalyst being indirectly heated by said heating
10 means, said tubes having supply means for supplying hydrocarbons and steam into said tubes, said tubes having outlet ends downstream of said catalyst, said outlet ends being disposed outside said combustion chamber and being flown through by raw synthesis gas, said outlet ends being connected to a collecting line for collecting said raw synthesis gas, said outlet ends having an inside surface provided with a porous refractory lining, bell-shaped portions of the collecting line being connected to the outside of at least some of said outlet ends, each of said
20 bell-shaped portions being provided with a supply line for supplying a gaseous or vaporous protecting fluid which is substantially free of CO to the outside surface of the outlet end of said portion and into the refractory lining.

2. A tubular heater according to claim 1, wherein at least some of the tubes are equipped with a chamber on the outside of their outlet ends for receiving said protecting fluid.

3. A tubular heater according to claim 1 or 2, further characterized in that said protecting fluid is

supplied to each of said at least some of the tubes through a line which extends over and along a portion of each, through which said synthesis gas passes and which is in physical contact with the outside surface of said tube.

4. In the method of producing synthesis gas by the catalytic cracking of hydrocarbons in a tubular heater, which tubular heater comprises a plurality of tubes passing through a combustion chamber, wherein the hydrocarbons are supplied to the inlet of said tubes, said hydrocarbons
10 being converted to synthesis gas as they pass through said tubes, and exiting the outlet ends of said tubes, and wherein a fuel is burned in said combustion chamber to heat the gases passing through said tubes, and wherein the outlet ends of said tubes are disposed outside said combustion chamber, the improvement which comprises protecting said outlet ends of said tubes and the region adjacent thereto from metal dusting corrosion, by providing a gaseous or vaporous protecting fluid, which is substantially free of CO, to the outside surface of said
20 outlet ends of at least some of said tubes.

5. The method of claim 4, wherein said protecting fluid is selected from the group consisting of hydrogen, water vapor, nitrogen and CO₂.

6. The method of claim 5, wherein said hydrocarbons are natural gas.

Fig.1

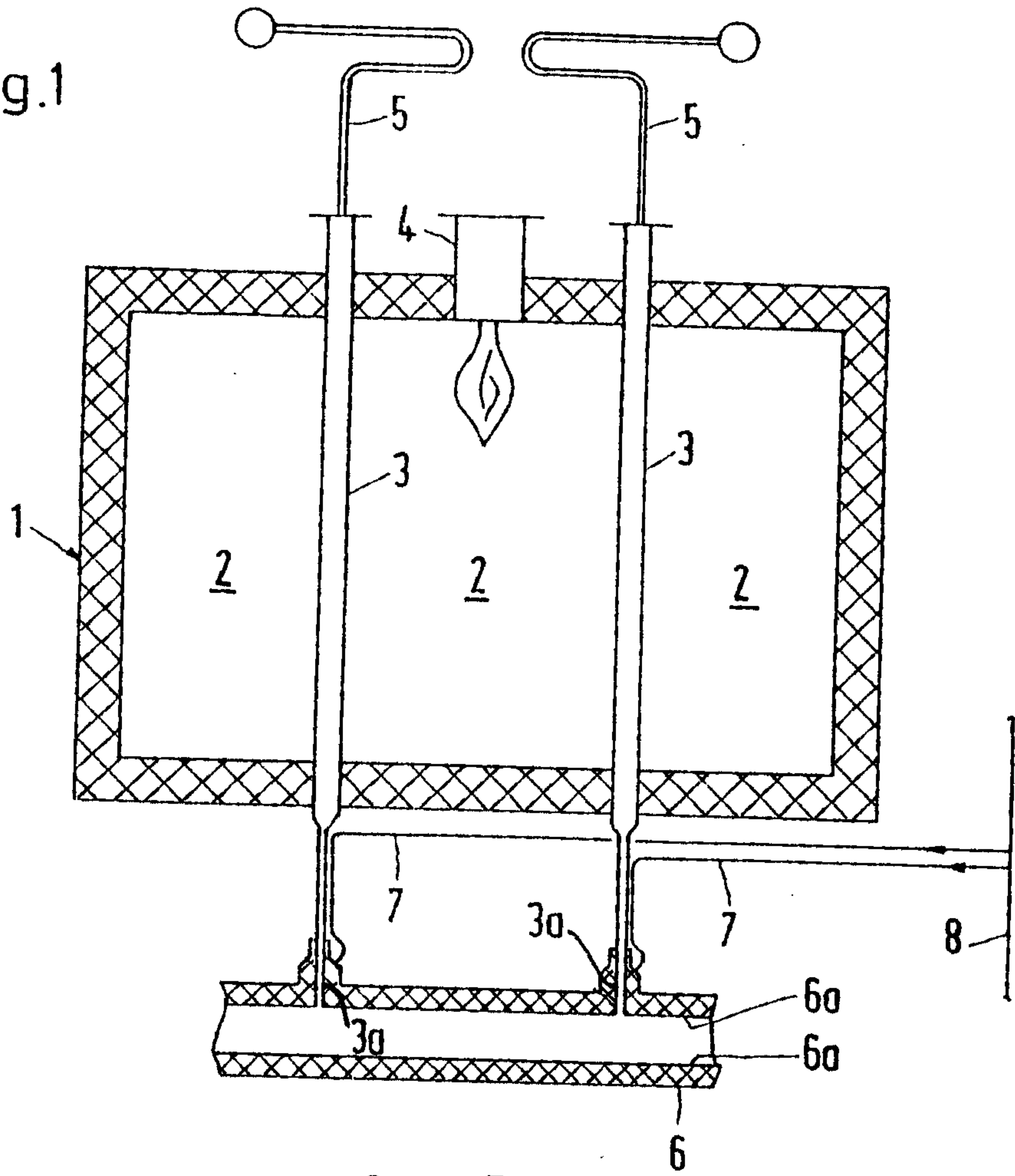

Fig.2

