

(21) Application No 8417358

(22) Date of filing 6 Jul 1984

(30) Priority data

(31) 58/125272 (32) 8 Jul 1983 (33) JP

(71) Applicant
**Kassai Kabushikikaisha (Japan),
 16-1 Higashishimizu-machi, Minami-ku, Osaka-shi,
 Osaka-fu, Japan**

(72) Inventor
Kenzou Kassai

(74) Agent and/or Address for Service
**R. G. C. Jenkins & Co.,
 12-15 Fetter Lane, London EC4A 1PL**

(51) INT CL³
B60T 11/04 7/02 // B62B 9/08

(52) Domestic classification
**F2E 2H9B 3D 3E P S
 B7D 4A
 B7K 4B4
 F2S 502 511 524 CA
 U1S 1827 2013 B7D F2E F2K F2S**

(56) Documents cited
None

(58) Field of search
F2E

(54) **Wheel stopping device**

(57) Two (e.g. rear) wheels of a (collapsible) baby carriage have ribs (46, Figures 9, 10) engaged by respective shafts 27, 27a to establish a wheel stopped state. The shafts 27, 27a are moved by rotation of respective L-levers 28, 28a; rotation of L-lever 28 is brought about by rotation of a (e.g. foot-operated) operating member 25 which also causes a wire 26 to move to rotate L-lever 28a. Torsion (or tension or compression) springs 44, 44a act on levers 28, 28a. The operating member 25 has a pawl 36 which is disengaged from a recess 45 as the member 25 is moved during establishment of a wheel stopped state.

Figures 1-4 show a cushioning mechanism 1 attached to the wheel stopping mechanism 2 at rear leg 3 and comprising a slide portion (14) received in a fixed bracket (6) having a compression spring (24) therein to urge portion (14) downwardly.

FIG. 5

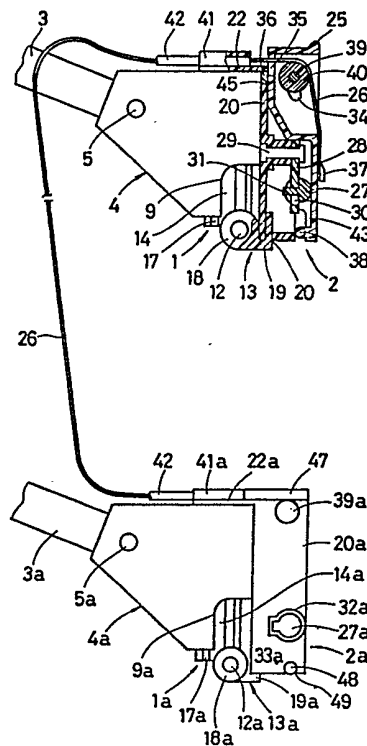

FIG. 14

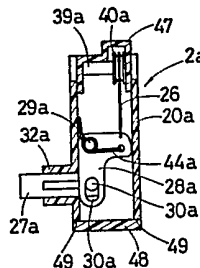

FIG. 1

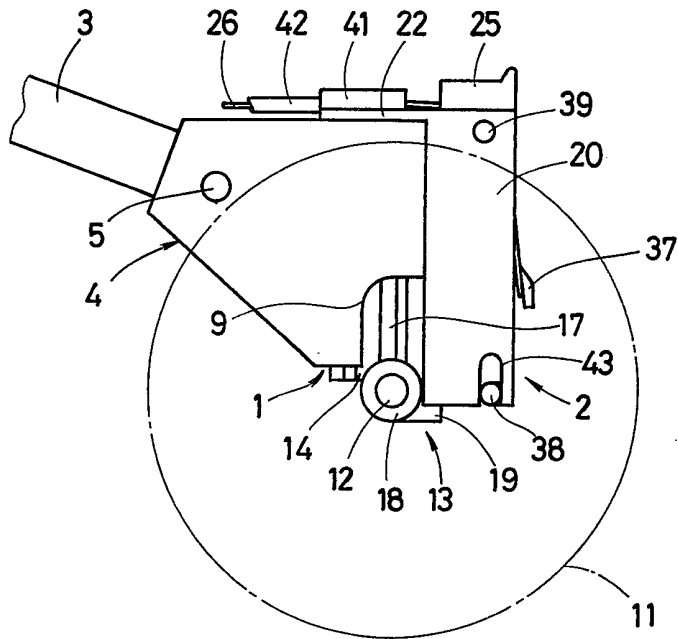

FIG. 2

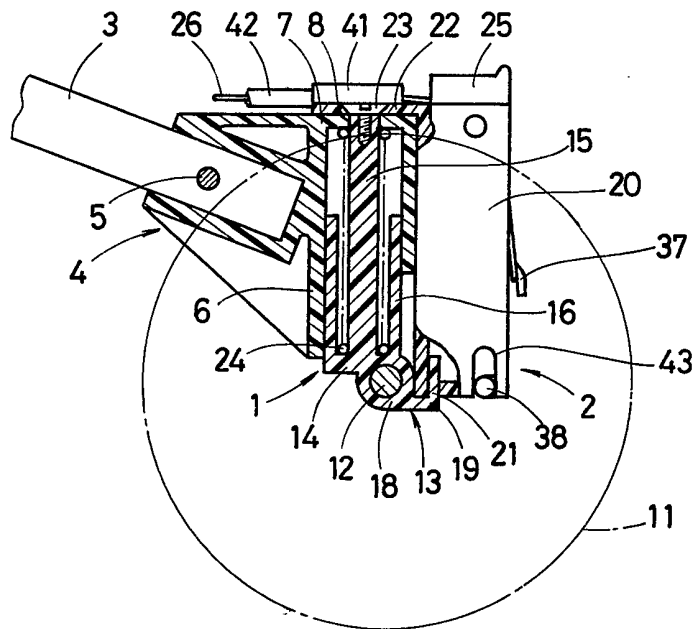

FIG. 3

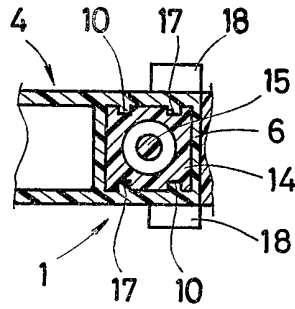

FIG. 4

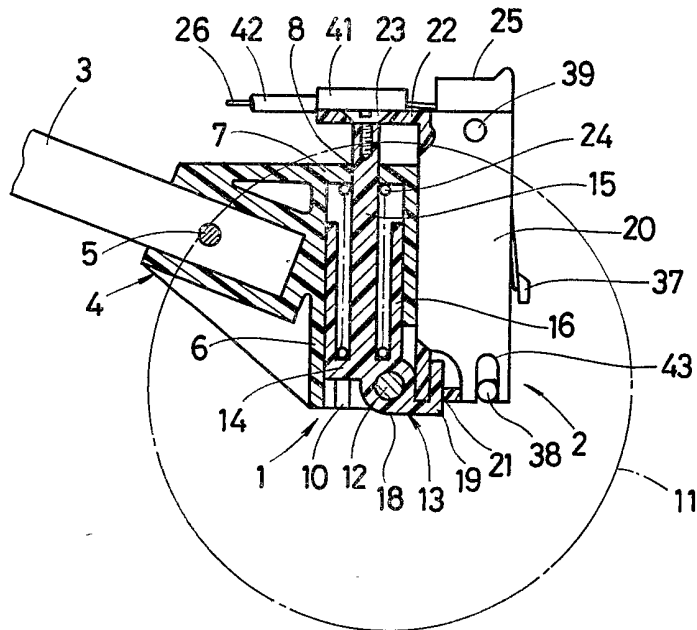

FIG. 5

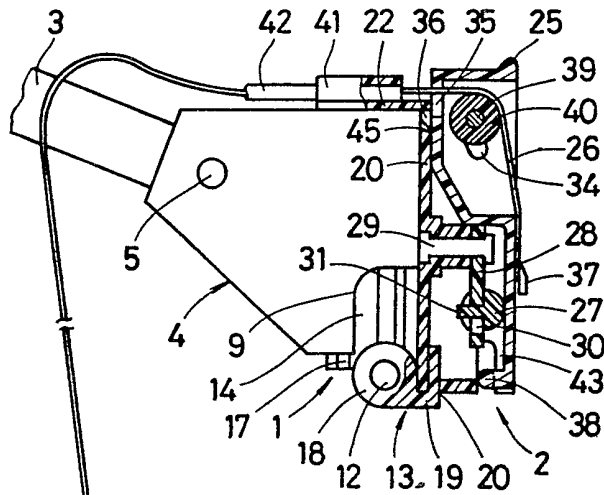

FIG. 6

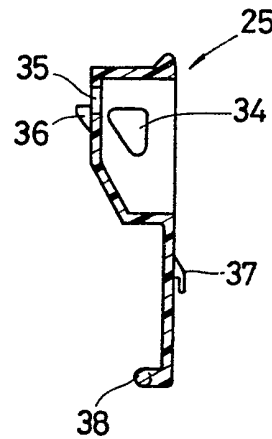

FIG. 7

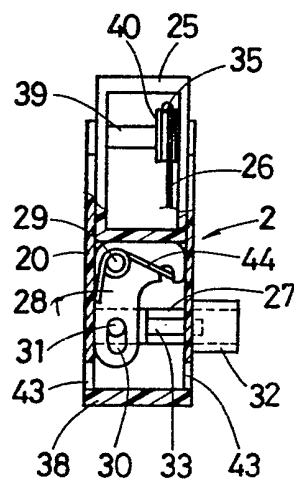
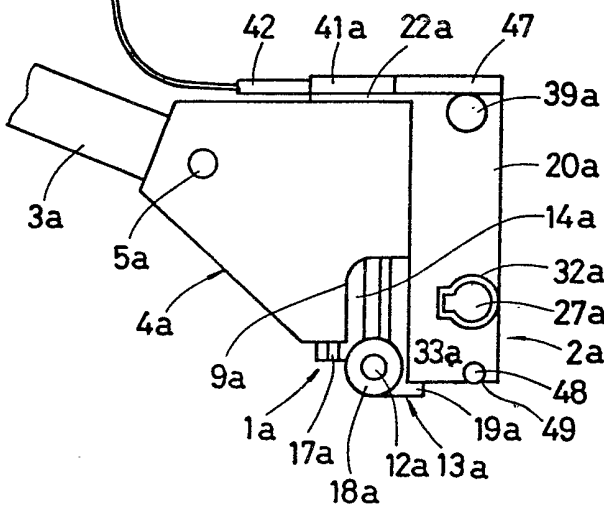

FIG. 9

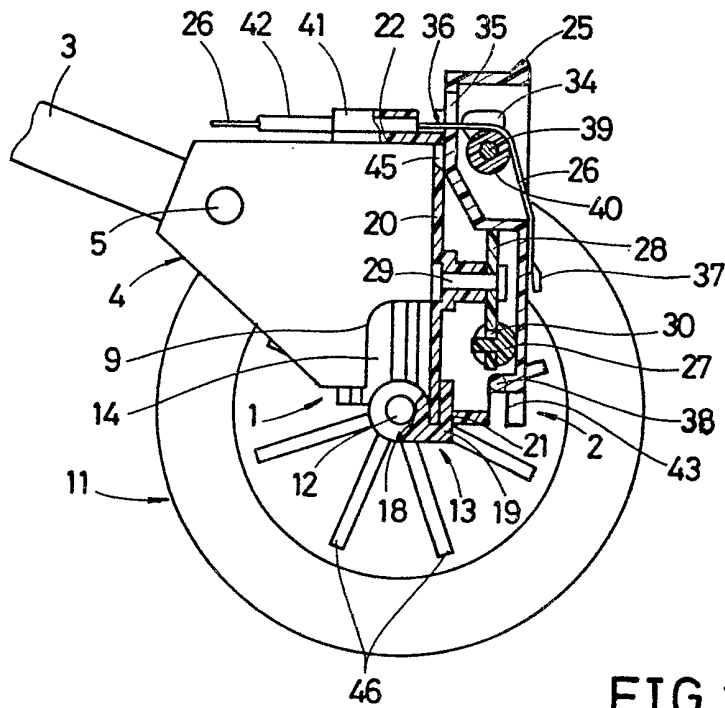

FIG. 8

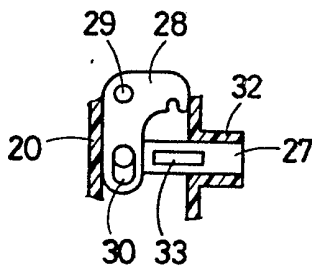

FIG. 10

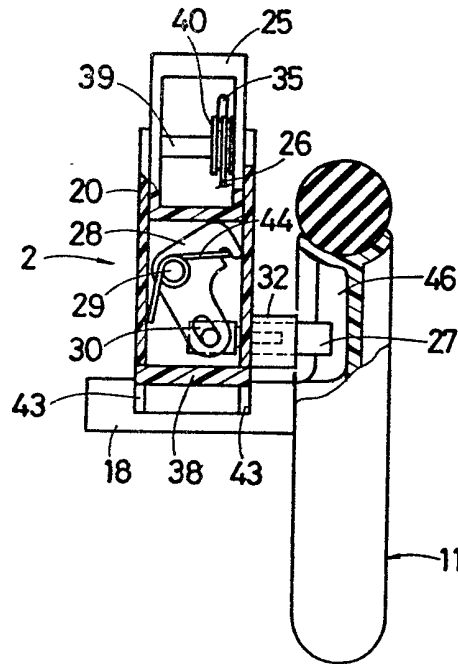

FIG. 11

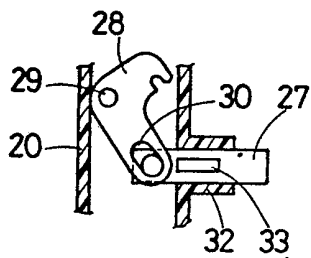

FIG. 12

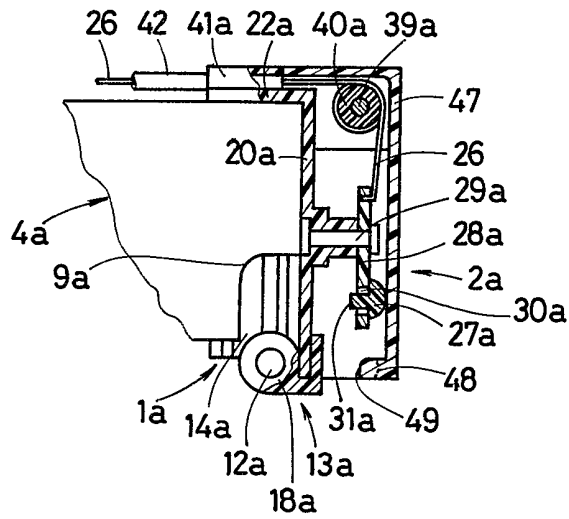

FIG. 13

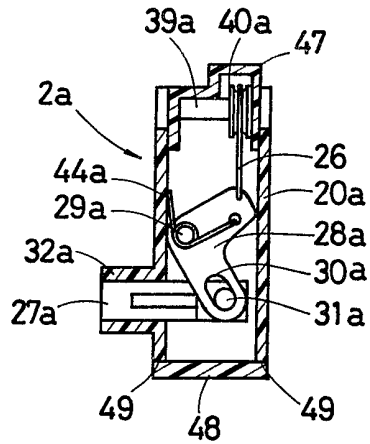

FIG. 14

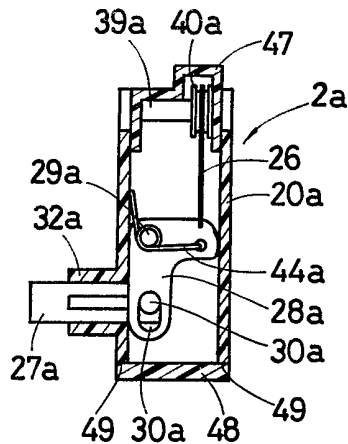
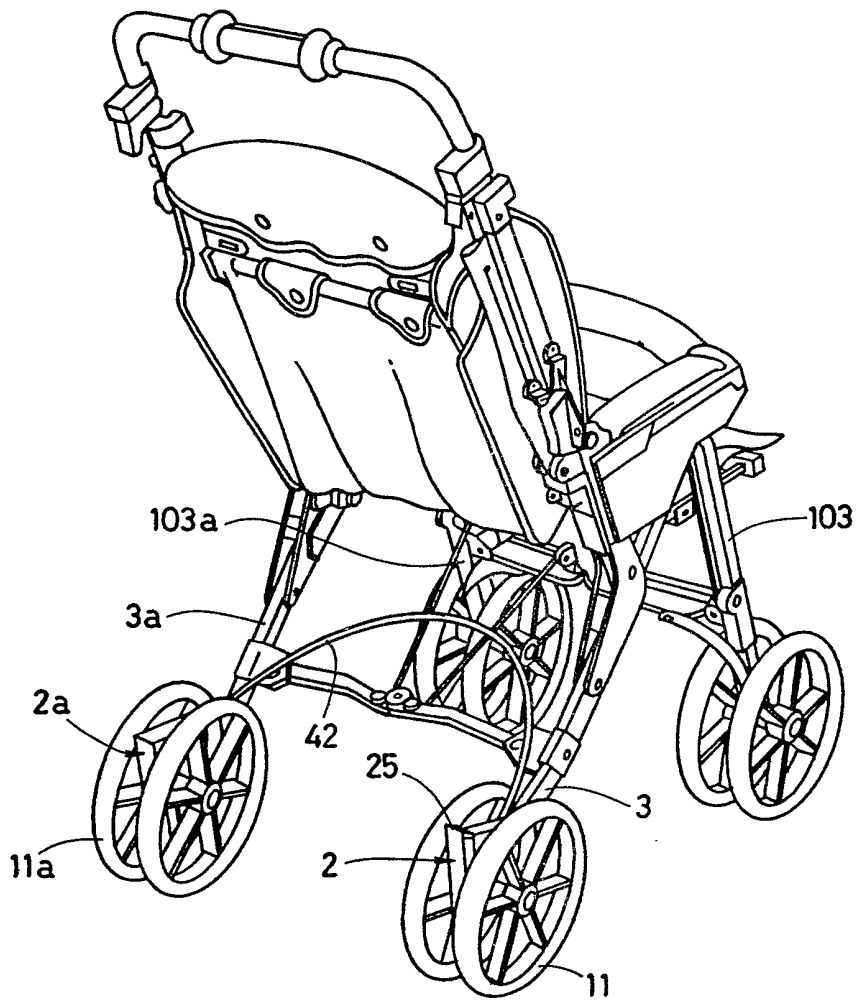

FIG. 15



SPECIFICATION

Wheel stopping device5 *Background of the invention*

This invention relates to a wheel stopping device and particularly to improvements in a wheel stopping device designed to be attached to wheels of a baby carriage, for example, and selectively maintain the stopped state.

A baby carriage, for example, is desirably provided with a wheel stopping device whereby the baby carriage is inhibited from starting to move under its own weight as on a sloping road. It is desired that such wheel stopping device, which is manipulated according to the need, be simple in operation. Further, the wheel stopping device is closely related to the safety of baby carriages, and it is desirable that it be constructed so that with respect to baby carriage wheels disposed at two different places, e.g., right and left rear wheels, the device is capable of maintaining the stopped state of the wheels. This is even a legal obligation in some countries.

In the case where the wheel stopping device is constructed to act on wheels disposed at two different places, it is desirable if two such wheel stopping mechanisms disposed at two places can be simultaneously actuated in one operation. When two wheel stopping mechanisms at two places are to be simultaneously actuated, a solution would be to connect them together by a suitable interlocking mechanism. However, if such wheel stopping device is attached to a collapsible baby carriage, the positional relation between the two wheel stopping mechanisms can change with the collapsing operation. In such case, the interlocking mechanism connecting the two wheel stopping mechanisms can interfere with the collapsing movement of the baby carriage; thus, some measure or other must be taken also for such interlocking mechanism.

Summary of the invention

Accordingly, an object of this invention is to provide a wheel stopping device wherein in the case where two wheel stopping mechanisms are provided at two places, such wheel stopping mechanisms can be simultaneously actuated in one operation and the interlocking mechanism for the two wheel stopping mechanisms does not interfere with the change in the relative positional relation between the two wheels caused by the collapsing movement of a baby carriage or the like.

In this invention, there is employed an arrangement including first and second engaging shafts movable in parallel relation to the respective axes of first and second wheels disposed at two different places, and first and second ribs extending from the respective lateral surfaces of the first and second wheels, wherein when the first and second engaging shafts are moved toward and engage the first and second ribs, respectively, the wheel stopped state is established. Therefore, the wheel rotation permitted state will be obtained as a result of the engaging shafts moving away from the respective ribs. More

particularly, the first and second engaging shafts are connected to one of the respective ends of first and second L-levers rotatably supported at first and second wheel attaching members for attaching the first and second wheels. And an operating member is movably attached to the first wheel attaching member so that it abuts against the other end of the first L-lever, while the first L-lever is provided with a first spring which urges the first L-lever against the operating member. Thereby, with the movement of the operating member, the first L-lever is turned while the first engaging shaft is moved toward and away from the first rib. A wire is used to interlock the two wheel stopping mechanisms. This wire is connected between the operating member and the second L-lever. Thereby, the movement of the operating member is transmitted to the second L-lever, whereby while the second L-lever is turned, the second engaging shaft is moved toward and away from the second rib in synchronism with the first engaging shaft. The second L-lever is provided with a second spring which urges the second L-lever in the direction which imparts tension to the wire.

When the operating member is moved in the direction which turns the first L-lever against the resilience of the first spring, the first engaging shaft is moved away from the first rib, while the force transmitted through the wire turns the second L-lever against the resilience of the second spring, moving the second engaging shaft away from the second rib, whereby the wheel rotation permitted state is established. Since this wheel rotation permitted state must be maintained against the resilience of the second spring, a lock member is provided for locking the operating member to prevent the latter from moving relative to the first wheel attaching member.

On the other hand, when the locking by the lock member is canceled, the first and second engaging shafts are moved toward the first and second ribs by the action of the first and second springs, whereby the wheel stopped state is established.

According to this invention, since the first and second engaging shafts adapted to act on the respective ribs of the first and second wheels are interlocked by a wire through two L-lever and one operating member, by operating the single operating member it is possible to move the first and second engaging shafts in synchronism with each other toward or away from the ribs. Thus, the wheel stopping mechanisms disposed at two places can be simultaneously actuated in a single operation and hence the operations for obtaining the wheel stopped state and the wheel rotation permitted state are facilitated. Further, since the means for connecting the two wheel stopping mechanisms is a wire, there is not possibility of interfering with the change in the relative positional relation between the two wheel stopping mechanisms and hence between the first and second wheels disposed at two different places. Thus, this invention can be advantageously applied to collapsible baby carriages and the like.

According to another aspect of this invention, there is provided a cushioning device for the wheels of a baby carriage.

This cushioning device is characterized by the use of a compression spring which is installed in a state in which it is protected from the outside. More particularly, basically it comprises fixed brackets
 5 fixedly attached to leg members of a baby carriage, cylindrical sections formed as portions of said fixed brackets and defining vertically extending bottom-
 10 opened spaces, wheel attaching members for holding the axles of wheels, slide portions formed as portions of the wheel attaching members and inserted from below into the spaces of the cylindrical sections so that they are vertically slidable, and
 15 coiled compression springs which exert resilient forces between the fixed brackets and the wheel attaching members. And the space of each cylindrical section is closed at its upper end by an upper wall, the latter being formed with a throughgoing hole smaller in cross-section than said space and substantially aligned with the central axis of the space.
 20 The slide portion comprises a central rod adapted to have its upper end received in said throughgoing hole, a box portion formed around said central rod to define therebetween a top-opened bottom-closed space and disposed in contact with the inner
 25 peripheral surface of the cylindrical section, and a stopper for defining the terminal end of the downward movement of the central rod with the upper end of the central rod received in said throughgoing hole, the arrangement being such that when the
 30 central rod is brought to the terminal end position in its downward movement, a clearance of predetermined height allowing cushioning movement is formed between the upper end of the box portion and the lower surface of the upper wall. And said
 35 compression spring is disposed with its lower end positioned between the central rod and the box portion and with its upper end contacting the lower surface of the upper wall.

According to this cushioning device, a compression spring is used and since it is received in the space defined by the cylindrical section and the slide portion, the compression spring is shut off from the outside and hence will not suffer such troubles as rusting and dirt sticking thereto. Therefore, the
 45 cushioning device is long-lived and the cushioning operation is stabilized. Further, since a long compression spring can be used without encountering such problems as aesthetic degradation and fingers being pinched, the cushioning performance can be enhanced even if a thick spring is used. The use of a thick spring, of course, makes it possible to lengthen the life of the device. Further, even if the compression spring should break, this will never lead to a serious accident, since the occurrence of such
 50 breakage is only between the cylindrical section and the slide portion while the latter is supported by the former; thus, the device is superior also in safety. Further, the fixed brackets and the wheel attaching members can be easily made of resin.

Brief description of the drawings

Figure 1 is a side view showing a region around the lower end of the right-hand side rear leg 3 of a baby carriage having an embodiment of the present
 65 invention applied thereto;

Figures 2 through 4 show the construction of a cushioning mechanism 1 formed in combination with a wheel stopping mechanism 2 shown in Figure 1, Figure 2 is a side view showing, in section, the
 70 cushioning mechanism, Figure 3 is a cross-sectional view of the cushioning mechanism 1, and Figure 4 is a partly sectioned side view illustrating the cushioning movement in comparison with Figure 2;

Figure 5 shows a region around the lower end of the left-hand side rear leg 3a along with the region around the lower end of the right-hand side rear leg 3 of Figure 1 and also showing the connection between the right and left wheel stopping mechanisms;

Figure 6 is a vertical sectional view singly showing an operating member 25 shown in Figure 5;

Figure 7 is a partial sectional view as seen from the right-hand side of Figure 5;

Figure 8 is a view showing the connection between a right-hand side engaging shaft 27 and a right-hand side L-lever 28 in Figure 7;

Figure 9 through 11 show the wheel stopped state, Figure 9 corresponds to the upper half of Figure 5, Figure 10 corresponds to Figure 7, and Figure 11 corresponds to Figure 8;

Figures 12 through 14 are sectional views of the left-hand side wheel stopping mechanism 2a, Figure 12 is a view taken from a lateral side, Figure 13 is a view taken from the right-hand side of Figure 12, and
 95 Figure 14 is a view taken from the right-hand side of Figure 12 and showing the wheel stopped state; and

Figure 15 is a perspective view, taken from the rear, of the whole of the baby carriage whose rear legs 3 and 3a are shown in Figures 5, etc.

Description of the preferred embodiments

The wheel stopping device of this invention is applicable to various types of baby carriages and to any other vehicles and the like having wheels at at least two places. In addition, the embodiment to be described below is an application to a baby carriage having two rear legs. Figure 15 shows an example of such baby carriage.

The wheel stopping device of this invention, in a baby carriage having two front legs 103 and 103a and two rear legs 3 and 3a, for example, can be installed in connection with wheels at two places selected from wheels mounted on the right and left front legs 103 and 103a or wheels mounted on the right and left rear legs 3 and 3a. For example, it is applicable to the wheels mounted on the right and left front legs 103 and 103a, the wheels mounted on the right and left rear legs 3 and 3a, and to the wheel mounted on either of the right-hand and left-hand side front legs 103 and 103a and the wheel mounted on either of the right-hand and left-hand side rear legs 3 and 3a. In addition, for the convenience of operation it is preferable to provide the wheel stopping device in connection with the wheels mounted on the rear legs 103 and 103a.

Figures 1 through 4 show a region around the lower end of one rear leg of the baby carriage shown in Figure 15, e.g., the right-hand side rear leg 3. In these figures, a cushioning mechanism 1 installed in connection with the wheel stopping mechanism is
 130

mainly shown, the wheel stopping mechanism 2 being attached to the rear of the cushioning mechanism 1. As for the wheel stopping mechanism 2, only its external appearance is shown, the details of its construction being shown in Figures 5 through 14 to be later described.

A fixed bracket 4 molded of resin is attached to the lower end of the right-hand side rear leg 3 by a fixing pin 5. The rear of the fixed bracket 4 is formed with a vertically extending cylindrical section 6. The cross-sectional shape of the inner surface of the cylindrical section 6, as shown in figure 3, is substantially square. The upper end of the cylindrical section 6 is closed by an upper wall 7 formed with a through-going hole 8. The lower end of the cylindrical section 6 is completely opened. And the rear lower portion of the cylindrical section 6 is formed with a notch 9. Further, the inner surface of the cylindrical section 6, as shown in Figure 3, is formed with a plurality of ridges 10.

The right-hand side rear wheel 11 shown in a dash-dot line in Figures 1, 2, and 4 is the outer one of the two wheels attached to the rear leg 3 shown in Figure 15. These two wheels are rotatably supported on an axle 12, but the inner one is omitted from illustration except in Figure 15. The axle 12 is held by a right-hand side wheel attaching member 13. The right-hand side wheel attaching member 13, which is molded of resin, is formed in two separate portions which are subsequently put together. That is, the front portion of the right-hand side wheel attaching member 13 forms a slide portion for imparting a cushioning action. The axle 12 is positioned on the slide portion 14. The slide portion 14 has a portion received in the cylindrical section 6 of said fixed bracket 4, said portion having a central rod 15 of circular cross-section, and a box portion 16 formed therearound, with a cylindrical space defined therebetween. The height of the central rod 15 is so selected that it is received in the throughgoing hole 8. The height of the box portion 16 is so selected that it forms a clearance of predetermined height between it and the upper wall 7 of the fixed bracket 4. This height allows the cushioning action. The outer peripheral surface of the box portion 16 is similar in shape to the inner surface of the cylindrical section 6 and is formed with vertically extending grooves 17 for receiving the ridges 10. The slide portion 14 is formed with a boss 18 projecting therefrom for receiving the axle 12 therein. The aforesaid notch 9 is provided for enabling the boss portion 18 to avoid interfering with the vertical movement of the slide portion 14. There is provided an L-shaped engaging piece 19 rearwardly extending from the lower end of the boss 18 of the slide portion 14.

The rear portion of the right-hand side attaching member 13 is composed of a holding case 20 for holding the wheel stopping mechanism 2. The holding case 20 is mechanically integrated with the slide portion 14 in that its groove 21 formed in the bottom receives said engaging piece 19 while its attaching piece 22 extending forwardly from the upper end thereof is fixed to the upper end of said central rod 15 by a screw 23. The construction of the wheel stopping mechanism installed in connection

with the holding case 20 will be later described with reference to Figures 5 et seq.

A compression spring 24 is disposed in the cylindrical section 6 of said fixed bracket 4 as it is positioned between the central rod 15 of the slide portion 14 and the box portion 16. The compression spring 24 serves to constantly downwardly urge the slide portion 14 and hence the right-hand side wheel attaching member 13 with respect to the fixed bracket 4, the terminal end of the downward movement thereof being defined by the attaching piece 22 on the holding case 20 abutting against the upper wall 7 of the fixed bracket 4.

The case shown in Figures 1 and 2 is where there is no compression force acting between the right-hand side rear wheel 11 and the right-hand side rear leg 3 or where a compression force acting therebetween is overcome by the resilient force of the compression spring 24; in this case, the attaching piece 22 is abutting against the upper wall 7 and the structure including the right-hand side rear wheel 11, axle 12 and right-hand side wheel attaching member 13 is placed at the lowermost position relative to the structure including the right-hand side rear leg 3 and fixed bracket 4.

Figure 4 shows a state where a force enough to compress the compression spring 24 is applied from the right-hand side rear wheel 11 to the right-hand side rear leg 3 and where the structure including the right-hand side rear wheel 11, axle 12 and right-hand side wheel attaching member 13 has been moved upwardly relative to the structure including the right-hand side rear leg 3 and fixed bracket 4. Thus, the movement produced between the state shown in Figures 1 and 2 and the state shown in Figure 4 brings about a cushioning action.

The wheel stopping device forming the essence of this invention will now be described.

Figure 5 shows the construction associated with the right-hand side rear leg 3 described above and also shows the construction associated with the left-hand side rear leg 3a. The construction associated with the right-hand side rear leg 3 is shown in Figures 6 through 11 and the construction associated with the left-hand side rear leg 3a is shown in Figures 12 through 14.

A brief outline will be described with reference to Figure 5. An operating member 25 is provided on the side associated with the right-hand side rear leg 3, and the right and left wheel stopping mechanisms are interlocked by a wire 26 adapted to be operated by moving said operating member 25.

Figures 5, 7, and 8 show the wheel rotation permitted state. Figure 5 is a partially sectioned side view; Figure 7 is a partially sectioned view taken from the rear; and Figure 8 shows a state where the right-hand side engaging shaft 27 is combined with the right-hand side L-lever 28. Figures 9 through 11 show the wheel stopped state. Figure 9 corresponds to Figure 5; Figure 10 corresponds to Figure 7; and Figure 11 corresponds to Figure 8.

The holding case 20 forming part of the aforesaid right-hand side wheel attaching member 13 is provided with a pin 29 on which the right-hand side L-lever 28 is turnably supported. One end of the

right-hand side L-lever 28 is formed with an elongated opening 30 which receives a connecting pin 31 projecting from the end of the right-hand side engaging shaft 27. The right-hand side engaging shaft 27 is received in a sleeve 32 formed on the holding case 20 and is held so that it is movable in a direction parallel to the axle 12. The right-hand side engaging shaft 27 is formed with a ridge 33 extending lengthwise thereof, while the sleeve 32 is formed with a groove (not shown) extending throughout the length of the sleeve 32 to receive said ridge 33. This arrangement can be known, in Figure 5, by the configurations of the projection 33a on the left-hand side engaging shaft 27 and the left-hand side sleeve 32a, which are structural components on the left-hand side. The formation of the ridges 33 and 33a on the engaging shafts 27 and 27a and the grooves in the sleeves 32 and 32a for receiving them, is intended to enable the engaging shafts 27 and 27a to move stably in the sleeves 32 and 32a.

The operating member 25 is installed so that it contacts the other end of the right-hand side L-lever 28. The operating member 25, as singly shown in a sectional view in Figure 6, is formed with a box-like portion in the upper region thereof. The opposite lateral walls of the box-like portion are formed with substantially triangular guide holes 34. Further, the front wall of the box-like portion is formed with a vertically extending relatively long insertion port 35 for passing the wire 26 therethrough. And a locking pawl 36 is formed which projects forwardly of the front wall of the box-like portion. On the other hand, the lower portion of the operating member 25 is provided with a hook 37 for fixing the end of the wire 26. And the lower end of the operating member 25 is formed with a guide shaft 38 laterally projecting in opposite directions.

The operating member 25 is installed as it is held between the opposite lateral walls of the holding case 20. In this state, a shaft 39 extending through the guide holes 34 formed in the opposite lateral walls of the box-like portion of the operating member 25 is installed to span the space between the opposite lateral walls of the holding case 20. A pulley 40 is rotatably supported on the shaft 39 and the wire 26 is entrained around the pulley 40. The wire 26 extends through a sleeve 41 formed on the aforesaid attaching piece 22. The wire 26 coming out of the sleeve 41 is preferably covered with a flexible tube 42. The end of the flexible tube 42 is inserted into the sleeve 41, where it is fixed.

As shown in Figures 1 etc. described above, the lower end of the holding case 20 is formed with a vertically extending guide cuts 43 in which the respective ends of the guide shaft 38 of the operating member 25 are vertically movably received. Thus, the operating member 25 are vertically movably received. Thus, the operating member 25 is movably relative to the holding case 20 by an amount corresponding to the range in which the guide holes 34 with the shaft 39 received therein is movable and the range in which the guide shaft 38 are movable in the guide cuts 43.

The aforesaid right-hand side L-lever 28 is urged by a right-hand side torsion spring 44 to abut against

the operating member 25. The right-hand side torsion spring 44 is held on the pin 29 and engaged at its ends respectively with the holding case 20 and the other end of the right-hand side L-lever 28.

Therefore, the right-hand side L-lever 28, in Figure 7, is urged to turn counterclockwise around the axis of the pin 29, constantly applying an upward force to the operating member 25. In order to maintain the operating member 25 in the lower position despite such force, the holding case 20 is formed with a locking recess 45 adapted to receive the aforesaid pawl 36, as shown in Figure 9.

In Figures 9 and 10, the details of the right-hand side rear wheel 11 are shown. The right-hand side rear wheel 11 is provided with a plurality of right-hand side ribs 46 projecting from the lateral surface thereof. As shown in Figure 10, when the right-hand side engaging shaft 27 is moved toward the right-hand side ribs 46, the state where it engages a right-hand side rib 46 is established.

As shown in the lower half of Figure 5, the left-hand side wheel stopping mechanism 2a is not provided with a member corresponding to the operating member 25. Thus, the left-hand side wheel stopping mechanism 2a is correspondingly simple in arrangement. In addition, in describing the arrangement on the left-hand side, the elements corresponding to those included in the right-hand side arrangement are denoted by the same reference numerals as used in the description of the right-hand side arrangement, plus the letter "a" and only those parts which differ will be described while avoiding repeating the same description.

The wire 26 extending from the right-hand side wheel stopping mechanism 2, as shown in Figures 12 through 14, is directly connected to the left-hand side L-lever 28a in the left-hand side wheel stopping mechanism 2a. A left-hand side torsion spring 44a is installed so that the left-hand side L-lever 28a is rotated in the direction to impart tension to the wire 26. That is, the left-hand side torsion spring 44a is held on the pin 29a, with its ends respectively engaging the holding case 20a and the left-hand side L-lever 28a. No operating member is provided on the left-hand side and instead a cover 47 is fitted in the holding case 20a. The lower end of the cover 47 is formed with a shaft 48 laterally projecting in opposite directions. The respective ends of the shaft 48 are received in the cuts 49 formed in the lower end of the holding case 20a while the shaft 39a extends through the opposite lateral walls of the cover 47, whereby the cover 47 is fixed to the holding case 20a.

Referring to all the figures that have been mentioned so far, a description will now be given of the method of operating the wheel stopping device and the resulting movements of parts.

Figures 5, 7, 8, 12, and 13 show the wheel rotation permitted state. In this state, the right-hand and left-hand side engaging shafts 27 and 27a are not projecting out of the sleeves 32 and 32a and hence they are not engaged with ribs formed on the rear wheels, e.g., ribs 46. This state is established by resisting the resilient forces of the right-hand and left-hand side torsion springs 44 and 44a, and in

order to maintain this state, the locking pawl 36 of the operating member 25 is engaged in the locking recess 45 of the right-hand side wheel attaching member 13. In this state, the wire 26, which is given
5 a tension by the action of the left-hand side torsion spring 44a, is applying a pushing force, to the left as viewed in Figure 5, to the operating member 25; thus, the locking pawl 36 will not be disengaged from the locking recess 45 unless an external force is
10 applied thereto.

To change the aforesaid wheel rotation permitted state into the wheel stopped state, the operator puts, for example, this foot on the upper surface of the operating member 25 and moves it to the rear (to the
15 right as viewed in Figure 5). In response thereto, the operating member 25 is moved by an amount corresponding to the range in which the shaft 39 can horizontally move within the guide holes 34. In response thereto, the locking pawl 36 comes out of the locking recess 45. Then, since the right-hand side
20 torsion spring 44 is pushing up the operating member 25 through the right-hand side L-lever 28 while, at the same time, the left-hand side torsion spring 44a is applying tension to the wire 26 and since this tension of the wire 26 acts upwardly at the end of the wire 26 because of the presence of the pulley 40, this force results in the operating member 25 being pulled up, whereby the locking pawl 36 is disengaged from the locking recess 45; thus, as soon
25 as the foot placed on the operating member 25 is removed, the operating member 25 is upwardly moved, so that the state shown in Figures 9 and 10 is established. Consequently, as shown in Figures 10 and 11, the right-hand side L-lever 28 is rotated
35 following the movement of the operating member 25, so that the right-hand side engaging shaft 27 connected to one end thereof is projected out of the sleeve 32. In this state, as shown in Figure 10, the right-hand side engaging shaft 27 becomes engaged
40 with the rib 46, putting the right-hand side rear wheel 11 in the wheel stopped state.

On the other hand, in the left-hand side region, the aforesaid upward movement of the operating member 25 causes the wire 26 to move a predetermined
45 distance toward the left-hand side wheel stopping mechanism 2a. At this time, since the wire has a tension constantly applied thereto by the left-hand side torsion spring 44a, the left-hand side L-lever 28 is rotated following the movement of the wire 26,
50 thus projecting the left-hand side engaging shaft 27a out of the sleeve 32a. Although the left-hand side rear wheel is omitted in the figure showing the left-hand side, it will be seen that when the left-hand side engaging shaft 27a is projected in this manner,
55 it engages the rib on the left-hand side wheel; thus, the wheel stopped state is established here also. In addition, the left-hand side rear wheel described herein may be understood to be the wheel indicated by 11a in Figure 15.

To change such wheel stopped state back into the wheel rotation permitted state, it is only necessary to downwardly push in the operating member 25. In response thereto, the locking pawl 36 engages the locking recess 45, whereupon the aforesaid wheel
60 rotation permitted state is obtained.
65

While the invention has so far been described with reference to a particular embodiment thereof, this embodiment may be modified at various portions thereof.

70 For example, the torsion springs 44 and 44a provided to the L-levers 28 and 28a may be replaced by tension springs or compression springs.

While the operating members 25 has been designed so that in its movement, at least the upper
75 portion thereof is movable not only up and down but also back and forth, it may be so designed that it is movable only up and down. In this case, the shape of the locking means made up of the locking pawl 36 and locking recess 45 would have to be more or less
80 changed. For example, it would be necessary to reduce the extent of projection of the member corresponding to the locking pawl or to provide an elastically deformable portion in this locking portion.

Further, while the aforesaid embodiment has been
85 provides with cushioning mechanisms 1 and 1a, such cushioning mechanisms are not essential, and the wheel attaching member and the rear leg may be fixedly connected together.

Further, while this invention is advantageously
90 applicable to collapsible baby carriages and the like, it is, of course, applicable also to baby carriages and the like having no such collapsing function.

Although the present invention has been described and illustrated in detail, it is clearly understood that the same is by way of illustration and example only and is not to be taken by way of limitation, the scope of the present invention being limited only by the terms of the appended claims.
95

100 CLAIMS

1. A wheel stopping device including first and second engaging shafts (27, 27a) movable parallelly to the axles (12, 12a) of first and second wheels (11, 11a) disposed at two different places, and first and second ribs (46) projecting from the lateral surfaces of said first and second wheels (11, 11a), wherein when said first engaging shaft (27) is moved toward said first rib (46) and engages the latter to thereby
105 establish the wheel stopped state, in operative association therewith said second engaging shaft (27a) is also moved toward said second rib and engages the latter to thereby establish the wheel stopped state, while, on the other hand, when said first engaging shaft (27) returns to its original state to thereby establish the wheel rotation permitted state, in operative association therewith said second engaging shaft (27a) also returns to its original state to thereby establish the wheel rotation permitted state, said wheel stopping device being characterized in that:
110

said first and second engaging shafts (27, 27a) are connected to one of the respective ends of first and second L-levers (28, 28a) rotatably supported by first and second wheel attaching members (13, 13a) for attaching said first and second wheels (11, 11a), respectively,
115

an operating member (25) is movably attached to said first wheel attaching member (13) so that it abuts against the other end of said first L-lever (28),
120
125
130

while a first spring (44) is provided to said first L-lever (28) to urge the latter against said operating member (25), whereby with the movement of said operating member (25) and attended by the rotation of said first L-lever (28), said first engaging shaft (27) is moved toward and away from said first rib 46, a wire (26) is connected between said operating member (25) and said second L-lever (28a), whereby the movement of said operating member (25) is transmitted to the second L-lever (28a), whereby with the rotation of the second L-lever (28a) and in synchronism with said first engaging shaft (27), said second engaging shaft (27a) is moved toward and away from said second rib,

15 a second spring (44a) is provided to said second L-lever (28a) to urge the latter to rotate in the direction in which the second L-lever (28a) imparts tension to said wire (26),

when said operating member (25) is moved in the direction to rotate said first L-lever (28) against the resilience of said first spring (44), said first engaging shaft (27) is moved away from said first rib (46) while the force transmitted through said wire (26) rotates said second L-lever (28a) against the resilience of said second spring (44a) so as to move said second engaging shaft (27a) away from said second rib, whereby establishing said wheel rotation permitted state, to maintain this state against the resilient forces of said first and second springs (44, 44a) there being provided locking members (36, 45) for locking said operating member (25) to prevent the latter from moving relative to said first wheel attaching member (13),

on the other hand, when the locking by said locking members (36, 45) is canceled, the actions of said first and second springs (44, 44a) cause said first and second engaging shafts (27, 27a) to move toward said first and second ribs (46), thereby establishing said wheel stopped state.

2. A wheel stopping device as set forth in Claim 1, wherein said first and second springs (44, 44a) are torsion springs.

3. A wheel stopping device as set forth in Claim 1, wherein said wire (26) is inserted in a flexible tube (42) fixed at its ends to the first and second wheel attaching members (13, 13a).

4. A wheel stopping device as set forth in Claim 1, wherein said first and second wheel attaching members (13, 13a) are respectively provided with sleeves (32, 32a) for guiding the movement of said first and second engaging shafts (27, 27a).

5. A wheel stopping device as set forth in Claim 4, wherein said first and second engaging shafts (27, 27a) are respectively formed with axially extending ridges (33, 33a), while said sleeves (33, 33a) are formed with grooves (32, 32a) for receiving said ridges (33, 33a).

6. A wheel stopping device as set forth in Claim 1, wherein said operating member (25) is provided with guide shafts (38) laterally extending therefrom and guide holes (34) laterally extending there-through, while said first wheel attaching member (13) is formed with guide cuts (43) for operatively receiving said guide shafts (38) and with a shaft (39) laterally extending through said guide holes (34),

whereby

said operating member is movable relative to said first wheel attaching member (13) by an amount corresponding to the range in which said guide holes (34) with said shaft (39) received therein is movable and the range in which said guide shaft (34) is movable within said guide cuts (43).

7. A wheel stopping device as set forth in Claim 6, wherein said shaft (39) rotatably carries a pulley (40) thereon, said wire being entrained around said pulley (40).

8. A wheel stopping device as set forth in Claim 1, wherein the tension imparted to said wire acts on said operating member (25) in the direction to maintain the locked state of said locking members (36, 45).

9. A wheel stopping device as set forth in Claim 1, wherein said wheel stopping device is applied to the wheels (11, 11a) respectively attached to the two leg members (3, 3a) included in the baby carriage.

10. A wheel stopping device as set forth in Claim 9, further including:

fixed brackets (4, 4a) fixedly attached to the leg members (3, 3a) of the baby carriage,

cylindrical sections (6) formed as portions of said fixed brackets (4, 4a) to define vertically extending bottom-opened spaces,

slide portions (14) formed as portions of said wheel attaching members (13, 13a), inserted from below into the spaces of said cylindrical section (6), and vertically slidable,

coiled compression springs (24) for exerting resilient forces between said fixed brackets (4, 4a) and said wheel attaching members (13, 13a),

the space of each cylindrical section (6) being closed at its upper end by an upper wall (7) formed with a throughgoing hole (8) smaller in cross-section than said space and substantially aligned with the central axis,

said slide portion (14) comprising a central rod (15) having its upper end received in said throughgoing hole (8), a box portion (16) formed around said central rod (15) to define therebetween a top-opened bottom-closed space and contacted with the inner peripheral surface of said cylindrical section (6), and a stopper (22) for defining the terminal end of the downward movement of said central rod (15) with the upper end of the central rod (15) received in said throughgoing hole (8), wherein when said central rod (15) is brought to the terminal position of its downward movement, a clearance of predetermined height allowing the cushioning action is formed between the upper end of said box portion (16) and the lower surface of said upper wall (7),

each said compression spring (24) having its lower end positioned between said central rod (15) and said box portion (16) and its upper end contacted with the lower surface of said upper wall (7).

11. A wheel stopping device as set forth in Claim 10, wherein the outer peripheral surface of the box portion (16) of said slide portion (4) and the inner peripheral surface of said cylindrical section (6) are formed with ridges (10) and grooves (17) which form pairs and extend vertically.

12. A product having two wheels wherein the

positional relation between the wheels is selectively changeable and wherein means are provided for locking the wheels against rotation, the locking means for both wheels being actuatable by a single
5 operating member.

13. A mechanism for locking a plurality of wheels, whose positional relation relative to one another is selectively changeable, against rotation, which mechanism includes a plurality of locking
10 devices each associated with a respective wheel, and a single operating member for operating all the locking devices.

14. A mechanism substantially as herein particularly described with reference to and as illustrated in
15 the accompany drawings.