



- (51) International Patent Classification:
H04W 72/04 (2009.01)
- (21) International Application Number:
PCT/CN2013/071191
- (22) International Filing Date:
31 January 2013 (31.01.2013)
- (25) Filing Language: English
- (26) Publication Language: English
- (71) Applicant: TELEFONAKTIEBOLAGET L M ERICSSON (PUBL) [SE/SE]; S-164 83 Stockholm (SE).
- (72) Inventor; and
- (71) Applicant (for SC only): SONG, Xinghua [CN/CN]; Ericsson Tower, No.5 Lize East Street, Chaoyang District, Beijing 100102 (CN).
- (72) Inventors: FAN, Rui; No 5, Lize East Street, Chaoyang District, Beijing 100102 (CN). LI, Shaohua; B83-1-502,

Lingxiuxingguigu, Xierqi, Haidian district, Beijing 100085 (CN). LU, Qianxi; Nanhuxiyuan 226, Room 2-101, Chaoyang District, Beijing 100102 (CN). ZHANG, Hao-chuan; Ericsson Tower, No. 5 Lize East Street, Chaoyang District, Beijing 100102 (CN).

(74) Agent: CHINA SCIENCE PATENT & TRADEMARK AGENT LTD.; 11/F., Bldg. D, International Finance and Economics Center, No.87, West 3rd Ring North Rd., Haidian District, Beijing 100089 (CN).

(81) Designated States (unless otherwise indicated, for every kind of national protection available): AE, AG, AL, AM, AO, AT, AU, AZ, BA, BB, BG, BH, BN, BR, BW, BY, BZ, CA, CH, CL, CN, CO, CR, CU, CZ, DE, DK, DM, DO, DZ, EC, EE, EG, ES, FI, GB, GD, GE, GH, GM, GT, HN, HR, HU, ID, IL, IN, IS, JP, KE, KG, KM, KN, KP, KR, KZ, LA, LC, LK, LR, LS, LT, LU, LY, MA, MD, ME, MG, MK, MN, MW, MX, MY, MZ, NA, NG, NI, NO, NZ, OM, PA, PE, PG, PH, PL, PT, QA, RO, RS, RU, RW, SC, SD, SE, SG, SK, SL, SM, ST, SV, SY, TH, TJ,

[Continued on next page]

(54) Title: TDM-BASED RESOURCE PARTITION BETWEEN TWO RADIO BASE STATIONS

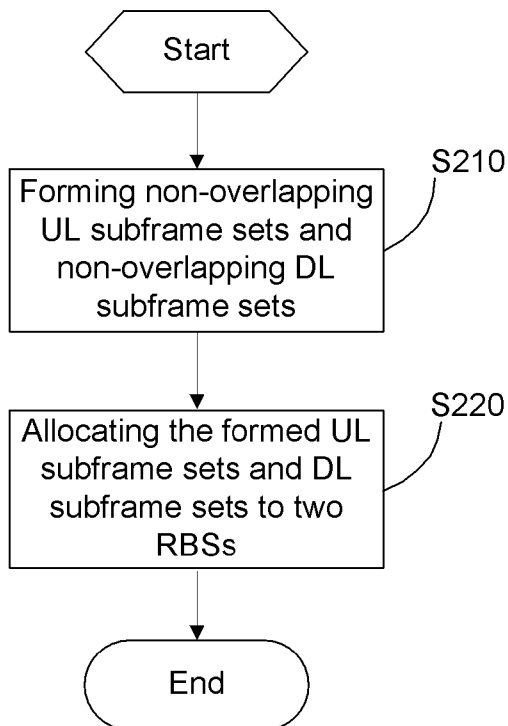

Fig. 2

(57) Abstract: The present disclosure discloses a method of TDM-based resource partition between two radio base stations (RBSs) with which a UE is to perform dual connectivity and an associated radio network node. The method comprises the step of forming (S210) at least two non-overlapping UL subframe sets and at least two non-overlapping DL subframe sets. The method further comprises the step of allocating (S220) at least one of the UL subframe sets and at least one of the DL subframe sets exclusively to each of the RBSs.

WO 2014/117358 A1

TM, TN, TR, TT, TZ, UA, UG, US, UZ, VC, VN, ZA, ZM, ZW.

(84) Designated States (*unless otherwise indicated, for every kind of regional protection available*): ARIPO (BW, GH, GM, KE, LR, LS, MW, MZ, NA, RW, SD, SL, SZ, TZ, UG, ZM, ZW), Eurasian (AM, AZ, BY, KG, KZ, RU, TJ, TM), European (AL, AT, BE, BG, CH, CY, CZ, DE, DK,

EE, ES, FI, FR, GB, GR, HR, HU, IE, IS, IT, LT, LU, LV, MC, MK, MT, NL, NO, PL, PT, RO, RS, SE, SI, SK, SM, TR), OAPI (BF, BJ, CF, CG, CI, CM, GA, GN, GQ, GW, ML, MR, NE, SN, TD, TG).

Published:

— *with international search report (Art. 21(3))*

TDM-BASED RESOURCE PARTITION BETWEEN TWO RADIO BASE STATIONS

TECHNICAL FIELD

- 5 The present disclosure generally relates to the technical field of radio communication systems, and particularly, to Time Division Multiplexing (TDM)-based resource partition between two radio base stations (RBSs).

BACKGROUND

- 10 This section is intended to provide a background to the various embodiments of the technology described in this disclosure. The description in this section may include concepts that could be pursued, but are not necessarily ones that have been previously conceived or pursued. Therefore, unless otherwise indicated herein, what is described in this section is not prior art to the description and/or
15 claims of this disclosure and is not admitted to be prior art by the mere inclusion in this section.

Within the umbrella work of small cell enhancements undertaken by the Third Generation Partnership Project (3GPP), a new transmission scheme known as dual connectivity is being standardized. The dual connectivity is defined from the
20 User equipment (UE)'s perspective, with its name suggesting that the UE communicates with two different RBSs via simultaneous communication connections. The RBSs involved in the dual connectivity may operate on the same frequency or separate frequencies. Each of the RBSs may or may not define a stand-alone cell.

- 25 By way of example, Fig. 1 schematically illustrates a common scenario of the dual connectivity, wherein a UE performs two-way communications with two RBSs (e.g., a macro RBS and a pico RBS).

Although many similarities are shared by dual connectivity, carrier aggregation

and Coordinated Multi-Point (CoMP), the dual connectivity is less demanding on backhaul delay and synchronization between different network points as compared with the carrier aggregation and the CoMP.

A straightforward implementation for dual connectivity would be having a high-profile UE capable of simultaneously transmitting to and receiving from different RBSs perform dual connectivity with two RBSs. Although less system design effort needs to be made for this implementation, the complexity and thus the cost of the high-profile UE are relatively high. In the scenario where the dual connected RBSs operate on separate frequencies, the complexity of the UE would be further increased because the UE needs to support Uplink (UL) dual frequency carriers. In the scenario where the dual connected RBSs operate on the same frequency, there would be some “dead zones” (e.g., in the vicinity of the pico RBS), where the UE cannot hear from the RBSs simultaneously due to a large difference in dynamic range between two Downlink (DL) signals. Another disadvantage of this implementation is that inter-modulation products may result from superposition of more than one UL signals at each RBS.

For UEs incapable of simultaneously transmitting to and receiving from different RBSs to achieve dual connectivity, a different implementation based on TDM-based resource partition between dual connected RBSs may be applied. Although this implementation becomes more complicated in system design, it allows UEs incapable of simultaneously transmitting to and receiving from different RBSs to achieve dual connectivity and thus significantly reduces the requirements on UE complexity. Moreover, when this implementation is applied, the UE does not need to monitor scheduling grants from the dual connected RBSs and the problem with inter-modulation products does not exist.

SUMMARY

An object of the present disclosure is to provide a novel solution for TDM-based resource partition between two RBSs with which a UE is to perform dual

connectivity.

A further object of the present disclosure is to provide a corresponding dual connectivity enabled UE and a method performed by the UE to achieve dual connectivity with the RBSs.

5 According to a first aspect of the disclosure, there is provided a method of TDM-based resource partition between two RBSs with which a UE is to perform dual connectivity. The method comprises the step of forming at least two non-overlapping UL subframe sets and at least two non-overlapping DL subframe sets. The method further comprises the step of allocating at least one of the UL
10 subframe sets and at least one of the DL subframe sets exclusively to each of the RBSs.

The method may be carried out individually by one of the RBSs or a network node coupled to all the RBSs, or jointly by the RBSs.

15 According to a second aspect of the disclosure, there is provided a radio network node adapted to perform TDM-based resource partition between two RBSs with which a UE is to perform dual connectivity. The radio network node comprises a subframe set forming unit and a subframe set allocating unit. The subframe set forming unit is configured to form at least two non-overlapping UL subframe sets and at least two non-overlapping DL subframe sets. The subframe set allocating
20 unit is configured to allocate at least one of the UL subframe sets and at least one of the DL subframe sets exclusively to each of the RBSs.

The radio network node may be one of the RBSs, or a network node coupled to all the RBSs.

25 By forming and allocating non-overlapping UL and DL subframe sets according to the first and second aspects of the present disclosure, collisions between transmissions to dual connected RBSs and collisions between receptions from dual connected RBSs can be avoided, making it possible for UEs incapable of simultaneously transmitting to and receiving from different RBSs to achieve dual

connectivity.

Moreover, with non-overlapping UL and DL subframe sets preformed, the allocation of UL and DL subframes to dual connected RBSs can be simply and flexibly performed in the unit of subframe set. As long as one UL subframe set and one DL subframe set are allocated exclusively to one RBS, collisions
5 between transmissions to/receptions from dual connected RBSs can be avoided.

According to a third aspect of the disclosure, there is provided a dual connectivity enabled UE. The UE comprises a receiver, a transmitter, a memory and a processor. The processor is configured to control the receiver to receive UL
10 subframe sets and DL subframe sets allocated to RBSs with which the UE is to perform dual connectivity, wherein the UL subframe sets respectively allocated to the RBSs are non-overlapping and the DL subframe sets respectively allocated to the RBSs are non-overlapping. The memory is configured to store the received UL subframe sets and DL subframe sets. The processor is further configured to
15 control the transmitter to perform transmissions to the RBSs in the stored UL subframe sets allocated to the respective RBSs and to control the receiver to perform receptions from the RBSs in the stored DL subframe sets allocated to the respective RBSs.

According to a fourth aspect of the disclosure, there is provided a method for use
20 in a dual connectivity enabled UE. The method comprises the step of receiving UL subframe sets and DL subframe sets allocated to RBSs with which the UE is to perform dual connectivity, wherein the UL subframe sets respectively allocated to the RBSs are non-overlapping and the DL subframe sets respectively allocated to the RBSs are non-overlapping. The method further comprises a step of
25 performing dual connectivity with the RBSs by performing transmissions to the RBSs in the UL subframe sets allocated to the respective RBSs and performing receptions from the RBSs in the DL subframe sets allocated to the respective RBSs.

In this manner, a dual connectivity enabled UE may be informed of the UL

subframe sets and DL subframe sets obtained by performing the TDM-based resource partition according to the present disclosure, and achieve dual connectivity.

5 BRIEF DESCRIPTION OF THE DRAWINGS

The above and other objects, features, and advantages of the present disclosure will become apparent from the following descriptions on embodiments of the present disclosure with reference to the drawings, in which:

Fig. 1 is a diagram schematically illustrating an example scenario of dual
10 connectivity wherein the present disclosure can be applied;

Fig. 2 is a flowchart schematically illustrating an example method of TDM-based resource partition between two RBSs according to the present disclosure;

Fig. 3 is a diagram schematically illustrating an example of Hybrid Automatic Repeat Request (HARQ) timing for DL transmission in Frequency Division Duplex
15 (FDD) configuration;

Fig. 4 is a diagram schematically illustrating an example of HARQ timing for UL transmission in FDD configuration;

Fig. 5 is a diagram schematically illustrating an example of HARQ timing for DL transmission in Time Division Duplex (TDD) configuration 0;

20 Fig. 6 is a diagram schematically illustrating an example of HARQ timing for UL transmission in TDD configuration 0;

Fig. 7 is a diagram schematically illustrating an example of HARQ timing for DL transmission in TDD configuration 1;

25 Fig. 8 is a diagram schematically illustrating an example of HARQ timing for UL transmission in TDD configuration 1;

Fig. 9 is a block diagram schematically illustrating a structure of a radio network

node according to the present disclosure;

Fig. 10 is a flowchart schematically illustrating an example method for use in a dual connectivity enabled UE according to the present disclosure; and

Fig. 11 is a block diagram schematically illustrating a structure of a dual connectivity enabled UE according to the present disclosure.

DETAILED DESCRIPTION OF EMBODIMENTS

Hereinafter, the present disclosure is described with reference to embodiments shown in the attached drawings. However, it is to be understood that those descriptions are just provided for illustrative purpose, rather than limiting the present disclosure. Further, in the following, descriptions of known structures and techniques are omitted so as not to unnecessarily obscure the concept of the present disclosure.

Note that although terminology from 3GPP Long Term Evolution (LTE) has been used in this disclosure to exemplify the disclosure, this should not be seen as limiting the scope of the disclosure to only the aforementioned system. Other wireless systems, including Wideband Code Division Multiple Access (WCDMA), Worldwide Interoperability for Microwave Access (WiMax), Ultra Mobile Broadband (UMB) and Global System for Mobile Communications (GSM) may also benefit from exploiting the ideas covered within this disclosure.

Fig. 2 schematically illustrates an example method of TDM-based resource partition between two RBSs with which a UE is to perform dual connectivity according to the present disclosure.

As illustrated in Fig. 2, after a start of the method, non-overlapping UL subframe sets and non-overlapping DL subframe sets are formed (S210). In this step, at least two non-overlapping UL subframe sets and at least two non-overlapping DL subframe sets shall be formed, so that either RBS can be allocated with at least one UL subframe set and at least one DL subframe set. After step S210, at least

one of the UL subframe sets and at least one of the DL subframe sets are allocated exclusively to each of the RBSs (S220). In this manner, collisions between transmissions to dual connected RBSs and collisions between receptions from dual connected RBSs can be avoided, making it possible for a UE incapable of simultaneously transmitting to and receiving from different RBSs to achieve dual connectivity. After step S220, the method is terminated.

The above method may be performed individually by one of the RBS involved in the dual connectivity or a network node coupled to all the RBS. The method may also be performed jointly by the RBSs, and in that case the allocation of the UL subframe sets and the DL subframe sets is coordinated between the RBSs through exchange of the allocated UL subframe sets and DL subframe sets (e.g., via X2 signaling).

The allocated UL subframe sets and DL subframe sets may be signaled to the UE via high-layer signaling in a bitmap manner. If the method is performed individually by one of the RBS involved in the dual connectivity or a network node coupled to all the RBS, the allocated UL subframe sets and DL subframe sets may be signaled to the UE by the RBS or radio network node performing the method. If the method is performed jointly by the RBSs, the allocated UL subframe sets and DL subframe sets may be signaled to the UE by either or both of the radio network nodes.

The allocation of UL and DL subframe sets may be based on traffic characteristics of communication links between the UE and the RBSs and/or the number of dual connectivity enabled UEs to be served by the RBSs. For example, if there is a higher data rate requirement on the DL and/or UL between the UE and one of the RBS, more DL and/or UL subframe sets can be allocated to the RBS as compared with the other RBS. If there are two UEs to be served by the RBSs, a part of the UL and DL subframe sets may be allocated for use by one of the UEs and the remaining part of the UL and DL subframe sets may be reserved to be allocated for use by the other UE.

Performing the above-described method of TDM-based resource partition under certain constraints may bring additional benefits.

For example, the TDM-based resource partition may be performed on a HARQ process level. That is to say, each UL subframe set and a corresponding DL subframe set may be formed from UL and DL subframes belonging to the same HARQ process and bundled together. In this manner, the same HARQ process can be allocated to a single RBS and completed faster. As compared with sharing the same HARQ process by different RBSs, this scheme significantly reduces the processing complexity and delay of HARQ processes.

10 Additionally, the UL grants, DL assignments and PDSCH of a RBS may be transmitted in the same DL subframe. The RBS can then transmit DL assignments, UL grants, HARQ-Acknowledgement (HARQ-ACK) feedback corresponding to UL data transmissions and DL data in the same DL subframe set, and receive HARQ-ACK feedback corresponding to DL data transmissions
15 and UL data in the same UL subframe set. In this manner, many a DL/UL subframe may carry at least two kinds of information and resource utilization can be significantly increased.

The above-described method of TDM-based resource partition according to the present disclosure may be applied to both TDD and FDD schemes.

20 In the following, 8 examples of non-overlapping UL and DL subframe sets obtained by applying the TDM-based resource partition method under all constraints will be given. Those skilled in the art would appreciate that these examples are given for illustration purpose only and different non-overlapping UL and DL subframe sets may be obtained by applying the TDM-based resource
25 partition method under fewer constraints.

The first example relates to FDD configuration. The HARQ timing for DL and UL transmissions in the FDD configuration has been given in [1].

Specifically, for the DL transmission, if subframe n is allocated to one RBS for

Physical Downlink Shared CHannel (PDSCH) transmission, this RBS is expected to receive HARQ-ACK feedback in respect to the PDSCH transmission in subframe $n+4$ from the UE. By way of example, Fig. 3 illustrates the HARQ timing for DL transmission in FDD configuration when subframe 0 is allocated for PDSCH transmission.

For the UL transmission, if subframe n is allocated to one RBS for PUSCH transmission, this RBS is expected to send an UL grant in subframe $n-4$, to send HARQ-ACK feedback in respect to the Physical Uplink Shared CHannel (PUSCH) transmission in subframe $n+4$, and to retransmit PUSCH in subframe $n+8$. By way of example, Fig. 4 illustrates the HARQ timing for UL transmission in FDD configuration when subframe 4 is allocated for PUSCH transmission.

According to the HARQ timing for UL transmission, DL subframe sets each corresponding to an UL HARQ process and UL subframe sets each corresponding to the same UL HARQ process can be formed and bundled together. Both of the DL subframe set and the UL subframe set have a periodicity of 8ms, and an UL subframe set has a delay of 4ms relative to its corresponding DL subframe set.

All possible bundled subframe sets for FDD configuration are listed below, with D denoting a subframe number of a DL subframe and U denoting a subframe number of an UL subframe.

Set 1: $D \{0, 8, 16, \dots\}$ and $U \{4, 12, 20, \dots\}$;

Set 2: $D \{1, 9, 17, \dots\}$ and $U \{5, 13, 21, \dots\}$;

Set 3: $D \{2, 10, 18, \dots\}$ and $U \{6, 14, 22, \dots\}$;

Set 4: $D \{3, 11, 19, \dots\}$ and $U \{7, 15, 23, \dots\}$;

Set 5: $D \{4, 12, 20, \dots\}$ and $U \{8, 12, 20, \dots\}$;

Set 6: $D \{5, 13, 21, \dots\}$ and $U \{9, 13, 21, \dots\}$;

Set 7: $D \{6, 14, 22, \dots\}$ and $U \{10, 14, 22, \dots\}$; and

Set 8: $D \{7, 15, 23, \dots\}$ and $U \{11, 15, 23, \dots\}$.

Mathematically, the above subframe sets can be formulated as follows:

- Set 1: $\{D|D=8*k, k=0, 1, 2, \dots\}$ and $\{U|U=8*k+4, k=0, 1, 2, \dots\}$;
 Set 2: $\{D|D=8*k+1, k=0, 1, 2, \dots\}$ and $\{U|U=8*k+5, k=0, 1, 2, \dots\}$;
 Set 3: $\{D|D=8*k+2, k=0, 1, 2, \dots\}$ and $\{U|U=8*k+6, k=0, 1, 2, \dots\}$;
 5 Set 4: $\{D|D=8*k+3, k=0, 1, 2, \dots\}$ and $\{U|U=8*k+7, k=0, 1, 2, \dots\}$;
 Set 5: $\{D|D=8*k+4, k=0, 1, 2, \dots\}$ and $\{U|U=8*k, k=0, 1, 2, \dots\}$;
 Set 6: $\{D|D=8*k+5, k=0, 1, 2, \dots\}$ and $\{U|U=8*k+1, k=0, 1, 2, \dots\}$;
 Set 7: $\{D|D=8*k+6, k=0, 1, 2, \dots\}$ and $\{U|U=8*k+2, k=0, 1, 2, \dots\}$; and
 Set 8: $\{D|D=8*k+7, k=0, 1, 2, \dots\}$ and $\{U|U=8*k+3, k=0, 1, 2, \dots\}$.

- 10 One set can be allocated exclusively to either dual connected RBS, and each RBS can be allocated with one or more sets. For the sake of illustration, subframes belonging to set 1 are hatched in Figs. 3 and 4.

The second to eighth examples relate to TDD configurations 0-6, respectively.

- 15 The HARQ timing for DL and UL transmissions in the TDD configurations 0-6 has been given in [1].

Specifically, for the DL transmission, if subframe n is allocated to one RBS for PDSCH transmission, this RBS is expected to receive HARQ-ACK feedback in respect to the PDSCH transmission in subframe $n+k$ from the UE. The definition of k is given in Table 10.1.3.1-1 in [1].

- 20 For the UL transmission, if subframe n is allocated to one RBS for PUSCH transmission, this RBS is expected to send an UL grant in subframe $n-k$, to receive HARQ-ACK feedback in respect to the PUSCH transmission in subframe $n+k'$, and to retransmit PUSCH in subframe $n+k''$. The definitions of k , k' and k'' are also given in [1].

- 25 By way of example, Figs. 5 and 7 respectively illustrate the HARQ timing for UL transmission in TDD configurations 0 and 1 when subframe 0 is allocated for PDSCH transmission, Fig. 6 illustrates the HARQ timing for DL transmission in TDD configuration 0 when subframe 4 is allocated for PUSCH transmission, and

Fig. 8 illustrates the HARQ timing for DL transmission in TDD configuration 0 when subframe 7 is allocated for PUSCH transmission.

According to the HARQ timing for UL transmission in TDD configuration 0, all bundled subframe sets corresponding to UL HARQ processes may be listed below, with D denoting a subframe number of a DL subframe and U denoting a subframe number of an UL subframe.

Set 1: D {0, 10, 21, 35, 45, 56,...} and
U {4, 17, 28, 39, 52, 63,...};

Set 2: D {0, 11, 25, 35, 46, 60,...} and
U {7, 18, 29, 42, 53, 64,...};

Set 3: D {1, 15, 25, 36, 50, 60,...} and
U {8, 19, 32, 43, 54, 67,...};

Set 4: D {5, 15, 26, 40, 50, 61,...} and
U {9, 22, 33, 44, 57, 68,...};

Set 5: D {5, 16, 30, 40, 51, 65,...} and
U {12, 23, 34, 47, 58, 69,...};

Set 6: D {6, 20, 30, 41, 55, 65,...} and
U {13, 24, 37, 48, 59, 72,...}; and

Set 7: D {10, 20, 31, 45, 55, 66,...} and
U {14, 27, 38, 49, 62, 73,...}.

Mathematically, these subframe sets can be formulated as follows:

Set 1: $\{D|D=X(\text{mod}(k,3))+35*\text{floor}(k/3), k=0, 1, 2, \dots\}$ and
 $\{U|U=Y(\text{mod}(k,3))+35*\text{floor}(k/3), k=0, 1, 2, \dots\}$,
where $X(0)=0, X(1)=10, X(2)=21; Y(0)=4, Y(1)=17, Y(3)=28;$

Set 2: $\{D|D=X(\text{mod}(k,3))+35*\text{floor}(k/3), k=0, 1, 2, \dots\}$ and
 $\{U|U=Y(\text{mod}(k,3))+35*\text{floor}(k/3), k=0, 1, 2, \dots\}$,
where $X(0)=0, X(1)=11, X(2)=25; Y(0)=7, Y(1)=18, Y(3)=29;$

Set 3: $\{D|D=X(\text{mod}(k,3))+35*\text{floor}(k/3), k=0, 1, 2, \dots\}$ and
 $\{U|U=Y(\text{mod}(k,3))+35*\text{floor}(k/3), k=0, 1, 2, \dots\}$,

where $X(0)=1$, $X(1)=15$, $X(2)=25$; $Y(0)=8$, $Y(1)=19$, $Y(3)=32$;

Set 4: $\{D|D=X(\text{mod}(k,3))+35*\text{floor}(k/3), k=0, 1, 2, \dots\}$ and
 $\{U|U=Y(\text{mod}(k,3))+35*\text{floor}(k/3), k=0, 1, 2, \dots\}$,

where $X(0)=5$, $X(1)=15$, $X(2)=26$; $Y(0)=9$, $Y(1)=22$, $Y(3)=33$;

5 Set 5: $\{D|D=X(\text{mod}(k,3))+35*\text{floor}(k/3), k=0, 1, 2, \dots\}$ and
 $\{U|U=Y(\text{mod}(k,3))+35*\text{floor}(k/3), k=0, 1, 2, \dots\}$,

where $X(0)=5$, $X(1)=16$, $X(2)=30$; $Y(0)=12$, $Y(1)=23$, $Y(3)=34$;

Set 6: $\{D|D=X(\text{mod}(k,3))+35*\text{floor}(k/3), k=0, 1, 2, \dots\}$ and
 $\{U|U=Y(\text{mod}(k,3))+35*\text{floor}(k/3), k=0, 1, 2, \dots\}$,

10 where $X(0)=6$, $X(1)=20$, $X(2)=30$; $Y(0)=13$, $Y(1)=24$, $Y(3)=37$; and

Set 7: $\{D|D=X(\text{mod}(k,3))+35*\text{floor}(k/3), k=0, 1, 2, \dots\}$ and
 $\{U|U=Y(\text{mod}(k,3))+35*\text{floor}(k/3), k=0, 1, 2, \dots\}$,

where $X(0)=10$, $X(1)=20$, $X(2)=31$; $Y(0)=14$, $Y(1)=27$, $Y(3)=38$.

However, it should be noted that, in TDD configuration 0, the HARQ-ACK

15 feedback corresponding to multiple UL transmissions may fall in the same DL subframe. Accordingly, different UL HARQ processes may have HARQ-ACK feedback (i.e., Physical Hybrid ARQ Indicator CHannel (PHICH)) in the same DL subframe. For example, both HARQ process 1 and HARQ process 2 have PHICH in subframe 0 and 35.

20 In this case, it is necessary to select, from the available 7 subframe sets, non-overlapping subframe sets to be allocated to the RBSs. By way of example, possible selection of the subframe sets can be {set 1, set 3, set 5}, {set 1, set 3, set 6}, {set 1, set 3, set 7}, {set 1, set 4, set 6}, {set 1, set 4, set 7}, {set 1, set 5, set 7}, {set 2, set 4, set 6}, {set 2, set 4, set 7}, {set 2, set 5, set 7} or {set 3, set 5,
 25 set 7}. Further, if set 1, set 3, set 5 are selected, set 1 and set 2 may be allocated to one of the RBS while set 3 may be allocated to the other RBS. For the sake of illustration, subframes belonging to set 1 are hatched in Figs. 5 and 6.

The partitioning result based on the HARQ timing for UL transmission can be

directly applied for DL transmission, i.e. the non-overlapping DL subframe sets can also be used for DL assignments and PDSCH transmissions.

According to the HARQ timing for UL transmission in TDD configuration 1, all bundled subframe sets corresponding to UL HARQ processes may be listed below, with D denoting a subframe number of a DL subframe and U denoting a subframe number of an UL subframe.

Set 1: D {1, 11, 21, 31, 41, 51,...} and U {7, 17, 27, 37, 47, 57,...};

Set 2: D {4, 14, 24, 34, 44, 54,...} and U {8, 18, 28, 38, 48, 58,...};

Set 3: D {6, 16, 26, 36, 46, 56,...} and U {12, 22, 32, 42, 52, 62,...}; and

Set 4: D {9, 19, 29, 39, 49, 59,...} and U {13, 23, 33, 43, 53, 63,...}.

As can be seen, all bundled subframe sets corresponding to UL HARQ processes are non-overlapping.

However, it is to be noted that, in TDD configuration 1, the HARQ-ACK feedback corresponding to DL transmissions in multiple DL subframes may fall in the same UL subframe. For example, DL transmissions in DL subframe 0 and DL subframe 1 have HARQ-ACK feedback in UL subframe 7. Similarly, DL transmissions in DL subframe 5 and DL subframe 6 have HARQ-ACK feedback in UL subframe 12. For such DL subframes to be allocated to the same RBS, it is preferable to include them in the same DL subframe set. To this end, the bundled subframe sets may be amended as follows.

Set 1: D {0, 1, 10, 11, 20, 21, 30, 31, 40, 41, 50, 51,...} and
U {7, 17, 27, 37, 47, 57,...};

Set 2: D {4, 14, 24, 34, 44, 54,...} and
U {8, 18, 28, 38, 48, 58,...};

Set 3: D {5, 6, 15, 16, 25, 26, 35, 36, 45, 46, 55, 56,...} and
U {2, 12, 22, 32, 42, 52, 62,...}; and

Set 4: D {9, 19, 29, 39, 49, 59,...} and
U {3, 13, 23, 33, 43, 53, 63,...}.

Mathematically, these subframe sets can be formulated as follows:

- Set 1: $\{D|D=X(\text{mod}(k,2))+10*\text{floor}(k/2), k=0, 1, 2, \dots\}$ and
 $\{U|U=10*k+7, k=0, 1, 2, \dots\}$,
 where $X(0)=0, X(1)=1$;
- 5 Set 2: $\{D|D=10*k+4, k=0, 1, 2, \dots\}$ and
 $\{U|U=10*k+8, k=0, 1, 2, \dots\}$;
- Set 3: $\{D|D=X(\text{mod}(k,2))+10*\text{floor}(k/2), k=0, 1, 2, \dots\}$ and
 $\{U|U=10*k+2, k=0, 1, 2, \dots\}$,
 where $X(0)=5, X(1)=6$; and
- 10 Set 4: $\{D|D=10*k+9, k=0, 1, 2, \dots\}$ and
 $\{U|U=10*k+3, k=0, 1, 2, \dots\}$.

Similarly, for TDD configuration 2, all bundled subframe sets can be formulated as follows:

- Set 1: $\{D|D=X(\text{mod}(k,4))+10*\text{floor}(k/4), k=0, 1, 2, \dots\}$ and
 15 $\{U|U=10*k+7, k=0, 1, 2, \dots\}$,
 where $X(0)=0, X(1)=1, X(2)=3, X(3)=9$; and
- Set 2: $\{D|D=X(\text{mod}(k,4))+10*\text{floor}(k/4), k=0, 1, 2, \dots\}$ and
 $\{U|U=10*k+4, k=0, 1, 2, \dots\}$,
 where $X(0)=4, X(1)=5, X(2)=6, X(3)=8$.

20 For TDD configuration 3, all bundled subframe sets can be formulated as follows:

- Set 1: $\{D|D=10*k, k=0, 1, 2, \dots\}$ and
 $\{U|U=10*k+4, k=0, 1, 2, \dots\}$; and
- Set 2: $\{D|D=X(\text{mod}(k,5))+10*\text{floor}(k/5), k=0, 1, 2, \dots\}$ and
 $\{U|U=Y(\text{mod}(k/2))+10*\text{floor}(k/2), k=0, 1, 2, \dots\}$,
 25 where $X(0)=1, X(1)=5, X(2)=6, X(3)=7, X(4)=8; Y(0)=2, Y(1)=3$.

For TDD configuration 4, all bundled subframe sets can be formulated as follows:

- Set 1: $\{D|D=10*k+8, k=0, 1, 2, \dots\}$ and
 $\{U|U=10*k+2, k=0, 1, 2, \dots\}$; and

Set 2: $\{D|D=10*k+9, k=0, 1, 2, \dots\}$ and
 $\{U|U=10*k+3, k=0, 1, 2, \dots\}$.

For TDD configuration 6, all bundled subframe sets can be formulated as follows:

5 Set 1: $\{D|D=X(\text{mod}(k,2))+25*\text{floor}(k/2), k=0, 1, 2, \dots\}$ and
 $\{U|U=Y(\text{mod}(k/2))+25*\text{floor}(k/2), k=0, 1, 2, \dots\}$,
 where $X(0)=0, X(1)=11; Y(0)=7, Y(1)=18;$

Set 2: $\{D|D=X(\text{mod}(k,2))+25*\text{floor}(k/2), k=0, 1, 2, \dots\}$ and
 $\{U|U=Y(\text{mod}(k/2))+25*\text{floor}(k/2), k=0, 1, 2, \dots\}$,
 where $X(0)=1, X(1)=15; Y(0)=8, Y(1)=22;$

10 Set 3: $\{D|D=X(\text{mod}(k,2))+25*\text{floor}(k/2), k=0, 1, 2, \dots\}$ and
 $\{U|U=Y(\text{mod}(k/2))+25*\text{floor}(k/2), k=0, 1, 2, \dots\}$,
 where $X(0)=5, X(1)=16; Y(0)=12, Y(1)=23;$

Set 4: $\{D|D=X(\text{mod}(k,2))+25*\text{floor}(k/2), k=0, 1, 2, \dots\}$ and
 $\{U|U=Y(\text{mod}(k/2))+25*\text{floor}(k/2), k=0, 1, 2, \dots\}$,
 15 where $X(0)=6, X(1)=19; Y(0)=13, Y(1)=24;$

Set 5: $\{D|D=X(\text{mod}(k,2))+25*\text{floor}(k/2), k=0, 1, 2, \dots\}$ and
 $\{U|U=Y(\text{mod}(k/2))+25*\text{floor}(k/2), k=0, 1, 2, \dots\}$,
 where $X(0)=9, X(1)=20; Y(0)=14, Y(1)=27;$ and

Set 6: $\{D|D=X(\text{mod}(k,2))+25*\text{floor}(k/2), k=0, 1, 2, \dots\}$ and
 20 $\{U|U=Y(\text{mod}(k/2))+25*\text{floor}(k/2), k=0, 1, 2, \dots\}$,
 where $X(0)=10, X(1)=21; Y(0)=17, Y(1)=28.$

For TDD configuration 5, there is only one UL process. It is not possible to apply the TDM-based resource partition method under all constraints. However, those skilled in the art would appreciate that non-overlapping UL and DL subframe sets
 25 may still be obtained by applying the TDM-based resource partition method under fewer constraints.

In the following, a structure of a radio network node 900 according to the present disclosure will be given with reference to Fig. 9. The radio network node 900 may

be one of the RBSs to which a UE is to perform dual connectivity, or a network node coupled to all the RBSs.

As shown in Fig. 9, the radio network node 900 comprises a subframe set forming unit 910 and a subframe set allocating unit 920. The subframe set forming unit 910 is configured to form at least two non-overlapping UL subframe sets and at least two non-overlapping DL subframe sets. The subframe set allocating unit 920 is configured to allocate at least one of the UL subframe sets and at least one of the DL subframe sets exclusively to each of the RBSs.

In an embodiment, the subframe set forming unit 910 and the subframe set allocating unit 920 may be implemented by the same physical unit.

As a method performed by a UE to achieve dual connectivity with two RBSs, Fig. 10 illustrates that the UE receives UL subframe sets and DL subframe sets (S1010), and then performs dual connectivity with the RBSs (S1020). The UL subframe sets and DL subframe sets received at step S1010 are obtained by performing the TDM-based resource partition according to the present disclosure. Accordingly, the UL subframe sets respectively allocated to the RBSs are non-overlapping and the DL subframe sets respectively allocated to the RBSs are non-overlapping. At step S1020, the UE transmits to the RBSs in the UL subframe sets allocated to the respective RBSs and receives from the RBSs in the DL subframe sets allocated to the respective RBSs.

Fig. 11 is a schematic block diagram of a dual connectivity enabled UE 1100 according to the present disclosure. As shown, the dual connectivity enabled UE 1100 comprises a receiver 1110, a transmitter 1120, a memory 1130 and a processor 1140. The processor 1140 controls, e.g., according to instructions stored in the memory 1130, the receiver 1110 to receive UL subframe sets and DL subframe sets allocated to RBSs with which the UE is to perform dual connectivity, wherein the UL subframe sets respectively allocated to the RBSs are non-overlapping and the DL subframe sets respectively allocated to the RBSs are non-overlapping. The memory 1130 stores the received UL subframe sets

and DL subframe sets. The processor 1140 further controls the transmitter 1120 to perform transmissions to the RBSs in the stored UL subframe sets allocated to the respective RBSs and controls the receiver 1110 to perform receptions from the RBSs in the stored DL subframe sets allocated to the respective RBSs.

- 5 It is to be noted that the term "processor" used herein shall also be construed to refer to other hardware capable of performing the same functions and/or executing software, and may include, without limitation, digital signal processor (DSP) hardware, reduced instruction set processor, hardware (e.g., digital or analog) circuitry, and (where appropriate) state machines capable of performing
10 such functions.

The present disclosure is described above with reference to the embodiments thereof. However, those embodiments are provided just for illustrative purpose, rather than limiting the present disclosure. The scope of the disclosure is defined by the attached claims as well as equivalents thereof. Those skilled in
15 the art can make various alternations and modifications without departing from the scope of the disclosure, which all fall into the scope of the disclosure.

REFERENCES

- [1] 3GPP TS 36.213 v11.0.0, "Evolved Universal Terrestrial Radio Access
20 (E-UTRA); Physical layer procedures".

WHAT IS CLAIMED IS:

1. A method of Time Division Multiplexing (TDM)-based resource partition between two Radio Base Stations (RBSs) with which a User Equipment (UE) is to
5 perform dual connectivity, the method comprising:

forming (S210) at least two non-overlapping Uplink (UL) subframe sets and at least two non-overlapping Downlink (DL) subframe sets; and

allocating (S220) at least one of the UL subframe sets and at least one of the DL subframe sets exclusively to each of the RBSs.

10

2. The method according to claim 1, wherein the allocated UL subframe sets and DL subframe sets are signaled to the UE via high-layer signaling in a bitmap manner.

15 3. The method according to claim 1 or 2, wherein the method is carried out individually by one of the RBSs or a network node coupled to both of the RBSs, or jointly by the RBSs.

20 4. The method according to claim 3, wherein the allocation of the UL subframe sets and the DL subframe sets is coordinated between the RBSs through exchange of the allocated UL subframe sets and DL subframe sets, if the method is carried out jointly by the RBSs.

25 5. The method according to claim 1 or 2, wherein the allocation of UL and DL subframe sets is based on traffic characteristics of communication links between the UE and the RBSs and/or on the number of dual connectivity enabled UEs to be served by the RBSs.

6. The method according to claim 1 or 2, wherein each UL subframe set is

bundled with a DL subframe set to form a bundled subframe set to be allocated to a single one of the RBS, wherein the UL subframe set includes UL subframes used for a Hybrid Automatic Repeat Request (HARQ) process and the DL subframe set includes DL subframes used for the HARQ process.

5

7. The method according to claim 6, wherein the single RBS transmits DL assignments, UL grants, HARQ-Acknowledgement (HARQ-ACK) feedback corresponding to UL data transmissions and DL data in the same DL subframe set and receives HARQ-ACK feedback corresponding to DL data transmissions and UL data in the same UL subframe set.

10

8. The method according to claim 7, wherein an UL subframe in the UL subframe set carries HARQ-ACK feedback for DL data carried by multiple DL subframes in the DL subframe set.

15

9. The method according to claim 6 or 7, wherein for Frequency Division Duplex (FDD) configuration, the bundled subframe set is one of the following:

Set 1: $\{D|D=8*k, k=0, 1, 2, \dots\}$ and $\{U|U=8*k+4, k=0, 1, 2, \dots\}$;

Set 2: $\{D|D=8*k+1, k=0, 1, 2, \dots\}$ and $\{U|U=8*k+5, k=0, 1, 2, \dots\}$;

20 Set 3: $\{D|D=8*k+2, k=0, 1, 2, \dots\}$ and $\{U|U=8*k+6, k=0, 1, 2, \dots\}$;

Set 4: $\{D|D=8*k+3, k=0, 1, 2, \dots\}$ and $\{U|U=8*k+7, k=0, 1, 2, \dots\}$;

Set 5: $\{D|D=8*k+4, k=0, 1, 2, \dots\}$ and $\{U|U=8*k, k=0, 1, 2, \dots\}$;

Set 6: $\{D|D=8*k+5, k=0, 1, 2, \dots\}$ and $\{U|U=8*k+1, k=0, 1, 2, \dots\}$;

Set 7: $\{D|D=8*k+6, k=0, 1, 2, \dots\}$ and $\{U|U=8*k+2, k=0, 1, 2, \dots\}$; and

25 Set 8: $\{D|D=8*k+7, k=0, 1, 2, \dots\}$ and $\{U|U=8*k+3, k=0, 1, 2, \dots\}$,

wherein D denotes a subframe number of a DL subframe and U denotes a subframe number of an UL subframe.

10. The method according to claim 6 or 7, wherein for Time Division Duplex

(TDD) configuration 0, the bundled subframe set is one of the following:

- Set 1: $\{D|D=X(\text{mod}(k,3))+35*\text{floor}(k/3), k=0, 1, 2, \dots\}$ and
 $\{U|U=Y(\text{mod}(k,3))+35*\text{floor}(k/3), k=0, 1, 2, \dots\}$,
 where $X(0)=0, X(1)=10, X(2)=21; Y(0)=4, Y(1)=17, Y(3)=28;$
- 5 Set 2: $\{D|D=X(\text{mod}(k,3))+35*\text{floor}(k/3), k=0, 1, 2, \dots\}$ and
 $\{U|U=Y(\text{mod}(k,3))+35*\text{floor}(k/3), k=0, 1, 2, \dots\}$,
 where $X(0)=0, X(1)=11, X(2)=25; Y(0)=7, Y(1)=18, Y(3)=29;$
- Set 3: $\{D|D=X(\text{mod}(k,3))+35*\text{floor}(k/3), k=0, 1, 2, \dots\}$ and
 $\{U|U=Y(\text{mod}(k,3))+35*\text{floor}(k/3), k=0, 1, 2, \dots\}$,
 10 where $X(0)=1, X(1)=15, X(2)=25; Y(0)=8, Y(1)=19, Y(3)=32;$
- Set 4: $\{D|D=X(\text{mod}(k,3))+35*\text{floor}(k/3), k=0, 1, 2, \dots\}$ and
 $\{U|U=Y(\text{mod}(k,3))+35*\text{floor}(k/3), k=0, 1, 2, \dots\}$,
 where $X(0)=5, X(1)=15, X(2)=26; Y(0)=9, Y(1)=22, Y(3)=33;$
- Set 5: $\{D|D=X(\text{mod}(k,3))+35*\text{floor}(k/3), k=0, 1, 2, \dots\}$ and
 15 $\{U|U=Y(\text{mod}(k,3))+35*\text{floor}(k/3), k=0, 1, 2, \dots\}$,
 where $X(0)=5, X(1)=16, X(2)=30; Y(0)=12, Y(1)=23, Y(3)=34;$
- Set 6: $\{D|D=X(\text{mod}(k,3))+35*\text{floor}(k/3), k=0, 1, 2, \dots\}$ and
 $\{U|U=Y(\text{mod}(k,3))+35*\text{floor}(k/3), k=0, 1, 2, \dots\}$,
 where $X(0)=6, X(1)=20, X(2)=30; Y(0)=13, Y(1)=24, Y(3)=37;$ and
- 20 Set 7: $\{D|D=X(\text{mod}(k,3))+35*\text{floor}(k/3), k=0, 1, 2, \dots\}$ and
 $\{U|U=Y(\text{mod}(k,3))+35*\text{floor}(k/3), k=0, 1, 2, \dots\}$,
 where $X(0)=10, X(1)=20, X(2)=31; Y(0)=14, Y(1)=27, Y(3)=38,$

wherein D denotes a subframe number of a DL subframe and U denotes a subframe number of an UL subframe.

25

11. The method according to claim 8, wherein for TDD configuration 1, the bundled subframe set is one of the following:

- Set 1: $\{D|D=X(\text{mod}(k,2))+10*\text{floor}(k/2), k=0, 1, 2, \dots\}$ and
 $\{U|U=10*k+7, k=0, 1, 2, \dots\}$, where $X(0)=0, X(1)=1;$

Set 2: $\{D|D=10*k+4, k=0, 1, 2, \dots\}$ and
 $\{U|U=10*k+8, k=0, 1, 2, \dots\}$;

Set 3: $\{D|D=X(\text{mod}(k,2))+10*\text{floor}(k/2), k=0, 1, 2, \dots\}$ and
 $\{U|U=10*k+2, k=0, 1, 2, \dots\}$, where $X(0)=5, X(1)=6$; and

5 Set 4: $\{D|D=10*k+9, k=0, 1, 2, \dots\}$ and
 $\{U|U=10*k+3, k=0, 1, 2, \dots\}$,

wherein D denotes a subframe number of a DL subframe and U denotes a subframe number of an UL subframe.

10 12. The method according to claim 6 or 7, wherein for TDD configuration 2, the bundled subframe set is one of the following:

Set 1: $\{D|D=X(\text{mod}(k,4))+10*\text{floor}(k/4), k=0, 1, 2, \dots\}$ and
 $\{U|U=10*k+7, k=0, 1, 2, \dots\}$,
 where $X(0)=0, X(1)=1, X(2)=3, X(3)=9$; and

15 Set 2: $\{D|D=X(\text{mod}(k,4))+10*\text{floor}(k/4), k=0, 1, 2, \dots\}$ and
 $\{U|U=10*k+4, k=0, 1, 2, \dots\}$,
 where $X(0)=4, X(1)=5, X(2)=6, X(3)=8$,

wherein D denotes a subframe number of a DL subframe and U denotes a subframe number of an UL subframe.

20

13. The method according to claim 6 or 7, wherein for TDD configuration 3, the bundled subframe set is one of the following:

Set 1: $\{D|D=10*k, k=0, 1, 2, \dots\}$ and
 $\{U|U=10*k+4, k=0, 1, 2, \dots\}$; and

25 Set 2: $\{D|D=X(\text{mod}(k,5))+10*\text{floor}(k/5), k=0, 1, 2, \dots\}$ and
 $\{U|U=Y(\text{mod}(k/2))+10*\text{floor}(k/2), k=0, 1, 2, \dots\}$,
 where $X(0)=1, X(1)=5, X(2)=6, X(3)=7, X(4)=8; Y(0)=2, Y(1)=3$,

wherein D denotes a subframe number of a DL subframe and U denotes a subframe number of an UL subframe.

14. The method according to claim 6 or 7, wherein for TDD configuration 4, the bundled subframe set is one of the following:

Set 1: $\{D|D=10*k+8, k=0, 1, 2, \dots\}$ and $\{U|U=10*k+2, k=0, 1, 2, \dots\}$; and

5 Set 2: $\{D|D=10*k+9, k=0, 1, 2, \dots\}$ and $\{U|U=10*k+3, k=0, 1, 2, \dots\}$,

wherein D denotes a subframe number of a DL subframe and U denotes a subframe number of an UL subframe.

15. The method according to claim 6 or 7, wherein for TDD configuration 6, the bundled subframe set is one of the following:

Set 1: $\{D|D=X(\text{mod}(k,2))+25*\text{floor}(k/2), k=0, 1, 2, \dots\}$ and
 $\{U|U=Y(\text{mod}(k/2))+25*\text{floor}(k/2), k=0, 1, 2, \dots\}$,
 where $X(0)=0, X(1)=11; Y(0)=7, Y(1)=18;$

Set 2: $\{D|D=X(\text{mod}(k,2))+25*\text{floor}(k/2), k=0, 1, 2, \dots\}$ and
 15 $\{U|U=Y(\text{mod}(k/2))+25*\text{floor}(k/2), k=0, 1, 2, \dots\}$,
 where $X(0)=1, X(1)=15; Y(0)=8, Y(1)=22;$

Set 3: $\{D|D=X(\text{mod}(k,2))+25*\text{floor}(k/2), k=0, 1, 2, \dots\}$ and
 $\{U|U=Y(\text{mod}(k/2))+25*\text{floor}(k/2), k=0, 1, 2, \dots\}$,
 where $X(0)=5, X(1)=16; Y(0)=12, Y(1)=23;$

Set 4: $\{D|D=X(\text{mod}(k,2))+25*\text{floor}(k/2), k=0, 1, 2, \dots\}$ and
 20 $\{U|U=Y(\text{mod}(k/2))+25*\text{floor}(k/2), k=0, 1, 2, \dots\}$,
 where $X(0)=6, X(1)=19; Y(0)=13, Y(1)=24;$

Set 5: $\{D|D=X(\text{mod}(k,2))+25*\text{floor}(k/2), k=0, 1, 2, \dots\}$ and
 $\{U|U=Y(\text{mod}(k/2))+25*\text{floor}(k/2), k=0, 1, 2, \dots\}$,
 25 where $X(0)=9, X(1)=20; Y(0)=14, Y(1)=27;$ and

Set 6: $\{D|D=X(\text{mod}(k,2))+25*\text{floor}(k/2), k=0, 1, 2, \dots\}$ and
 $\{U|U=Y(\text{mod}(k/2))+25*\text{floor}(k/2), k=0, 1, 2, \dots\}$,
 where $X(0)=10, X(1)=21; Y(0)=17, Y(1)=28,$

wherein D denotes a subframe number of a DL subframe and U denotes a

subframe number of an UL subframe.

16. A radio network node (900) adapted to perform TDM-based resource partition between two RBSs with which a UE is to perform dual connectivity, the
5 radio network node comprising:

a subframe set forming unit (910) configured to form at least two non-overlapping UL subframe sets and at least two non-overlapping DL subframe sets; and

10 a subframe set allocating unit (920) configured to allocate at least one of the UL subframe sets and at least one of the DL subframe sets exclusively to each of the RBSs.

17. The radio network node (900) according to claim 16, wherein the radio network node is one of the RBSs.

15

18. The radio network node (900) according to claim 16, wherein the radio network node is a network node coupled to both of the RBSs.

19. A method for use in a dual connectivity enabled UE, comprising:

20 receiving (S1010) UL subframe sets and DL subframe sets allocated to RBSs with which the UE is to perform dual connectivity, wherein the UL subframe sets respectively allocated to the RBSs are non-overlapping and the DL subframe sets respectively allocated to the RBSs are non-overlapping; and

25 performing (S1020) dual connectivity with the RBSs by performing transmissions to the RBSs in the UL subframe sets allocated to the respective RBSs and performing receptions from the RBSs in the DL subframe sets allocated to the respective RBSs.

20. A dual connectivity enabled UE (1100) comprising a receiver (1110), a

transmitter (1120), a memory (1130) and a processor (1140),

wherein

the processor (1140) is configured to control the receiver (1110) to receive UL subframe sets and DL subframe sets allocated to RBSs with which the UE is to perform dual connectivity, wherein the UL subframe sets respectively allocated to the RBSs are non-overlapping and the DL subframe sets respectively allocated to the RBSs are non-overlapping;

the memory (1130) is configured to store the received UL subframe sets and DL subframe sets; and

the processor (1140) is further configured to control the transmitter (1120) to perform transmissions to the RBSs in the stored UL subframe sets allocated to the respective RBSs and to control the receiver (1110) to perform receptions from the RBSs in the stored DL subframe sets allocated to the respective RBSs.

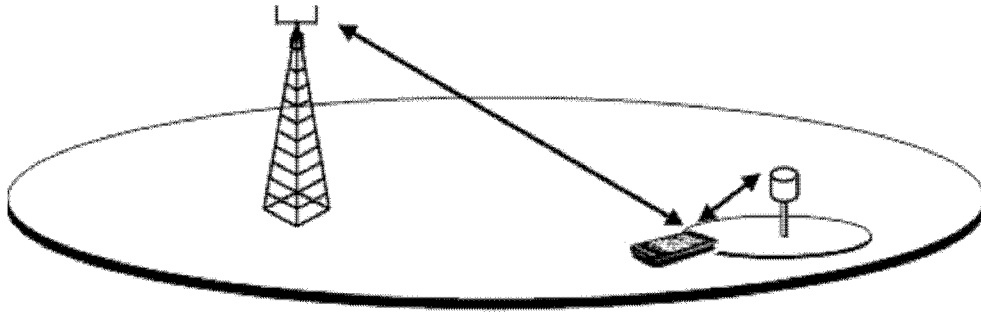

Fig. 1

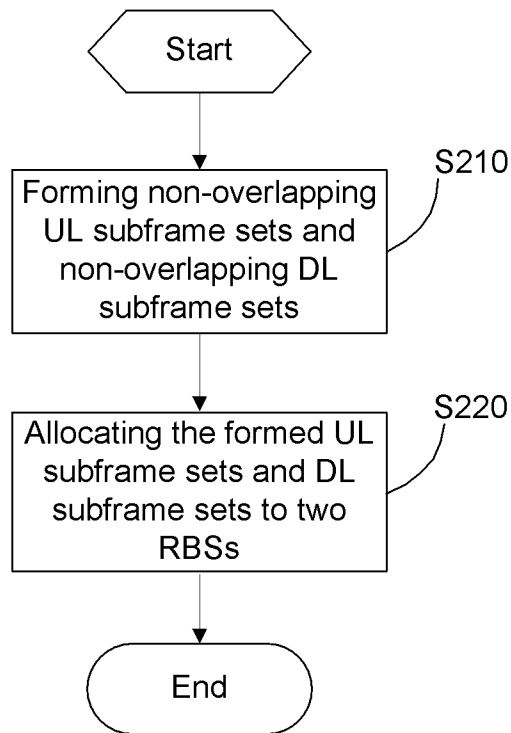

Fig. 2

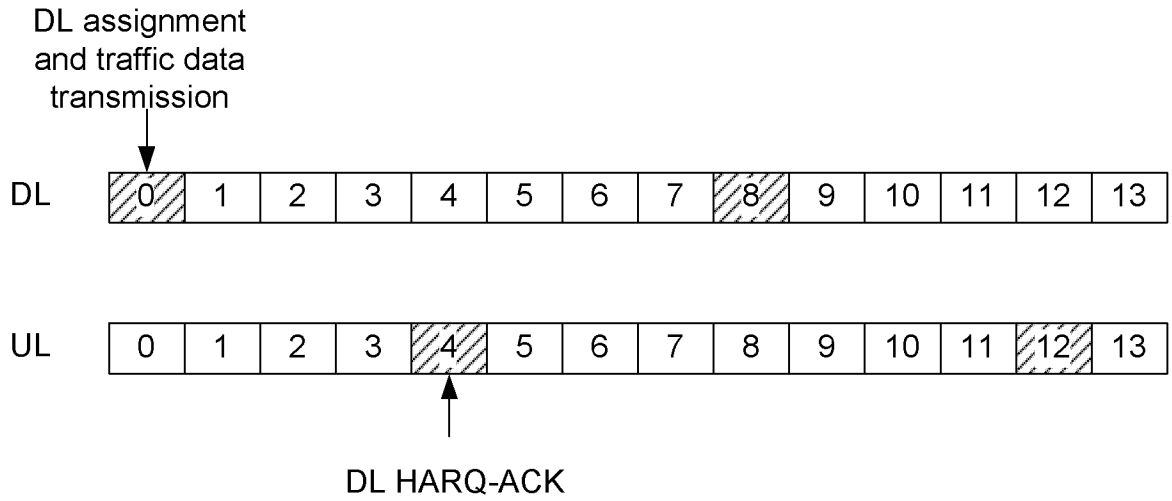

Fig. 3

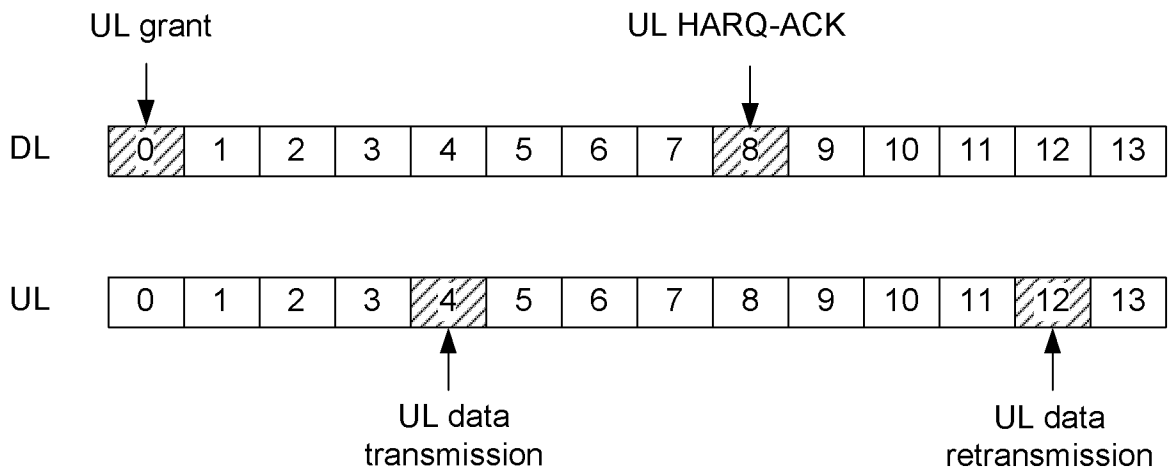

Fig. 4

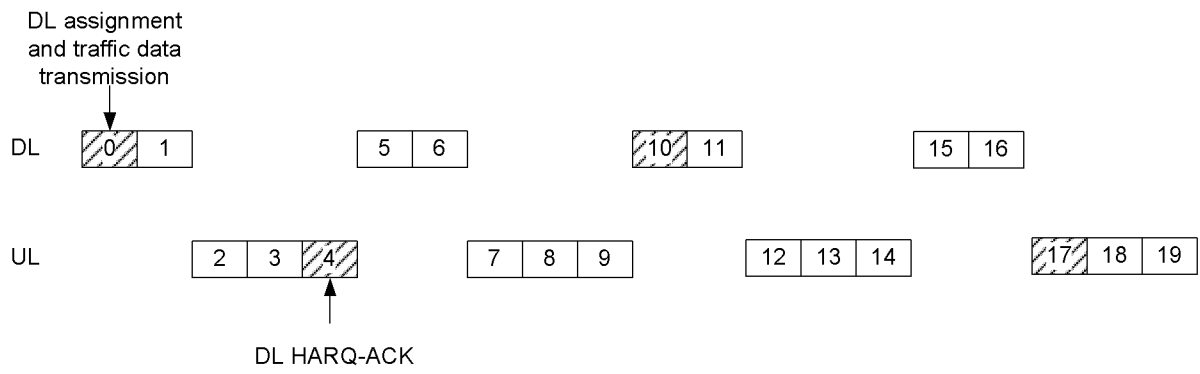

Fig. 5

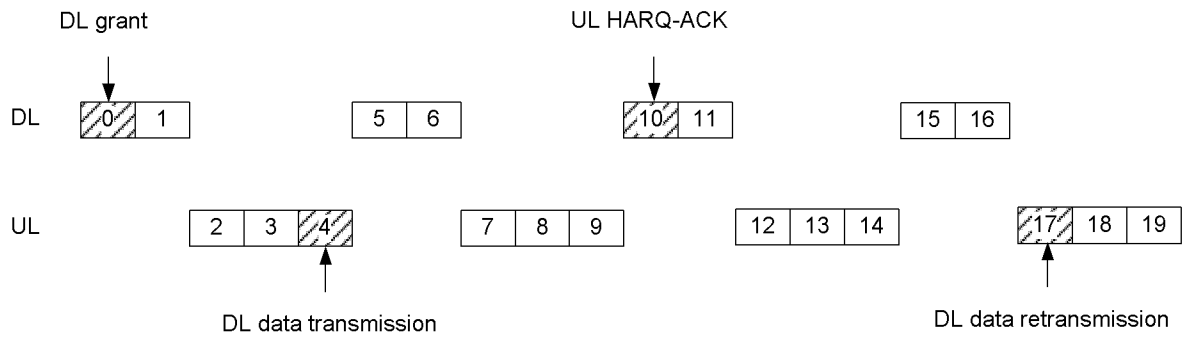

Fig. 6

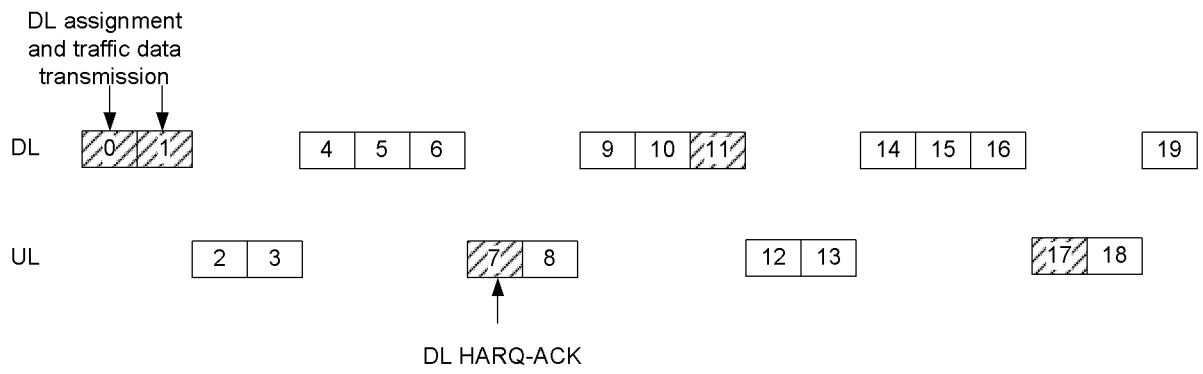

Fig. 7

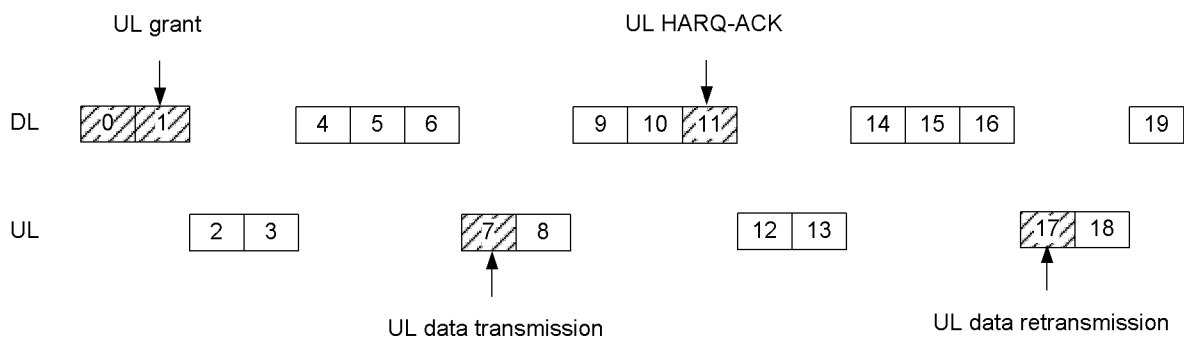

Fig. 8

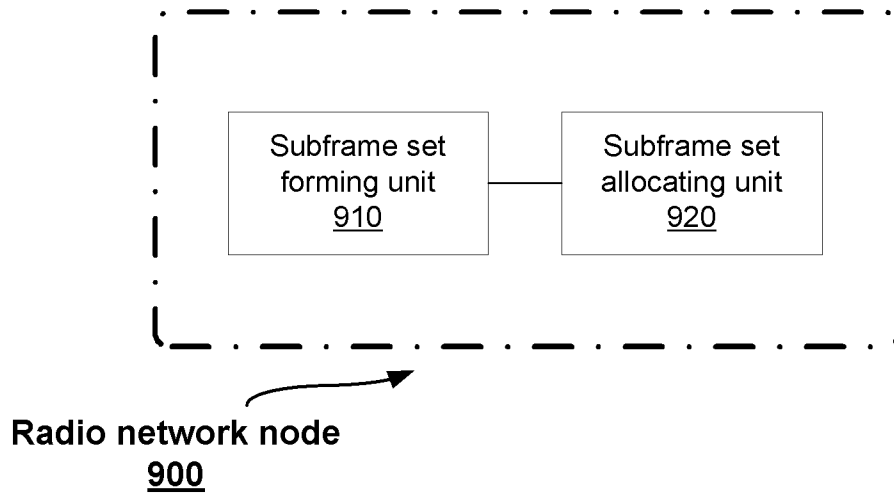

Fig. 9

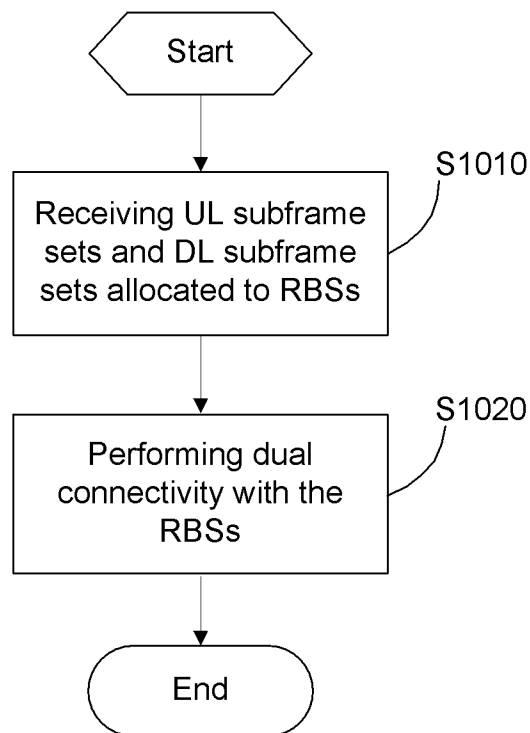

Fig. 10

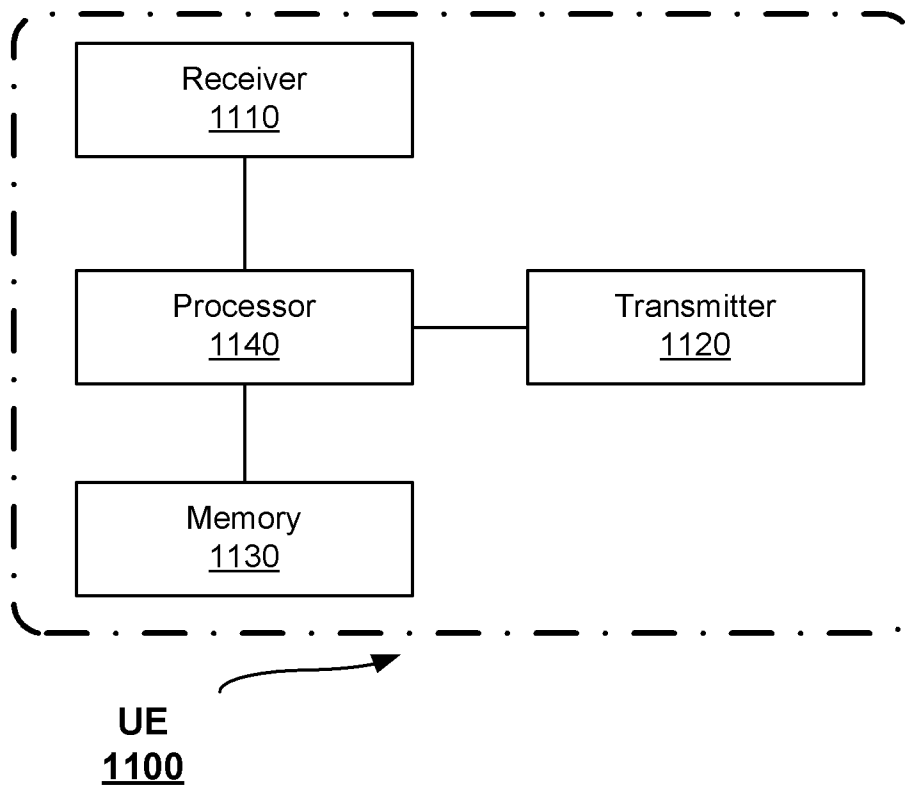

Fig. 11

INTERNATIONAL SEARCH REPORT

International application No.
PCT/CN2013/071191

A. CLASSIFICATION OF SUBJECT MATTER		
H04W 72/04 (2009.01)i		
According to International Patent Classification (IPC) or to both national classification and IPC		
B. FIELDS SEARCHED		
Minimum documentation searched (classification system followed by classification symbols)		
IPC: H04W; H04Q; H04B		
Documentation searched other than minimum documentation to the extent that such documents are included in the fields searched		
Electronic data base consulted during the international search (name of data base and, where practicable, search terms used)		
WPI, EPODOC, CNPAT, CNKI, IEEE: dual connectivity, dual mode, double mode, TDM, resource, time slot, code, frequency, partition, BS, UE, non-overlapping, frame, subframe		
C. DOCUMENTS CONSIDERED TO BE RELEVANT		
Category*	Citation of document, with indication, where appropriate, of the relevant passages	Relevant to claim No.
Y	WO2012/126302A1 (ZTE CORPORATION) 27 Sep. 2012 (27.09.2012) abstract, page 5 lines 2,3,11,12 of description	1-5,16-20
A		6-15
Y	US2012/0071190A1 (INFINEON TECHNOLOGIES AG) 22 Mar. 2012 (22.03.2012) paragraph 106 of description	1-5,16-20
A		6-15
A	CN101562903A (NTT DOCOMO, INC.) 21 Oct. 2009 (21.10.2009) see the whole document	1-20
<input type="checkbox"/> Further documents are listed in the continuation of Box C. <input checked="" type="checkbox"/> See patent family annex.		
* Special categories of cited documents:	“T” later document published after the international filing date or priority date and not in conflict with the application but cited to understand the principle or theory underlying the invention	
“A” document defining the general state of the art which is not considered to be of particular relevance	“X” document of particular relevance; the claimed invention cannot be considered novel or cannot be considered to involve an inventive step when the document is taken alone	
“E” earlier application or patent but published on or after the international filing date	“Y” document of particular relevance; the claimed invention cannot be considered to involve an inventive step when the document is combined with one or more other such documents, such combination being obvious to a person skilled in the art	
“L” document which may throw doubts on priority claim (S) or which is cited to establish the publication date of another citation or other special reason (as specified)	“&” document member of the same patent family	
“O” document referring to an oral disclosure, use, exhibition or other means		
“P” document published prior to the international filing date but later than the priority date claimed		
Date of the actual completion of the international search 25 Feb. 2013 (25.02.2013)	Date of mailing of the international search report 24 Oct. 2013 (24.10.2013)	
Name and mailing address of the ISA/CN The State Intellectual Property Office, the P.R.China 6 Xitucheng Rd., Jimen Bridge, Haidian District, Beijing, China 100088 Facsimile No. 86-10-62019451	Authorized officer TIAN, Tao Telephone No. (86-10)62413581	

INTERNATIONAL SEARCH REPORT
Information on patent family members

International application No.
PCT/CN2013/071191

Patent Documents referred in the Report	Publication Date	Patent Family	Publication Date
WO2012/126302A1	27.09.2012	CN102685714A	19.09.2012
US2012/0071190A1	22.03.2012	DE102011053379A1	22.03.2012
		CN102413573A	11.04.2012
CN101562903A	21.10.2009	None	