

A. CAMPBELL.

Printing Press,

No. 100,598.

Patented March 8, 1870.

Fig. 1.

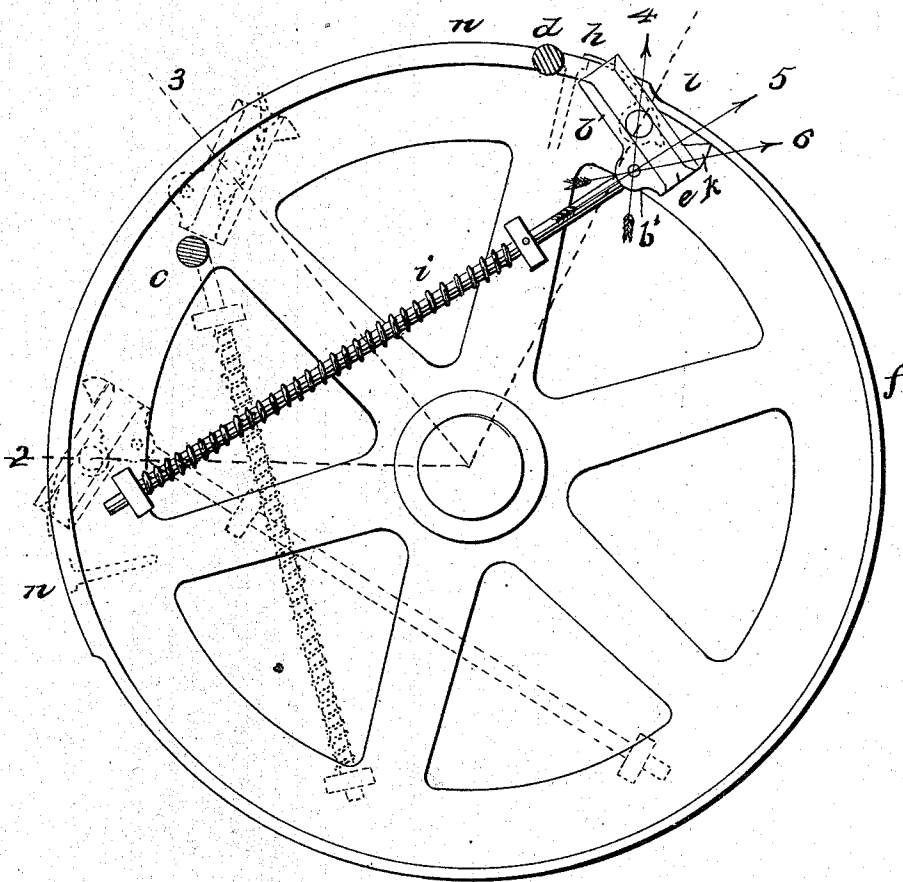

Witnesses:
 Samuel Smith
 Henry Johnston

Inventor:
 A Campbell.
 by Forbush & Hyatt.
 His Attorneys

A. CAMPBELL.
Printing Press.

No. 100,598.

Patented March 8, 1870.

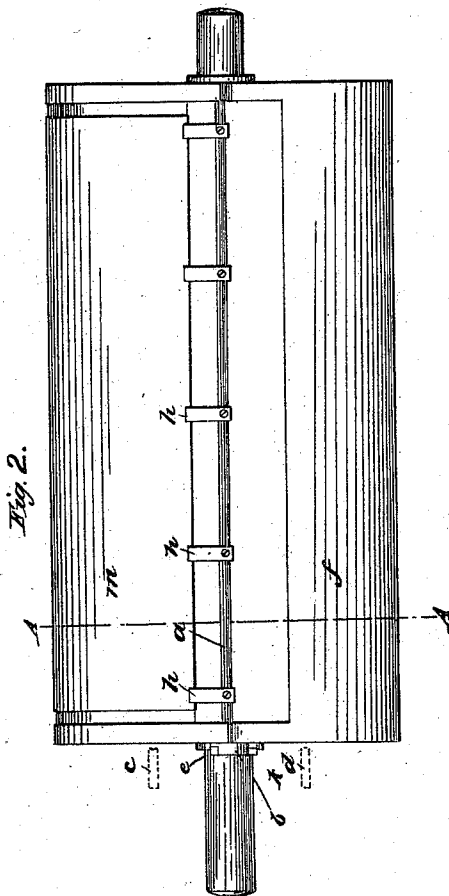
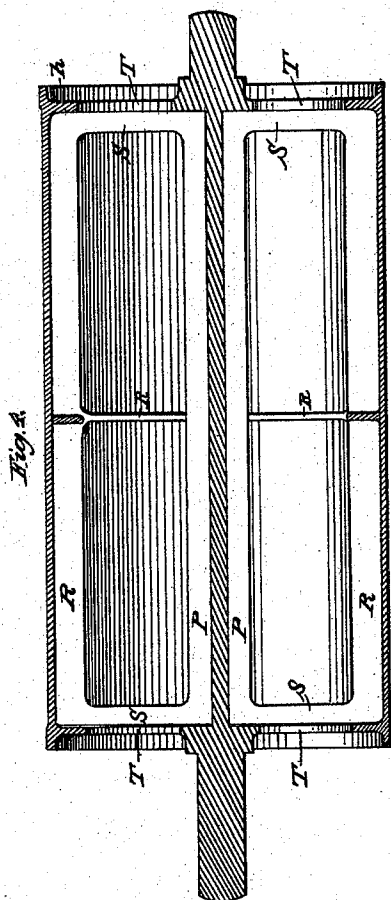

Witnesses:

Amos
Nichaniel Elkan

Inventor:

Amos Campbell

A. CAMPBELL.

Printing Press.

No. 100,598.

Patented March 8, 1870.

Fig. 3.

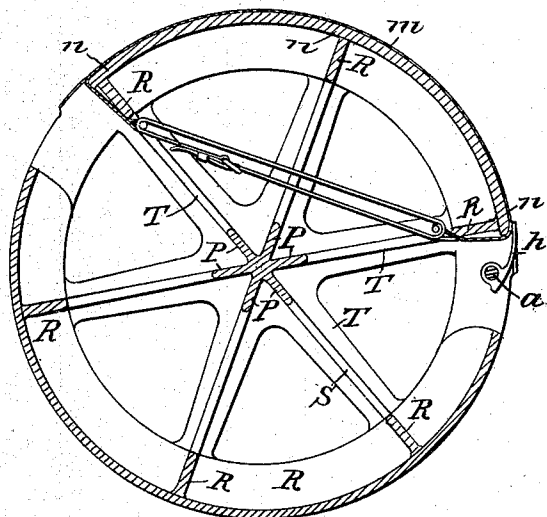
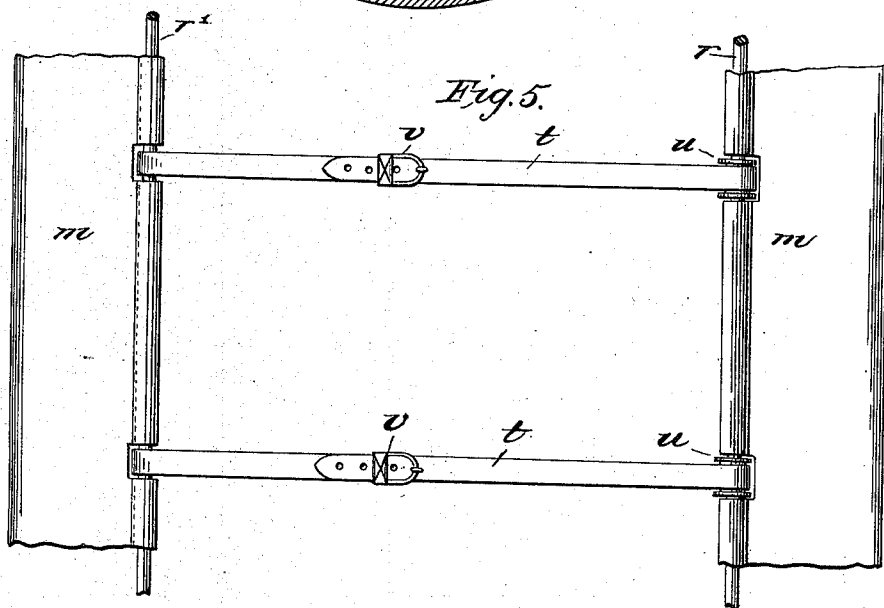

Fig. 5.



Witnesses:

Campbell
Nathaniel Allen

Inventor.

Andrew Campbell

UNITED STATES PATENT OFFICE.

ANDREW CAMPBELL, OF BROOKLYN, NEW YORK.

IMPROVEMENT IN PRINTING-PRESSES.

Specification forming part of Letters Patent No. 100,598, dated March 8, 1870.

To all whom it may concern:

Be it known that I, ANDREW CAMPBELL, of the city of Brooklyn, county of Kings, and State of New York, have invented a new and useful Improvement in the Printing-Press; and I do hereby declare that the following is a full, clear, and exact description of the construction and operation of the same, reference being had to the annexed drawings, making a part of this specification.

Nature and Objects of the Invention.

The first part of my invention relates to the construction of the device employed in "cylinder printing-presses" for operating the fingers which clamp the sheet to the cylinder. In former devices for this purpose it has been common to employ a T-head, fixed upon one end of the finger-shaft, to open and close the fingers by engagement with studs projected from the side framing, a spring-catch being used in connection with such T-head to hold the fingers open or closed, as required.

My improvement consists in the combination, with such T-head, of a stop fixed to the cylinder and a spring-rod or equivalent carried by the cylinder, and pressing against the T-head in a direction neither in line with the axis of the head nor with the stop when the fingers are in their closed position; the object of this construction being the taking up of all lost motion in the joints or bearings of the parts, whether the same occurs from imperfect workmanship or from the wear consequent upon use, and thereby insuring the successive closing of the fingers upon the sheets positively, and in exactly the same place, so as to secure perfect register, this result being due to the direction in which the closing force is applied, and not attainable by any other device of which I have knowledge.

The second part of my invention relates to the manner of securing the "blanket" upon a press-cylinder of that kind in which only a segment of the surface is used for the "impression," and consists in connecting the opposite ends of the blanket together, after the same is applied to the impression-segment, by means of a number of straps passing through the cylinder, and attached to the ends of the blanket at equal distances apart, so that the blanket may be drawn from several points at both ends,

and an equal and uniform tension put upon all parts thereof, which is necessary to the taking of clear and perfect impressions.

The third part of my invention relates to the construction of the cylinder, and consists in strengthening the outer shell by means of radial rectangular frames, of substantially the same thickness as the shell itself, whereby I am enabled to cast the cylinder as a whole in one piece without danger of fracture from unequal shrinkage, and also to obtain that strength and rigidity necessary to the taking of clear and perfect impressions.

General Description.

In the accompanying drawings, Figure 1 is an end elevation of the cylinder, showing also the device for operating the fingers as applied thereto, and Fig. 2 is a plan view of same. Fig. 3 is a cross-section of the cylinder upon line A A of Fig. 2, showing the manner of attaching the blanket, and also the arrangement of the radial frames. Fig. 4 is a longitudinal section of the cylinder. Fig. 5 is a detail view of the means for securing the blanket to the cylinder.

Like letters indicate like parts in each of the figures.

a is the finger-shaft, provided with fingers *b*, and supported in bearings formed in the ends of the cylinder *f*, so that the fingers will lap upon the forward edge of the impression-segment and clamp the sheet thereto in the common manner. To the projecting end of this shaft is fixed the slotted T-head *b*, its angular position with relation to the fingers being such that when they are closed the direction of the slot will form an acute angle to a line passing through the axis of the cylinder and the axis of the finger-shaft.

c and *d* are fixed studs projected from the side frame of the press, and at such distance from the center of the cylinder that as the cylinder revolves (the fingers and T-head being in the closed position, as above described) the stud *c* will strike into the inner end of the slot *e* of the T-head and throw open the fingers, and as the revolution of the cylinder continues the stud *d* will strike into the outer end of said slot and return the fingers to their closed position. The angular distance apart of these studs is regulated by the time required be-

tween the opening of the fingers to release the sheet and their closing to take a new one.

In Fig. 1 the relative positions of the T-head, fingers, cylinder, and studs at the instant the fingers have closed are shown in full black lines. The position of the fingers and T-head as they approach the opening-stud are shown in dotted lines at 2, and their open position at the instant of passing the opening-stud is shown at 3.

i is the spring-rod by which the finger sare held in their open or closed position during the intervals between the action of studs *c* and *d*. It connects to one arm of the T-head by a wrist-joint, as shown at *b'*, and by its action forces the T-head against a fixed stop, K, projecting from the end of the cylinder in both the open and closed positions of the fingers. The direction of this spring-pressure, when the fingers are in their closed position, is such that it neither passes through the axis of the fingers nor through the fixed stop K, as is clearly indicated by the arrows 4, 5, 6. It consequently has the effect to make the fixed stop a fulcrum, from which all lost motion or play in the bearing of the finger-shaft will be taken up and a double bearing for the T-head formed, which will absolutely insure the successive closing of the fingers in exactly the same place upon the cylinder. This closing will also be "positive," with no danger of reaction and letting go of the sheet after the taking, and will be the same under all variations in the speed of the cylinder. The great importance of this certainty and accuracy in the taking of the sheet to secure perfect "register" when it is to be submitted to more than one impression is sufficiently obvious.

n n is the impression-segment of the cylinder. It is disconnected from the balance of the cylinder, except at the ends, by longitudinal slots, and the cylinder is made without internal arms, so that the appliances for securing the blanket may be readily manipulated.

m represents the blanket, its ends turning over the sides of the impression-segment and projecting into the cylinder.

Extending across each end of the blanket, and secured thereto, is a rod, *r'*, and reaching from rod to rod, through the cylinder, are the straps *t*, by which the blanket is secured in place.

The connection of the rods to the blanket is

effected by doubling its ends over them, and sewing them back upon itself, or in any other equivalent and convenient manner.

The straps *t* pass around the rods through notches cut in the blanket, and their ends are united by buckles *v v*, so that by drawing upon either strap the part of the blanket with which it connects may be placed and secured under any required tension.

The drawing of the blanket from both ends secures a non-uniform tension in the circular direction, and the drawing from several points in its axial length secures the same result in that.

The cylinder *f* is constructed as follows: R S P are rectangular radial frames, six or more in number, the sides P of which meet at the center and form a ribbed shaft, and the sides R of which bear against the outer shell and support and stiffen the same.

The ends S connect with radial arms T, from whose centers project the turned journals upon which the cylinder rotates.

It will be observed that this formation makes all parts of the cylinder of substantially the same thickness, which enables me to cast it as a whole in one piece without danger from unequal shrinkage, and that the internal ribbing of the outer shell and the ribbed form of the shaft give great strength and rigidity, which are vital requirements in the doing of good work.

Having thus described my invention, what I claim is—

1. The combination, with the T-head upon the finger-shaft, of a fixed stop, K, upon the cylinder, and a pressure-spring, *i*, so arranged as to exert its force in a direction out of line with both finger-shaft and stop, as and for the purposes hereinbefore set forth.

2. Securing the blanket to the impression-segment by means of a number of straps, *v*, drawing from both ends of the blanket, and at regular intervals in its length, as and for the purposes hereinbefore set forth.

3. A printing-press cylinder strengthened by a series of radial rectangular frames, S, and as a whole cast in one piece, as and for the purposes hereinbefore set forth.

ANDREW CAMPBELL.

Witnesses:

G. W. HALL,
NATHANIEL ELKIN.