

March 1, 1927.

1,619,708

H. T. DIETRICK

COMBINED RECEPTACLE OPENER AND FLUID CONDUCTOR

Filed Oct. 28, 1925

Fig. 1.

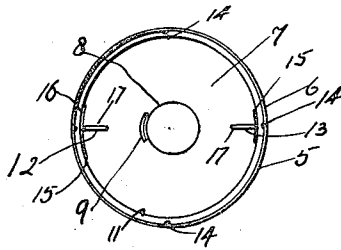

Fig. 2.

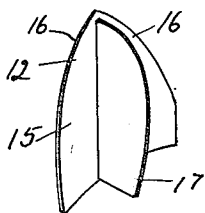
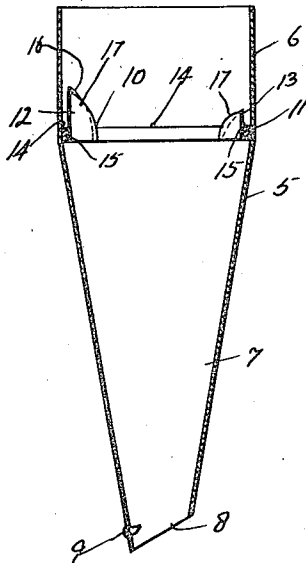

Fig. 3.

INVENTOR

Herman T. Dietrick

By *W. B. Williamson* Atty

UNITED STATES PATENT OFFICE.

HERMAN T. DIETRICK, OF PHILADELPHIA, PENNSYLVANIA.

COMBINED RECEPTACLE OPENER AND FLUID CONDUCTOR.

Application filed October 28, 1925. Serial No. 65,329.

My invention relates to new and useful improvements in a combined receptacle opener and fluid conductor and has for its primary object to provide an exceedingly simple and effective device of this character whereby a sealed receptacle may be inserted in the device, and by the use of sufficient pressure in the proper direction will open said receptacle and cause the liquid or fluid to be conveyed or conducted from the receptacle to the desired location or device to receive the fluid or liquid.

Another object of the invention is to combine in one structure means for opening a receptacle containing a fluid or liquid and means to direct said liquid or fluid to some suitable point.

A device of this character is particularly adapted for use in filling automobile crank cases and the like with a desirable lubricating oil because it insures the use of the lubricant desired by the automobile owner or operator as well as making the filling operation a clean and easy one. Under present conditions the crank case of an engine is generally filled with a funnel or by a receptacle having a long spout or thru the medium of a tube fastened to a cap which latter is screwed on to a glass jar or the like. In such cases the receptacle has to be filled by the person using the same, and where such person is the attendant of a service station it is an easy matter to substitute an inferior lubricating oil for one of a better grade which may have been requested, thereby making it possible for some one to receive a greater profit. These disadvantages are entirely overcome by the use of my device as the lubricating oil may be packed in sealed cans or receptacles which are only opened when inserted in the device and the oil conveyed directly to the point of use or distribution, thereby preventing or reducing to a minimum the possibility of substitution of one oil for another.

With these ends in view, this invention consists in the details of construction and combination of elements hereinafter set forth and then specifically designated by the claims.

In order that those skilled in the art to which this invention appertains, may understand how to make and use the same, I will describe its construction in detail, referring by numerals to the accompanying drawings forming a part of this application, in which:

Fig. 1 is a plan or upper end view of a combined receptacle opener and fluid conductor, illustrating one structure for carrying my invention.

Fig. 2 is a longitudinal sectional view thereof.

Fig. 3 is an enlarged perspective view of one form of cutter or opener for unsealing a receptacle.

In carrying out my invention as herein embodied, 5 represents a fluid conductor which may be of any desirable shape, although preferably tubular with a cylindrical upper end 6 and a conical lower end 7, the walls of which converge toward the lower end where they terminate on an oblique line at the outlet 8. This fluid conductor is to be used like a spout or funnel or in other words, its outer end is to be inserted into the filling opening of the device which is to receive the fluid or liquid from a receptacle, and in order to assist the user in steadying the conductor, a rib or offset 9 may be provided adjacent the outlet end to engage the rim of the filling opening of the object being supplied with the liquid or fluid.

Within the fluid conductor, and preferably in the cylindrical portion 6 thereof is mounted a receptacle opening device 10, which may be of any desired construction best suited for the unsealing operations according to the character of the seal used on the receptacle carrying the liquid or fluid.

As an illustration of one means for carrying out the unsealing operations I have shown the unsealing device as including a ring 11, which acts as a support for cutters 12 and 13, the latter being situated at suitable places about the ring, or more particularly, the interior of the fluid conductor, so that at least one will be in a position to admit air into the receptacle, and another in the position to permit easy egress of the liquid or fluid from the receptacle, and as the device is generally used in an inclined position, one of the cutters would be above the liquid level and another at the lowest point of said liquid. As here shown, the cutters may be of different lengths, the cutter 12 which makes the opening for the outlet of the liquid or fluid being the longer one, and of course, it will be obvious that any de-

sirable number of these cutters may be utilized, altho only two are herein shown. It is also desirable that the cutters be removable, and to this end the supporting member or ring 11 for said cutters has been shown as slidable in the cylindrical portion 6 of the fluid conductor with teats or small projections 14 formed from the cylindrical portion of the fluid conductor, whereby some force will be required to remove or replace the cutters.

As shown herein, the cutters each include a blade 15, having two cutting edges 16 diverging from their upper meeting ends and which blade is transversely arcuate. On the vertical center of the blade is located what I term a spreader cutter 17, so that as the metal of the receptacle holding the fluid or liquid is cut, the spreader cutter will cause the free metal of the receptacle top to be spread apart which will then tend to roll back or coil upon itself, so as to produce a goodly sized opening.

In actual practice when the crank case of an engine or other device is to be supplied with a lubricator or other liquid or fluid, the fluid conductor is placed in the filling opening and the receptacle containing the oil, fluid or liquid is inserted in the cylindrical portion 6, and then sufficient pressure is brought to bear thereon so that the cutting devices will form incisions, cut or unseal the receptacle, and as soon as this has been done, the fluid or liquid will begin to flow from the receptacle thru the fluid conductor into the device being supplied; therefore the fluid or liquid is unlikely to be contaminated by surrounding foreign matter and, as before stated, the customer will be assured that the proper and desired merchandise is being furnished, and after the receptacle has once been emptied, the mutilation thereof during the opening process will prevent its repeated use by dishonest per-

sons intent upon deceiving or defrauding the public for the purpose of deriving greater profits.

Of course I do not wish to be limited to the exact details of construction as herein shown as these may be varied within the limits of the appended claims without departing from the spirit of my invention.

Having thus fully described my invention, what I claim as new and useful is:

1. In a device of the character stated, a tubular member having a cylindrical portion and a conical portion, the conical portion having its walls converging toward the outer end, a rib adjacent said outer end, a supporting member removably mounted in the cylindrical portion of the said member and resting against the conical portion thereof, means to retain the supporting member against accidental displacement and can-opening devices carried by the supporting member.

2. In a device of the character stated, a can opener adapted to be removably supported at the larger end of a tapering supporting member and comprising a blade having two cutting edges diverging from their outer meeting ends and said blade being transversely arcuate, and a spreader-cutter on the vertical meeting line of the blade.

3. The combination with a substantially funnel-shaped device having a cylindrical portion formed at its larger end, of can-opening devices with the cylindrical portion of the device, and a ring within the cylindrical portion supporting the can-opening devices from the line of intersection between the cylinder and funnel-shaped portions of the device.

In testimony whereof, I have hereunto affixed my signature.

HERMAN T. DIETRICK.