

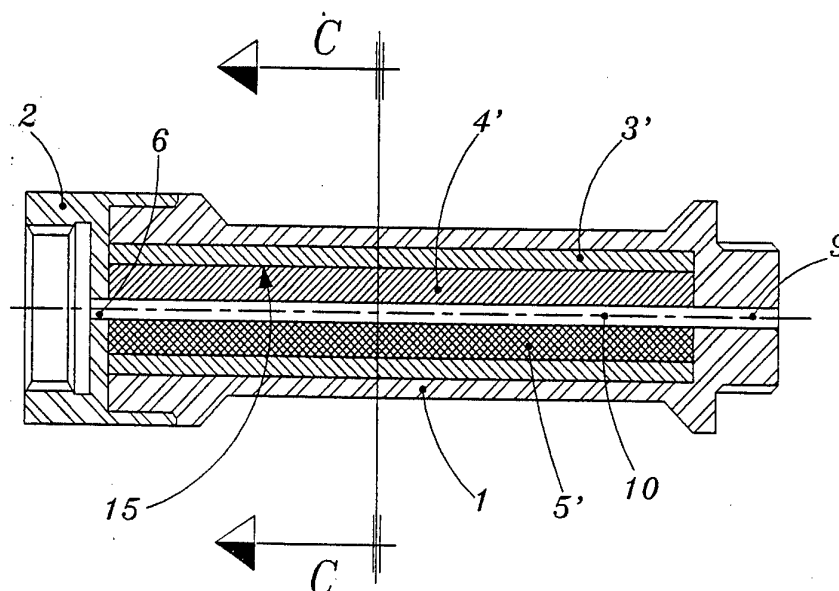

INTERNATIONAL APPLICATION PUBLISHED UNDER THE PATENT COOPERATION TREATY (PCT)

<p>(51) International Patent Classification ⁵ : C02F 1/48, 5/00</p>	<p>A1</p>	<p>(11) International Publication Number: WO 94/03400 (43) International Publication Date: 17 February 1994 (17.02.94)</p>
<p>(21) International Application Number: PCT/IT93/00088 (22) International Filing Date: 4 August 1993 (04.08.93)</p> <p>(30) Priority data: BS92A000098 7 August 1992 (07.08.92) IT BS93A000072 17 June 1993 (17.06.93) IT BS93A000079 14 July 1993 (14.07.93) IT</p> <p>(71) Applicant (for all designated States except US): CIMA S.R.L. [IT/IT]; Via Celesti, 33/B, I-25081 Bedizzole (IT).</p> <p>(72) Inventor; and (75) Inventor/Applicant (for US only) : CIMA, Rolando [IT/IT]; Via Celesti, 33/B, I-25081 Bedizzole (IT).</p>		<p>(81) Designated States: AU, BG, BR, CA, CZ, FI, HU, JP, NO, PL, RO, RU, SK, UA, US, European patent (AT, BE, CH, DE, DK, ES, FR, GB, GR, IE, IT, LU, MC, NL, PT, SE).</p> <p>Published <i>With international search report.</i> <i>Before the expiration of the time limit for amending the claims and to be republished in the event of the receipt of amendments.</i></p>

(54) Title: ANTI-CALCAREOUS MAGNETIC WATER CONDITIONER, WITH IMPROVEMENTS WHICH BRING ABOUT ALTERNATIVE SOLUTIONS



(57) Abstract

The object of this invention is a new conditioner apparatus fit to transform the physical characteristics of the water, as it is able to determine the suspension of the lime, present in said water, without allowing it to settle as solid scaling along the walls of the pipes, of boilers and the like. The said apparatus is composed of two parallelepiped magnetic elements (4, 5), enclosed in a different way in an iron tubular casing (3), making to ensure that the water, which is forced to flow through the spaces in between these, undergoes the aforementioned physical transformations, as they are forced to pass through the magnetic field formed by them.

FOR THE PURPOSES OF INFORMATION ONLY

Codes used to identify States party to the PCT on the front pages of pamphlets publishing international applications under the PCT.

AT	Austria	FR	France	MR	Mauritania
AU	Australia	GA	Gabon	MW	Malawi
BB	Barbados	GB	United Kingdom	NE	Niger
BE	Belgium	GN	Guinea	NL	Netherlands
BF	Burkina Faso	GR	Greece	NO	Norway
BG	Bulgaria	HU	Hungary	NZ	New Zealand
BJ	Benin	IE	Ireland	PL	Poland
BR	Brazil	IT	Italy	PT	Portugal
BY	Belarus	JP	Japan	RO	Romania
CA	Canada	KP	Democratic People's Republic of Korea	RU	Russian Federation
CF	Central African Republic	KR	Republic of Korea	SD	Sudan
CG	Congo	KZ	Kazakhstan	SE	Sweden
CH	Switzerland	LI	Liechtenstein	SI	Slovenia
CI	Côte d'Ivoire	LK	Sri Lanka	SK	Slovak Republic
CM	Cameroon	LU	Luxembourg	SN	Senegal
CN	China	LV	Latvia	TD	Chad
CS	Czechoslovakia	MC	Monaco	TG	Togo
CZ	Czech Republic	MG	Madagascar	UA	Ukraine
DE	Germany	ML	Mali	US	United States of America
DK	Denmark	MN	Mongolia	UZ	Uzbekistan
ES	Spain			VN	Viet Nam
FI	Finland				

DESCRIPTION:"ANTI-CALCAREOUS MAGNETIC WATER CONDITIONER, WITH
IMPROVEMENTS WHICH BRING ABOUT ALTERNATIVE SOLUTIONS"1 TECHNICAL FIELD-

The above mentioned invention is a new instrument with magnetic properties, for application to water works so that it will enable the water to reach the areas where it is to be used, without scaling pipes and tanks.

5

TECHNICAL POSITION-

At the moment, among the many known anti-calcareous magnetic water conditioning instruments, there is one which has been studied and perfected and which is capable of equipping the water works which convey the water where it is to be used. Many are the instruments which have been

10

manufactured, and all of them are in more or less a position to carry out their function of intercepting the water which is made to pass through them.

This new instrument has also been studied and tested in order to avoid the difficulties which create many inconveniences to the water works, without using complex and costly procedures, and without using chemical substances and connections to sources of electric energy.-

15

AIMS AND ADVANTAGES OF THE INVENTION-

The action of the above mentioned water conditioner suspends all the needle-like particles floating in the water which are inevitably transported by it. This avoids these particles from gathering together on the surface of containers and piping, thus transforming the mineral salts contained in the water, from $Ca(HCO_3)_2$ (calcium hydrate carbonate or bicarbonate), to $CO_2 + H_2O + CaCO_3$ (calcium carbonate, a sub-form of calcite); this avoids the formation of calcareous deposits and the consequent partial or total occlusion of the pipes and the loosening of the scales which damage, pipes, taps, valves and reservoirs.

20

25

The above mentioned water conditioner, has the following advantages:

-Fitted to pipes, it creates a sole efficient point for the treatment of cold or hot water.

30

- 1 -It protects everything that contains, controls or intercepts water
movement against the formation of scales, improving the thermal efficiency of
the water work.
- 5 -In swimming pools and in spas it favours the diffusion of chemical reagents,
improving their bacteriological efficiency.
- In water boilers and home appliances, it avoids the formation of scales,
and the use of detergents for their periodical cleaning.
- It is easily assembled because it is composed of a few simple parts which are
easy to use and to put together.
- 10 It is easily fitted to machines and water works.
- It can be placed next to equipment which does not tolerate the proximity
of magnets, since it doesn't cause any difficult situations.
- It has been created to obtain relevant results regarding the water to be treated
at high degrees of scales abatement, both due to its ability and abatement
15 speed.
- It doesn't require any maintenance, cleaning, or spare parts.
- Using the alternate solutions projected for its manufacture, its production and
assembly are made that much easier.

20 **DRAWINGS-**

In order to define better this invention, a description thereof, in greater
detail, and drawn up according to a chosen criterion, will now follow, as an
example, which is neither binding nor limiting and which refers to the drawings
of:

25 FIG. 1 - Water conditioner shown as it appears when it is not fitted to the
pipes;

FIG. 2 - the same, fitted with distance sleeve, seen during completion of
the assembly;

30 FIG. 3 - BB section of the water conditioner with distance sleeve, as per
marking on FIG. 4;

FIG. 4 - AA section of the water conditioner with distance sleeve as
indicated under FIG. 3;

FIG. 5 - water conditioner with isolators, executed as an alternative to the
first and viewed while its assembly is being completed;

35 FIG. 6 - DD section of the water conditioner with isolators, as per

1 marking on FIG. 7;

FIG. 7 - CC section of the water conditioner with isolators, as indicated under FIG. 6;

5 FIG. 8 - water conditioner complete with protruding elements and bevelled off in other cases, executed as an alternative to the first, and viewed while its assembly is being completed;

FIG. 9 - FF section of the water conditioner as viewed in the previous drawing, as per marking on FIG. 10;

FIG. 10 - EE section of the water conditioner indicated under FIG. 9;

10 FIG. 11 - water conditioner with two parts internal casing, executed as an alternative to the previous ones, and viewed as its assembly is being completed;

FIG. 12 - HH section of the water conditioner with two parts internal casing, as per marking on FIG. 13;

15 FIG. 13 - GG section of the water conditioner with two parts internal casing, indicated under FIG. 12;

FIG. 14 - it shows the position taken by the two parts which make up the internal casing in relation to the rectangular ring, the two magnetic elements and the external casing.

20 All the figures emphasise the structure of the above mentioned water conditioner created so as to be fitted to rigid, or flexible pipes. When studying FIGURES. 1, 2, 3 and 4, one notices that the casing of cable 1 which is made of anti-magnetic metal, or in plastic material, is provided with two equal and parallel planes, which lighten it and are a characteristic thereof. It contains all
25 the necessary elements for the functioning of the water conditioner, which is closed by cap 2, also made of plastic material or anti-magnetic metal, and which, moreover, closes and tightens together all the internal components, keeping them in contact. Cap 2 may be fitted to the casing of cable 1 through a thread, a trip stop coupling, or even through welding.

30 Cable casing 1 and cap 2 are completed through screw tap or groove threading 7 and 8 according to the need, so as to join the apparatus to the tubes or pipes of various kinds.

Iron metallic tubular casing 3 is fitted to the cavity of casing 1
and acts as a screen for the parts enclosed in it. These are the parallelepiped
35 magnetic elements 4 and 5.

1 The metallic tubular casing 3, which is opened at both ends, contains
magnetic elements 4 and 5 which must always be fitted into it, as shown in the
figures; these must also be put in a condition of reciprocal attraction, so as to
5 be able to interconnect if free to do so without the interference from external
pressures to guide them, so that the two surfaces, which come into contact,
may unite perfectly. The planes of these two elements, which tend to be
attracted to one another, are kept apart by distance sleeve 26, composed of a
stainless plate, corrugated and punctured, or with a stainless steel net, both
10 able to create the transit channel 10, which is necessary for the water to be
treated and which must transit through the water conditioner.

Distance sleeve 26 keeps magnetic elements 4 and 5 separate. It is kept
still by the force of attraction which is created by them reciprocally and which
creates transit channel 10, through which the water to be treated is forced to
pass.

15 The metallic tubular casing 3, which guarantees a perfect external
isolation for elements 4 and 5, allows these to create the necessary magnetic
field which influences the water while this passes through transit channel 10.
For these reasons it is possible to effect within channel 10, the physical
transformation of the lime contained in the water, which is put in suspension
20 and it will be impossible for it to stick to the walls of the pipes into which the
water flows.

Figures 5, 6, and 7 show the water conditioner as an alternative to the
first one, which deals with the metallic tubular casing 3, in rectangular section
as well, where its walls 13 are thinner than those of walls 14, see figures 5 and
25 7, as, in its cavity 15, over and above the magnetic elements 4 and 5, equally
parallelepiped and perfectly equal among themselves, there are also two
isolator elements 12 contained therein, which, through protrusion 11, maintain
separate and perfectly arranged magnetic elements 4 and 5 as indicated under
figure 5. The said conformation of the parts, helps the arrangement of the
30 elements at the time of their assembly, considering, also in this case, and as
said before, that the magnetic elements 4 and 5 must always be put and
positioned into the metallic tubular casing 3 as previously said.

The two magnetic elements, which are kept separate from protrusions 11
of the isolator elements 12, always create transit channel 10 and for this
35 reason: they simplify the assembly phases of the water conditioner; the

1 chances increase that the above mentioned needle-like, floating particles, will
not unite on the surfaces inside the pipes of the reservoirs through which the
water passes.

5 The passing of the water through the water conditioner is always
guaranteed by apertures 6 and 9 executed on cap 2 and on the cable casing 1,
as these possess sections which are adequate to the situation.

10 FIGURES 8, 9 and 10 show the action of the water conditioner as an
alternative to the previous ones. This happens through the effect of the slanted
protrusions 17, 18, 19 and 20, in cable casing 1' and cap 2' through the relevant
beveling effected in relation to the magnetic elements 4" and 5". Protrusions
and beveling must be coupled in order, to obtain an easier execution and a
faster assembly of the apparatus with the simplification of isolating elements
12', put and positioned into the metallic tubular casing 3'.

15 FIGURES 11, 12, 13, and 14, show a new solution, for the particular
conditioning of water as an alternative to the previous ones and are the result
of a further perfecting, where the external casing 29 contains and guides the
internal metallic casing composed of two metallic elements 21 and 22, thus
presenting the new solution, as when united and composed, they make up the
tubular casing guided by finning 23 and 24, as produced in the core 25 of
20 casing 29. Furthermore, the same finning 23 and 24, protrude from the metallic
casing towards the inside, also guiding elements 4 and 5, carrying out and
defining transit channel 10, destined to the passage of the water to be treated,
as indicated under FIG. 13, executed according to the measurements of
apertures 6 and 9 of casing 29 and of cap 2.

25 Elements 21 and 22, which from the internal casing for the magnetic
elements 4 and 5, are equal to each other; they have walls of a constant
thickness; they can be obtained through shearing, and bending of the
rectangular plates; they can be easily and perfectly fitted.

This makes assembling of the whole apparatus easier.

30 According to this condition the deriving instrument, would not be in a
position to obtain the required result, as it should function without the iron
tube which constitutes the required magnetic field. Therefore, in order to
obtain the required magnetic field, and by using elements 21 and 22, it has
been arranged to unite them on contact, by fitting iron ring 27, as shown in
35 FIGURES 11 and 12. This closes and completes the magnetic field remaining

- 6 -

1 solidly united to elements 4 and 5 for the pushing which activates cap 2.

 The anti-calcareous magnetic water conditioner, which is the object of
the invention, and the perfected models which have been described, carry
out all the same prerogatives in relation to the water that flows into their
5 channels 10.

CLAIMS

- 1 1. **Anti-calcareous magnetic water conditioner; composed of elements 4**
and 5; metallic tubular element 3; cable tubular casing 1, closed by cap 2; It is
characterised by the fact that elements 4 and 5 are magnetic, parallelepiped
and equal, and put into casing 3 so as to be attracted and reciprocally united
5 (assuming, logically, that they are left free from stops and other bonds).
2. **Magnetic water conditioner; as per claim 1; characterised by magnetic**
elements 4 and 5 which, put into the seat of the metallic tubular casing 3, kept
apart by distant sleeve 26, so as to obtain the required magnetic field and
transit channel 10 for the passage of the water to be treated.
- 10 3. **Magnetic water conditioner; as per claims 1 and 2; characterised by**
elements 4 and 5, fitted longitudinally in tubular casing 3 with their axes
parallel to the axis of the same.
4. **Magnetic water conditioner; as per claims 1, 2 and 3; characterised by**
metallic tubular casing 3, executed in iron to contain elements 4 and 5 so that
15 they can create the required and isolated magnetic field, avoiding in this
manner dispersions towards the exterior.
5. **Magnetic water conditioner; as per claims 1, 2, 3, and 4;**
characterised by cable tubular casing 1 and by cap 2, which closes it, executed
in plastic material or in non-ferrous metal.
- 20 6. **Magnetic water conditioner; as per claims 1, 2, 3, 4 and 5; characterised**
by the protrusions 11 of elements 12, which keep apart magnetic elements 4"
and 5", arranged in casing 3', from walls 14 and 13 of varying thickness.
7. **Magnetic water conditioner; as per claims 1, 2, 3, 4 and 5; characterised**
by the slanted protrusions 17, 18, 19, and 20 of cable tubular casing 1' and by
25 cap 2', coupled together with as many bevels executed in magnetic elements 4'
and 5' so as to create transit channel 10 and the required magnetic field.
8. **Magnetic water conditioner; as per claims 1, 2, 3, 4 and 5; characterised**
by the distance sleeve elements 12 or 12', executed in plastic material, so as to
create the required isolation among magnetic elements 4', 5', 4" and 5", into
30 metallic tubular casing 3'.

1 9. Magnetic water conditioner; as per claims 1, 2, 3, 4 and 5; characterised
by the two elements 21 and 22 which, together with ring 27, execute a sole
magnetic field, as they wind round elements 4 and 5.

5 10. Magnetic water conditioner; as per claims 1, 2, 3, 4 and 5;
characterised by finning 23 and 24 protruding from its inside as these keep
apart, over and above the two elements 21 and 22, also elements 4 and 5 which
are contained by them.

10

FIG. 5

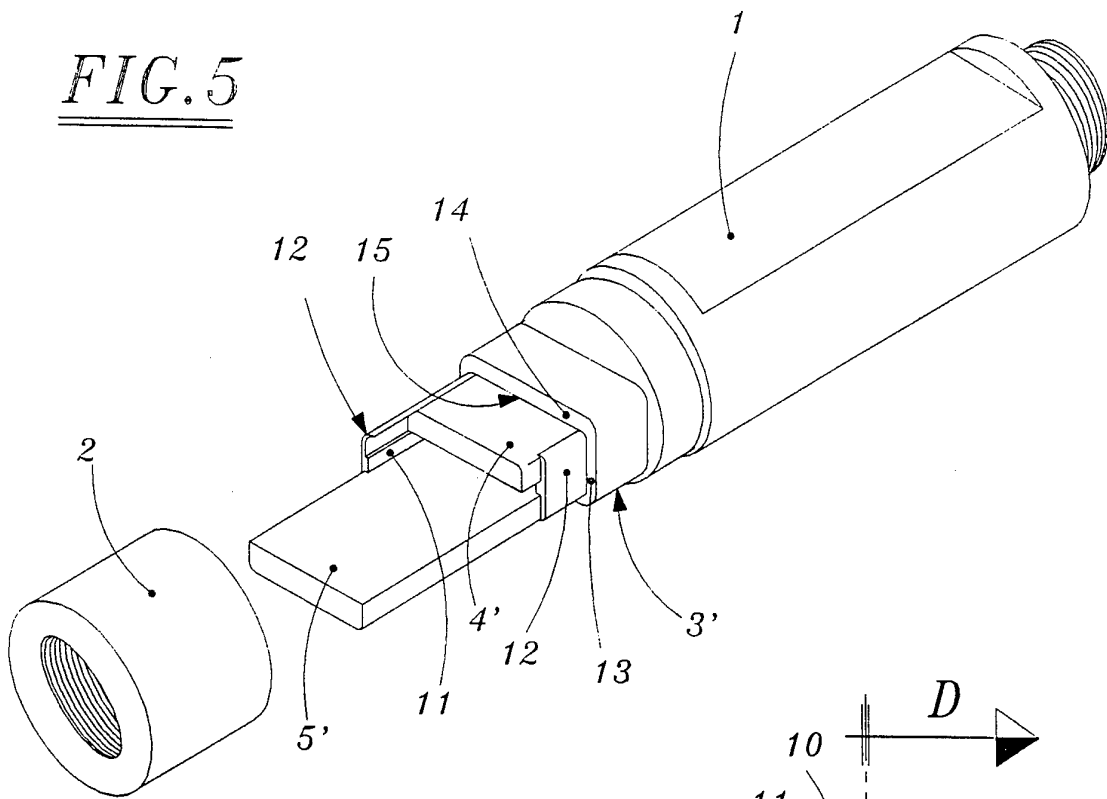

FIG. 7

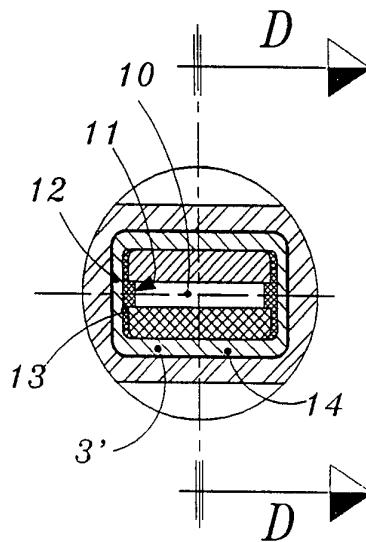
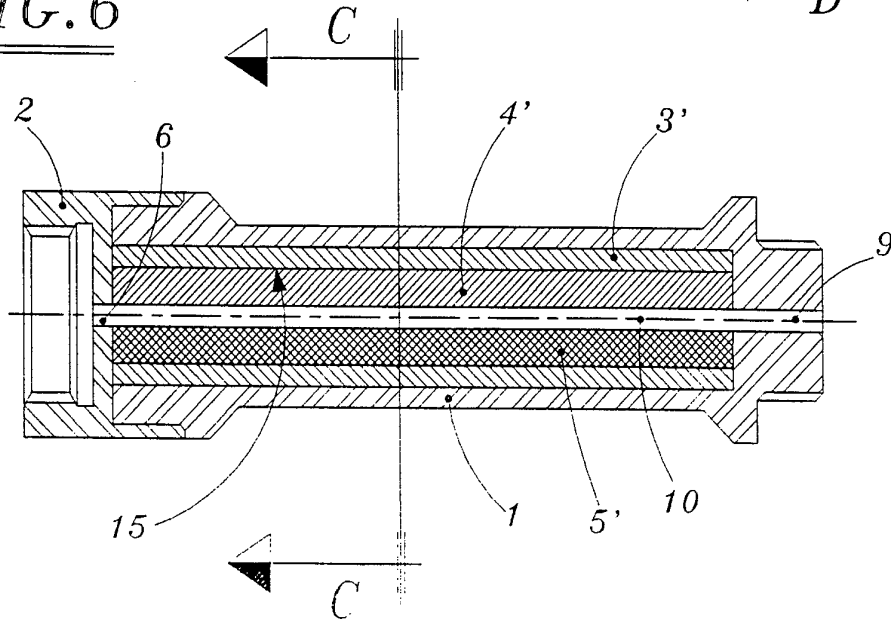

FIG. 6



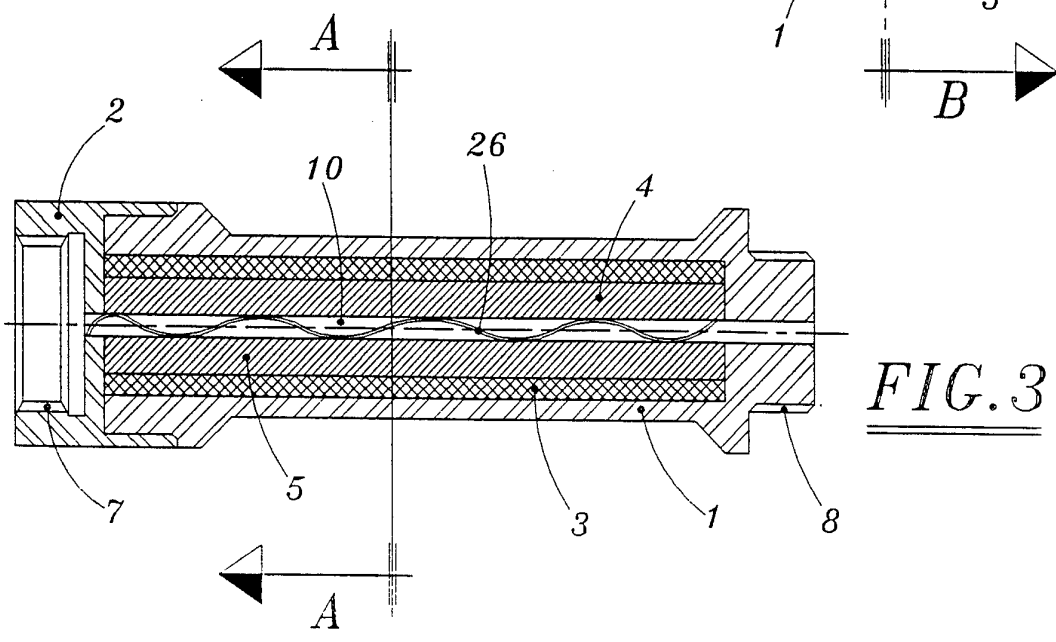
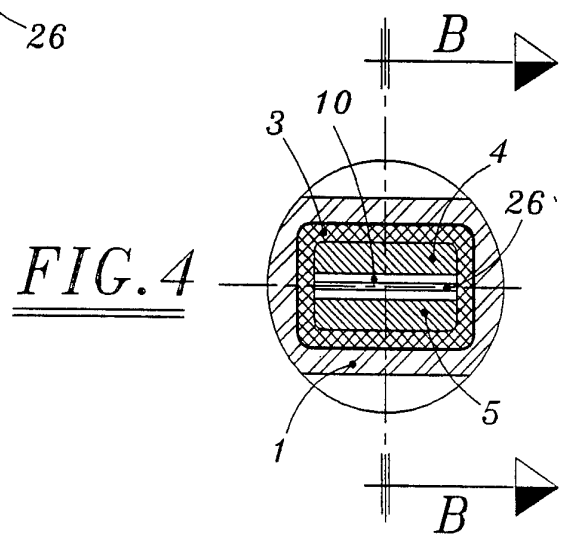
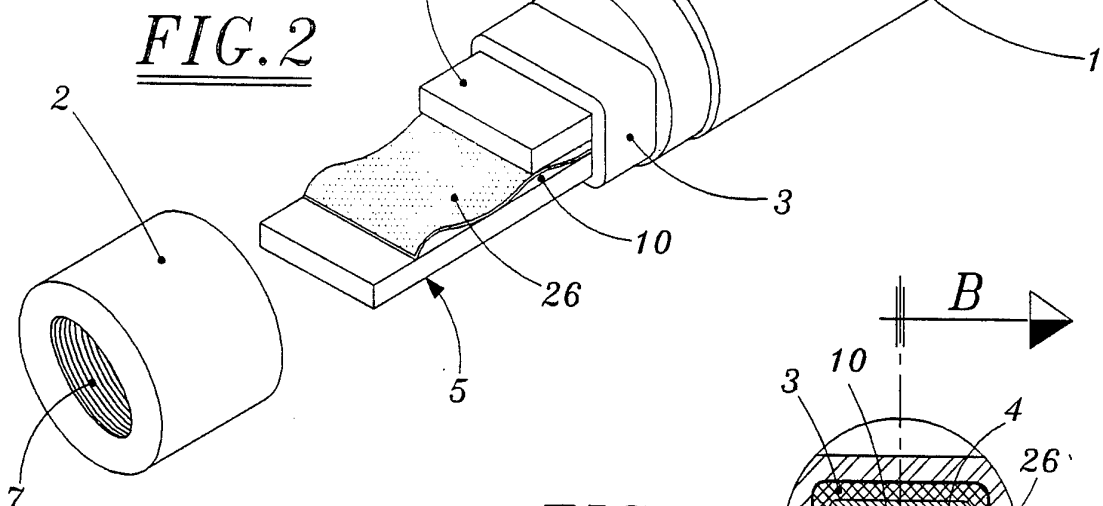
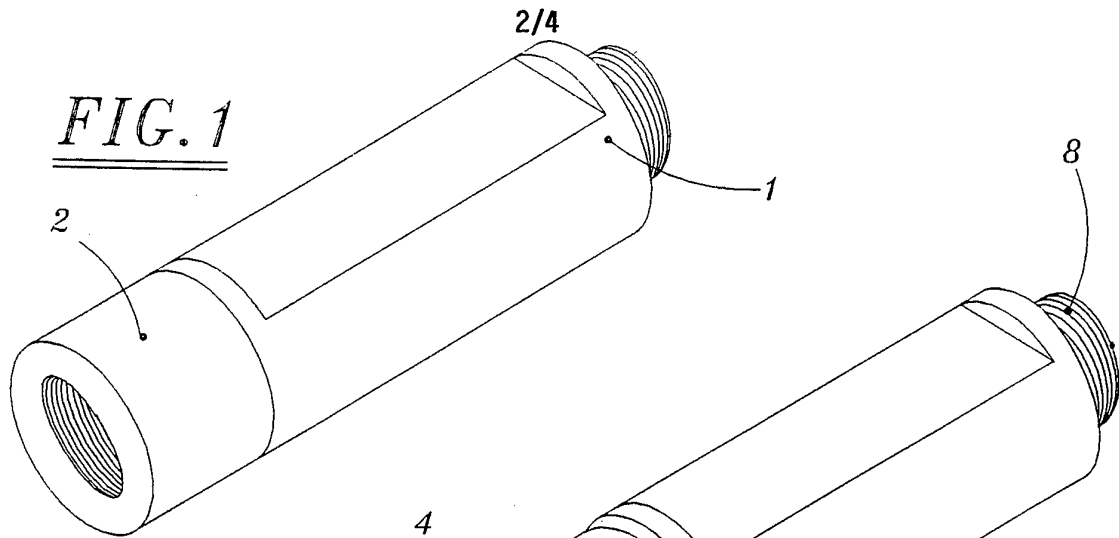

FIG. 8

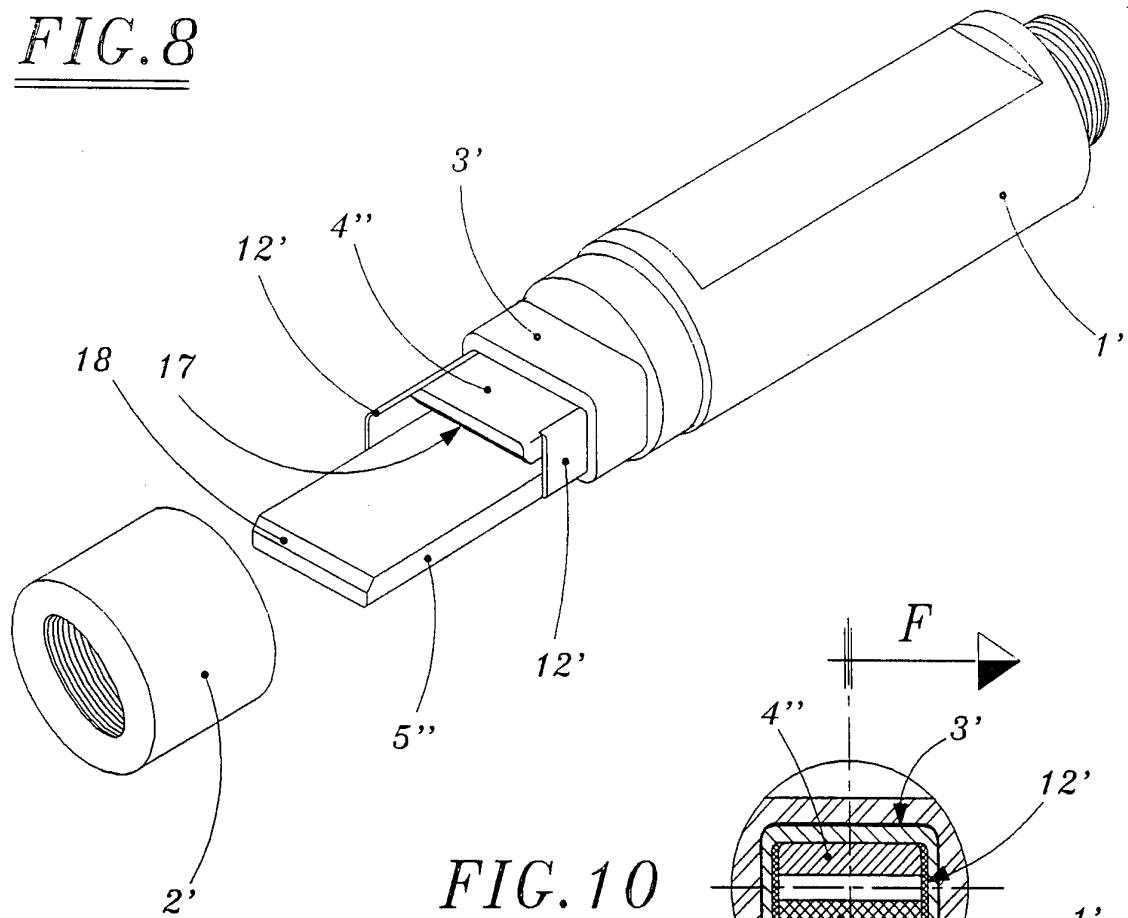

FIG. 10

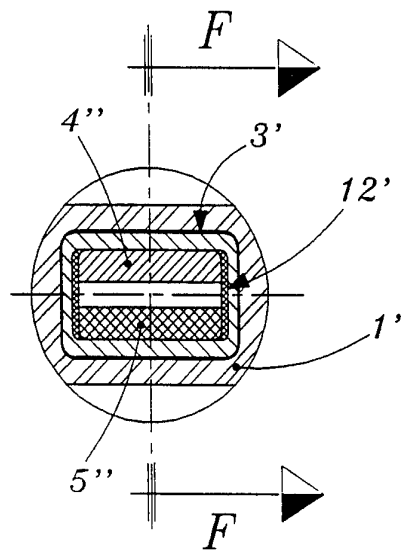

FIG. 9

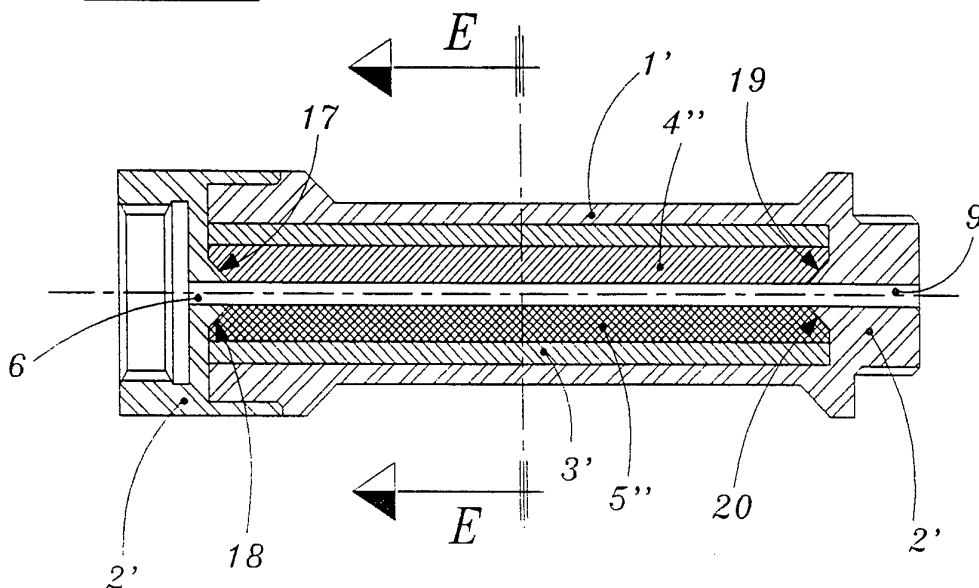

FIG. 14

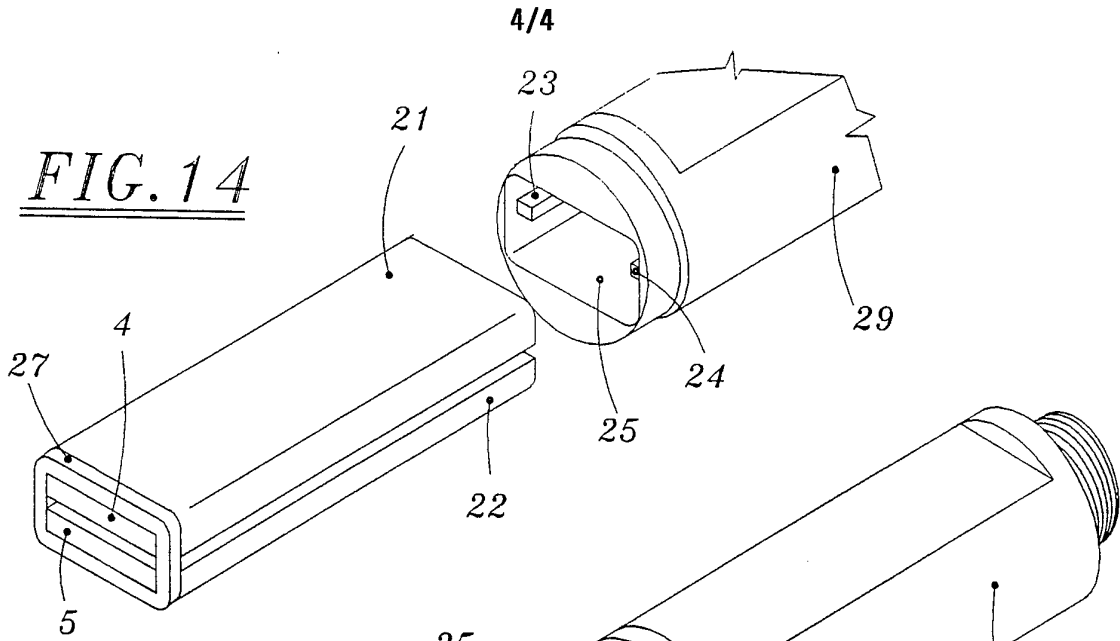

FIG. 11

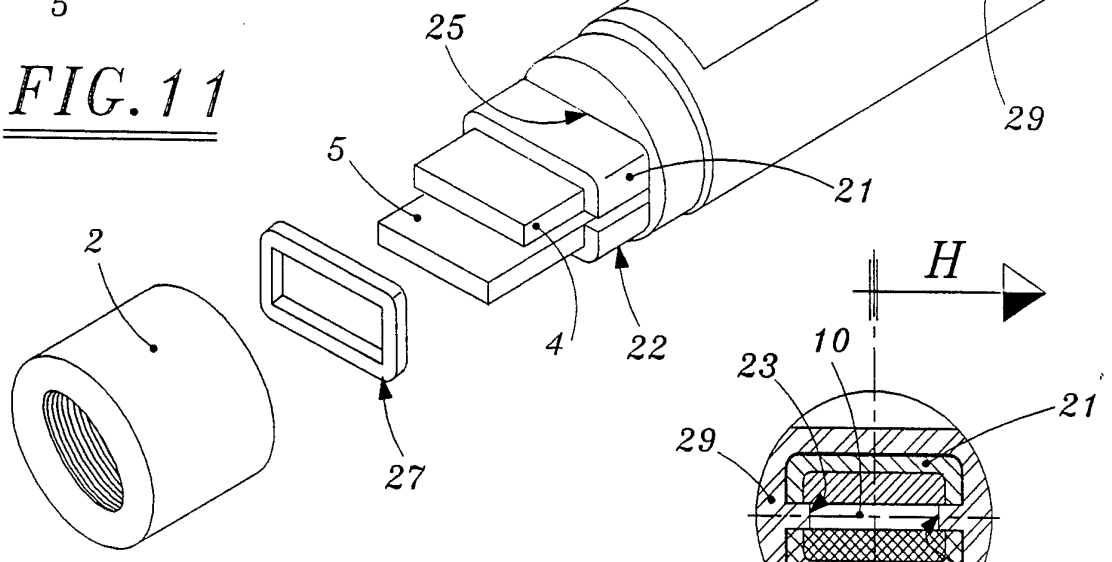

FIG. 13

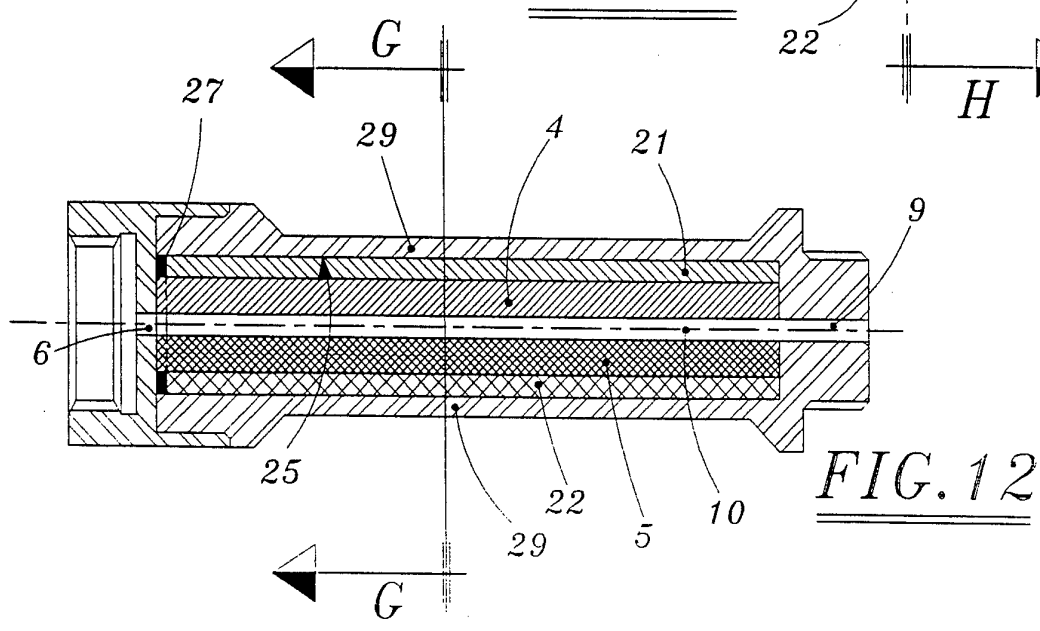
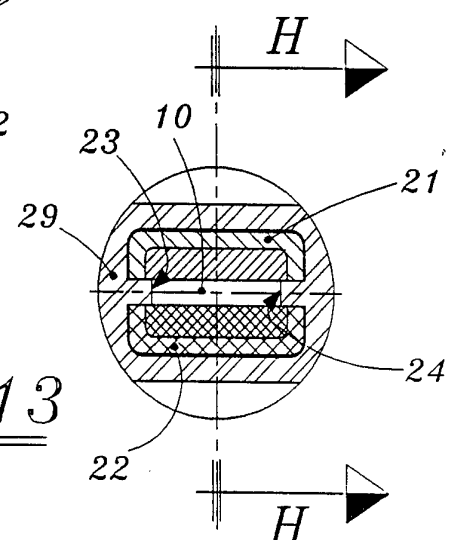

FIG. 12

INTERNATIONAL SEARCH REPORT

International Application No

PCT/IT 93/00088

I. CLASSIFICATION OF SUBJECT MATTER (if several classification symbols apply, indicate all) ⁴				
According to International Patent Classification (IPC) or to both National Classification and IPC				
IPC ⁵ : C 02 F 1/48, C 02 F 5/00				
II. FIELDS SEARCHED				
Minimum Documentation Searched ⁷				
Classification System	Classification Symbols			
IPC ⁵	C 02 F, B 01 J			
Documentation Searched other than Minimum Documentation to the Extent that such Documents are Included in the Fields Searched ⁸				
III. DOCUMENTS CONSIDERED TO BE RELEVANT ⁹				
Category ⁹	Citation of Document, ¹¹ with Indication, where appropriate, of the relevant passages ¹²	Relevant to Claim No. ¹³		
A	FR, A1, 2 611 691 (SCHIRMANN FRANCIS) 09 September 1988 (09.09.88), the whole document. ---	1, 3, 10		
A	WO, A1, 90/01 018 (LIFF INDUSTRIES) 08 February 1990 (08.02.90), fig. 1,3,5; page 3, line 8 - page 5. ----	1, 3, 8		
<table style="width: 100%; border: none;"> <tr> <td style="width: 50%; vertical-align: top; padding: 5px;"> ¹⁴ Special categories of cited documents: ¹⁴ "A" document defining the general state of the art which is not considered to be of particular relevance "E" earlier document but published on or after the International filing date "L" document which may throw doubts on priority claim(s) or which is cited to establish the publication date of another citation or other special reason (as specified) "O" document referring to an oral disclosure, use, exhibition or other means "P" document published prior to the international filing date but later than the priority date claimed </td> <td style="width: 50%; vertical-align: top; padding: 5px;"> "T" later document published after the international filing date or priority date and not in conflict with the application but cited to understand the principle or theory underlying the invention "X" document of particular relevance; the claimed invention cannot be considered novel or cannot be considered to involve an inventive step "Y" document of particular relevance; the claimed invention cannot be considered to involve an inventive step when the document is combined with one or more other such documents, such combination being obvious to a person skilled in the art. "Z" document member of the same patent family </td> </tr> </table>			¹⁴ Special categories of cited documents: ¹⁴ "A" document defining the general state of the art which is not considered to be of particular relevance "E" earlier document but published on or after the International filing date "L" document which may throw doubts on priority claim(s) or which is cited to establish the publication date of another citation or other special reason (as specified) "O" document referring to an oral disclosure, use, exhibition or other means "P" document published prior to the international filing date but later than the priority date claimed	"T" later document published after the international filing date or priority date and not in conflict with the application but cited to understand the principle or theory underlying the invention "X" document of particular relevance; the claimed invention cannot be considered novel or cannot be considered to involve an inventive step "Y" document of particular relevance; the claimed invention cannot be considered to involve an inventive step when the document is combined with one or more other such documents, such combination being obvious to a person skilled in the art. "Z" document member of the same patent family
¹⁴ Special categories of cited documents: ¹⁴ "A" document defining the general state of the art which is not considered to be of particular relevance "E" earlier document but published on or after the International filing date "L" document which may throw doubts on priority claim(s) or which is cited to establish the publication date of another citation or other special reason (as specified) "O" document referring to an oral disclosure, use, exhibition or other means "P" document published prior to the international filing date but later than the priority date claimed	"T" later document published after the international filing date or priority date and not in conflict with the application but cited to understand the principle or theory underlying the invention "X" document of particular relevance; the claimed invention cannot be considered novel or cannot be considered to involve an inventive step "Y" document of particular relevance; the claimed invention cannot be considered to involve an inventive step when the document is combined with one or more other such documents, such combination being obvious to a person skilled in the art. "Z" document member of the same patent family			
IV. CERTIFICATION				
Date of the Actual Completion of the International Search <p style="text-align: center;">23 November 1993</p>		Date of Mailing of this International Search Report <p style="text-align: center;">27. 12. 93</p>		
International Searching Authority <p style="text-align: center;">EUROPEAN PATENT OFFICE</p>		Signature of Authorized Officer <p style="text-align: center;">WILFLINGER e.h.</p>		

ANHANG

zum internationalen Recherchenbericht über die internationale Patentanmeldung Nr.

ANNEX

to the International Search Report to the International Patent Application No.

ANNEXE

au rapport de recherche international relatif à la demande de brevet international n°

PCT/IT 93/00088 SAE 78797

In diesem Anhang sind die Mitglieder der Patentfamilien der im obengenannten internationalen Recherchenbericht angeführten Patentedokumente angegeben. Diese Angaben dienen nur zur Unterrichtung und erfolgen ohne Gewähr.

This Annex lists the patent family members relating to the patent documents cited in the above-mentioned international search report. The Office is in no way liable for these particulars which are given merely for the purpose of information.

La présente annexe indique les membres de la famille de brevets relatifs aux documents de brevets cités dans le rapport de recherche international visée ci-dessus. Les renseignements fournis sont donnés à titre indicatif et n'engagent pas la responsabilité de l'Office.

Im Recherchenbericht angeführtes Patentedokument Patent document cited in search report Document de brevet cité dans le rapport de recherche	Datum der Veröffentlichung Publication date Date de publication	Mitglied(er) der Patentfamilie Patent family member(s) Membre(s) de la famille de brevets	Datum der Veröffentlichung Publication date Date de publication
FR A1 2611691	09-09-88	FR B1 2611691	12-07-91
WD A1 9001018	08-02-90	AU A1 40439/89	19-02-90
		EP A1 380644	08-08-90
		FI A0 901533	27-03-90
		GB A0 8817899	01-09-88
		GB A0 8917180	13-09-89
		GB A1 2221173	31-01-90
		GB B2 2221173	07-04-93