

E. G. WARD.

Metallic Burr.

No. 1,988.

Patented Feb. 20, 1841.

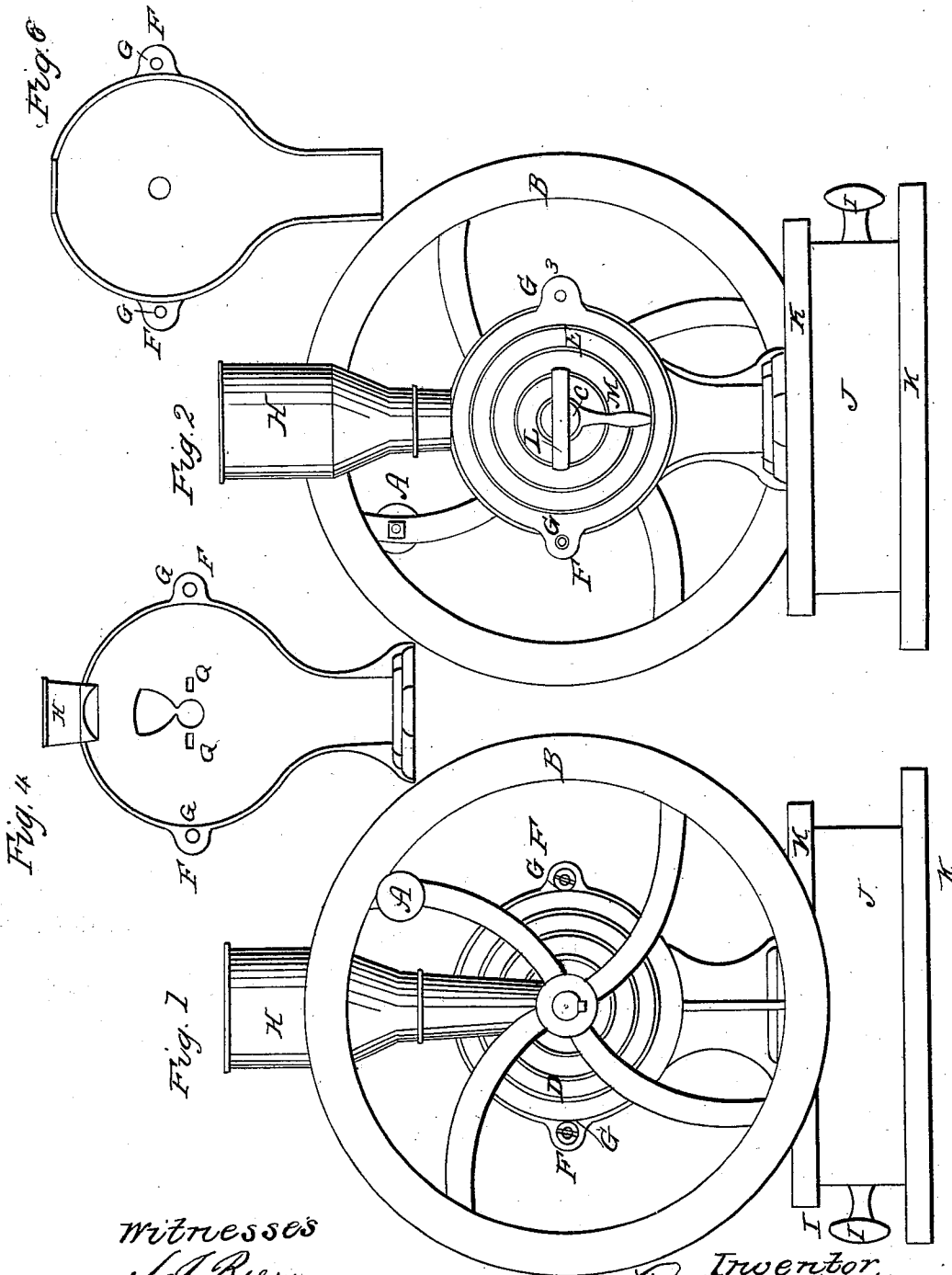

Witnesses
J. S. Burr
Peter Henry Meyer

Inventor
E. G. Ward

E. G. WARD.
Metallic Burr.

No. 1,988.

Patented Feb. 20, 1841.

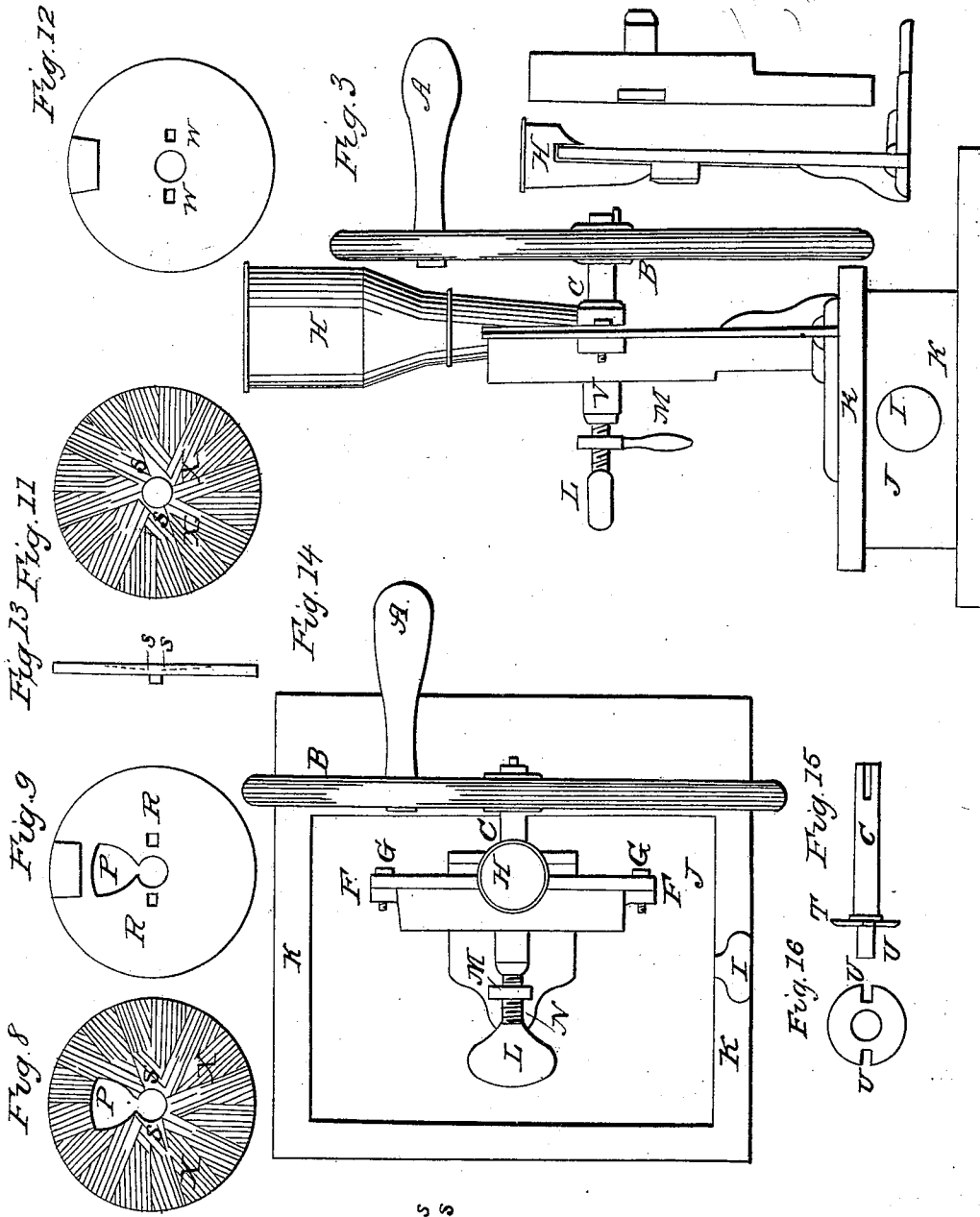

Witnesses
J. S. Parry
Peter Henry Dreyer

Inventor
Ezekiel Ward

UNITED STATES PATENT OFFICE.

EZEKIEL G. WARD, OF NEW YORK, N. Y.

MILL FOR GRINDING GRAIN.

Specification of Letters Patent No. 1,988, dated February 20, 1841.

To all whom it may concern:

Be it known that I, EZEKIEL G. WARD, of the city, county, and State of New York, have invented a new and useful Improvement in Mills; and I do hereby declare that the following is a full and exact description thereof.

This invention is called the Graham mill.

The nature of it consists in cast iron grinders or indented plates one of which is stationary while the other turns and grinds the grain which falls into the grinders through a core print connected with a hopper above, and when ground falls into a box placed beneath the machine to receive the flour.

To enable others to make and use my invention I proceed to describe its construction and operation—reference being had to the drawings hereunto annexed and forming part of this specification.

This mill is worked by the shaft (C), to which is attached a flywheel (B), with a handle, (A). To the inner end of the shaft is permanently secured the innermost or back grinder, (Figure 11,) the front or outside grinder being stationary and attached to the front case or covering (D,) (which front case is also represented by Fig. 4). These grinders are inclosed within hollow, concave cases or covering (Figs. 4 and 6; letters, D and E,) which cases are held together by screws (G G) through ears, (F, F). The cases are concave upon their inner faces to admit the interior machinery and have upon either side ears or extensions with holes to insert screws for the purpose of confining them together.

The front case (Fig. 4,) (D,) has a round hole through its center and a core print or another hole or particular form directly above the shaft hole, through which core print the grain passes from the hopper (H,) into or between the grinders. Upon either side of the shaft hole and on a line with the center of the ears, are two small steps or prominences (Q, Q,) which fit into corresponding mortises (R, R,) in the back of the front grinder, and by which this grinder is held firm and immovable to receive the action of its fellow which latter revolves (as hereafter described) with the shaft. Both cases are contracted though still hollow below the grinders to permit the passage of the grain when ground into the box (J,) in the base (K,) of the mill. The back case

(Fig. 6,) (E,) is made similar to the front case except that it has neither steps nor core print, but simply a hole through the center for the inner end of the shaft, and a hub or extension back of this hole to receive the thumb or regulating screw (N,) hereafter described.

The front grinder (Fig. 8) has a core print similar to the one in the front case, through which the grain passes into the grinders. The face of each grinder is covered with lands or furrows and is concave, so that the grain is coarsest at the shaft and become finer as it approaches the edges or peripheries of the grinders. Immediately next to the shaft are two large teeth or crackers (S, S,) to break the grain as it enters the grinders and before it is delivered to the surrounding lands. The back grinder, (Fig. 11), is similar to the front one except that it has no core print. This back grinder is attached permanently to the shaft by a suitable contrivance which will be described hereafter, and revolves with its shaft when the latter is put in motion by the flywheel and handle already mentioned.

The whole machine, thus far described rests upon a square frame work forming a base (K, K,) in which is a drawer (J,) that catches the flour as it falls from the grinders. This box has a small handle (I,) by which it is shoved in or drawn out as required.

Around the shaft (see Figs. 15 and 16,) and near its inner extremity and directly behind the back grinder is a raised flange (T,) containing two notches (U, U,) to receive the steps of the back grinder, and by which this grinder is held permanent and secure upon the shaft without bolts or screws.

There is a screw (N,) at the back of the mill working into the hub (V.) The inner end of this screw touches full upon the inner end of the shaft and regulates the distance between the grinders for the purpose of making the flour coarse or fine as required. When this screw is turned forward it presses the shaft out and of course brings the face of the back grinder which is permanent upon the shaft nearer to the face of the front grinder, and the nearer the two faces of the two grinders approaches the finer is the flour produced. The handle nut (M,) is placed upon the screw (N) to hold it at any required distance.

The hopper (H) is placed above the mill and the bottom of it opens into the core prints of the front case and front grinder, to admit the passage of the grain between the grinders.

Operation.—By turning the fly wheel the shaft and the back grinder revolves rapidly. The grain falls from the hopper through the core prints between the grinders. The front grinder remains stationary. The crackers break the grain, and it is then ground finer and finer by the lands, until it reaches the extremities of the grinders and falls into the box below.

Description of the drawings.—Fig. 1 is a front view of the mill. Fig. 2 is a back view of the same. Fig. 3 is an end view of the same. Fig. 4 is a sectional view of the front case or cover inclosing the grinders. Fig. 5 is an end view of the front case. Fig. 6 is a sectional view of the back case. Fig. 7 is an end view of the back case. Fig. 8 represents the front grinder with its lands, core print and crackers. Fig. 9 represents the back of the front grinder with its steps and core prints. Fig. 10 is an end view of the front grinder, its concavity being marked by the small dots, and the positions of the crackers shown by the letters, S, S. Fig. 11 represents the face of the back grinder with its lands and crackers. Fig. 12 represents the back of the back grinder with its steps. Fig. 13 is an end view of the back grinder its concavity being marked by the small dots, and the positions of the crackers shown by the letters S, S. Fig. 14 is a bird eye view of the whole mill. Fig. 15 is a view of the main shaft with its flange and notches. Fig. 16 is a view of the flange with its notches.

A, the handle by which the fly wheel is turned; B, the fly wheel; C, the shaft; D, the front case; E, the back case; F, the ears;

G, G, the screws of the ears; H, the hopper; I, the drawer handle; J, the drawer; K, the frame base of the mill; L, the handle of the thumb screw; M, the handle nut upon the thumb screw; N, the thumb screw; O, the core print in the front case; P, the core print in the front grinder; Q, Q, the steps of the front case; R, R, the steps of the front grinder; S, S, the crackers in the grinders; T, the flange of the shaft; U, U, the notches of the flange to receive the steps of the back grinder; V, the hub to receive the thumb screw; W, W, the steps of the back grinder; X, X, the lands of the grinders.

I am aware that mills have been made with the grinders revolving vertically, and that the grinders of mills have been made so that they could be removed from the shaft, and these I do not therefore claim as my invention; but

What I do claim as my invention and desire to secure by Letters Patent is—

The manner in which the grinders are connected with the case and shaft so that they can be removed at pleasure and without injury to any part of the mill; that is to say, I claim connecting the front grinder with the case by means of the steps fitting into notches in the mill case, in combination with the method of attaching the back grinder to the shaft by means of the flange on the shaft having notches into which fit steps projecting from the back of the grinder, the shaft passing through the two grinders by which they are centered, and the grinding being regulated by pressing the flange against the back of the back grinder, all as herein described.

EZEKIEL G. WARD.

Witnesses:

S. I. BURR,
ISAAC SCOTT.