

No. 676,599.

Patented June 18, 1901.

H. A. BERGOM.
FENCE POST PULLER.

(Application filed Mar. 21, 1901.)

(No Model.)

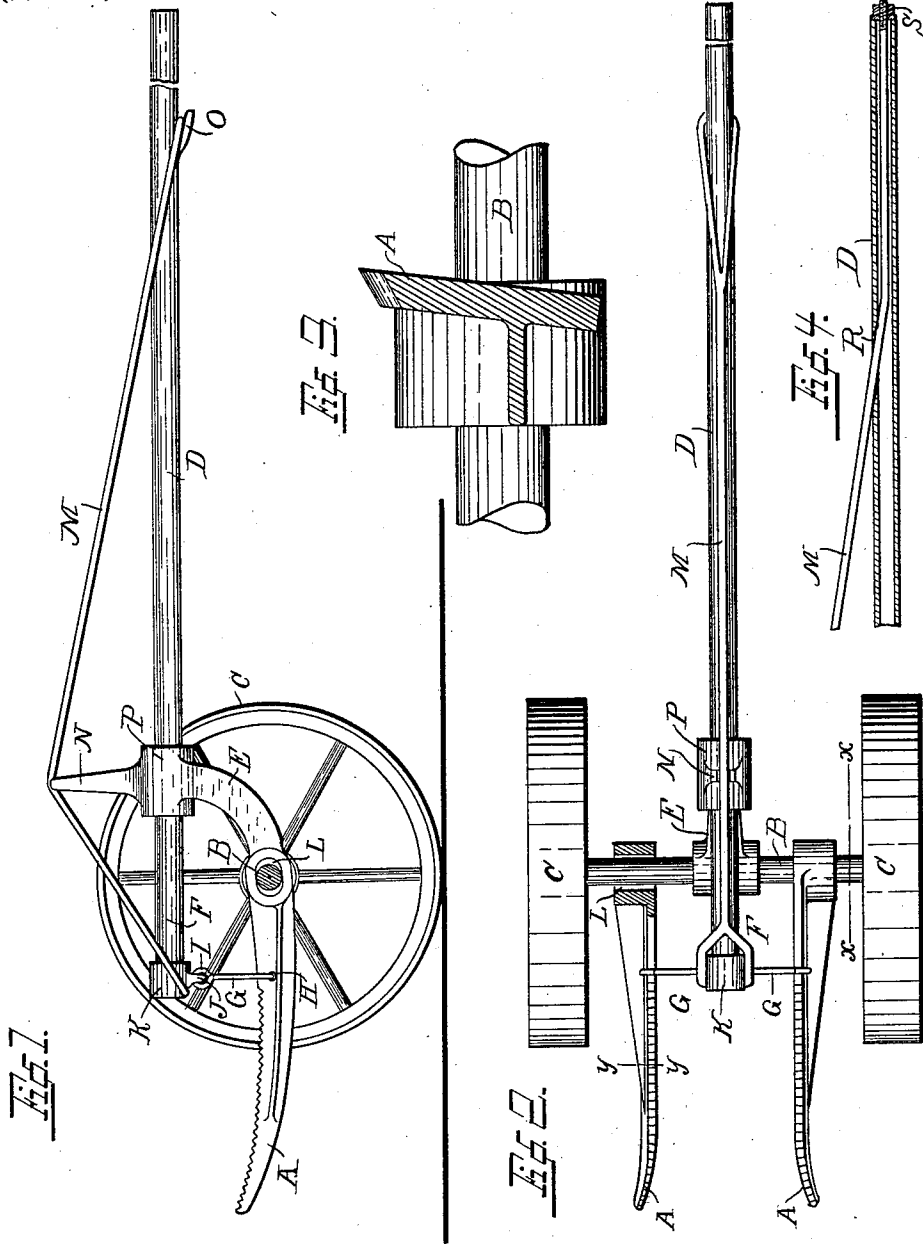

Witnesses:
F. A. ...
J. ...

Inventor
H. A. Bergom
Erwin & Whelen
 Attorneys

UNITED STATES PATENT OFFICE.

HANS A. BERGOM, OF STOUGHTON, WISCONSIN.

FENCE-POST PULLER.

SPECIFICATION forming part of Letters Patent No. 676,599, dated June 18, 1901.

Application filed March 21, 1901. Serial No. 52,138. (No model.)

To all whom it may concern:

Be it known that I, HANS A. BERGOM, a citizen of the United States, residing at Stoughton, county of Dane, and State of Wisconsin, have invented new and useful Improvements in Fence-Post Pullers, of which the following is a specification.

My invention relates to improvements in devices for pulling fence-posts from the ground.

10 The object of my invention is to provide a portable device which when it is desired to move a fence may be readily and conveniently transported from one of the posts of the fence to another, which device is provided with clamping-arms, which arms, when brought upon the two opposite sides of a fence-post, will automatically engage the surface of the same, when by downward pressure upon an operating-lever the post will be quickly and easily lifted and drawn from the ground.

The construction of my invention is further explained by reference to the accompanying drawings, in which—

25 Figure 1 represents a side view drawn on line *xx* of Fig. 2. Fig. 2 is a top view showing a portion of one of the clamping-arms in section. Fig. 3 is a detail drawn on line *yy* of Fig. 2. Fig. 4 represents a preferred form of the device for attaching the brace-rod to the operating-lever.

Like parts are identified by the same reference-letters throughout the several views.

35 A A are the clamping-arms, which are adapted to engage the two opposite sides of the post to be pulled. The clamping-arms A are pivotally supported at one end upon the axle or shaft B, which axle is in turn supported at its respective ends by the wheels 40 C C. The upper edges of the clamping-arms A are inclined inwardly, as shown in Fig. 3, and are preferably serrated, as indicated in Fig. 2, whereby they are adapted to engage more securely in the sides of the post.

45 D is an operating-lever which is supported from the shaft B by the bracket E. The bracket E is rigidly affixed to the center of the axle B, which axle serves as a fulcrum to the operating-lever. The clamping-arms A 50 are connected with the short arm F of said operating-lever by the links G G, which links are connected at their lower ends to said

clamping-arms in apertures II and are connected at their upper ends with the short arm F of said lever by the loop I, which loop 55 passes through an aperture J, formed in the lower side of the sleeve K, the sleeve K being rigidly secured, as shown, to the end of said arm F. To provide for the required lateral movement of said clamping-arms A as 60 they are drawn together against the surfaces of posts of different diameters, they are respectively provided with elongated apertures L, which surround the axle B, which apertures L permit the free ends of said clamping- 65 arms to move toward and from each other.

M is a brace-rod for strengthening and supporting the operating-lever D. One end of the brace-rod M is secured to the free end of the short arm of said lever when it passes 70 over the truss or bearing N rearwardly to near the end of the lever D, where it is secured to said lever by the pin or bracket O. For convenience of construction the truss N is cast integral with the bracket E, while said 75 bracket is also provided with a collar P for the reception of said operating-lever, which is rigidly secured therein, as shown.

In the device shown in Fig. 4 is illustrated the preferred form of construction by which 80 the brace-rod M passes through an aperture R in said lever and is extended through the center of said operating-lever to its end, when it is secured at such point by the nut S, which is threaded to the end of said rod, whereby it 85 is obvious that should said rod M become slack such slack may be taken up by turning down the nut S against the end of said operating-lever.

It will of course be understood that while 90 the wheels C C are preferred runners or other supports may be substituted for supporting the axle or shaft B, which serves as a fulcrum for the operating-lever. It will also be understood that by thus interposing the operat- 95 ing-lever D centrally between the clamping-arms A A the free ends of said clamping-arms will be drawn together by the upward movement of the short arm of said operating-lever.

Having thus described my invention, what 100 I claim as new, and desire to secure by Letters Patent, is—

1. In a post-puller, the combination of a pivotal shaft or axle; means for supporting

said shaft or axle at its respective ends; two parallel clamping-arms respectively supported at one end from said pivotal shaft; an operating-lever centrally supported from said pivotal shaft between said clamping-arms; and flexible connections communicating between said clamping-arms and the short arm of said operating-lever, as set forth.

2. In a post-puller, the combination of a pivotal shaft or axle; means for supporting said shaft or axle at its respective ends; two parallel clamping-arms respectively supported at one end from said pivotal shaft; an operating-lever centrally supported from said pivotal shaft between said clamping-arms; a truss or standard projecting upwardly from the upper side of said operating-lever; a strengthening-rod communicating from one end of said lever to the other, over said truss or standard; and flexible connections communicating between said clamping-arms and the short arm of said operating-lever, as set forth.

3. In a post-puller, the combination of a pivotal shaft or axle; means for supporting said shaft or axle at its respective ends; two parallel clamping-arms respectively supported at one end from said pivotal shaft; an operating-lever centrally supported from said pivotal shaft between said clamping-arms; a truss or standard projecting upwardly from the upper side of said operating-lever; a

strengthening-rod communicating from one end of said lever to the other, over said truss or standard; said strengthening-rod having supporting-bearings at one end, centrally in the long arm of said operating-lever; a nut having threaded bearings on the end of said strengthening-rod, and adapted, by turning, to take up the slack of said rod; and flexible connections communicating between said clamping-arms and the short arm of said operating-lever, as set forth.

4. In a post-puller, the combination of a pivotal shaft or axle; supporting-wheels connected with the respective ends of said axle; two parallel clamping-arms, provided with serrated edges, respectively supported at one end from said pivotal shaft; an operating-lever centrally supported from said pivotal shaft between said clamping-arms; a truss or standard projecting upwardly from the upper side of said operating-lever; a strengthening-rod communicating from one end of said lever to the other, over said truss or standard; and flexible connections communicating between said clamping-arms and the short arm of said operating-lever, as set forth.

In testimony whereof I affix my signature in the presence of two witnesses.

HANS A. BERGOM.

Witnesses:

ERLING K. LOVERUD,
J. M. CLANCEY.