

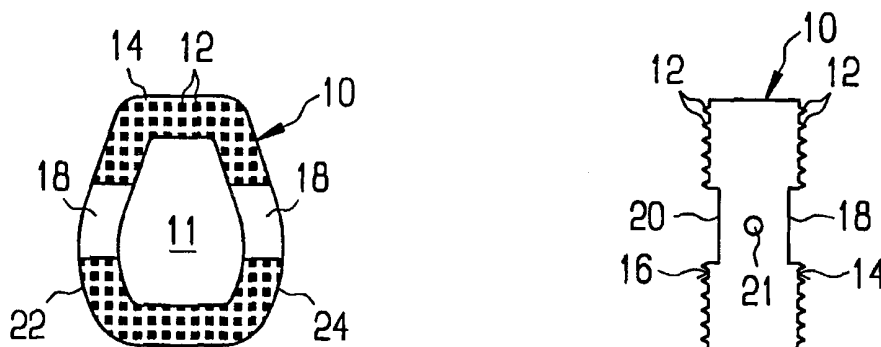

## INTERNATIONAL APPLICATION PUBLISHED UNDER THE PATENT COOPERATION TREATY (PCT)

<p>(51) International Patent Classification<sup>6</sup> : <b>A61F 2/44</b></p>	<p><b>A2</b></p>	<p>(11) International Publication Number: <b>WO 99/38461</b></p> <p>(43) International Publication Date: 5 August 1999 (05.08.99)</p>
<p>(21) International Application Number: PCT/EP99/00433</p> <p>(22) International Filing Date: 22 January 1999 (22.01.99)</p> <p>(30) Priority Data: 60/073,271 30 January 1998 (30.01.98) US 60/095,425 5 August 1998 (05.08.98) US</p> <p>(71) Applicant (for all designated States except CA): SYNTHES AG CHUR [CH/CH]; Grabenstrasse 15, CH-7002 Chur (CH).</p> <p>(71) Applicant (for CA only): SYNTHES (U.S.A.) [US/US]; 1690 Russell Road, P.O. Box 1766, Paoli, PA 19301-1222 (US).</p> <p>(72) Inventors: PAUL, David, C.; 1513 Valley Road, Drexel Hill, PA 19026 (US). EMCH, Hansjuerg, W.; 1527 Spruce Street, Philadelphia, PA 19102 (US). SCHENK, Beat; 59 Cobblestone Drive, Paoli, PA 19301 (US). CARVER, Jeffrey, L.; 1011 Welsh Ayres Way, Downingtown, PA 19335 (US). BAKER, Kelly, J.; 1878 Shadyside Road, Coatesville, PA 19320 (US).</p> <p>(74) Agent: LUSUARDI, Werther; Dr. Lusuardi AG, Kreuzbühlstrasse 8, CH-8008 Zürich (CH).</p>		<p>(81) Designated States: CA, JP, European patent (AT, BE, CH, CY, DE, DK, ES, FI, FR, GB, GR, IE, IT, LU, MC, NL, PT, SE).</p> <p><b>Published</b> <i>Without international search report and to be republished upon receipt of that report.</i></p>

(54) Title: ALLOGENIC INTERVERTEBRAL IMPLANT



## (57) Abstract

An allogenic intervertebral implant (10) for fusing vertebrae is disclosed. The implant (10) is an annular plug conforming in size and shape with end plates of vertebrae. The implant has either an exterior surface identical to that of the harvest bone or an exterior surface machined to have a uniform shape such as an oval or a rectangle. The top and bottom surfaces (14, 16) of the implant (10) have a plurality of teeth (12) to resist expulsion and provide initial stability. The top and bottom surfaces (14, 16) can be either flat planar surfaces or curved surfaces. Preferably, the anterior height of the implant is greater than the posterior height so that the implant is wedge-shaped profile to help restore disc height and the natural curvature of the spine. In one embodiment, the top and bottom surfaces each have a channel oriented in the anterior, lateral, or antero-lateral direction for receiving a surgical instrument. The implant can also have a hole for attachment of an inserter. Although the interior space formed by the annular plug can be the natural shape defined by the medullary canal, the medullary canal walls can be machined so that the implant has a uniform interior space.

**FOR THE PURPOSES OF INFORMATION ONLY**

Codes used to identify States party to the PCT on the front pages of pamphlets publishing international applications under the PCT.

<b>AL</b>	Albania	<b>ES</b>	Spain	<b>LS</b>	Lesotho	<b>SI</b>	Slovenia
<b>AM</b>	Armenia	<b>FI</b>	Finland	<b>LT</b>	Lithuania	<b>SK</b>	Slovakia
<b>AT</b>	Austria	<b>FR</b>	France	<b>LU</b>	Luxembourg	<b>SN</b>	Senegal
<b>AU</b>	Australia	<b>GA</b>	Gabon	<b>LV</b>	Latvia	<b>SZ</b>	Swaziland
<b>AZ</b>	Azerbaijan	<b>GB</b>	United Kingdom	<b>MC</b>	Monaco	<b>TD</b>	Chad
<b>BA</b>	Bosnia and Herzegovina	<b>GE</b>	Georgia	<b>MD</b>	Republic of Moldova	<b>TG</b>	Togo
<b>BB</b>	Barbados	<b>GH</b>	Ghana	<b>MG</b>	Madagascar	<b>TJ</b>	Tajikistan
<b>BE</b>	Belgium	<b>GN</b>	Guinea	<b>MK</b>	The former Yugoslav Republic of Macedonia	<b>TM</b>	Turkmenistan
<b>BF</b>	Burkina Faso	<b>GR</b>	Greece			<b>TR</b>	Turkey
<b>BG</b>	Bulgaria	<b>HU</b>	Hungary	<b>ML</b>	Mali	<b>TT</b>	Trinidad and Tobago
<b>BJ</b>	Benin	<b>IE</b>	Ireland	<b>MN</b>	Mongolia	<b>UA</b>	Ukraine
<b>BR</b>	Brazil	<b>IL</b>	Israel	<b>MR</b>	Mauritania	<b>UG</b>	Uganda
<b>BY</b>	Belarus	<b>IS</b>	Iceland	<b>MW</b>	Malawi	<b>US</b>	United States of America
<b>CA</b>	Canada	<b>IT</b>	Italy	<b>MX</b>	Mexico	<b>UZ</b>	Uzbekistan
<b>CF</b>	Central African Republic	<b>JP</b>	Japan	<b>NE</b>	Niger	<b>VN</b>	Viet Nam
<b>CG</b>	Congo	<b>KE</b>	Kenya	<b>NL</b>	Netherlands	<b>YU</b>	Yugoslavia
<b>CH</b>	Switzerland	<b>KG</b>	Kyrgyzstan	<b>NO</b>	Norway	<b>ZW</b>	Zimbabwe
<b>CI</b>	Côte d'Ivoire	<b>KP</b>	Democratic People's Republic of Korea	<b>NZ</b>	New Zealand		
<b>CM</b>	Cameroon			<b>PL</b>	Poland		
<b>CN</b>	China	<b>KR</b>	Republic of Korea	<b>PT</b>	Portugal		
<b>CU</b>	Cuba	<b>KZ</b>	Kazakistan	<b>RO</b>	Romania		
<b>CZ</b>	Czech Republic	<b>LC</b>	Saint Lucia	<b>RU</b>	Russian Federation		
<b>DE</b>	Germany	<b>LI</b>	Liechtenstein	<b>SD</b>	Sudan		
<b>DK</b>	Denmark	<b>LK</b>	Sri Lanka	<b>SE</b>	Sweden		
<b>EE</b>	Estonia	<b>LR</b>	Liberia	<b>SG</b>	Singapore		

## ALLOGENIC INTERVERTEBRAL IMPLANT

This invention concerns a device in accordance with the pre-characterising portion of Claim 1. More particularly, it refers to an allogenic intervertebral implant for use in the treatment of back pain.

A number of medical conditions such as compression of spinal cord nerve roots, degenerative disc disease, and trauma can cause severe back pain. Intervertebral fusion is a surgical method of alleviating back pain. In intervertebral fusion, two adjacent vertebral bodies are fused together by removing the affected intervertebral disc and inserting an implant that would allow for bone to grow between the two vertebral bodies to bridge the gap left by the disc removal.

A number of different implants and implant materials have been used for fusion with varying success. Current implants used include titanium cages and allografts. Titanium cages suffer from the disadvantage of requiring drilling and tapping of the vertebral endplates for insertion. In addition, the incidence of subsidence in long term use is not known. Due to MRI

incompatibility of titanium, determining fusion is problematic. Finally, restoration of lordosis, i.e., the natural curvature of the cervical and lumbar spine is very difficult when a titanium cage is used.

Allografts are sections of bone taken from the diaphysis of a long bone, such as the radius, ulna, fibula, humerus, tibia, or femur of a donor. A cross section of the bone is taken and processed using known techniques to preserve the allograft until implantation and reduce the risk of an adverse immunological response when implanted. For example, U.S. Patent No. 4,678,470 discloses a method for processing a bone grafting material which uses glutaraldehyde tanning to produce a non-antigenic, biocompatible material. Allografts have mechanical properties which are similar to the mechanical properties of vertebrae even after processing. This prevents stress shielding that occurs with metallic implants. They are also MRI compatible so that fusion can be more accurately ascertained and promote the formation of bone, i.e., osteoconductive. Although the osteoconductive nature of the allograft provides a biological interlocking between the allograft and the vertebrae for long term mechanical strength, initial and short term mechanical strength of the interface between the allograft and the vertebrae are lacking such that there is a possibility of the allograft being expelled after implantation.

U.S. Patent No. 5,728,159 discloses an allograft having grooves on end faces in an attempt to try to promote stability, but there are more effective ways for resisting expulsion.

For example, WO 98/17209, published April 30, 1998, is directed to a spinal spacer and has one embodiment which is an allograft cortical ring having teeth on superior and/or inferior surfaces. These teeth provide the initial, secure interlocking with the vertebrae.

Most allografts are simply sections of bone which, although cut to the approximate height of the disc being replaced, have not been sized and/or machined on the exterior surface to have a uniform shape. As a result, the fusion of the vertebral bodies does not occur in optimal anatomic position in a consistent manner along the surface of the endplates. While a surgeon may do some minimal intraoperative shaping and sizing to customize the allograft for the patient's anatomy, significant shaping and sizing of the allograft is not possible due to the nature of the allograft. Even if extensive shaping and sizing were possible, a surgeon's ability to manually shape and size the allograft to the desired dimensions is severely limited.

As the discussion above illustrates, there is a need for an improved allogenic implant for fusing vertebrae and relieving back pain. The invention as claimed aims at solving the above described problems.

The present invention provides an allogenic intervertebral implant for use when surgical fusion of vertebral bodies is indicated as defined in Claim 1.

The annular plug of allogenic bone is dimensioned in such a way that it conforms in size and shape with end plates of adjacent vertebrae, i.e. a rounded or approximately circular form.

In a preferred embodiment the three-dimensional structure of the intervertebral implant includes a plurality of teeth. Preferably the three-dimensional structure has a minimum height of 0,5 mm and a maximum height of 1,5 mm relative to the top and bottom surfaces of the implant.

The teeth preferably have a pyramid shape or a saw-tooth shape. In one embodiment, the implant has an exterior surface machined to have a uniform shape, such as an oval or a rectangle. The interior space delineated by the annular plug also can have a machined wall to provide the implant with a uniform interior space. The interior space delineated by the annular plug can be filled with spongiosa, bone graft substitutes or artificial bone material.

The top and bottom surfaces may be flat planar surfaces or curved surfaces to mimic the topography of the end plates of the adjacent vertebrae. In a preferred embodiment, the anterior

height of the implant is greater than the posterior height of the implant so that the implant has a wedge-shaped profile to help restore disc height and the natural curvature of the spine.

In one embodiment, the implant has channels on the top and bottom surfaces for receiving a surgical tool, e.g. a distractor. These channels can run in the anterior, lateral, or antero-lateral direction to accommodate a variety of different tools used in surgical procedures. Finally, a threaded hole on the anterior, antero-lateral, or lateral side can be provided for receiving a threaded arm of an insertion tool.

The allogenic bone is preferably in the form of a cross section transverse to the longitudinal axis a human long bone, typically with a height of 5 to 8 mm. Preferably the allogenic bone has been process frozen or freeze dried. The allogenic bone may also be treated with an antiseptic solution.

In the drawings:

FIG. 1 is a top view of a first embodiment of the implant according to the present invention;

FIG. 2 is a front view of the implant of FIG. 1;

FIG. 3 is a top view of a second embodiment of the implant;

FIG. 4 is a side view of the implant of FIG. 1;

FIG. 5 is a side view of a third embodiment of the implant;

FIG. 6 is a close up of region A from FIG. 4 and FIG. 8;

FIG. 7 is a top view of a fourth embodiment of the implant according to the present invention;

FIG. 8 is a side view of the implant of FIG. 7;

FIG. 9 is a top view of a sixth embodiment of the implant; and

FIG. 10 shows an alternative tooth configuration.

FIG. 1 shows a top view of a first embodiment of an allogenic intervertebral implant 10 according to the present invention. Implant 10 is annular and conforms in size and shape with the end plates of the vertebrae between which implant 10 is to be implanted. Because implant 10 is annular, new bone can form in interior 11. Interior 11 can be filled with bone chips or any other osteoconductive material to promote the formation of bone. Although implant 10 will probably be predominantly used in the lumbar region of the spine, implant 10 can be configured for implantation in any region of the spine. Implant 10 has a plurality of teeth 12 on superior and inferior surfaces 14, 16 which provide a mechanical interlock between implant 10 and the end plates. These teeth 12 provide the mechanical interlock by



penetrating the end plates. The initial mechanical stability afforded by teeth 12 minimizes the risk of post-operative expulsion of implant 10. Preferably, teeth 12 are pyramid-shaped in which the angle formed from the tip to the base may be between about 45 and 75° and is preferably about 60°. The details of teeth 12 are best seen in FIG. 6. The teeth provide an enhanced interlock with the adjacent vertebrae compared to the use of channels, because the teeth impale the vertebrae surfaces. In comparison, channels impart grooves into the vertebrae surfaces and the implant can slide out along the direction of the channels or grooves. In an alternative embodiment, teeth 12 have a saw-tooth shape (FIG. 10).

As shown in FIG. 1 and FIG. 2, superior surface 14 has a channel 18 and inferior surface 16 has a channel 20 which is parallel to channel 18. Channels 18, 20 are sized to receive a surgical instrument such as an inserter and/or distractor. As the names imply, an inserter is a surgical instrument used to insert implant 10 and a distractor is a surgical instrument used to separate the adjacent vertebrae so that the surgeon has access to the intervertebral space. If the inserter has a threaded arm, implant 10 can be provided with optional threaded hole 21. In FIG. 1 and FIG. 2, channels 18 and 20 are oriented in the anterior/posterior direction. This orientation is useful if the surgeon prefers an anterior surgical approach.

FIG. 3 shows a second embodiment of an allogenic intervertebral implant 110 according to the present invention. In general, most of the structure of implant 110 (as well as the embodiments described below) is like or comparable to the structure of implant 10 and, accordingly the same reference numeral is used for like components and discussion of those like components is not believed necessary. As shown in FIG. 3, channels 18, 20 can run in the antero-lateral direction to facilitate use of implant 110 with an antero-lateral surgical approach. As another alternative embodiment, channels 18, 20 could run in the lateral direction for a lateral approach. Similarly, a threaded hole 21 optionally can be located on the lateral or antero-lateral side of implant 10.

In order to restore the natural curvature of the spine after the affected disc has been removed, implant 10 is provided with a wedge-shaped profile. As shown in FIG. 4, one way to achieve this wedge shape results from a gradual decrease in height from the anterior side 22 to the posterior side 24. In anatomical terms, the natural curvature of the lumbar spine is referred to as lordosis. When implant 10 is to be used in the lumbar region, angle  $\alpha$  should be approximately  $4,2^\circ$  so that the wedge shape is a lordotic shape which mimics the anatomy of the lumbar spine. Furthermore, when used in the lumbar region, the ratio of the height of anterior side 22 ( $h_1$ ) to the height of posterior side 24 ( $h_2$ ) should be approximately 1,1-2 with the length of implant 10 (l) being approximately 22 - 30 mm.

In FIG. 4, superior and inferior surfaces 14, 16 are flat planar surfaces so that if the surgeon prepares the endplates to be parallel surfaces with a burr, implant 10 fits tightly between the bone surfaces.

FIG. 5 illustrates that superior and inferior surfaces 14, 16 of a third embodiment of an allogenic intervertebral implant 210 can be curved surfaces and still retain the wedge-shaped profile. The curved surface of superior and inferior surfaces 14, 16 is a mirror-image of the topography of the vertebral end plates. Thus, the curved surfaces conform to the contours of the end plates.

FIG. 7 shows a top view of a fourth embodiment of an allogenic intervertebral implant 310 according to the present invention. Although implant 310 will probably be predominantly used in the cervical region of the spine, implant 310 can be configured for implantation in any region of the spine. Interior 11 can be defined by the natural shape of the medullary canal as was the case for implant 10, 110, 210. Alternatively, the medullary canal can be machined so that the wall that formed interior 11 are uniform in shape and texture.

As previously noted, teeth 12 are preferably pyramid-shaped in which the angle formed from the tip to the base is preferably about 60°. Pyramid-shaped teeth help prevent expulsion of the implant in all directions. The prevention of movement between

implant 310 and the vertebrae is particularly important when the surgeon removes all of the annulus fibrosis, as may be the case for cervical vertebrae.

Most allografts are processed and used without significant machining of the exterior surface. In other words, the allografts have substantially the shape of the bone from which the allograft was harvested. As shown in FIG. 7, an exterior surface 26 of implant 310 has been machined to have a uniform shape. The uniform shape promotes initial stability until biological fixation is achieved with bony fusion.

As shown in FIG. 7, the exterior surface 26 has an oval shape. The oval shape preferably is arranged to have lateral sides 28 along the smaller oval axis and anterior and posterior sides 22, 24 along the longer axis. In another embodiment of the invention shown in FIG. 9, the exterior surface 26 of implant 410 is rectangular in shape with lateral sides 28 shorter in length than anterior and posterior sides 22, 24. The oval and rectangle shape and size of implants 310, 410 can be made to closely match the shape and size of the affected vertebrae. Typically, lateral sides 28 and anterior and posterior sides 22, 24 would be approximately 8-18 mm in length.

In order to restore the intervertebral space to the proper size after the affected disc has been removed, implant 310 has a height,  $h$ , sized to match the height of the removed disc, as shown in FIG. 8. The matched height helps promote fusion by

providing direct contact between the bone and implant 310. Typically, h would be approximately 4-20 mm for cervical vertebrae. Implant 310 has a uniform height so that the profile of implant 310 is rectangular. Alternatively, as shown in FIG. 4 and FIG. 5, implant 310 can have a wedge shaped profile with either flat planar surfaces or curved surfaces.

It should be noted that implants 310, 410 can be configured so that h would be approximately 10-100 mm. These larger sizes could be used in corpectomy, a surgical procedure in which a section of several vertebrae is removed. Implants 310, 410 would be inserted in the space created by the removed section of bone. Due to the nature of corpectomy, an accurate preoperative determination of the size of the implant needed is not possible. Thus, implant 310, 410 can be cut to the proper size by the surgeon. In such cases, the implants 310, 410 would only have teeth on either superior surface 14 or inferior surface 16.

## CLAIMS

1. Intervertebral implant (10) comprising an annular plug of allogenic bone conforming in size and shape with end plates of vertebrae, wherein top and bottom surfaces (14,16) of the implant (10) include a three-dimensional structure (12) positioned thereon for interlocking with adjacent vertebrae.
2. Intervertebral implant (10) according to claim 1, wherein said three-dimensional structure (12) includes a plurality of teeth.
3. Intervertebral implant (10) according to claim 1 or 2, wherein said three-dimensional structure (12) has a minimum height of 0,5 mm relative to the top and bottom surfaces (14,16).
4. Intervertebral implant (10) according to one of the claims 1 to 3, wherein said three-dimensional structure (12) has a maximum height of 1,5 mm relative to the top and bottom surfaces (14,16).
5. Intervertebral implant (10) according to one of the claims 1 to 4, wherein said allogenic bone has been obtained from a human long bone, preferably from a femur, humerus, radius, ulna or fibula.
6. Intervertebral implant (10) according to claim 5, wherein said allogenic bone is a cross section transverse to the longitudinal axis of said long bone, preferably with a height of 5 to 8 mm.

7. Intervertebral implant (10) according to one of the claims 1 to 6, wherein said allogenic bone is treated with an antiseptic solution.
8. Intervertebral implant (10) according to one of the claims 1 to 7, wherein said allogenic bone has been process frozen or freeze dried.
9. Intervertebral implant (10) according to one of the claims 1 to 8, wherein the allogenic bone comprises glutaraldehyde.
10. Intervertebral implant (10) according to one of the claims 1 to 9, wherein the interior space delineated by the annular plug is filled with spongiosa, bone graft substitutes or artificial bone material.
11. Intervertebral implant (10) according to one of the claims 1 to 10, wherein the top and bottom (14,16) surfaces each have a channel (18,20) for receiving a surgical instrument.
12. Intervertebral implant (10) according to claim 11, wherein the channels (18,20) run in an anterior-posterior direction.
13. Intervertebral implant (10) according to claim 11, wherein the channels (18,20) run in an antero-lateral direction.
14. Intervertebral implant (10) according to claim 11, wherein the channels (18,20) run in a lateral direction.

15. Intervertebral implant (10) according to one of the claims 1 to 14, wherein the implant has a wedge-shaped profile to help restore disc height and spine curvature.

16. Intervertebral implant (10) according to claim 15, wherein said implant has an anterior height which is greater than a posterior height to produce the wedge-shaped profile.

17. Intervertebral implant (10) according to one of the claims 1 to 16, wherein the teeth (12) have a pyramidal shape.

18. Intervertebral implant (10) according to one of the claims 1 to 17, wherein at least one side of the implant (10) has at least one hole for attachment of an inserter.

19. Intervertebral implant (10) according to claim 18, wherein the at least one hole is threaded.

20. Intervertebral implant (10) according to claim 19, wherein the at least one hole is provided in an anterior, antero-lateral, or lateral side.

21. Intervertebral implant (10) according to one of the claims 1 to 20, wherein the top and bottom surfaces (14,16) are flat planar surfaces.



22. Intervertebral implant (10) according to one of the claims 1 to 20, wherein the top and bottom surfaces (14,16) are curved surfaces which are contoured to mimic the end plates of the adjacent vertebrae.

23. Intervertebral implant (10) according to one of the claims 1 to 22, wherein the exterior surface of said implant has a uniform shape.

24. Intervertebral implant (10) according to claim 23, wherein the exterior surface has an oval shape.

25. Intervertebral implant (10) according to claim 23, wherein the exterior surface has a rectangular shape.

26. Intervertebral implant (10) according to one of the claims 1 to 25, wherein the annular plug includes an interior surface of a machined wall.

27. Intervertebral implant (10) according to one of the claims 1 to 26, wherein, the teeth have a saw tooth shape.

FIG. 1

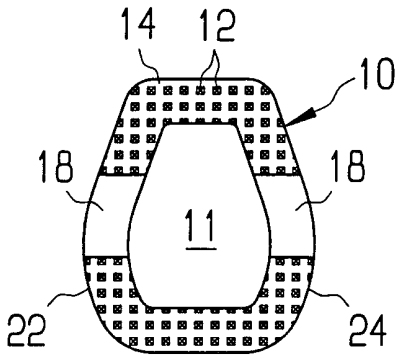

FIG. 2

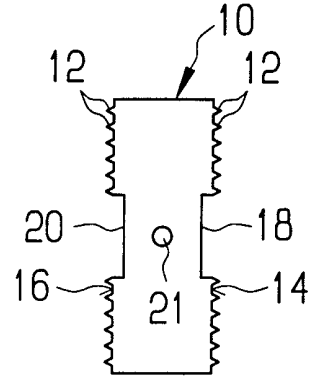

FIG. 3

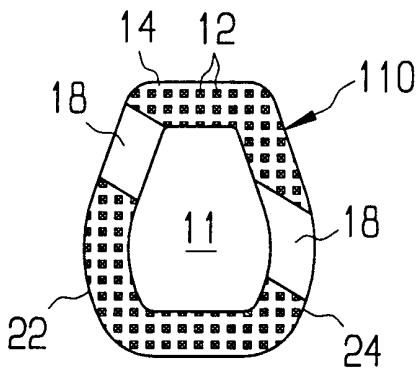

FIG. 4

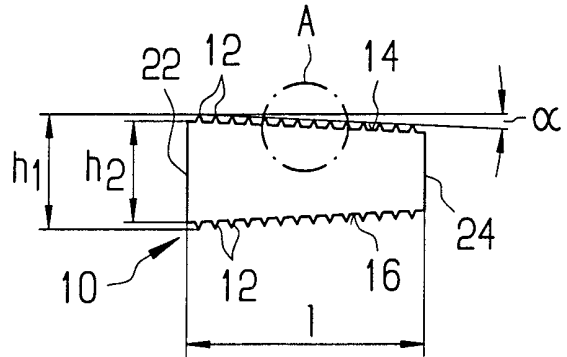

FIG. 5

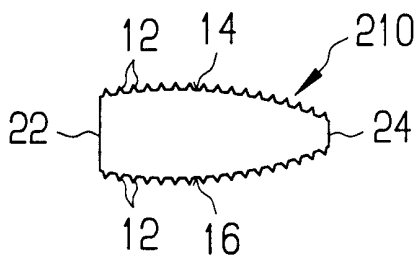

FIG. 6

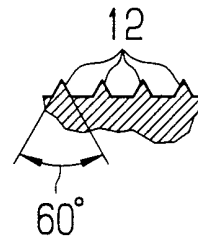

FIG. 7

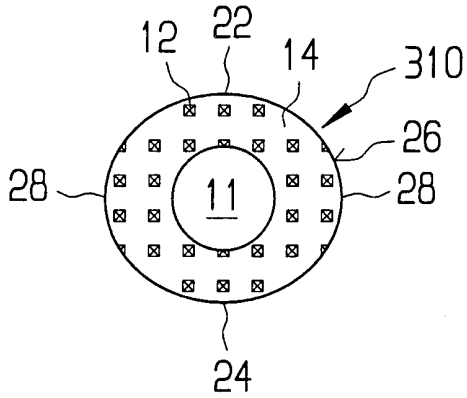

FIG. 8

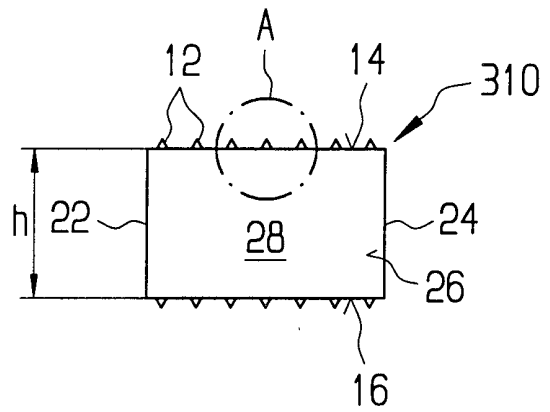

FIG. 9

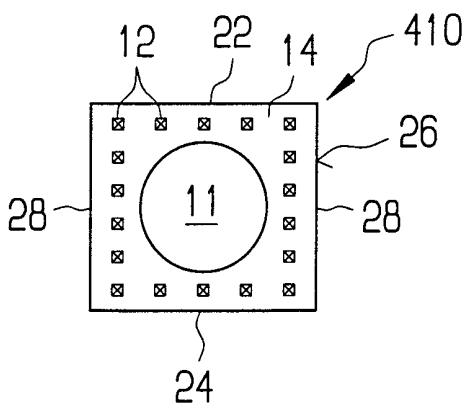

FIG. 10

