

W. Polsgrove,

Boot Crimper.

No. 111,245.

Patented Jan. 24, 1871.

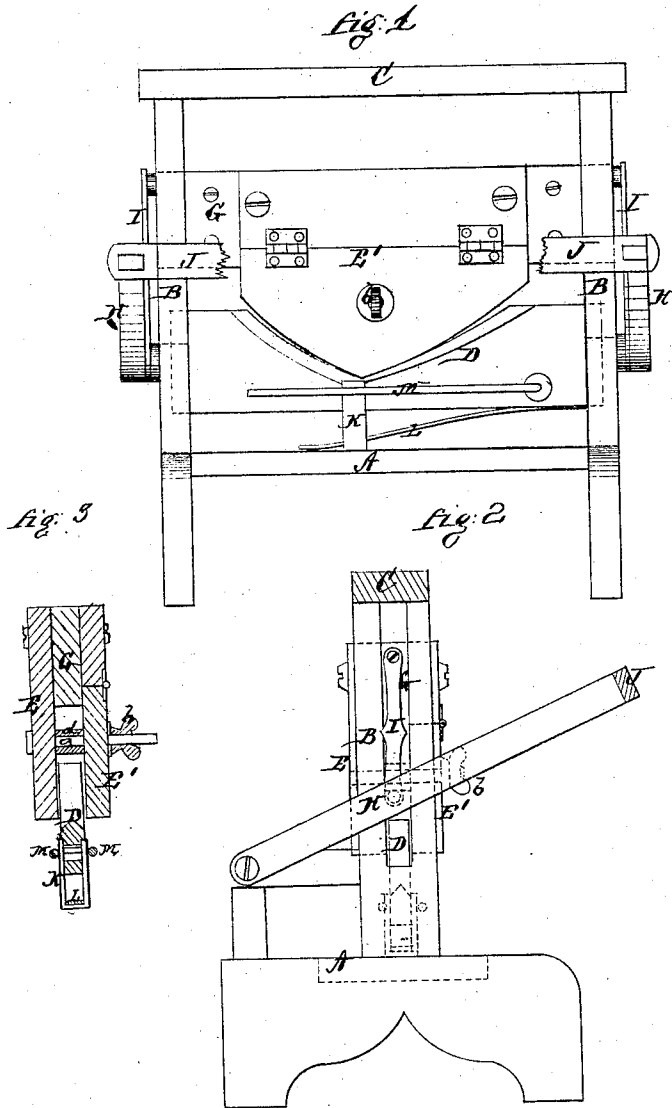

Witnesses.
A. A. Yeatman,
C. L. Querty.

Invento..
William Polsgrove
per Alexander Mason
Atty.

United States Patent Office.

WILLIAM POLSGROVE, OF ST. THOMAS, PENNSYLVANIA.

Letters Patent No. 111,245, dated January 24, 1871.

IMPROVEMENT IN BOOT-CRIMPERS.

The Schedule referred to in these Letters Patent and making part of the same.

To all whom it may concern:

Be it known that I, WILLIAM POLSGROVE, of St. Thomas, in the county of Franklin and in the State of Pennsylvania, have invented certain new and useful Improvements in Boot-Crimper; and do hereby declare that the following is a full, clear, and exact description thereof, reference being had to the accompanying drawing and to the letters of reference marked thereon making a part of this specification.

The nature of my invention consists in the construction and arrangement of a boot-crimper, as will be hereinafter fully set forth.

In order to enable others skilled in the art to which my invention appertains to make and use the same, I will now proceed to describe its construction and operation, referring to the annexed drawing, in which—

Figure 1 is a front elevation, and

Figure 2, an end view of my entire machine.

Figure 3 is a transverse vertical section of the clamp and crimping-board.

A represents the bed of my machine, from which rise two standards, B B, connected at their upper ends by a cross-bar, C.

The standards B B are slotted from their upper ends downward, for a suitable distance, and from the lower ends of said slots grooves extend downward on the inner sides of the standards, in which grooves the ends of the crimping-board D are placed.

In the slotted standards B B moves the clamp or crimper, which is composed of two jaws, E E', or rather, the jaws composing the crimper are attached to a cross-head, G, which moves in the slots, on the standards.

The jaw E, with a portion of the jaw E', are firmly bolted to the cross-head, one on each side, while the remaining or main portion of the jaw E' is hinged to the bolted portion, as shown in figs. 1 and 3.

The hinged jaw E' is connected with the jaw E by means of a bolt *a*, which passes through both, and a thumb-nut, *b*, on the end of said bolt, clamps them together.

A rubber spring, *d*, is placed around the bolt *a*, between the jaws E and E', to hold them apart as far as the thumb-nut *b* will permit.

At the upper ends of small standards, near the rear side of the machine, are pivoted two levers H H, connected at their front ends by a cross-bar, J, and by other bars I I with the ends of the cross-head G, by which means the crimper E E' is lowered and raised at will.

The crimping-board D is provided on each side with a vertical groove extending downward from near the angle of the board, and in said grooves is placed a metallic stirrup, K, of such thickness that it will project slightly beyond the surface of the crimping-board on both sides. This stirrup is held by a pin passing through a slot in the board, as shown in fig. 3.

On the under side of the board D, near one end, is attached a spring, L, which passes through the stirrup K.

Near the lower edge and near one end, through the crimping-board, is passed a spring-wire clamp, M, which extends almost the entire length of the board.

The leather to be crimped is laid across the upper edge of the crimping-board, the stirrup K being first moved up in its grooves as high as it can come. This stirrup fits so tight in these grooves that the spring L, although bearing downward upon it, cannot move it.

When the crimper E E' is now brought down, the points of the same catch on the projecting stirrup and move the same down with the leather as far as it will go, when the crimper slides over it. This causes the leather to be brought clear down smooth, and without a wrinkle, into the angle of the crimping-board, where it always has been most difficult to get the leather properly crimped.

When the leather has been stretched by the crimper, the wire clamp M is brought up, and holds the leather on the board while the crimper is raised again. The spring L now operates to prevent the stirrup K to slide upward.

Having thus fully described my invention,

What I claim as new, and desire to secure by Letters Patent, is—

1. The grooved crimping-board D, provided with the sliding stirrup K, spring L, and clamp M, all substantially as and for the purposes herein set forth.

2. The within-described boot-crimper, consisting of the frame A B C, crimping-board D, with stirrup K, spring L, and clamp M, the cross-head G, with crimper E E', levers H H, and bars I I, all constructed and arranged substantially as and for the purposes herein set forth.

In testimony that I claim the foregoing I have hereunto set my hand this 11th day of November, 1870.

WILLIAM POLSGROVE.

Witnesses:

C. L. EVERT,
A. N. MARR.