

(19)



(11)

EP 1 685 302 B1

(12)

EUROPEAN PATENT SPECIFICATION

(45) Date of publication and mention of the grant of the patent:
24.02.2010 Bulletin 2010/08

(51) Int Cl.:
E04G 3/00 (2006.01)

(21) Application number: **04775511.1**

(86) International application number:
PCT/SE2004/001420

(22) Date of filing: **06.10.2004**

(87) International publication number:
WO 2005/033441 (14.04.2005 Gazette 2005/15)

(54) **APPARATUS FOR FACILIATING NEW CONSTRUCTION AND THE INTERNAL INSPECTION AND REPAIR OF LARGE VESSELS, SUCH AS RECOVERY BOILERS AND TANKS**

VORRICHTUNG ZUR ERLEICHTERUNG DES BAUS, DER INSPEKTION UND DER REPARATUR VON GROSSBEHÄLTERN WIE ZUM BEISPIEL RÜCKGEWINNUNGSKESSELN UND TANKS

APPAREIL FACILITANT LA CONSTRUCTION DE GRANDES CUVES NEUVES AINSI QUE L'INSPECTION INTERNE ET LA REPARATION DE GRANDES CUVES, DU TYPE CHAUDIERES ET RESERVOIRS DE RECUPERATION

(84) Designated Contracting States:
AT BE BG CH CY CZ DE DK EE ES FI FR GB GR HU IE IT LI LU MC NL PL PT RO SE SI SK TR
Designated Extension States:
LT LV

(72) Inventor: **Björklund, Anders**
294 39 Sölvesborg (SE)

(30) Priority: **06.10.2003 SE 0302639**

(74) Representative: **Hjalmarsson, Magnus Axel**
Awapatent AB,
Box 5117
200 71 Malmö (SE)

(43) Date of publication of application:
02.08.2006 Bulletin 2006/31

(56) References cited:
JP-A- 2000 054 618 US-A- 5 007 501

(73) Proprietor: **Björklund, Anders**
294 39 Sölvesborg (SE)

EP 1 685 302 B1

Note: Within nine months of the publication of the mention of the grant of the European patent in the European Patent Bulletin, any person may give notice to the European Patent Office of opposition to that patent, in accordance with the Implementing Regulations. Notice of opposition shall not be deemed to have been filed until the opposition fee has been paid. (Art. 99(1) European Patent Convention).

Description

Field of the Invention

[0001] The present invention relates to an apparatus for facilitating new construction and internal inspection and repair of large vessels, such as recovery boilers and tanks. The apparatus comprises a platform which is vertically adjustably suspended by means of suspension cords hanging down from a roof of the vessel, the platform being built from at least two parallel spaced-apart girders, to which the suspension cords are attached, and at least one plank being arranged perpendicular to the girders and interconnecting the same, the plank resting on the girders and at least partly covering the same.

Background Art

[0002] When large vessels, such as recovery boilers and tanks, are to be built and internally inspected and possibly repaired, the large dimensions thereof always make it necessary to use some kind of scaffold or platform, from which the work can be performed in a safe way. Then there is frequently the problem that the parts included in this scaffold or platform must be inserted through relatively small manholes in the walls or roof of the vessel. Another problem is that the above-mentioned large dimensions require the use of a large number of scaffold or platform parts so that all parts of the vessel can be reached. A further problem is that the parts inside the vessel must frequently be mounted under difficult circumstances, such as high heat inside a boiler. Finally, especially in boilers, there is also the problem that on the one hand some parts of the vessel can be difficult to reach because of what is referred to as a nose which is to be found in certain boilers, i.e. a projecting portion on one of the side walls of the boiler, and on the other hand that it may be necessary to inspect or repair superheaters which are suspended from the roof of the boiler and which between them form narrow passages.

[0003] US-A-5,007,501 discloses an apparatus, which is especially intended for the boiler in a thermal power station and which eliminates some of the problems occurring in the same. More specifically, a smaller number of parts are required for the known apparatus than for a traditional scaffold which is erected standing on the bottom of the large vessel. However, the mounting of the prior-art apparatus is still based on initial mounting from the bottom of the large vessel, still comprises a large number of parts that must be assembled, and does not solve all the problems of accessibility in a satisfactory manner.

[0004] Japanese Published Application JP-A-2000-054618 discloses an apparatus as stated by way of introduction, which eliminates at least one of the problems with the solution according to US-A-5,007,501. The apparatus according to the Japanese publication thus solves the problem with the initial mounting from the bot-

tom of the vessel, but at the same time its applicability is limited significantly by the fact that the footboard, which is formed of said at least one plank, extends only perpendicular to the girders. This greatly limits the applicability and safety of the apparatus when, because of an obstacle, a gap must be left between two neighbouring planks.

Object of the Invention

[0005] In view hereof, the object of the invention is to improve the known apparatus according to JP-A-2000-054618 in such a manner that the remaining problems with this apparatus are eliminated and moreover a considerably more flexible and safer apparatus is provided, which for new construction, inspection and repair is universally applicable to all types of large vessels.

Summary of the Invention

[0006] According to the invention, this is achieved by an apparatus of the type mentioned by way of introduction, said apparatus being **characterised in that** the girders are individually vertically adjustable first lattice girders, to which the suspension cords are attached and which have flat upper sides forming a footboard.

[0007] By the apparatus according to the invention comprising individually vertically adjustable lattice girders, which have a built-in plank for walking, there is provided, in contrast to JP-A-2000-054618, a safe floor surface also along the girders. The lattice girders are insertable in a hanging manner through manholes in the vessel at any level without necessitating setting foot upon the bottom of the vessel. Said at least one plank is then arrangeable in any position between two parallel suspended lattice girders. It will thus be possible to inspect, from the thus provided platform, for instance all walls of a recovery boiler, i.e. also those above the above-mentioned nose, or the superheaters of this boiler all the way up to the roof of the boiler. Owing to the over-length of the plank resting on the girders (it is longer than the normal distance between two juxtaposed girders suspended at the same level), it will be possible within reasonable limits on the one hand to individually lower and raise the lattice girders involved and, on the other hand, to follow the contour of the superheaters which in course of time will frequently be very irregular owing to the high temperatures occurring in the operation of the boiler.

[0008] The girders of the apparatus are preferably rectangular in cross-section, and the suspension cords are suitably attached to them by enclosing holders which enclose the respective girders and have an upper side which has a centrally arranged fastening means for each suspension cord. The advantages of girders that are rectangular in cross-section are that they have an excellent load-carrying capacity, that, if desired, they can easily be connected perpendicular to a corresponding girder of rectangular cross-section, and that outside the vessel

they are stackable in an advantageous way.

[0009] Said enclosing holders each preferably consist of two essentially C-shaped halves, with the C openings facing one another, said halves having at their upper and lower ends lugs, through which locking cotter pins are movable for locking said halves together. Thus designed holders protect in an advantageous manner the girder construction from being damaged by squeezing especially on the sides and ensure, by extending under the girder, that the entire load-carrying capacity of the girder construction can be utilised.

[0010] Preferably, the lugs of the enclosing holders form at the upper ends said fastening means for the suspension cords. It will thus in an advantageous manner be possible to use the same locking cotter pin both for locking together the halves of the enclosing holders and for attaching a suspension cord.

[0011] The halves of the enclosing holders are suitably made of a band material of steel bent to the cross-sectional contour of the girders. Steel has the advantage that it is very stable in shape and has great tensile strength and that it is easy to weld, which considerably facilitates the attachment of the lugs for the locking cotter pins.

[0012] The apparatus according to the invention may, if desired, comprise at least one additional girder, which is of the same type as said first lattice girders and is suspended under at least one of those at a fixed distance. It will thus be easy to provide a platform with several storeys.

[0013] It will be appreciated that the additional girder suitably should be rectangular in cross-section and that it is advantageous if it is suspended by enclosing holders, which enclose the girder and which are suspended from the superposed girder by means of suspension bands arranged on both sides of the girder.

[0014] It will also be appreciated in view of that stated above that the last-mentioned enclosing holders preferably each consist of two substantially C-shaped halves, with the openings facing one another, said halves having at their upper and lower ends lugs, through which locking cotter pins are movable for locking said halves together.

[0015] It goes without saying that also the last-mentioned enclosing holders suitably consist of halves which are made of a band material of steel which is bent to the cross-sectional contour of the additional girder.

[0016] The suspension bands that are used for suspending an additional girder from a superposed girder are preferably steel bands, which at their ends have holes, through which locking cotter pins are movable for locking engagement in corresponding holes in the sides of the enclosing holders of the associated girders. The steel bands are also advantageous because of the good tensile strength of the steel and the fact that the holes formed therein need no extra reinforcement.

[0017] It will be appreciated that the apparatus according to the invention can be extended further by at least one additional girder being suspended under two spaced-apart girders at a fixed distance and by at least

one telescopic plank, arranged perpendicular to the girders, resting on the additional girders and interconnecting the same.

[0018] Said at least one plank is preferably telescopic. The telescopic design makes it easier to adjust the apparatus to different conditions prevailing in the vessel.

[0019] More specifically, the telescopic plank preferably consists of an outer and an inner mutually telescoping U section, which have downwardly directed U openings with ends curved inwards and the projection of which is limited by a pullout-limiting means. The advantage of the ends curved inwards is that they contribute to good mutual displaceability of the U sections since a point charge is avoided. The pullout-limiting means is for natural reasons necessary to prevent the two cooperating U sections from unintentionally sliding apart.

[0020] Said pullout-limiting means suitably comprises at least one spring-biased pin, which for locking is arranged to be automatically moved from the inner U section through lock openings in the legs of the U-shaped sections. This solution has the advantage that the pin construction is well protected inside the contour of the plank, thereby facilitating the handling of the plank.

[0021] Preferably the outer U section has, at an end which is adapted to rest on a girder, at least one vertical hole for insertion of a locking cotter pin, which is arranged to engage in a corresponding hole in the upper side of the girder. This type of securing of the plank relative to the girder is important especially for the outermost girder of a platform construction.

[0022] The suspension cords are suitably chains hanging down from electrically operated telfers arranged on the roof of the vessel. Advantages of chains are that, in contrast to wires that are used according to US-A-5,007,501, they cannot be untwined and that they can be handled with greater accuracy by chain telfers than wires which are wound in layers by a wire winch.

[0023] Finally, the telfers are preferably individually remote controlled from the interior of the vessel. It will thus be easily possible to vertically adjust individual girders inside the vessel.

Brief Description of the Drawings

[0024] A preferred embodiment of the apparatus according to the invention will in the following be described in more detail with reference to the accompanying schematic drawings, in which

Fig. 1 is side view with partly broken-away components and illustrates parts of a recovery boiler, in which an apparatus according to the invention is used;

Fig. 2 is a side view and illustrates parts of the long side of a lattice girder;

Fig. 3 is a top plan view and illustrates parts of the upper side of the lattice girder;

Fig. 4 is an end view and illustrates three lattice gird-

ers arranged one above the other, which are interconnected by means of steel bands arranged on the sides;

Fig. 5 is an end view and illustrates a first enclosing holder with associated locking cotter pins;

Fig. 6 is an end view and illustrates a second enclosing holder with an associated locking cotter pin;

Fig. 7 is a top plan view and illustrates parts of the upper side of a telescopic plank;

Fig. 8 is a side view and illustrates parts of the long side of the telescopic plank; and

Fig. 9 is a sectional view and illustrates parts of the upper side of the plank.

Description of a Preferred Embodiment

[0025] Fig. 1 illustrates parts of a pressure vessel 1 for a recovery boiler, in which an apparatus according to the invention is used for inspection and repair purposes. However, it would be possible to use the apparatus for the same purpose also in other types of pressure vessels, such as a bark-fired boiler, or inside a vessel, such as an oil tank. Moreover, it can be used in new construction of such vessels.

[0026] The pressure vessel 1 in Fig. 1 has, among other things, walls 2 with manholes 3 formed therein, a so-called nose 4 mentioned by way of introduction, a protective roof 5 and a roof 6, from which a number of superheaters 7 are suspended.

[0027] The superheater 7 constitutes one of the parts that are of special interest to be examined in connection with an inspection. However, they make such inspection difficult by forming, between them, narrow vertical passages, which may have a height of several meters and are partly positioned above the nose 4. Some of the passages extend parallel to the plane of the drawing in Fig. 1, and some 8 extend vertically to this plane. The manholes 3 are preferably arranged at least at one end of the passages 8.

[0028] The apparatus according to the invention is shown in Fig. 1 to the right and to the left in the form of two platforms 10 with slightly different configurations. A common feature of the two platforms 10 is that the components included therein are identical since they constitute parts of a construction kit which can be extended as desired to be adjusted to the prevailing situation.

[0029] Each platform 10 includes lattice girders 11 and telescopic planks 12 as the main components.

[0030] Of the girders 11, the uppermost are horizontally suspended parallel to each other both in the passages 8 and outside the same by chains 13 hanging down from electric telfers 14 mounted on the roof 6 of the vessel 1. The telfers are remote controlled and can advantageously be used, for instance, in order to initially pull in a girder into the vessel 1 through a suitable manhole 3. The lower girders 11 are suspended from the superposed girders 11 by means of steel bands 15 which are arranged on both sides of the girders 11. The sus-

pension of both the upper and the lower girders 11 will be described in more detail below with reference to Figs 4-6, and the construction of the girders 11 will be discussed below with reference to Figs 2-4.

[0031] The telescopic planks 12 shown in Fig. 1 rest on girders 11 hanging at essentially the same level, and extend, seen from above, perpendicular to these girders 11. They are thus arranged perpendicular also to the passages 8 and can therefore be used to reach the passages (those parallel to the plane of the drawing) which are perpendicular to these passages 8. The construction of the planks 12 will be described in detail below with reference to Figs 7-9.

[0032] Fig. 2 is a side view of a part of a lattice girder 11, Fig. 3 is a top plan view of a corresponding part, and Fig. 4 is an end view of a plurality of such girders 11. The girder 11, which is rectangular in cross-section, is made of aluminium and comprises four longitudinal main pipes 16 arranged in the cross-sectional corners. A grid structure of thinner pipes or rods 17, which stabilises the main pipes 16, extends between these main pipes 16 in a zig-zag. On top of the two upper main pipes 16, a footboard plate 18 is attached, which has a grooved anti-skid upper side 19. At the ends of the girder 11, coupling means (not shown) of prior-art type can be arranged for a possible extension of the girder 11 or for connection of a ladder for instance.

[0033] For suspension of the girders 11, use is made, as stated above, of chains 13 for the upper girders 11 and steel bands 15 for the lower girders 11. The chains 13 as well as the steel bands 15 are attached, as is evident from Fig. 4, to the girders 11 by enclosing holders 20, 21, of which the holder 20 is intended especially for the upper girders 11 and is shown in more detail in Fig. 5, and the holder 21 is intended for the lower girders 11 and is shown in more detail in Fig. 6.

[0034] The holder 20 comprises two essentially C-shaped halves 22, 23 shaped according to the cross-sectional contour of the lattice girder 11, with the openings facing one another, said halves being made of a bent band material of steel. Said halves 22, 23 have lugs 24, 25 at their upper ends and lugs 26, 27 at their lower ends, which at the upper ends consist of vertically upwardly bent portions of the band material and which at the lower ends consist of tubular sleeves which are welded to the band material. A cotter pin 28 is moved through the lugs 24, 25 for attaching the above-mentioned chains 13, said cotter pin suitably belonging to a shackle 29, into which a hook 30 at the lower end of a chain 14 can be hooked. At the lower ends, the lugs 26, 27 are preferably connected to each other by means of a locking cotter pin 31, which is moved through the tubular sleeves and then locked.

[0035] The holder 21 also comprises two essentially C-shaped halves 32, 33 shaped according to the cross-sectional contour of the lattice girder 11, with the openings facing one another, said halves being made of a bent band material of steel. Said halves 32, 33 have lugs

34, 35 at their upper ends and lugs 36, 37 at their lower ends, which at both the upper and the lower ends consist of tubular sleeves which are welded to the band material. The lugs 34-37 are preferably connected to each other by means of locking cotter pins 38 which are moved through the tubular sleeves and then locked.

[0036] To attach the above-mentioned steel bands 15 to the sides of the girders 11, the steel bands 15 have holes 39 formed at their ends, and both the holder 20 and the holder 21 have holes 40 formed in their sides, through which locking cotter pins 41 can be moved and then be locked.

[0037] Fig. 7 is a top plan view of a part of a telescopic plank 12, Fig. 8 is a side view of a corresponding part, and Fig. 9 is a sectional view of a part of the plank 12 corresponding to the situation in Fig. 7. The plank 12 consists of an outer and an inner mutually telescoping U section 42, 43, which have downwardly directed U openings with ends 44, 45 curved inwards, which give the telescopic plank 12 a good load-bearing capacity. For reasons of safety, the sections 42, 43 have a grooved anti-skid surface 46, 47 and a pullout-limiting means 48 for limiting the possible projection.

[0038] The pullout-limiting means 48 comprises two pins 50 which are biased by means of a leaf spring 49 and which for locking are arranged to be automatically moved from the inner U section 43 through lock openings 51, 52 in the legs of the U-shaped sections 42, 43. To allow simple release, the pins 50 are fixedly connected to a cable 53 which is connected to both pins 50 and thus allows simultaneous release of the two pins 50.

[0039] The sections 42, 43, preferably the outer section 42, can also, for reasons of safety, at one end which is adapted to rest on a girder 11 have at least one vertical hole for insertion of a locking cotter pin, which is arranged to engage in a corresponding hole in the upper side of the girder 11.

[0040] A person skilled in the art will realise that the above-described embodiment of the invention may be varied in many ways within the scope of the claims, and that the above-described platforms 10, depending on the number of planks 12 that are arranged and the number of girders 11 arranged under and next to each other are usable for most operations which are to be performed in the vessels at issue and in which a scaffold is required.

Claims

1. An apparatus for facilitating new construction as well as internal inspection and repair of large vessels (1), such as recovery boilers and tanks, said apparatus comprising a platform (10) which is vertically adjustably suspended by means of suspension cords (13) hanging down from a roof (6) of the vessel (1), the platform (10) being built from at least two parallel spaced-apart girders (11), to which the suspension cords (13) are attached, and at least one plank (12)

being arranged perpendicular to the girders (11) and interconnecting the same, the plank resting on the girders (11) and at least partly covering the same, **characterised in that** the girders (11) are individually vertically adjustable first lattice girders (11), to which the suspension cords (13) are attached and which have flat upper sides forming a footboard (18).

2. An apparatus as claimed in claim 1, **characterised in that** the girders (11) are rectangular in cross-section, and that the suspension cords (13) are attached thereto by enclosing holders (20) which enclose the respective girders (11) and have an upper side which has a centrally arranged fastening means (24, 25) for each suspension cord (13).
3. An apparatus as claimed in claim 2, **characterised in that** the enclosing holders (20) each consist of two essentially C-shaped halves (22, 23), with the C openings facing one other, said halves having at their upper and lower ends lugs (24-27), through which locking cotter pins (28-31) are movable for locking said halves (22, 23) together.
4. An apparatus as claimed in claim 3, **characterised in that** the lugs (24, 25) at the upper ends form said fastening means.
5. An apparatus as claimed in claim 3 or 4, **characterised in that** said halves (22, 23) are made of a band material of steel bent to the cross-sectional contour of the girders (11).
6. An apparatus as claimed in any one of claims 1-5, **characterised in that** at least one additional girder (11), which is of the same type as said first lattice girders (11), is suspended under at least one of those at a fixed distance.
7. An apparatus as claimed in claim 6, **characterised in that** the additional girder (11) is rectangular in cross-section, and that it is suspended by enclosing holders (21) which enclose the girder and which are suspended from the superposed girder (11) by means of suspension bands (15) arranged on both sides of the girder (11).
8. An apparatus as claimed in claim 7, **characterised in that** the enclosing holders (21) each consist of two essentially C-shaped halves (32, 33), with the openings facing one another, said halves having at their upper and lower ends lugs (34-37), through which locking cotter pins (38) are movable for locking said halves (32, 33) together.
9. An apparatus as claimed in claim 7 or 8, **characterised in that** said halves (32, 33) are made of a band material of steel bent to the cross-sectional contour

of the additional girder (11).

10. An apparatus as claimed in any one of claims 2-5 and any one of claims 6-8, **characterised in that** the suspension bands are steel bands (15), which at their ends have holes (39), through which locking cotter pins (41) are movable for locking engagement in corresponding holes (40) in the sides of the enclosing holders (20, 21) of the associated girders (11).
11. An apparatus as claimed in any one of claims 6-10, **characterised in that** at least one additional girder (11) is suspended under two spaced-apart girders (11) at a fixed distance, and that at least one plank (12) is arranged perpendicular to the girders (11) and interconnecting the girders (11), said plank resting on the additional girders (11) and at least partly covering the same.
12. An apparatus as claimed in any one of claims 1-11, **characterised in that** said at least one plank (12) is telescopic.
13. An apparatus as claimed in claim 12, **characterised in that** the telescopic plank (12) consists of an outer and an inner mutually telescoping U section (42, 43), which have downwardly directed U openings with ends (44, 45) curved inwards and the projection of which is limited by a pullout-limiting means (48).
14. An apparatus as claimed in claim 13, **characterised in that** the pullout-limiting means (48) comprises at least one spring-biased pin (50), which for locking is arranged to be automatically moved from the inner U section (43) through lock openings (51, 52) in the legs of the U-shaped sections (42, 43).
15. An apparatus as claimed in claim 13 or 14, **characterised in that** the outer U section (42) at an end which is adapted to rest on a girder (11) has at least one vertical hole for insertion of a locking cotter pin, which is arranged to engage in a corresponding hole in the upper side of the girder (11).
16. An apparatus as claimed in any one of claims 1-15, **characterised in that** the suspension cords are chains (13) hanging down from electrically operated telfers (14) which are arranged on the roof (6) of the vessel (1).
17. An apparatus as claimed in claim 16, **characterised in that** the telfers (14) are individually remote controlled from the interior of the vessel (1).

Patentansprüche

1. Vorrichtung zum Erleichtern des Baus sowie der inneren Inspektion und der Reparatur von großen Behältern (1), beispielsweise von Sodahausdampfkes-
5 seln und Tanks, wobei die Vorrichtung eine Plattform (10) umfasst, die mittels Aufhängeseilen (13), welche von einem Dach (6) des Behälters (1) herunterhängen, vertikal einstellbar aufgehängt ist, wobei die Plattform (10) gebaut ist aus mindestens zwei parallelen, voneinander beabstandeten Trägern (11), an denen die Aufhängeseile (13) befestigt sind, und mindestens einer Planke (12), die im rechten Winkel zu den Trägern (11) angeordnet ist und diese miteinander verbindet, wobei die Planke auf den Trägern (11) aufliegt und diese mindestens zum Teil bedeckt, **dadurch gekennzeichnet, dass** die Träger (11) einzeln vertikal einstellbare erste Gitterträger (11) sind, an denen die Aufhängeseile (13) befestigt sind und die flache Oberseiten aufweisen, welche ein Trittbrett (18) bilden.
2. Vorrichtung nach Anspruch 1, **dadurch gekennzeichnet, dass** die Träger (11) einen rechteckigen Querschnitt aufweisen und dass die Hängeseile (13) daran durch umgebende Halterungen (20) befestigt sind, welche die jeweiligen Träger (11) umgeben und eine Oberseite aufweisen, die ein mittig angeordnetes Befestigungsmittel (24, 25) für jedes Aufhänge-
20 seil (13) aufweist.
3. Vorrichtung nach Anspruch 2, **dadurch gekennzeichnet, dass** die umgebenden Halterungen (20) jeweils aus zwei im Wesentlichen C-förmigen Hälften (22, 23) bestehen, wobei die C-Öffnungen einander zugewandt sind, wobei die Hälften an deren oberen und unteren Enden Ösen (24-27) aufweisen, durch welche verriegelnde Splinte (28-31) bewegt werden können, um die Hälften (22, 23) miteinander zu verriegeln.
4. Vorrichtung nach Anspruch 3, **dadurch gekennzeichnet, dass** die Ösen (24, 25) an den oberen Enden das Befestigungsmittel bilden.
5. Vorrichtung nach Anspruch 3 oder 4, **dadurch gekennzeichnet, dass** die Hälften (22, 23) aus einem Bandmaterial aus Stahl hergestellt sind, welches zu der Querschnittskontur der Träger (11) gebogen ist.
6. Vorrichtung nach einem beliebigen der Ansprüche 1-5, **dadurch gekennzeichnet, dass** mindestens ein zusätzlicher Träger (11), der von demselben Typ wie die ersten Gitterträger (11) ist, in einem festen Abstand unter mindestens einem dieser aufgehängt ist.
7. Vorrichtung nach Anspruch 6, **dadurch gekenn-**

- zeichnet, dass** der zusätzliche Träger (11) einen rechteckigen Querschnitt aufweist und dass er anhand von umgebenden Halterungen (21) aufgehängt ist, welche den Träger umgeben und mittels Aufhängebändern (15), die an beiden Seiten des Trägers (11) angeordnet sind, von dem darüber angeordneten Träger (11) abgehängt sind.
8. Vorrichtung nach Anspruch 7, **dadurch gekennzeichnet, dass** die umgebenden Halterungen (21) jeweils aus zwei im Wesentlichen C-förmigen Hälften (32, 33) bestehen, wobei die Öffnungen einander zugewandt sind, wobei die Hälften an deren oberen und unteren Enden Ösen (34-37) aufweisen, durch welche verriegelnde Splinte (38) bewegt werden können, um die Hälften (32, 33) miteinander zu verriegeln.
9. Vorrichtung nach Anspruch 7 oder 8, **dadurch gekennzeichnet, dass** die Hälften (32, 33) aus einem Bandmaterial aus Stahl hergestellt sind, welches zu der Querschnittskontur des zusätzlichen Trägers (11) gebogen ist.
10. Vorrichtung nach einem beliebigen der Ansprüche 2-5 und einem beliebigen der Ansprüche 6-8, **dadurch gekennzeichnet, dass** die Aufhängebänder Stahlbänder (15) sind, die an deren Enden Löcher (39) aufweisen, durch welche verriegelnde Splinte (41) für einen verriegelnden Eingriff in entsprechenden Löchern (40) in den Seiten der umgebenden Halterungen (20, 21) der zugeordneten Träger (11) bewegt werden können.
11. Vorrichtung nach einem beliebigen der Ansprüche 6-10, **dadurch gekennzeichnet, dass** mindestens ein zusätzlicher Träger (11) in einem festen Abstand unter zwei voneinander beabstandeten Trägern (11) aufgehängt ist und dass mindestens eine Planke (12) im rechten Winkel zu den Trägern (11) angeordnet ist und die Träger (11) miteinander verbindet, wobei die Planke auf den zusätzlichen Trägern (11) aufliegt und diese mindestens zum Teil bedeckt.
12. Vorrichtung nach einem beliebigen der Ansprüche 1-11, **dadurch gekennzeichnet, dass** die mindestens eine Planke (12) teleskopisch ist.
13. Vorrichtung nach Anspruch 12, **dadurch gekennzeichnet, dass** die teleskopische Planke (12) aus einem äußeren und einem inneren U-Profil (42, 43), die teleskopisch ineinander verschieblich sind, besteht, welche nach unten gewandte U-Öffnungen mit nach innen gekrümmten Enden (44, 45) aufweisen und deren Ausziehweite durch ein Ausziehbegrenzungsmittel (48) begrenzt wird.
14. Vorrichtung nach Anspruch 13, **dadurch gekennzeichnet, dass** das Ausziehbegrenzungsmittel (48) mindestens einen federbelasteten Stift (50) umfasst, der zum Verriegeln derart angeordnet ist, dass er von dem inneren U-Profil (43) aus automatisch durch Verriegelungsöffnungen (51, 52) in den Schenkeln der U-förmigen Profile (42, 43) bewegt wird.
15. Vorrichtung nach Anspruch 13 oder 14, **dadurch gekennzeichnet, dass** das äußere U-Profil (42) an einem Ende, welches ausgebildet ist, um auf einem Träger (11) aufzuliegen, mindestens ein vertikales Loch zum Einführen eines verriegelnden Splints aufweist, der angeordnet ist, um in ein entsprechendes Loch in der Oberseite des Trägers (11) einzugreifen.
16. Vorrichtung nach einem beliebigen der Ansprüche 1-15, **dadurch gekennzeichnet, dass** die Hängeseile Ketten (13) sind, die von elektrisch betriebenen Kettenzügen (14) herabhängen, welche auf dem Dach (6) des Behälters (1) angeordnet sind.
17. Vorrichtung nach Anspruch 16, **dadurch gekennzeichnet, dass** die Kettenzüge (14) von dem Inneren des Behälters (1) aus einzeln ferngesteuert werden.

Revendications

1. Appareil pour la facilitation de nouvelles constructions et l'inspection et la réparation interne de grandes cuves (1), telles que des chaudières de récupération et des citernes, ledit appareil comprenant une plateforme (10) suspendue à une hauteur réglable par des cordes de suspension (13) qui pendent vers le bas à partir d'un toit (6) de la cuve (1), la plateforme (10) étant constituée d'au moins deux poutres parallèles (11) espacées entre elles, auxquelles sont attachées les cordes de suspension (13), et au moins une planche (12) disposée perpendiculairement aux poutres (11) et reliant ces dernières, la planche reposant sur les poutres (11) en les recouvrant au moins partiellement, **caractérisé en ce que** les poutres (11) sont des premières poutres de charpente (11) individuellement réglables dans la verticale, auxquelles sont attachées les cordes de suspension (13) et possédant des faces supérieures plates formant un marche-pied (18).
2. Appareil selon la revendication 1, **caractérisé en ce que** les poutres (11) présentent une section transversale rectangulaire, et **en ce que** les cordes de suspension (13) sont attachées à celles-ci par des supports enrobants (20) entourant chacune des poutres (11) et possédant un côté supérieur avec des moyens de fixation (24, 25) disposés de façon centrale pour chaque corde de suspension (13).

3. Appareil selon la revendication 2, **caractérisé en ce que** les supports enrobants (20) sont chacun composés de deux moitiés essentiellement en forme de C (22, 23), avec les ouvertures C situées l'une en face de l'autre, lesdites moitiés possédant des saillies (24-27) à leurs extrémités supérieure et inférieure, au moyen desquelles des goupilles de blocage (28-31) sont déplaçables pour bloquer les deux moitiés (22, 23) ensemble.
4. Appareil selon la revendication 3, **caractérisé en ce que** les saillies (24, 25) aux extrémités supérieures forment lesdits moyens de fixation.
5. Appareil selon l'une des revendications 3 ou 4, **caractérisé en ce que** lesdites moitiés (22, 23) sont constituées d'une bande d'acier courbée vers le contour de la section transversale des poutres (11).
6. Appareil selon l'une quelconque des revendications 1 à 5, **caractérisé en ce qu'**au moins une poutre supplémentaire (11), du même type que lesdites premières poutres (11), est suspendue en-dessous d'au moins l'une de celles-ci, à une distance déterminée.
7. Appareil selon la revendication 6, **caractérisé en ce que** la poutre supplémentaire (11) présente une section transversale rectangulaire, et **en ce qu'**elle est suspendue par des supports enrobants (21) entourant la poutre et suspendus aux poutres superposées (11) au moyen de bandes de suspension (15) disposées des deux côtés de la poutre (11).
8. Appareil selon la revendication 7, **caractérisé en ce que** les supports enrobants (21) sont chacun constitués de deux moitiés (32, 33) essentiellement en forme de C, avec les ouvertures situées l'une en face de l'autre, lesdites moitiés possédant des saillies (34-37) à leurs extrémités supérieures et inférieures, au moyen desquelles des goupilles de blocage (38) sont déplaçables pour bloquer lesdites moitiés (32, 33) ensemble.
9. Appareil selon l'une des revendications 7 ou 8, **caractérisé en ce que** lesdites moitiés (32, 33) sont constituées d'une bande d'acier courbée vers le contour de la section transversale de la poutre supplémentaire (11).
10. Appareil selon l'une quelconque des revendications 2 à 5 et l'une quelconque des revendications 6 à 8, **caractérisé en ce que** les bandes de suspension sont des bandes d'acier (15) possédant des orifices (39) à leurs extrémités, au moyen desquels des goupilles de blocage (41) sont déplaçables pour un bloquer l'engagement dans des orifices correspondants (40) dans les côtés des supports enrobants (20, 21) des poutres (11) associées.
11. Appareil selon l'une quelconque des revendications 6 à 10, **caractérisé en ce que** l'au moins une poutre supplémentaire (11) est suspendue en-dessous de deux poutres espacées (11) à une distance déterminée, et **en ce qu'**au moins une planche (12) est disposée perpendiculairement aux poutres (11), en reliant les poutres (11), ladite planche reposant sur les poutres supplémentaires (11) en les recouvrant au moins partiellement.
12. Appareil selon l'une quelconque des revendications 1 à 11, **caractérisé en ce que** l'au moins une planche (12) est télescopique.
13. Appareil selon la revendication 12, **caractérisé en ce que** la planche télescopique (12) est constituée d'une section en U extérieure et d'une section en U intérieure mutuellement télescopiques (42, 43), possédant des ouvertures en U dirigées vers le bas, avec des extrémités (44, 45) courbées vers l'intérieur et dont la projection est protégée par un moyen anti-arrachement (48).
14. Appareil selon la revendication 13, **caractérisé en ce que** le moyen anti-arrachement (48) comprend au moins une cheville déviée par ressort (50), qui pour le blocage est conçue de manière à pouvoir être déplacée automatiquement de la section en U intérieure (43) par des ouvertures de blocage (51, 52) dans les branches des sections en U (42, 43).
15. Appareil selon l'une des revendications 13 ou 14, **caractérisé en ce que** la section en U extérieure (42) à une extrémité adaptée pour reposer sur une poutre (11) possède au moins un orifice vertical pour l'insertion d'une goupille de blocage, conçue pour s'engager dans un orifice correspondant dans le côté supérieur de la poutre (11).
16. Appareil selon l'une quelconque des revendications 1 à 15, **caractérisé en ce que** les cordes de suspension sont des chaînes (13) pendant vers le bas à partir de palans à chaînes (14) actionnés de façon électrique et installés sur le toit (6) de la cuve (1).
17. Appareil selon la revendication 16, **caractérisé en ce que** les palans à chaînes (14) sont individuellement contrôlés à distance, depuis l'intérieur de la cuve (1).

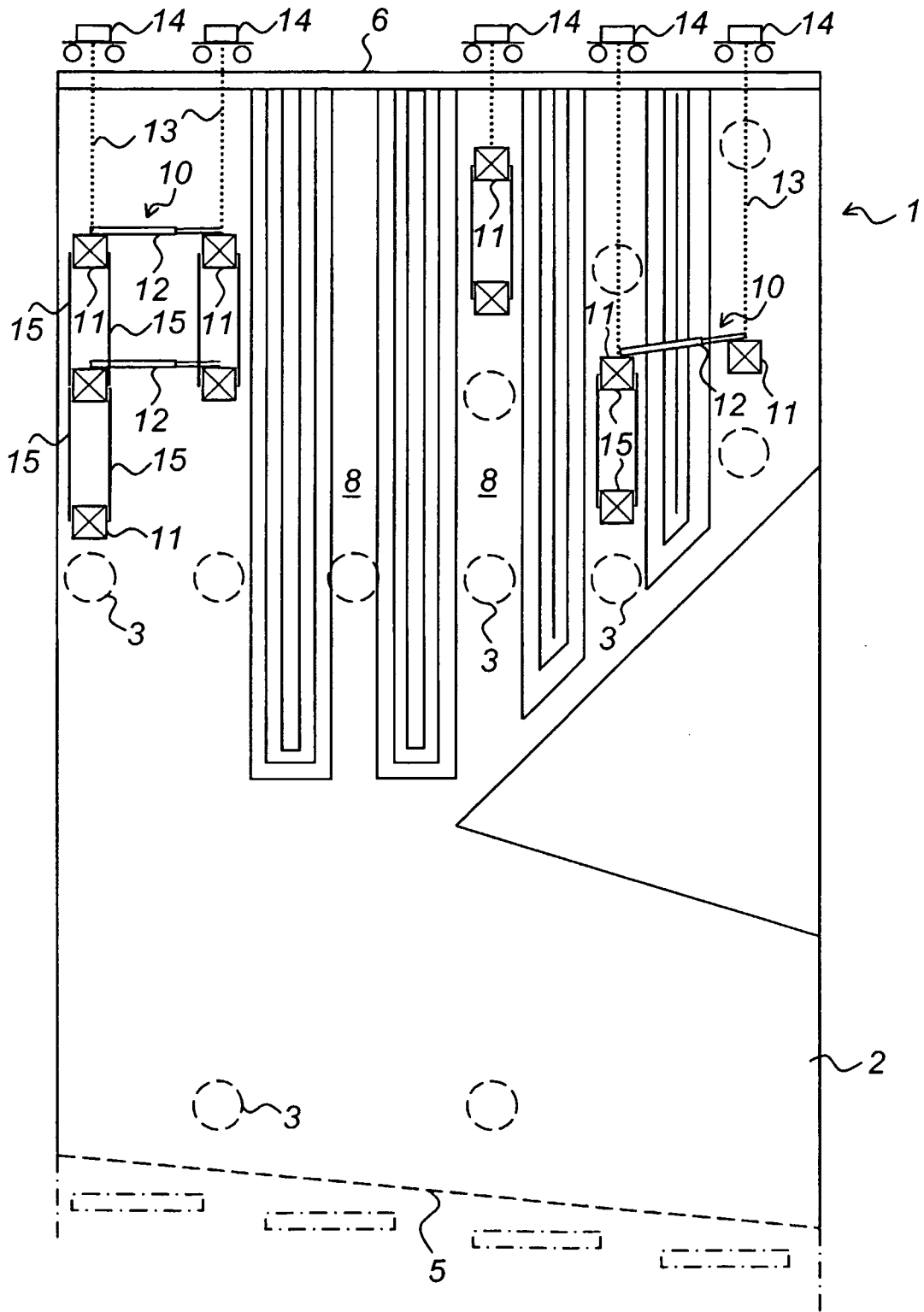

Fig 1

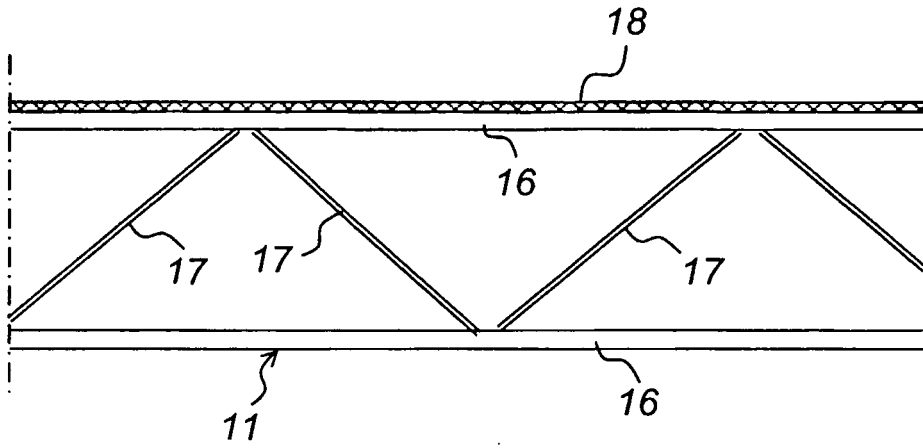

Fig 2

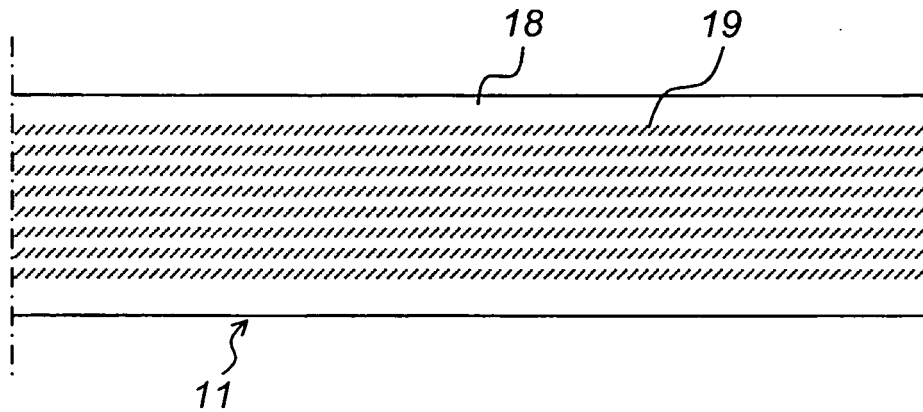
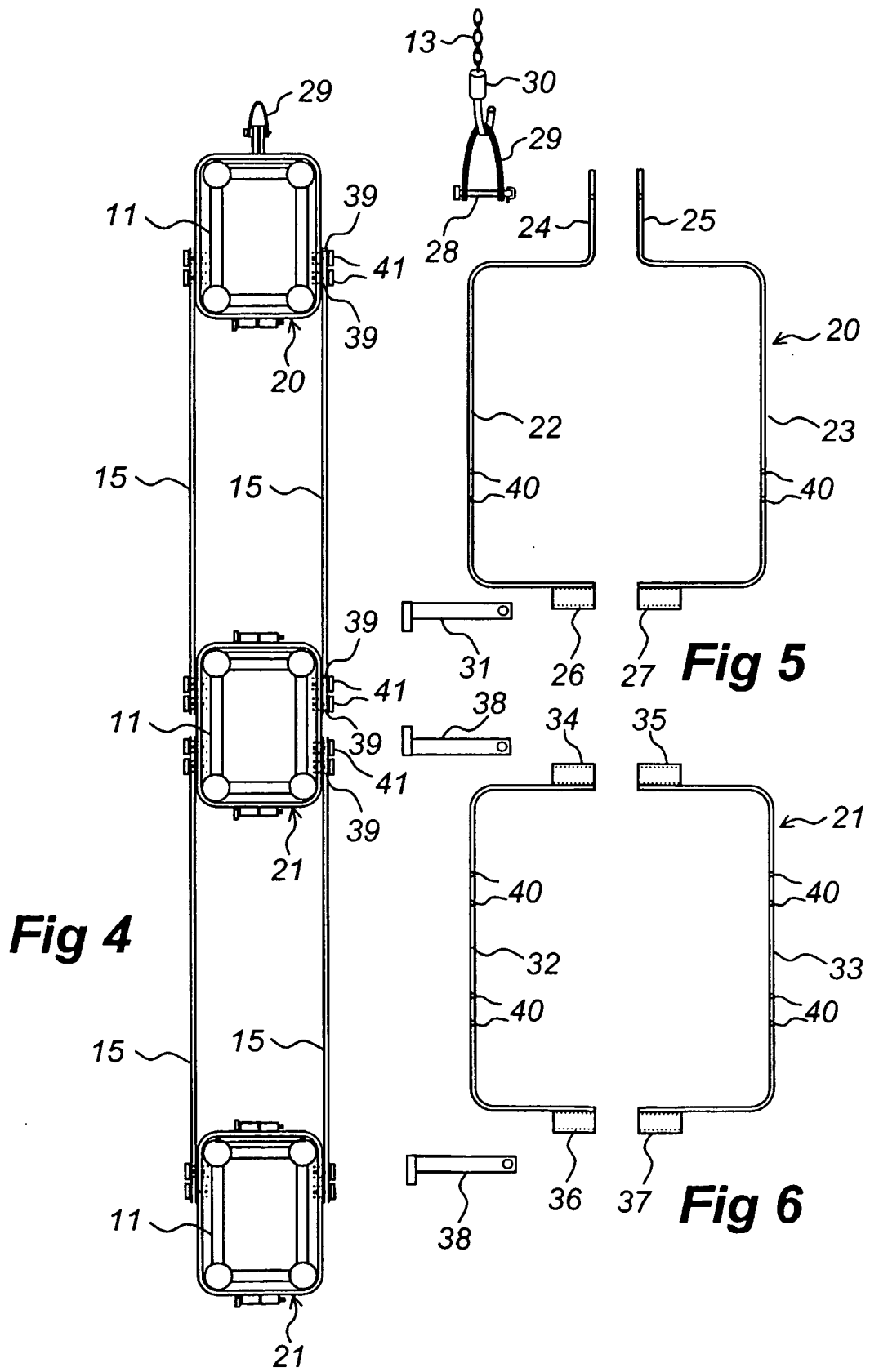

Fig 3



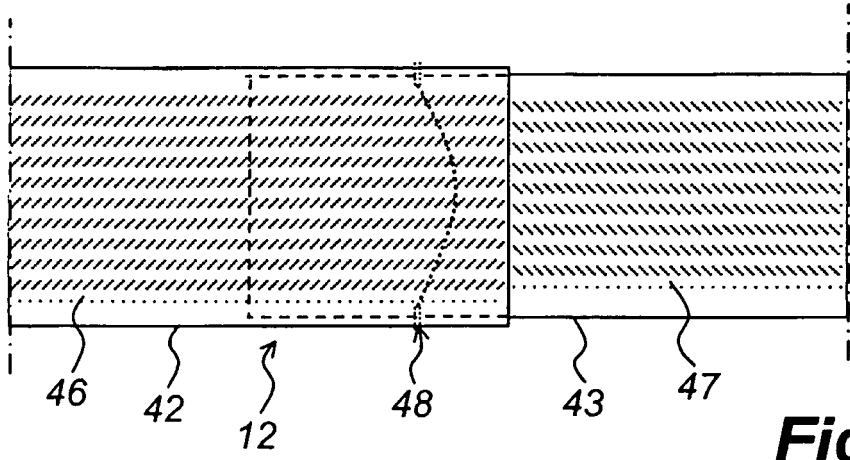

Fig 7

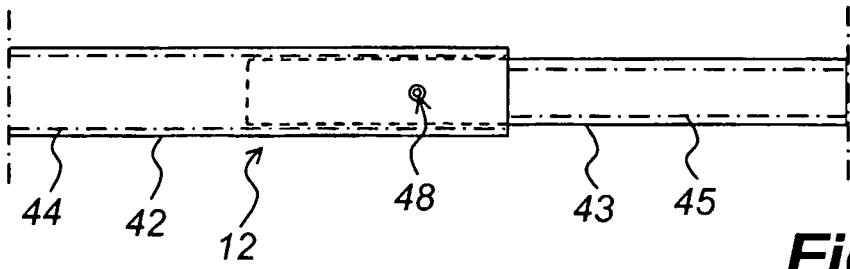

Fig 8

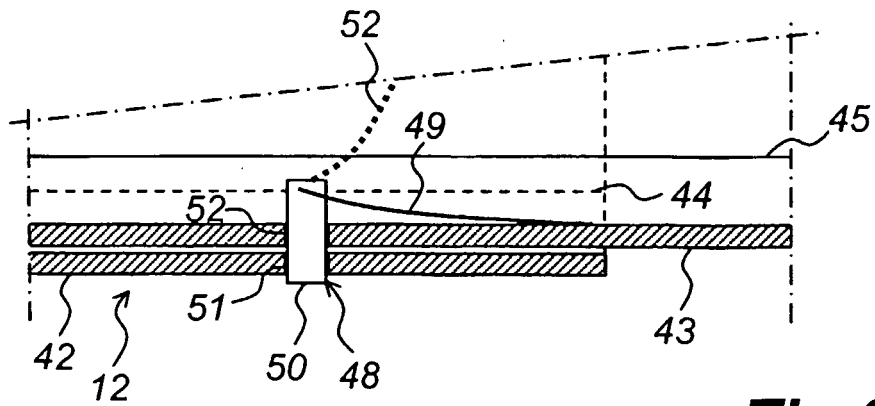

Fig 9

REFERENCES CITED IN THE DESCRIPTION

This list of references cited by the applicant is for the reader's convenience only. It does not form part of the European patent document. Even though great care has been taken in compiling the references, errors or omissions cannot be excluded and the EPO disclaims all liability in this regard.

Patent documents cited in the description

- US 5007501 A [0003] [0004] [0022]
- JP 2000054618 A [0004] [0005] [0007]