



HU000035755T2

(19) **HU**(11) Lajstromszám: **E 035 755**(13) **T2****MAGYARORSZÁG**
Szellemi Tulajdon Nemzeti Hivatala**EURÓPAI SZABADALOM**
SZÖVEGÉNEK FORDÍTÁSA(21) Magyar ügyszám: **E 09 791345**(51) Int. Cl.: **H04W 72/04** (2006.01)(22) A bejelentés napja: **2009. 08. 10.**

(86) A nemzetközi (PCT) bejelentési szám:

PCT/US 09/053318

(96) Az európai bejelentés bejelentési száma:

EP 20090791345

(87) A nemzetközi közzétételi szám:

WO 10019524

(97) Az európai bejelentés közzétételi adatai:

EP 2324676 A2 2010. 02. 18.

(97) Az európai szabadalom megadásának meghirdetési adatai:

EP 2324676 B1 2017. 06. 21.

(30) Elsőbbségi adatok:

87953 P 2008. 08. 11. US**120232 P** 2008. 12. 05. US**536637** 2009. 08. 06. US

(73) Jogosult(ak):

QUALCOMM Incorporated, San Diego, CA
92121 (US)

(72) Feltaláló(k):

DAMNJANOVIC, Jelena, M., San Diego CA 92121 (US)**MONTOJO, Juan, San Diego CA 92121 (US)****SARKAR, Sandip, San Diego CA 92121 (US)**

(74) Képviselő:

Danubia Szabadalmi és Jogi Iroda Kft.,
Budapest

(54)

Horgony vivő többvívós vezeték nélküli kommunikációs rendszerben

Az európai szabadalom ellen, megadásának az Európai Szabadalmi Közlönyben való meghirdetésétől számított kilenc hónapon belül, felszólalást lehet benyújtani az Európai Szabadalmi Hivatalnál. (Európai Szabadalmi Egyezmény 99. cikk(1))

A fordítást a szabadalmat az 1995. évi XXXIII. törvény 84/H. §-a szerint nyújtotta be. A fordítás tartalmi helyességét a Szellemi Tulajdon Nemzeti Hivatala nem vizsgálta.

(19)



(11)

EP 2 324 676 B1

(12)

EUROPEAN PATENT SPECIFICATION

(45) Date of publication and mention of the grant of the patent:
21.06.2017 Bulletin 2017/25

(51) Int Cl.:
H04W 72/04 (2009.01)

(21) Application number: **09791345.3**

(86) International application number:
PCT/US2009/053318

(22) Date of filing: **10.08.2009**

(87) International publication number:
WO 2010/019524 (18.02.2010 Gazette 2010/07)

(54) **ANCHOR CARRIER IN A MULTIPLE CARRIER WIRELESS COMMUNICATION SYSTEM**
 ANKERTRÄGER IN EINEM DRAHTLOSEN MEHRFACHTRÄGER-KOMMUNIKATIONSSYSTEM
 PORTEUSE D'ANCRAGE DANS UN SYSTÈME DE COMMUNICATION SANS FIL À MULTIPLES PORTEUSES

(84) Designated Contracting States:
AT BE BG CH CY CZ DE DK EE ES FI FR GB GR HR HU IE IS IT LI LT LU LV MC MK MT NL NO PL PT RO SE SI SK SM TR

US-A1- 2003 088 695 US-A1- 2007 091 817

(30) Priority: **11.08.2008 US 87953 P**
05.12.2008 US 120232 P
06.08.2009 US 536637

- NTT DOCOMO: "Proposals for LTE-Advanced Technologies" 3GPP TSG-RAN WG1 #53BIS, R1-082575, [Online] 25 June 2008 (2008-06-25), pages 1-36, XP002558501 Retrieved from the Internet:
 URL:http://www.3gpp.org/ftp/tsg_ran/WG1_RL1/TSGR1_53b/Docs/ [retrieved on 2009-12-01]
- ERICSSON: "Carrier aggregation in LTE-Advanced" 3GPP MEETING , TSG-RAN WG1 #53BIS; [31882], WARSAW, POLAND, no. R1-082468, 30 June 2008 (2008-06-30), pages 1-6, XP002541667
- CATT: "Consideration on Technologies for LTE-Advanced" 3GPP DRAFT; R1-082569, 3RD GENERATION PARTNERSHIP PROJECT (3GPP), MOBILE COMPETENCE CENTRE ; 650, ROUTE DES LUCIOLES ; F-06921 SOPHIA-ANTIPOLIS CEDEX ; FRANCE, vol. RAN WG1, no. Warsaw, Poland; 20080625, 25 June 2008 (2008-06-25), XP050110829
- PHILIPS ET AL: "Discussion of Technologies for LTE-Advanced" 3GPP DRAFT; R1-082533, 3RD GENERATION PARTNERSHIP PROJECT (3GPP), MOBILE COMPETENCE CENTRE ; 650, ROUTE DES LUCIOLES ; F-06921 SOPHIA-ANTIPOLIS CEDEX ; FRANCE, vol. RAN WG1, no. Warsaw, Poland; 20080626, 26 June 2008 (2008-06-26), XP050110798

(43) Date of publication of application:
25.05.2011 Bulletin 2011/21

(60) Divisional application:
12162691.5 / 2 480 037

(73) Proprietor: **QUALCOMM Incorporated**
San Diego, CA 92121 (US)

- (72) Inventors:
- **DAMNJANOVIC, Jelena, M.**
San Diego
CA 92121 (US)
 - **MONTOJO, Juan**
San Diego
CA 92121 (US)
 - **SARKAR, Sandip**
San Diego
CA 92121 (US)

(74) Representative: **Tomkins & Co**
5 Dartmouth Road
Dublin 6 (IE)

(56) References cited:
EP-A1- 1 418 776 WO-A-2006/125149

Note: Within nine months of the publication of the mention of the grant of the European patent in the European Patent Bulletin, any person may give notice to the European Patent Office of opposition to that patent, in accordance with the Implementing Regulations. Notice of opposition shall not be deemed to have been filed until the opposition fee has been paid. (Art. 99(1) European Patent Convention).

EP 2 324 676 B1

- ERICSSON: "Considerations on Dual-Cell HSDPA Operation" 3GPP DRAFT; R1-081545, 3RD GENERATION PARTNERSHIP PROJECT (3GPP), MOBILE COMPETENCE CENTRE ; 650, ROUTE DES LUCIOLES ; F-06921 SOPHIA-ANTIPOLIS CEDEX ; FRANCE, vol. RAN WG1, no. Shenzhen, China; 20080327, 27 March 2008 (2008-03-27), XP050109958
- QUALCOMM EUROPE: "Notion of Anchor Carrier in LTE-A" 3GPP DRAFT; R1-090356, 3RD GENERATION PARTNERSHIP PROJECT (3GPP), MOBILE COMPETENCE CENTRE ; 650, ROUTE DES LUCIOLES ; F-06921 SOPHIA-ANTIPOLIS CEDEX ; FRANCE, no. Ljubljana; 20090108, 8 January 2009 (2009-01-08), XP050318262
- QUALCOMM EUROPE: "Carrier Aggregation in Heterogeneous Networks" 3GPP DRAFT; R1-090357, 3RD GENERATION PARTNERSHIP PROJECT (3GPP), MOBILE COMPETENCE CENTRE ; 650, ROUTE DES LUCIOLES ; F-06921 SOPHIA-ANTIPOLIS CEDEX ; FRANCE, no. Ljubljana; 20090108, 8 January 2009 (2009-01-08), XP050318263
- QUALCOMM EUROPE: "Multicarrier Control for LTE-Advanced" 3GPP DRAFT; R1-090359, 3RD GENERATION PARTNERSHIP PROJECT (3GPP), MOBILE COMPETENCE CENTRE ; 650, ROUTE DES LUCIOLES ; F-06921 SOPHIA-ANTIPOLIS CEDEX ; FRANCE, no. Ljubljana; 20090108, 8 January 2009 (2009-01-08), XP050318265
- ERICSSON: "Options for Inter-cell Interference Coordination (ICIC)" 3GPP DRAFT; R3-061199, 3RD GENERATION PARTNERSHIP PROJECT (3GPP), MOBILE COMPETENCE CENTRE ; 650, ROUTE DES LUCIOLES ; F-06921 SOPHIA-ANTIPOLIS CEDEX ; FRANCE, vol. RAN WG3, no. Tallinn; 20060823, 23 August 2006 (2006-08-23), XP050160110 [retrieved on 2006-08-23]
- QUALCOMM EUROPE: "Finalizing DL ICIC for Rel 8" 3GPP DRAFT; R1-081974, 3RD GENERATION PARTNERSHIP PROJECT (3GPP), MOBILE COMPETENCE CENTRE ; 650, ROUTE DES LUCIOLES ; F-06921 SOPHIA-ANTIPOLIS CEDEX ; FRANCE, vol. RAN WG1, no. Kansas City, USA; 20080514, 14 May 2008 (2008-05-14), XP050110324 [retrieved on 2008-05-14]
- HUAWEI: "Process of the Inter-cell RRM" 3GPP DRAFT; R3-060429, 3RD GENERATION PARTNERSHIP PROJECT (3GPP), MOBILE COMPETENCE CENTRE ; 650, ROUTE DES LUCIOLES ; F-06921 SOPHIA-ANTIPOLIS CEDEX ; FRANCE, vol. RAN WG3, no. Sophia Antipolis, France; 20060330, 30 March 2006 (2006-03-30), XP050159357 [retrieved on 2006-03-30]
- ALCATEL-LUCENT ET AL: "Support for Semi-Static Inter cell Interference Coordination" 3GPP DRAFT; R1-081874_SEMI-STATIC_INTER_COORD_OR_FREUS E_2, 3RD GENERATION PARTNERSHIP PROJECT (3GPP), MOBILE COMPETENCE CENTRE ; 650, ROUTE DES LUCIOLES ; F-06921 SOPHIA-ANTIPOLIS CEDEX ; FRANCE, vol. RAN WG1, no. Kansas City, USA; 20080514, 14 May 2008 (2008-05-14), XP050110242 [retrieved on 2008-05-14]

Description**BACKGROUND****Field**

[0001] The present disclosure relates generally to communication, and more specifically to techniques for multicarrier communication and for coordinating carrier transmission between nodes.

Background

[0002] The 3rd Generation Partnership Project (3GPP) Long Term Evolution (LTE) represents a major advance in cellular technology and is the next step forward in cellular 3G services as a natural evolution of Global system for mobile communications (GSM) and Universal Mobile Telecommunications System (UMTS). LTE provides for an uplink speed of up to 50 megabits per second (Mbps) and a downlink speed of up to 100 Mbps and brings many technical benefits to cellular networks. LTE is designed to meet carrier needs for high-speed data and media transport as well as high-capacity voice support well into the next decade. Bandwidth is scalable from 1.25 MHz to 20 MHz. This suits the needs of different network operators that have different bandwidth allocations, and also allows operators to provide different services based on spectrum. LTE is also expected to improve spectral efficiency in 3G networks, allowing carriers to provide more data and voice services over a given bandwidth. LTE encompasses high-speed data, multimedia unicast and multimedia broadcast services.

[0003] The LTE physical layer (PHY) is a highly efficient means of conveying both data and control information between an enhanced base station (eNodeB) and mobile user equipment (UE). The LTE PHY employs some advanced technologies that are new to cellular applications. These include Orthogonal Frequency Division Multiplexing (OFDM) and Multiple Input Multiple Output (MIMO) data transmission. In addition, the LTE PHY uses Orthogonal Frequency Division Multiple Access (OFDMA) on the downlink (DL) and Single Carrier - Frequency Division Multiple Access (SC-FDMA) on the uplink (UL). OFDMA allows data to be directed to or from multiple users on a subcarrier-by-subcarrier basis for a specified number of symbol periods.

[0004] Recently, LTE Advanced is an evolving mobile communication standard for providing 4G services. Being defined as 3G technology, LTE does not meet the requirements for 4G also called IMT Advanced as defined by the International Telecommunication Union such as peak data rates up to 1 Gbit/s. Besides the peak data rate, LTE Advanced also targets faster switching between power states and improved performance at the cell edge.

[0005] WO 2006/125149A2 describes a GSM network which supports multi-carrier operation on the downlink

and/or uplink.

[0006] US 2007/0091817A1 describes a method of transmitting channel quality information (CQI) to an access network.

SUMMARY

[0007] The following presents a simplified summary in order to provide a basic understanding of some aspects of the disclosed aspects. This summary is not an extensive overview and is intended to neither identify key or critical elements nor delineate the scope of such aspects. Instead, the scope of the present invention is defined by the appended claims. The purpose of this summary is to present some concepts of the described features in a simplified form as a prelude to the more detailed description that is presented later.

[0008] In one example, a method is provided for multiple carrier communication by employing a processor executing computer executable instructions stored on a computer readable storage medium to implement the following acts: An anchor carrier is received. A grant is detected carried on the anchor carrier assigning resources on another carrier. The assigned resources are utilized on the another carrier in accordance with the detected grant.

[0009] In another example, a computer program product is provided for multiple carrier communication. At least one computer readable storage medium stores computer executable instructions that when executed by at least one processor implement components: A first set of instructions causes a computer to receive an anchor carrier. A second set of instructions causes the computer to detect a grant carried on the anchor carrier assigning resources on another carrier. A third set of instructions causes the computer to utilize the assigned resources on the another carrier in accordance with the detected grant.

[0010] In an additional example, an apparatus is provided for multiple carrier communication. At least one computer readable storage medium stores computer executable instructions that when executed by the at least one processor implement components: Means are provided for receiving an anchor carrier. Means are provided for detecting a grant carried on the anchor carrier assigning resources on another carrier. Means are provided for utilizing the assigned resources on the another carrier in accordance with the detected grant.

[0011] In a further example, an apparatus is provided for multiple carrier communication by comprising a transmitter. A receiver receives an anchor carrier. A computing platform detects a grant carried on the anchor carrier assigning resources on another carrier and for utilizes the assigned resources via the transmitter or receiver on the another carrier in accordance with the detected grant.

[0012] In yet one example, a method is provided for multiple carrier communication by employing a processor executing computer executable instructions stored on a

computer readable storage medium to implement the following acts: Resources are scheduled for an anchor carrier and another carrier. A grant is transmitted on the anchor carrier assigning resources on the another carrier. Communication is performed with a recipient that utilizes the assigned resources on the another carrier in accordance with the grant.

[0013] In yet another example, a computer program product is provided for multiple carrier communication. At least one computer readable storage medium stores computer executable instructions that when executed by at least one processor implement components: A first set of instructions causes a computer to schedule resources for an anchor carrier and another carrier. A second set of instructions causes the computer to transmit a grant on the anchor carrier assigning resources on the another carrier. A third set of instructions causes the computer to communicate with a recipient that utilizes the assigned resources on the another carrier in accordance with the grant.

[0014] In yet an additional example, an apparatus is provided for multiple carrier communication. At least one computer readable storage medium stores computer executable instructions that when executed by the at least one processor implement components: Means are provided for scheduling resources for an anchor carrier and another carrier. Means are provided for transmitting a grant on the anchor carrier assigning resources on the another carrier. Means are provided for communicating with a recipient that utilizes the assigned resources on the another carrier in accordance with the grant.

[0015] In yet a further example, an apparatus is provided for multiple carrier communication by comprising receiver. A scheduler schedules resources for an anchor carrier and another carrier. A transmitter transmits a grant on the anchor carrier assigning resources on the another carrier. A receiver communicates with a recipient that utilizes the assigned resources on the another carrier in accordance with the grant.

[0016] In another additional example, a method is provided for coordinating carrier transmission between nodes by employing a processor executing computer executable instructions stored on a computer readable storage medium to implement the following acts: A first carrier is transmitted to provide wireless service to a first user equipment (UE) while a neighboring cell transmits a second carrier to provide wireless service to a second UE. Coordinating is performed with the neighboring cell so that a first and second UE receive respective carrier without jamming interference from the other carrier.

[0017] In yet another additional example, a computer program product is provided for coordinating carrier transmission between nodes. At least one computer readable storage medium stores computer executable instructions that when executed by at least one processor implement components: A first set of instructions causes a computer to transmit a first carrier to provide wireless service to a first user equipment (UE) while a neighboring

cell transmits a second carrier to provide wireless service to a second UE. A second set of instructions causes the computer to coordinate with the neighboring cell so that the first and second UE receive respective carrier without jamming interference from the other carrier.

[0018] In yet another further example, an apparatus is provided for coordinating carrier transmission between nodes. At least one computer readable storage medium stores computer executable instructions that when executed by the at least one processor implement components: Means are provided for transmitting a first carrier to provide wireless service to a first user equipment (UE) while a neighboring cell transmits a second carrier to provide wireless service to a second UE. Means are provided for coordinating with the neighboring cell so that the first and second UE receive respective carrier without jamming interference from the other carrier.

[0019] In yet a further additional example, an apparatus is provided for coordinating carrier transmission between nodes comprising a receiver. A transmitter transmits a first carrier to provide wireless service to a first user equipment (UE) while a neighboring cell transmits a second carrier to provide wireless service to a second UE. A scheduler coordinates with the neighboring cell so that the first and second UE receive respective carrier without jamming interference from the other carrier.

[0020] To the accomplishment of the foregoing and related ends, one or more aspects comprise the features hereinafter fully described and particularly pointed out in the claims. The following description and the annexed drawings set forth in detail certain illustrative aspects and are indicative of but a few of the various ways in which the principles of the aspects may be employed. Other advantages and novel features will become apparent from the following detailed description when considered in conjunction with the drawings and the disclosed aspects are intended to include all such aspects.

BRIEF DESCRIPTION OF THE DRAWINGS

[0021] The features, nature, and advantages of the present disclosure will become more apparent from the detailed description set forth below when taken in conjunction with the drawings in which like reference characters identify correspondingly throughout and wherein:

FIG. 1 depicts a block diagram of a wireless communication system in which multicarrier communication is coordinated and carrier transmission between nodes is performed to reduce interference.

FIG. 2 depicts a flow diagram for a methodology or sequence of operations for facilitating multiple carriers in a wireless communication system.

FIG. 3 depicts a block diagram of base stations serving and interfering with a population of terminals.

FIG. 4 depicts a block diagram of a multiple access wireless communication system.

FIG. 5 depicts a block diagram of a communication

system between a base station and a terminal.

FIG. 6 depicts a block diagram of a communication system to enable deployment of access point base stations within a network environment.

FIG. 7 illustrates various kinds of carriers differentiated within a communication system in accordance with an aspect;

FIG. 8 depicts a flow diagram of a methodology for facilitating communications in a wireless communication system by coordinating carrier selection and transmit power control between carriers.

FIG. 9 depicts a block diagram for a system such as user equipment containing logical groupings of electrical components for multicarrier wireless communication.

FIG. 10 depicts a block diagram for a system such as a network node containing logical groupings of electrical components for multicarrier wireless communication.

FIG. 11 depicts a block diagram for a system such as a network node containing logical groupings of electrical components for coordinating carrier selection and transmit power control between carriers.

FIG. 12 depicts a block diagram for an apparatus having means for multicarrier wireless communication.

FIG. 13 depicts a block diagram for an apparatus having means for multicarrier wireless communication.

FIG. 14 depicts a block diagram for an apparatus having means for coordinating carrier selection and transmit power control between carriers.

DETAILED DESCRIPTION

[0022] LTE-Advanced has provisions for multiple downlink (DL) and uplink (UL) carriers. Among the carriers, it is beneficial to have some special, by configuration designated carriers to provide synchronization, system information, paging, data and control for Rel-8 and/or LTE-A UEs. Thereby, overhead system information can be reduced. For instance, synchronization and paging for a certain cell are not provided on all carriers. In one aspect, an anchor carrier can serve as the legacy carrier for LTE terminals and provides support for new (Release 9/10) terminals for access, synchronization, broadcast, and new control region within the data region of the legacy terminals. Coordination between nodes for selecting anchor carriers that mitigate interference and for transmit power control for non-anchor carriers provide further network performance advantages.

[0023] Various aspects are now described with reference to the drawings. In the following description, for purposes of explanation, numerous specific details are set forth in order to provide a thorough understanding of one or more aspects. It may be evident, however, that the various aspects may be practiced without these specific details. In other instances, well-known structures and de-

vices are shown in block diagram form in order to facilitate describing these aspects.

[0024] With reference to **FIG. 1**, a communication system **100** enables user equipment (UE) **102** with advanced capabilities to acquire a subset of downlink (DL) carriers from a multiple carrier base station, depicted as an evolved Base Node (eNB) **104**. In particular, anchor carriers **106a**, **106b** are capable of scheduling downlink (DL) and uplink (UL) grants **108** for the UE **102** for other carriers **110a-110c**. In another aspect, the scheduling can encompass resources of one or more anchor carriers **106a**, **106b**.

[0025] It should be appreciated that a cluster of access points (APs) could be within a single node. For example, a cluster of APs could jointly serve UEs without orthogonal resources. Alternatively, a single AP can operate a plurality of nodes.

[0026] In one aspect, a multicarrier design for LTE-Advanced (e.g., Rel-9/Rel-10) supports an anchor carrier without restrictions on bandwidth dedication for each link. For example, the bandwidth dedication can be symmetrically the same for UL and DL. As another example, the bandwidth dedication can be asymmetric for the UL and DL as being dependent on the traffic demands for UL and DL. Similarly, carrier bandwidth can be uniform across carriers or different across carriers. UL/DL carrier pairing can be one to one with the same number of UL and DL carriers. Alternatively, UL/DL carrier pairing can be many to one or one to many with a different number of UL than DL carriers. UL carriers can be OFDMA (Orthogonal Frequency-Division Multiple Access) that provides flexibility for multiple carrier assignments to a UE. Alternatively, a SC-FDMA (Synchronous Code Division Multiple Access) based signal can be used for an anchor carrier. As another alternative, an OFDMA/SC-FDMA hybrid can support a layered environment with switching between those two.

[0027] As an overview of anchor carrier implementation, it would be advantageous and practical for a communication system **100** with collocated anchor and non-anchor carriers **106a-106b**, **110a-110c**. There may be several anchor carriers for different groups of carriers that carry system information, control, and perhaps data if sufficient resources. For example, an anchor carrier **106a** can support a group **112** that is a subset of carriers **106a**, **110a**, **110b**. Alternatively or in addition, an anchor carrier **106b** can support a group of carriers **106a**, **106b**, **110a-110c** that overlaps carriers **106a**, **110a**, **110b** supported by another carrier **106b**.

[0028] The transmission of downlink carriers **106a**, **106b**, **110a-110c** can be performed from a plurality of antennas (not shown). Alternatively or in addition, a plurality of eNB **104** can cooperate in communicating with the UE **102**. To that end, a scheduler **114** performs resource allocation coordinated over a backhaul network **116** (e.g., wired, wireless). Thereby, benefits can be realized such overhead reduction for eNB **104** that consolidate signaling on a subset of carriers, reducing required

searching for control across multiple carriers by UE **102**, and mapping of the Hybrid Automatic Repeat request (HARQ) feedback on an uplink.

[0029] Advantageously, some carriers **106b**, **110c** can provide support for backward compatible for legacy UEs **117** that are not capable of multiple carrier receiving by providing legacy DL and UL resource grants **118** on one carrier **110c** and its corresponding uplink **120**. This provides backward compatibility for an anchor carrier. In particular, primary synchronization signal (PSS) and secondary synchronization signal (SSS) can be provided on carriers for synchronization, MIB (Master Information Block) on PBCH (Physical Broadcast Channel) for system bandwidth, PHICH (Physical Hybrid ARQ Indicator Channel) configuration, and system frame number corresponding to the anchor carrier only. SIBs (System Information Block) can be provided on DL-SCH (Downlink Shared Channel). In one aspect, legacy UEs **118** can be redirected from the anchor to another DL carrier by an intra-cell inter-frequency handover message.

[0030] Further consider a special case where a group of carriers for which it is defined as an anchor is empty, it can become a regular (non-anchor) carrier wherein broadcast, control, and data is applicable only to that carrier.

[0031] With regard to conveying system information, in an illustrative aspect, additional SIBs on an anchor carrier can provide multicarrier information, such as carrier locations, carrier bandwidths, carrier designation (UL/DL), carrier pairing, other anchor (UL and DL) carriers, and new control regions. In one aspect, additional SIBs can be transparent to the legacy UEs.

[0032] Non-anchor carriers in an exemplary aspect may not need to provide backward compatibility that is instead provided by the anchor carrier used by a new class of UEs.

[0033] With regard to DL grant, legacy UE thus receives a DL grant on the same anchor carrier that assigns resources on the same carrier. A UE with advanced capabilities (e.g., Rel-9/10) can receive a DL grant from an anchor carrier for DL resources on another DL carrier. In one aspect, the anchor carrier supports an assigned group of carriers. In another aspect, each anchor carrier can transmit a DL grant on multiple carriers including other anchor carrier or non-anchor carriers also assigned by another DL anchor carrier. In a further aspect, a DL non-anchor carrier can transmit DL grants that assign DL resources for that carrier only similarly to that performed for legacy UEs.

[0034] With regard to UL Grant, a legacy UE receives an UL grant on the anchor carrier that assigns resources on the UL carrier paired with the anchor carrier. An advanced UE (e.g., Rel-9/10) receives an UL grant on the anchor carrier that assigns UL resources on the other UL carriers for which it is defined as an anchor carrier (i.e., grouped or not grouped). In one aspect, UL carriers are paired with the DL carriers for which it is defined as an anchor carrier. In one aspect, UL grants on a DL carrier

that is not an anchor carrier can assign only the resources for the UL carrier paired with it similar to that used for legacy UEs.

[0035] With regard to HARQ, in one aspect the eNB transmits UL HARQ feedback on a DL carrier that sent the UL grant. For multi-carrier grants, in another aspect the HARQ feedbacks for different UL carriers can be sent on the anchor carrier where the multi-carrier grant was sent. Resource mapping can adjust such that ACKs (acknowledgements) for different carriers are distinguished. DL HARQ feedback on UL can come on the UL carrier paired with the DL carrier where the grant was sent. For multicarrier grants, the HARQ feedbacks for different DL carriers can be sent on the UL paired with the anchor carrier, where the grant was sent. Resource mapping is such that ACKs for different carriers are distinguished. In one aspect, a legacy UL is implicitly achieved by using one anchor carrier to convey all DL assignments, such as being based on the first CCE (Control Channel Element) on DCI (Downlink Control Information) on the PDCCH (Physical Downlink Control Channel).

[0036] Regarding CQI (Channel Quality Indicator) Feedback on UL, in one aspect CQI feedback for multiple DL carriers can be conveyed on the anchor UL carrier. In an illustrative implementation, an anchor UL carrier is defined in additional SIBs (system information blocks) or by RRC (Radio Resource Control) signaling (per UE). In an exemplary aspect, UL carrier is paired with the DL anchor carrier that enables implicit signaling.

[0037] The scheduler **114** can advantageously unilaterally assign resources on a carrier that is not subject to interference from a non-cooperating cell **130**. The scheduler **116** can coordinate by backhaul communication **132** with a cooperating cell **134** to use different anchor carriers **136**, **138**. The scheduler **116** can coordinate transmit power adjustment on non-anchor carriers **140**, **142** so that they can be used for single carrier service or to avoid interfering with a UE **144** serviced by the cooperating cell **134**.

[0038] In **FIG. 2**, a methodology or sequence of operations **200** is provided for multiple carrier communication. In block **202**, UE receives an anchor carrier. The UE detects common system information or dedicated information on the anchor carrier (block **204**). The UE acquires the another carrier by using the common system information or dedicated information (block **206**). In one aspect, the UE detects system information blocks on the anchor carrier for utilizing the another carrier comprising carrier location, carrier bandwidth, carrier uplink or downlink designation, carrier pairing, and a new control region (block **208**). In another aspect, the UE detects a grant carried on the anchor carrier that assigns resources on another carrier such as a non-anchor (block **210**). The assignment can be grouped exclusively or overlapping where certain anchor carriers can both assign resources with regard to a particular carrier (block **212**). UE utilizes the assigned resources on the another carrier in accordance with the detected grant (block **214**). UE receives

acknowledgement of receipt by the node of the uplink carrier transmission on the anchor carrier that sent the uplink grant (block 216).

[0039] In some instances, UE can receive a non-anchor carrier that was previously received as the anchor carrier subsequent to the another carrier no longer requiring assignment of resources (block 218).

[0040] In another instance, a legacy UE can initiate single carrier communication by synchronizing to one of the carriers (anchor or non-anchor). For example, the UE can perform synchronizing to primary and secondary synchronization signals of the anchor carrier, detecting master information block on a Physical Broadcast Channel informing system bandwidth, Physical Hybrid Automatic Repeat Request Indicator Channel (PHICH) configuration, system frame number; and detecting system information blocks on downlink shared channel (DL-SCH) for resources on the anchor carrier (block 220). In lieu of multicarrier operation, the node can direct a single carrier UE with a redirection message to another carrier by intra-cell inter-frequency handover (block 222).

[0041] Multicarrier operation can advantageously address feedback. For instance, UE can receive acknowledgement of receipt of each of the uplink carrier transmissions on the anchor carrier that sent the uplink grant (block 224). Insofar as UE may have transmitted on multiple uplinks, UE accesses a mapping of acknowledgements to multiple carriers (block 226) and interprets the acknowledgement for each uplink carrier transmission utilizing the mapping (block 228). UE retransmits the uplink carrier transmission determined to have been unsuccessfully transmitted (block 230).

[0042] UE can further transmit Channel Quality Indicator (CQI) feedback for multiple downlink carriers on an uplink anchor carrier (block 232), such as by detecting an additional system information block on the anchor carrier (block 234) or by detecting resource radio control (RRC) signaling (block 236).

[0043] When UE reports CQI feedback conveying interference jamming receipt of a carrier (block 238), UE receives a grant assigning resources on a carrier not jammed by the interference (block 240). Freeing up of an unjammed carrier can be a result of the node coordinating a transmit power control change by either a serving node or an interfering node for multiple carrier reuse (block 242). In one aspect, a multicarrier capable UE can use single carrier communication by a non-anchor carrier that is made available by coordination (block 244).

[0044] In the example shown in FIG. 3, base stations 310a, 310b and 310c may be macro base stations for macro cells 302a, 302b and 302c, respectively. Base station 310x may be a pico base station for a pico cell 302x communicating with terminal 320x. Base station 310y may be a femto base station for a femto cell 302y communicating with terminal 320y. Although not shown in FIG. 3 for simplicity, the macro cells may overlap at the edges. The pico and femto cells may be located within the macro cells (as shown in FIG. 3) or may overlap with

macro cells and/or other cells.

[0045] Wireless network 300 may also include relay stations, e.g., a relay station 310z that communicates with terminal 320z. A relay station is a station that receives a transmission of data and/or other information from an upstream station and sends a transmission of the data and/or other information to a downstream station. The upstream station may be a base station, another relay station, or a terminal. The downstream station may be a terminal, another relay station, or a base station. A relay station may also be a terminal that relays transmissions for other terminals. A relay station may transmit and/or receive low reuse preambles. For example, a relay station may transmit a low reuse preamble in similar manner as a pico base station and may receive low reuse preambles in similar manner as a terminal.

[0046] A network controller 330 may couple to a set of base stations and provide coordination and control for these base stations. Network controller 330 may be a single network entity or a collection of network entities. Network controller 330 may communicate with base stations 310 via a backhaul. Backhaul network communication 334 can facilitate point-to-point communication between base stations 310a-310c employing such a distributed architecture. Base stations 310a-310c may also communicate with one another, e.g., directly or indirectly via wireless or wireline backhaul.

[0047] Wireless network 300 may be a homogeneous network that includes only macro base stations (not shown in FIG. 3). Wireless network 300 may also be a heterogeneous network that includes base stations of different types, e.g., macro base stations, pico base stations, home base stations, relay stations, etc. These different types of base stations may have different transmit power levels, different coverage areas, and different impact on interference in wireless network 300. For example, macro base stations may have a high transmit power level (e.g., 20 Watts) whereas pico and femto base stations may have a low transmit power level (e.g., 3 Watt). The techniques described herein may be used for homogeneous and heterogeneous networks.

[0048] Terminals 320 may be dispersed throughout wireless network 300, and each terminal may be stationary or mobile. A terminal may also be referred to as an access terminal (AT), a mobile station (MS), user equipment (UE), a subscriber unit, a station, etc. A terminal may be a cellular phone, a personal digital assistant (PDA), a wireless modem, a wireless communication device, a handheld device, a laptop computer, a cordless phone, a wireless local loop (WLL) station, etc. A terminal may communicate with a base station via the downlink and uplink. The downlink (or forward link) refers to the communication link from the base station to the terminal, and the uplink (or reverse link) refers to the communication link from the terminal to the base station.

[0049] A terminal may be able to communicate with macro base stations, pico base stations, femto base stations, and/or other types of base stations. In FIG. 3, a

solid line with double arrows indicates desired transmissions between a terminal and a serving base station, which is a base station designated to serve the terminal on the downlink and/or uplink. A dashed line with double arrows indicates interfering transmissions between a terminal and a base station. An interfering base station is a base station causing interference to a terminal on the downlink and/or observing interference from the terminal on the uplink.

[0050] Wireless network 300 may support synchronous or asynchronous operation. For synchronous operation, the base stations may have the same frame timing, and transmissions from different base stations may be aligned in time. For asynchronous operation, the base stations may have different frame timing, and transmissions from different base stations may not be aligned in time. Asynchronous operation may be more common for pico and femto base stations, which may be deployed indoors and may not have access to a synchronizing source such as Global Positioning System (GPS).

[0051] In one aspect, to improve system capacity, the coverage area 302a, 302b, or 302c corresponding to a respective base station 310a-310c can be partitioned into multiple smaller areas (e.g., areas 304a, 304b, and 304c). Each of the smaller areas 304a, 304b, and 304c can be served by a respective base transceiver subsystem (BTS, not shown). As used herein and generally in the art, the term "sector" can refer to a BTS and/or its coverage area depending on the context in which the term is used. In one example, sectors 304a, 304b, 304c in a cell 302a, 302b, 302c can be formed by groups of antennas (not shown) at base station 310, where each group of antennas is responsible for communication with terminals 320 in a portion of the cell 302a, 302b, or 302c. For example, a base station 310 serving cell 302a can have a first antenna group corresponding to sector 304a, a second antenna group corresponding to sector 304b, and a third antenna group corresponding to sector 304c. However, it should be appreciated that the various aspects disclosed herein can be used in a system having sectorized and/or unsectorized cells. Further, it should be appreciated that all suitable wireless communication networks having any number of sectorized and/or unsectorized cells are intended to fall within the scope of the hereto appended claims. For simplicity, the term "base station" as used herein can refer both to a station that serves a sector as well as a station that serves a cell. It should be appreciated that as used herein, a downlink sector in a disjoint link scenario is a neighbor sector. While the following description generally relates to a system in which each terminal communicates with one serving access point for simplicity, it should be appreciated that terminals can communicate with any number of serving access points.

[0052] Referring to FIG. 4, a multiple access wireless communication system according to one embodiment is illustrated. An access point (AP) 400 includes multiple antenna groups, one including 404 and 406, another in-

cluding 408 and 410, and an additional including 412 and 414. In FIG. 4, only two antennas are shown for each antenna group, however, more or fewer antennas may be utilized for each antenna group. Access terminal (AT) 416 is in communication with antennas 412 and 414, where antennas 412 and 414 transmit information to access terminal 416 over forward link 420 and receive information from access terminal 416 over reverse link 418. Access terminal 422 is in communication with antennas 406 and 408, where antennas 406 and 408 transmit information to access terminal 422 over forward link 426 and receive information from access terminal 422 over reverse link 424. In a FDD system, communication links 418, 420, 424 and 426 may use different frequency for communication. For example, forward link 420 may use a different frequency than that used by reverse link 418.

[0053] Each group of antennas and/or the area in which they are designed to communicate is often referred to as a sector of the access point. In the aspect, antenna groups each are designed to communicate to access terminals in a sector, of the areas covered by access point 400.

[0054] In communication over forward links 420 and 426, the transmitting antennas of access point 400 utilize beamforming in order to improve the signal-to-noise ratio of forward links for the different access terminals 416 and 422. Also, an access point using beamforming to transmit to access terminals scattered randomly through its coverage causes less interference to access terminals in neighboring cells than an access point transmitting through a single antenna to all its access terminals.

[0055] An access point may be a fixed station used for communicating with the terminals and may also be referred to as an access point, a Node B, or some other terminology. An access terminal may also be called an access terminal, user equipment (UE), a wireless communication device, terminal, access terminal or some other terminology.

[0056] FIG. 5 shows a block diagram of a design of a communication system 500 between a base station 502 and a terminal 504, which may be one of the base stations and one of the terminals in FIG. 1. Base station 502 may be equipped with TX antennas 534a through 534t, and terminal 504 may be equipped with RX antennas 552a through 552r, where in general $T \geq 1$ and $R \geq 1$.

[0057] At base station 502, a transmit processor 520 may receive traffic data from a data source 512 and messages from a controller/processor 540. Transmit processor 520 may process (e.g., encode, interleave, and modulate) the traffic data and messages and provide data symbols and control symbols, respectively. Transmit processor 520 may also generate pilot symbols and data symbols for a low reuse preamble and pilot symbols for other pilots and/or reference signals. A transmit (TX) multiple-input multiple-output (MIMO) processor 530 may perform spatial processing (e.g., precoding) on the data symbols, the control symbols, and/or the pilot symbols, if applicable, and may provide T output symbol streams

to T modulators (MODs) **532a** through **532t**. Each modulator **532** may process a respective output symbol stream (e.g., for OFDM, SC-FDM, etc.) to obtain an output sample stream. Each modulator **532** may further process (e.g., convert to analog, amplify, filter, and up-convert) the output sample stream to obtain a downlink signal. T downlink signals from modulators **532a** through **532t** may be transmitted via T antennas **534a** through **534t**, respectively.

[0058] At terminal **504**, antennas **552a** through **552r** may receive the downlink signals from base station **502** and may provide received signals to demodulators (DEMODs) **554a** through **554r**, respectively. Each demodulator **554** may condition (e.g., filter, amplify, downconvert, and digitize) a respective received signal to obtain input samples. Each demodulator **554** may further process the input samples (e.g., for OFDM, SC-FDM, etc.) to obtain received symbols. A MIMO detector **556** may obtain received symbols from all R demodulators **554a** through **554r**, perform MIMO detection on the received symbols if applicable, and provide detected symbols. A receive processor **558** may process (e.g., demodulate, deinterleave, and decode) the detected symbols, provide decoded traffic data for terminal **504** to a data sink **560**, and provide decoded messages to a controller/processor **580**. A low reuse preamble (LRP) processor **584** may detect for low reuse preambles from base stations and provide information for detected base stations or cells to controller/processor **580**.

[0059] On the uplink, at terminal **504**, a transmit processor **564** may receive and process traffic data from a data source **562** and messages from controller/processor **580**. The symbols from transmit processor **564** may be precoded by a TX MIMO processor **568** if applicable, further processed by modulators **554a** through **554r**, and transmitted to base station **502**. At base station **502**, the uplink signals from terminal **504** may be received by antennas **534**, processed by demodulators **532**, detected by a MIMO detector **536** if applicable, and further processed by a receive data processor **538** to obtain the decoded packets and messages transmitted by terminal **504** for providing to a data sink **539**.

[0060] Controllers/processors **540** and **580** may direct the operation at base station **502** and terminal **504**, respectively. Processor **540** and/or other processors and modules at base station **502** may perform or direct processes for the techniques described herein. Processor **584** and/or other processors and modules at terminal **504** may perform or direct processes for the techniques described herein. Memories **542** and **582** may store data and program codes for base station **502** and terminal **504**, respectively. A scheduler **544** may schedule terminals for data transmission on the downlink and/or uplink and may provide resource grants for the scheduled terminals.

[0061] FIG. 6 illustrates an exemplary communication system to enable deployment of access point base stations within a network environment. As shown in FIG. 6,

the system **600** includes multiple access point base stations or Home Node B units (HNBs), such as, for example, HNBs **610**, each being installed in a corresponding small scale network environment, such as, for example, in one or more user residences **630**, and being configured to serve associated, as well as alien, user equipment (UE) **620**. Each HNB **610** is further coupled to the Internet **640** and a mobile operator core network **650** via a DSL router (not shown) or, alternatively, a cable modem (not shown), a wireless link, or other Internet connectivity means.

[0062] Although aspects described herein use 3GPP terminology, it is to be understood that the embodiments may be applied to 3GPP (Re199, Re15, Re16, Re17) technology, as well as 3GPP2 (1xRTT, 1xEV-DO Re10, RevA, RevB) technology and other known and related technologies. In such embodiments described herein, the owner of the HNB **610** subscribes to mobile service, such as, for example, 3G mobile service, offered through the mobile operator core network **650**, and the UE **620** is capable to operate both in macro cellular environment and in residential small scale network environment.

[0063] MULTI-CARRIER COMMUNICATION WITH ANCHOR AND NON-ANCHOR CARRIERS. In accordance with different aspects, various types of carriers are provided for facilitating mobile communications within different types of cells in a manner that avoids replication of information and hence reduces system overhead. The various carriers can comprise, anchor carriers, non-anchor carriers, segments etc. Anchor carriers can facilitate communications for UEs in both connected mode wherein a UE maintains an active connection with a base station and idle mode wherein a UE has no active connection with the base station. Such idle mode users may only be monitoring the system and are ready to receive pages or access requests as calls generate. Hence, the anchor carriers are by configuration, carriers that are designated to provide synchronization, system information, paging, data and control for Release 8 and/or LTE-A (LTE Advanced) UEs. While there can be several anchor carriers for a given cell, every cell needs at least one anchor carrier. Non-anchor carriers support only UEs in connected mode and hence do not transmit System Information (SI), etc., and hence cannot page UEs. In accordance with various aspects, a communication system with multicarrier deployment is disclosed wherein different types of carriers such as anchor or non-anchor carriers have different capabilities associated therewith to service UEs in different states of connectivity.

[0064] It should be appreciated with the benefit of the present disclosure that various kinds of carriers can be differentiated within a communication system in accordance with an aspect. As mentioned supra, carriers can be primarily configured to be anchor or non-anchor carriers based on the information associated therewith. Anchor carriers can be further differentiated as backward compatible single carrier anchor, backward compatible multicarrier anchor, and Rel-8 non-backward compatible

anchor. In addition, other non-anchor carriers can include Rel-8 non-backward compatible carriers. Segments are non-carriers that cannot independently support a UE for communication but provide communication facilities in conjunction with an anchor/non-anchor carrier as will be detailed infra.

[0065] Another aspect is associated with differentiation among carriers such that different carriers offer different services to user conforming to different releases of the LTE standards. Backward compatible single carrier anchor carrier provides service to different kinds of UEs that include UEs that have upgraded to Rel-8 of LTE and UEs that have yet to upgrade to Rel-8. In addition, a single carrier anchor carrier comprises information associated with only one anchor carrier. For example, it can carry PSS/SSS (primary/secondary synchronization sequences), Rel-8 system information (SI), paging etc. in accordance with various aspects. Hence, a backward compatible single carrier anchor is a carrier comprising information associated with only one anchor carrier and which provides camping and access for users having different versions of LTE standards. In accordance with another aspect, the backward compatible single carrier anchor carrier can comprise information that points to a multicarrier anchor carrier. This pointer can be used to obtain SI associated with the relevant multicarrier anchor carrier. In different aspects, the pointer can only be used by UEs subscribing to a specified version of the LTE standard. For example, the pointer can be intended only for the LTE-A UEs and can be transparent to Rel-8 UEs.

[0066] The second type of anchor carrier is the backward compatible multicarrier anchor. As mentioned supra, a backward compatible carrier supports users having different versions of the LTE standard. In accordance with a detailed aspect, the backward compatible multicarrier anchor can provide PSS/SSS, Rel-8 system information, paging etc. for different UEs. In a further aspect, it can carry information associated with different carriers in additional SIBs (system information blocks) that provide the multicarrier information for a cell. Multicarrier information such as carrier locations, carrier bandwidths, carrier designation (UL/DL), carrier pairing, other anchor carrier, and new control regions can all be delivered to various UEs subscribing to different LTE standards in both connected and idle modes. Hence, it is configured to provide information about other carriers so that users can monitor other carriers based on the information obtained from a given multicarrier anchor. Rel-8 non-backward compatible anchor is a third type of anchor carrier that supports only users who subscribe to Rel-8 of LTE. Hence, it supports UEs subscribing to LTE Rel-8 in a RRC connected or RRC idle mode by transmitting SI, synchronization, paging and other services. However, Rel-8 non-backward compatible anchor does not support UEs that have not upgraded to this version of LTE. Additionally, Rel-8 non-backward compatible anchor bears multicarrier system information associated with other carriers that can be monitored by a UE in order to track

other carriers that provide service within a given cell.

[0067] Rel-8 non-backward compatible carrier is a stand-alone carrier used only for LTE-A UEs in RRC connected state. Hence, it can be designated as a non-anchor carrier that does not permit UEs to camp on it. As a result, SI updates are provided on an event-driven basis as multi-cast or in-band, for example, when the SI changes and users need to be updated with such changes. It carries new synchronization signal to keep the LTE-A UE synchronization in RRC connected state. Synchronization signals can be omitted, provided that the synchronization is possible on at least one other carrier of the same cell an LTE-A UE is configured for.

[0068] In FIG. 7, a downlink (DL) carrier **700** is depicted as providing a PDCCH (Packet Data Control Channel) **702** that facilitates communication in accordance with another aspect. The transmission comprises a Carrier **0 704** and two segments, Segment **1 706** and Segment **2 708**. As mentioned supra, a carrier **700** can independently support a UE connection to a base station. A segment is an extension of a carrier that comprises additional signaling resources that support a UE connection with a base station in conjunction with a carrier. Hence, a segment is always linked to a carrier **and** cannot independently support UE communications with a base station. In an aspect, the segment is configured as a pure data extension devoid of synchronization signals, SI (System Information) or paging capability. Thus, segments are a further refinement of the concept of a non-anchor carrier which does not provide paging capability since it serves only UEs in RRC (Radio Resource Control) connected mode. Alternatively, the segments can provide synchronization and control aspects.

[0069] In the illustrative depiction, Carrier **0 704** can independently support a UE communications but has additional resources in the form of two segments - Segment **1 706** and Segment **2 708** associated therewith. Each of these segments **706, 708** cannot independently support UE connections but facilitate communications in association with a single Carrier **0 704**. Carrier **0 704** can be an anchor or a non-anchor carrier in accordance with different aspects. Thus, while a UE monitoring a carrier is capable of facilitating communications, a UE cannot receive service if it is monitoring only a segment.

[0070] An anchor carrier can therefore be used to reduce system overhead as it mitigates replication of information. This is because, general purpose information can be concentrated on a small subset of carriers while other carriers can support connected mode users without replicating redundant information. Segments within a communication system can further reduce replicating information by carrying only a data and a dedicated control channel but none of the steady state channels needed to support connected mode users. Additionally, such differentiation within carriers facilitates better synchronization, camping and access in a heterogeneous environment as further detailed infra. Interference coordination can provide for at least one detectable (accessible) an-

chor carrier.

[0071] With further reference to FIG. 7, a heterogeneous system 720 that can utilize multiple carriers is depicted as comprising a macro cell 722, a pico cell 724 and a CSG (closed subscriber group) cell 726. The latter can comprise a femto-cell. In accordance with an aspect, a macro base station 728 can be transmitting with high power while a pico base station 730 and a femto base station 732 can be transmitting with lower power. In this system, service can be extended into the pico cell 724 by reducing the amount of power the macro base station 728 transmits on certain carriers. Hence, the macro cell 722 can designate certain carriers as anchor carriers and certain carriers as non-anchor carriers. The macro cell 722 can transmit anchor carriers at normal power and non-anchor carriers at lower power that can match the pico base station 730. In the figure, Carrier 1 is an anchor carrier for the macro cell 722 and hence is transmitted at normal power while Carrier 2 is a non-anchor carrier for the macro cell 722 and hence can be transmitted at lower power, depicted as an inner limit 734 that falls short of the pico cell 724 and CSG cell 726. Pico cell 724 can be configured to provide Carrier 1 and Carrier 2 as anchor carriers. CSG cell 726 is a cell that only admits certain authorized users to connect to it and therefore users who are not authorized to access the CSG resources will not be able to connect via the CSG 732. A femto cell wherein UEs communicate with each other via an IP network is an example of a CSG cell. As CSG 732 does not permit all users to access its resources, it can cause interference within the heterogeneous environment. That is, an unsubscribing UE can be jammed by the CSG 732 as a relatively strong carrier but have to use a subjectively lower power cell for service. Therefore, to protect the macro and pico base stations 722, 724 from such interference, the CSG cell 726 can be designated to transmit only on carrier 2 and not on Carrier 1. This mitigates interference on Carrier 1 thereby facilitating user equipment to connect via a nearest macro/pico BS 728, 730.

[0072] As depicted, Carrier 2 is an anchor carrier within the pico cell 724. Therefore, Pico cell served UEs 0 and 1 738, 740 can be scheduled on Pico anchor carrier 2 as depicted respectively at 742, 744. In addition, UE 0 738 can be scheduled by the pico base station 730 on carrier 1 as depicted at 746 as the interference from the Macro BS 728 seen by that UE 0 738 on carrier 1 is very weak. However, UE 1 740 experiences stronger interference from the Macro BS 728 on carrier 1 as depicted at 748, and therefore will only be scheduled by the Pico BS 730 on Carrier 2 as depicted at 744. UE 2 752 and UE 3 754 are served by the Macro BS 728 and hence are scheduled on Macro anchor Carrier 1 as depicted respectively at 756, 758. In addition, UE 2 752 can be scheduled by Macro BS 728 on Carrier 2 as depicted at 760 since it is close enough to the Macro BS 728 and falls within the coverage range of Carrier 2 as depicted at 734 unlike UE 3 744 which lies outside the coverage range 734 of Carrier 2 due to the lower transmit power on this particular

carrier from the Macro BS 728.

[0073] UE 4 764 and UE 5 766 are within the coverage range of the CSG cell 726 but are not permitted to access its resources. However, these UEs 764, 766 have access to Macro anchor Carrier 1. Therefore, while UE 4 764 is within the coverage area of both Macro and Pico cells 722, 724, it will be connected on Carrier 1 to Macro cell 722 as the signal from the Macro cell 722 is stronger. Similarly while UE 5 766 is within the coverage area of both Macro and Pico cell 724, 726 on Carrier 1, it will be connected on this carrier to Pico cell 724 as depicted 767 as the signal from the Pico cell 724 is stronger. UE 6 768 has permission to access the CSG cell 726 and hence will be connected to it on its anchor Carrier 2 as depicted at 770.

[0074] FIG. 8 illustrates a methodology 800 of facilitating communications in a wireless communication system in accordance with an aspect. The method begins at 802 wherein one or more anchor carriers are initially configured to carry SI to UEs within a cell on a periodic basis. As mentioned supra, such anchor carriers can facilitate communications for UEs which are either in a RRC idle mode or for those UEs in a connected mode. At 804, one or more non-anchor carriers are also configured to carry SI on an event-driven basis. For example, if the SI changes, then non-anchor carriers can be employed to transmit such changes to UEs based on a need to update the UEs. However, unlike anchor carriers, non-anchor carriers can facilitate communications for UEs which are only in a connected mode and cannot facilitate communications for UEs in an idle mode. This is because, the carriers are configured into anchor and non-anchor carriers in a manner that reduces replication of information transmitted in a wireless communication system whereby only anchor carriers are able to provide paging capabilities. Therefore, in order to facilitate communications, each base station has at least one anchor carrier associated therewith. At 806, the anchor carriers are transmitted at a power level that is normally used by the base stations for its transmission. At 808, the non-anchor carriers are transmitted at power levels lower than the normal power levels and the method terminates at the end block. This differentiation in transmission power levels associated with anchor/non-anchor carriers facilitates better interference coordination. Reducing power levels on certain carriers, such as non-anchor carriers, enables deeper penetration of certain other carriers such as anchor carriers. This mitigates interference for these anchor carriers thereby providing for at least one detectable (accessible) anchor carrier

[0075] With reference to FIG. 9, illustrated is a system 900 for multiple carrier communication. For example, system 900 can reside at least partially within user equipment, mobile device, or access terminal. It is to be appreciated that system 900 is represented as including functional blocks, which can be functional blocks that represent functions implemented by a computing platform, processor, software, or combination thereof (e.g.,

firmware). System **900** includes a logical grouping **902** of electrical components that can act in conjunction. For instance, logical grouping **902** can include an electrical component for receiving an anchor carrier **904**. Moreover, logical grouping **902** can include an electrical component for detecting a grant carried on the anchor carrier that assigns resources on another carrier **906**. Further, logical grouping **902** can include an electrical component for utilizing the assigned resources on the another carrier in accordance with the detected grant **908**. Additionally, system **900** can include a memory **920** that retains instructions for executing functions associated with electrical components **904 - 908**. While shown as being external to memory **920**, it is to be understood that one or more of electrical components **904 - 908** can exist within memory **920**.

[0076] With reference to **FIG. 10**, illustrated is a system **1000** for multiple carrier communication. For example, system **1000** can reside at least partially within a base station. It is to be appreciated that system **1000** is represented as including functional blocks, which can be functional blocks that represent functions implemented by a computing platform, processor, software, or combination thereof (e.g., firmware). System **1000** includes a logical grouping **1002** of electrical components that can act in conjunction. For instance, logical grouping **1002** can include an electrical component for scheduling resources for an anchor carrier and another carrier **1004**. Moreover, logical grouping **1002** can include an electrical component for transmitting a grant on the anchor carrier that assigns resources on the another carrier **1006**. Further, logical grouping **1002** can include an electrical component for communicating with a recipient that utilizes the assigned resources on the another carrier in accordance with the grant **1008**. Additionally, system **1000** can include a memory **1020** that retains instructions for executing functions associated with electrical components **1004 - 1008**. While shown as being external to memory **1020**, it is to be understood that one or more of electrical components **1004 - 1008** can exist within memory **1020**.

[0077] With reference to **FIG. 11**, illustrated is a system **1100** for coordinating carrier transmission between nodes. For example, system **1100** can reside at least partially within a base station. It is to be appreciated that system **1100** is represented as including functional blocks, which can be functional blocks that represent functions implemented by a computing platform, processor, software, or combination thereof (e.g., firmware). System **1100** includes a logical grouping **1102** of electrical components that can act in conjunction. For instance, logical grouping **1102** can include an electrical component for transmitting a first carrier to provide wireless service to a first user equipment (UE) while a neighboring cell transmits a second carrier to provide wireless service to a second UE **1104**. Moreover, logical grouping **1102** can include an electrical component for coordinating with the neighboring cell so that the first and second UE receive respective carrier without jamming interference

from the other carrier **1106**. Additionally, system **1100** can include a memory **1120** that retains instructions for executing functions associated with electrical components **1104 - 1106**. While shown as being external to memory **1120**, it is to be understood that one or more of electrical components **1104 - 1106** can exist within memory **1120**.

[0078] With reference to **FIG. 12**, an apparatus **1200** is provided for multiple carrier communication. Means **1204** are provided for receiving an anchor carrier. Means **1206** are provided for detecting a grant carried on the anchor carrier that assigns resources on another carrier. Means **1208** are provided for utilizing the assigned resources on the another carrier in accordance with the detected grant.

[0079] With reference to **FIG. 13**, an apparatus **1300** is provided for multiple carrier communication. Means **1304** are provided for scheduling resources for an anchor carrier and another carrier. Means **1306** are provided for transmitting a grant on the anchor carrier that assigns resources on the another carrier. Means **1308** are provided for communicating with a recipient that utilizes the assigned resources on the another carrier in accordance with the grant.

[0080] With reference to **FIG. 14**, an apparatus **1400** is provided for coordinating carrier transmission between nodes. Means **1404** are provided for transmitting a first carrier to provide wireless service to a first user equipment (UE) while a neighboring cell transmits a second carrier to provide wireless service to a second UE. Means **1406** are provided for coordinating with the neighboring cell so that the first and second UE receive respective carrier without jamming interference from the other carrier.

[0081] Those of skill in the art would understand that information and signals may be represented using any of a variety of different technologies and techniques. For example, data, instructions, commands, information, signals, bits, symbols, and chips that may be referenced throughout the above description may be represented by voltages, currents, electromagnetic waves, magnetic fields or particles, optical fields or particles, or any combination thereof.

[0082] Those of skill would further appreciate that the various illustrative logical blocks, modules, circuits, and algorithm steps described in connection with the embodiments disclosed herein may be implemented as electronic hardware, computer software, or combinations of both. To clearly illustrate this interchangeability of hardware and software, various illustrative components, blocks, modules, circuits, and steps have been described above generally in terms of their functionality. Whether such functionality is implemented as hardware or software depends upon the particular application and design constraints imposed on the overall system. Skilled artisans may implement the described functionality in varying ways for each particular application, but such implementation decisions should not be interpreted as causing

a departure from the scope of the present disclosure.

[0083] As used in this application, the terms "component", "module", "system", and the like are intended to refer to a computer-related entity, either hardware, a combination of hardware and software, software, or software in execution. For example, a component may be, but is not limited to being, a process running on a processor, a processor, an object, an executable, a thread of execution, a program, and/or a computer. By way of illustration, both an application running on a server and the server can be a component. One or more components may reside within a process and/or thread of execution and a component may be localized on one computer and/or distributed between two or more computers.

[0084] The word "exemplary" is used herein to mean serving as an example, instance, or illustration. Any aspect or design described herein as "exemplary" is not necessarily to be construed as preferred or advantageous over other aspects or designs.

[0085] Various aspects will be presented in terms of systems that may include a number of components, modules, and the like. It is to be understood and appreciated that the various systems may include additional components, modules, etc. and/or may not include all of the components, modules, etc. discussed in connection with the figures. A combination of these approaches may also be used. The various aspects disclosed herein can be performed on electrical devices including devices that utilize touch screen display technologies and/or mouse-and-keyboard type interfaces. Examples of such devices include computers (desktop and mobile), smart phones, personal digital assistants (PDAs), and other electronic devices both wired and wireless.

[0086] In addition, the various illustrative logical blocks, modules, and circuits described in connection with the embodiments disclosed herein may be implemented or performed with a general purpose processor, a digital signal processor (DSP), an application specific integrated circuit (ASIC), a field programmable gate array (FPGA) or other programmable logic device, discrete gate or transistor logic, discrete hardware components, or any combination thereof designed to perform the functions described herein. A general purpose processor may be a microprocessor, but in the alternative, the processor may be any conventional processor, controller, microcontroller, or state machine. A processor may also be implemented as a combination of computing devices, e.g., a combination of a DSP and a microprocessor, a plurality of microprocessors, one or more microprocessors in conjunction with a DSP core, or any other such configuration.

[0087] Furthermore, the one or more versions may be implemented as a method, apparatus, or article of manufacture using standard programming and/or engineering techniques to produce software, firmware, hardware, or any combination thereof to control a computer to implement the disclosed aspects. The term "article of manufacture" (or alternatively, "computer program product")

as used herein is intended to encompass a computer program accessible from any computer-readable device, carrier, or media. For example, computer readable media can include but are not limited to magnetic storage devices (e.g., hard disk, floppy disk, magnetic strips...), optical disks (e.g., compact disk (CD), digital versatile disk (DVD)...), smart cards, and flash memory devices (e.g., card, stick). Additionally it should be appreciated that a carrier wave can be employed to carry computer-readable electronic data such as those used in transmitting and receiving electronic mail or in accessing a network such as the Internet or a local area network (LAN). Of course, those skilled in the art will recognize many modifications may be made to this configuration without departing from the scope of the disclosed aspects.

[0088] The steps of a method or algorithm described in connection with the embodiments disclosed herein may be embodied directly in hardware, in a software module executed by a processor, or in a combination of the two. A software module may reside in RAM memory, flash memory, ROM memory, EPROM memory, EEPROM memory, registers, hard disk, a removable disk, a CD-ROM, or any other form of storage medium known in the art. An exemplary storage medium is coupled to the processor such the processor can read information from, and write information to, the storage medium. In the alternative, the storage medium may be integral to the processor. The processor and the storage medium may reside in an ASIC. The ASIC may reside in a user terminal. In the alternative, the processor and the storage medium may reside as discrete components in a user terminal.

[0089] The previous description of the disclosed embodiments is provided to enable any person skilled in the art to make or use the present disclosure. Various modifications to these embodiments will be readily apparent to those skilled in the art, and the generic principles defined herein may be applied to other embodiments without departing from the scope of the disclosure. Thus, the present disclosure is not intended to be limited to the embodiments shown herein but is to be accorded the widest scope consistent with the principles and novel features disclosed herein.

[0090] In view of the exemplary systems described supra, methodologies that may be implemented in accordance with the disclosed subject matter have been described with reference to several flow diagrams. While for purposes of simplicity of explanation, the methodologies are shown and described as a series of blocks, it is to be understood and appreciated that the claimed subject matter is not limited by the order of the blocks, as some blocks may occur in different orders and/or concurrently with other blocks from what is depicted and described herein. Moreover, not all illustrated blocks may be required to implement the methodologies described herein. Additionally, it should be further appreciated that the methodologies disclosed herein are capable of being stored on an article of manufacture to facilitate transporting and transferring such methodologies to computers.

The term article of manufacture, as used herein, is intended to encompass a computer program accessible from any computer-readable device, carrier, or media.

[0091] It should be appreciated that any patent, publication, or other disclosure material, in whole or in part, that is said to be incorporated by reference herein is incorporated herein only to the extent that the incorporated material does not conflict with existing definitions, statements, or other disclosure material set forth in this disclosure. As such, and to the extent necessary, the disclosure as explicitly set forth herein supersedes any conflicting material incorporated herein by reference. Any material, or portion thereof, that is said to be incorporated by reference herein, but which conflicts with existing definitions, statements, or other disclosure material set forth herein, will only be incorporated to the extent that no conflict arises between that incorporated material and the existing disclosure material.

Claims

1. A method for multiple carrier wireless communication, comprising:

receiving (202) an anchor carrier that assigns resources for a group of uplink non-anchor carriers;
 detecting (210) an uplink grant carried on the anchor carrier that assigns resources for the group of uplink non-anchor carriers;
 utilizing (214) the assigned resources by transmitting on the group of uplink non-anchor carriers in accordance with the detected grant;
 receiving (224) an acknowledgement of receipt of the uplink non-anchor carrier transmissions on the anchor carrier that sent the uplink grant;
 accessing (226) a mapping of acknowledgements to multiple carriers;
 interpreting (228) the acknowledgement for each uplink carrier transmission utilizing the mapping; and
 retransmitting (230) the uplink carrier transmission determined to have been unsuccessfully transmitted.

2. The method of claim 1, further comprising:

detecting (204) a common system information on the anchor carrier and acquiring the non-anchor carrier by using the common system information.

3. The method of claim 1, further comprising:

receiving (204) a dedicated information on the anchor carrier; and acquiring the non-anchor carrier by using the dedicated information.

4. The method of claim 1, further comprising receiving the anchor carrier that assigns resources for a group of non-anchor carriers.

5. The method of claim 1, further comprising:

receiving one of a plurality of anchor carriers, each anchor carrier for assigning resources on a group of carriers.

6. The method of claim 1, further comprising:

receiving a non-anchor carrier; and detecting a grant carried on the non-anchor carrier that assigns resources on the non-anchor carrier.

7. The method of claim 6, further comprising receiving a non-anchor carrier that was previously received as the anchor carrier subsequent to the another carrier no longer requiring assignment of resources.

8. The method of claim 1, further comprising:

initiating single carrier communication by synchronizing to the anchor carrier; and detecting a grant on the anchor carrier for a single carrier configured user equipment.

9. The method of claim 8, further comprising:

synchronizing to primary and secondary synchronization signals of the anchor carrier;
 detecting master information block on a Physical Broadcast Channel informing system bandwidth, Physical Hybrid Automatic Repeat Request Indicator Channel (PHICH) configuration, system frame number; and
 detecting system information blocks on downlink shared channel (DL-SCH) for resources on the anchor carrier.

10. The method of claim 8, further comprising detecting the grant on the anchor carrier for the single carrier configured user equipment by executing a redirection message to another carrier by intra-cell inter-frequency handover.

11. The method of claim 1, further comprising detecting system information blocks on the anchor carrier for utilizing the another carrier comprising carrier location, carrier bandwidth, carrier uplink or downlink designation, carrier pairing, and a new control region.

12. The method of claim 1, further comprising:

receiving an uplink grant on the anchor carrier;

and
determining an implicit pairing to an uplink carrier.

13. The method of claim 1, further comprising:

receiving an uplink grant on the anchor carrier;
and
detecting an explicitly identified uplink carrier.

14. The method of claim 1, further comprising transmitting channel quality indicator (CQI) feedback for multiple downlink carriers on an uplink anchor carrier.

15. The method of claim 1, further comprising:

reporting channel quality indicator (CQI) feedback conveying interference jamming receipt of the another carrier; and
receiving a grant assigning resources on a carrier not jammed by the interference.

16. The method of claim 1, further comprising:

receiving interference jamming receipt of the anchor carrier;
acquiring the another carrier comprising a non-anchor carrier; and
detecting a grant carried on the non-anchor carrier that assigns resources on the non-anchor carrier.

17. An apparatus for multiple carrier wireless communication, comprising:

means for receiving an anchor carrier that assigns resources for a group of uplink non-anchor carriers;
means for detecting an uplink grant carried on the anchor carrier that assigns resources for the group of uplink non-anchor carriers;
means for utilizing the assigned resources by transmitting on the group of uplink non-anchor carriers in accordance with the detected grant;
means for receiving an acknowledgement of receipt of the uplink non-anchor carrier transmissions on the anchor carrier that sent the uplink grant;
means for accessing a mapping of acknowledgements to multiple carriers;
means for interpreting the acknowledgement for each uplink carrier transmission utilizing the mapping; and
means for retransmitting the uplink carrier transmission determined to have been unsuccessfully transmitted.

18. A method for multiple carrier wireless communication, comprising:

tion, comprising:

scheduling resources for an anchor carrier and a group of non-anchor uplink carriers;
transmitting a grant on the anchor carrier that assigns resources on the group of non-anchor carriers;
communicating with a recipient that utilizes the assigned resources by transmitting on the group of non-anchor carriers in accordance with the grant;
transmitting acknowledgement of receipt of the uplink carrier transmission on the anchor carrier that sent the uplink grant;
accessing a mapping of acknowledgements to multiple carriers;
transmitting the acknowledgement for each uplink carrier transmission utilizing the mapping; and
receiving retransmission of the uplink carrier transmission that was not acknowledged as successfully received.

19. An apparatus for multiple carrier wireless communication, comprising:

means for scheduling resources for an anchor carrier and a group of non-anchor carriers;
means for transmitting a grant on the anchor carrier that assigns resources on the a group of non-anchor carriers;
means for communicating with a recipient that utilizes the assigned resources by transmitting on the group of non-anchor carriers in accordance with the grant;
means for transmitting acknowledgement of receipt of the uplink carrier transmission on the anchor carrier that sent the uplink grant;
means for accessing a mapping of acknowledgements to multiple carriers;
means for transmitting the acknowledgement for each uplink carrier transmission utilizing the mapping; and
means for receiving retransmission of the uplink carrier transmission that was not acknowledged as successfully received.

20. A computer program product comprising at least one computer readable storage medium storing computer executable instructions that when executed by at least one processor perform the method according to any one of claims 1 to 16 or 18.

Patentansprüche

1. Ein Verfahren für eine drahtlose Vielfachträger-Kommunikation, aufweisend:

- Empfangen (202) eines Ankerträgers, der Ressourcen für eine Gruppe von Aufwärtsstrecke-nicht-Ankerträgern zuweist, Erfassen (210) einer Aufwärtsstreckengewährung, die auf dem Ankerträger getragen wird, der Ressourcen für die Gruppe von Aufwärtsstrecke-nicht-Ankerträgern zuweist, Nutzen (214) der zugewiesenen Ressourcen durch das Senden auf der Gruppe von Aufwärtsstrecke-nicht-Ankerträgern gemäß der erfassten Gewährung, Empfangen (224) einer Empfangsbestätigung der Aufwärtsstrecke-nicht-Ankerträger-Sendungen auf dem Ankerträger, der die Aufwärtsstreckengewährung gesendet hat, Zugreifen (226) auf ein Mapping von Bestätigungen zu mehreren Trägern, Interpretieren (228) der Bestätigung für jede Aufwärtsstrecke-Trägersendung unter Verwendung des Mappings, und erneutes Senden (230) der Aufwärtsstrecke-Trägersendung, die als nicht erfolgreich gesendet bestimmt wird.
2. Verfahren nach Anspruch 1, das weiterhin aufweist: 25
- Erfassen (204) von gemeinsamen Systeminformationen auf dem Ankerträger und Erhalten des nicht-Ankerträgers unter Verwendung der gemeinsamen Systeminformationen. 30
3. Verfahren nach Anspruch 1, das weiterhin aufweist: 35
- Empfangen (204) von dedizierten Informationen auf dem Ankerträger, und Erhalten des nicht-Ankerträgers unter Verwendung der dedizierten Informationen.
4. Verfahren nach Anspruch 1, das weiterhin das Empfangen des Ankerträgers, der Ressourcen für eine Gruppe von nicht-Ankerträgern zuweist, aufweist. 40
5. Verfahren nach Anspruch 1, das weiterhin aufweist: 45
- Empfangen eines aus einer Vielzahl von Ankerträgern, wobei jeder Ankerträger für das Zuweisen von Ressourcen auf einer Gruppe von Trägern dient.
6. Verfahren nach Anspruch 1, das weiterhin aufweist: 50
- Empfangen eines nicht-Ankerträgers, und Erfassen einer Gewährung, die auf dem nicht-Ankerträger getragen wird, der Ressourcen auf dem nicht-Ankerträger zuweist. 55
7. Verfahren nach Anspruch 6, das weiterhin das Empfangen eines nicht-Ankerträgers, der zuvor als der Ankerträger empfangen wurde, darauf folgend, dass der andere Träger keine Zuweisung von Ressourcen mehr benötigt, aufweist.
8. Verfahren nach Anspruch 1, das weiterhin aufweist: 5
- Einleiten einer Einzelträger-Kommunikation durch das Synchronisieren mit dem Ankerträger, und 10
- Erfassen einer Gewährung auf dem Ankerträger für eine Einzelträger-konfigurierte Benutzerausstattung.
9. Verfahren nach Anspruch 8, das weiterhin aufweist: 15
- Synchronisieren mit primären und sekundären Synchronisationssignalen des Ankerträgers, Erfassen eines Master-Informationsblocks auf einer Physical Broadcast Channel-Informationssystembandbreite-Physical Hybrid Automatic Repeat Request Indicator Channel (PHICH)-Konfiguration-Systemrahmennummer, und 20
- Erfassen von Systeminformationsblöcken auf einem gemeinsamen Abwärtsstreckenkanal (DL-SCH) für Ressourcen auf dem Ankerträger.
10. Verfahren nach Anspruch 8, das weiterhin das Erfassen der Gewährung auf dem Ankerträger für die Einzelträger-konfigurierte Benutzerausstattung durch das Ausführen einer Weiterleitungsnachricht an einem anderen Träger mittels eines Intrazellen-Interfrequenz-Handovers aufweist.
11. Verfahren nach Anspruch 1, das weiterhin das Erfassen von Systeminformationsblöcken auf dem Ankerträger für das Verwenden des anderen Trägers einschließlich von Trägerposition, Trägerbandbreite, Aufwärtsstrecke/Abwärtsstrecke-Trägerzuweisung, Trägerpaarung und eines neuen Steuerbereichs aufweist.
12. Verfahren nach Anspruch 1, das weiterhin aufweist: 25
- Empfangen einer Aufwärtsstreckengewährung auf dem Ankerträger, und Bestimmen einer impliziten Paarung mit einem Aufwärtsstreckenträger.
13. Verfahren nach Anspruch 1, das weiterhin aufweist: 30
- Empfangen einer Aufwärtsstreckengewährung auf dem Ankerträger, und Erfassen eines explizit identifizierten Aufwärtsstreckenträgers.
14. Verfahren nach Anspruch 1, das weiterhin das Senden einer Kanalqualitätsindikator (CQI)-Rückmel-

derung für mehrere Abwärtsstreckenträger auf einem Aufwärtsstrecke-Ankerträger aufweist.

15. Verfahren nach Anspruch 1, das weiterhin aufweist:

Berichten einer Kanalqualitätsindikator (CQI)-Rückmeldung, die einen Störungstauempfang des anderen Trägers meldet, und Empfangen einer Gewährung, die Ressourcen auf einem nicht durch die Störung gestauten Träger zuweist.

16. Verfahren nach Anspruch 1, das weiterhin aufweist:

Empfangen eines Störungstauempfangs des Ankerträgers, Erhalten des anderen Trägers, der einen nicht-Ankerträger aufweist, und Erfassen einer Gewährung, die auf dem nicht-Ankerträger getragen wird, der Ressourcen auf dem nicht-Ankerträger zuweist.

17. Eine Vorrichtung für eine drahtlose Vielfachträger-Kommunikation, aufweisend:

Mittel zum Empfangen eines Ankerträgers, der Ressourcen für eine Gruppe von Aufwärtsstrecke-nicht-Ankerträgern zuweist, Mittel zum Erfassen einer Aufwärtsstreckengewährung, die auf dem Ankerträger getragen wird, der Ressourcen für die Gruppe von Aufwärtsstrecke-nicht-Ankerträgern zuweist, Mittel zum Nutzen der zugewiesenen Ressourcen durch das Senden auf der Gruppe von Aufwärtsstrecke-nicht-Ankerträgern gemäß der erfassten Gewährung, Mittel zum Empfangen einer Empfangsbestätigung der Aufwärtsstrecke-nicht-Ankerträger-Sendungen auf dem Ankerträger, der die Aufwärtsstreckengewährung gesendet hat, Mittel zum Zugreifen auf ein Mapping von Bestätigungen zu mehreren Trägern, Mittel zum Interpretieren der Bestätigung für jede Aufwärtsstrecke-Trägersendung unter Verwendung des Mappings, und Mittel zum erneuten Senden der Aufwärtsstrecke-Trägersendung, die als nicht erfolgreich gesendet bestimmt wird.

18. Ein Verfahren für eine drahtlose Vielfachträger-Kommunikation, aufweisend:

Planen von Ressourcen für einen Ankerträger und eine Gruppe von Aufwärtsstrecke-nicht-Ankerträgern, Senden einer Gewährung auf dem Ankerträger, der Ressourcen auf der Gruppe von nicht-Ankerträgern zuweist,

Kommunizieren mit einem Empfänger, der die zugewiesenen Ressourcen nutzt, durch das Senden auf der Gruppe von nicht-Ankerträgern gemäß der Gewährung,

Senden einer Empfangsbestätigung der Aufwärtsstrecke-Trägersendung auf dem Ankerträger, der die Aufwärtsstreckengewährung gesendet hat,

Zugreifen auf ein Mapping von Bestätigungen zu mehreren Trägern,

Senden der Bestätigung für jede Aufwärtsstrecke-Trägersendung unter Verwendung des Mappings, und

Empfangen einer erneuten Sendung der Aufwärtsstrecke-Trägersendung, die als nicht erfolgreich bestätigt wurde.

19. Eine Vorrichtung für eine drahtlose Vielfachträger-Kommunikation, aufweisend:

Mittel zum Planen von Ressourcen für einen Ankerträger und eine Gruppe von nicht-Ankerträgern,

Mittel zum Senden einer Gewährung auf dem Ankerträger, der Ressourcen auf der Gruppe von nicht-Ankerträgern zuweist,

Mittel zum Kommunizieren mit einem Empfänger, der die zugewiesenen Ressourcen nutzt, durch das Senden auf der Gruppe von nicht-Ankerträgern gemäß der Gewährung,

Mittel zum Senden einer Empfangsbestätigung der Aufwärtsstrecke-Trägersendung auf dem Ankerträger, der die Aufwärtsstreckengewährung gesendet hat,

Mittel zum Zugreifen auf ein Mapping von Bestätigungen zu mehreren Trägern,

Mittel zum Senden der Bestätigung für jede Aufwärtsstrecke-Trägersendung unter Verwendung des Mappings, und

Mittel zum Empfangen einer erneuten Sendung der Aufwärtsstrecke-Trägersendung, die als nicht erfolgreich bestätigt wurde.

20. Ein Computerprogrammprodukt, das wenigstens ein computerlesbares Speichermedium aufweist, auf dem computerausführbare Befehle gespeichert sind, die bei einer Ausführung durch wenigstens einen Prozessor das Verfahren gemäß einem der Ansprüche 1 bis 16 oder 18 durchführen.

Revendications

1. Procédé de communication sans fil à porteuses multiples, comprenant les étapes ci-dessous consistant à :

recevoir (202) une porteuse d'ancrage qui af-

- fecte des ressources pour un groupe de porteuses de non-ancrage de liaison montante ; détecter (210) un octroi de liaison montante transporté sur la porteuse d'ancrage qui affecte des ressources pour le groupe de porteuses de non-ancrage de liaison montante ; utiliser (214) les ressources affectées en émettant sur le groupe de porteuses de non-ancrage de liaison montante conformément à l'octroi détecté ; recevoir (224) un accusé de réception des transmissions de porteuses de non-ancrage de liaison montante sur la porteuse d'ancrage ayant envoyé l'octroi de liaison montante ; accéder (226) à une mise en correspondance d'accusés de réception avec de porteuses multiples ; interpréter (228) l'accusé de réception pour chaque transmission de porteuse de liaison montante en utilisant la mise en correspondance ; et retransmettre (230) la transmission de porteuse de liaison montante déterminée comme ayant été transmise sans succès.
2. Procédé selon la revendication 1, comprenant en outre les étapes ci-dessous consistant à :
- détecter (204) des informations de système communes sur la porteuse d'ancrage et acquérir la porteuse de non-ancrage en faisant appel aux informations de système communes.
3. Procédé selon la revendication 1, comprenant en outre les étapes ci-dessous consistant à :
- recevoir (204) des informations dédiées sur la porteuse d'ancrage ; et acquérir la porteuse de non-ancrage en faisant appel aux informations dédiées.
4. Procédé selon la revendication 1, comprenant en outre l'étape consistant à recevoir la porteuse d'ancrage qui affecte des ressources pour un groupe de porteuses de non-ancrage.
5. Procédé selon la revendication 1, comprenant en outre l'étape ci-dessous consistant à :
- recevoir l'une d'une pluralité de porteuses d'ancrage, chaque porteuse d'ancrage étant destinée à affecter des ressources sur un groupe de porteuses.
6. Procédé selon la revendication 1, comprenant en outre l'étape ci-dessous consistant à :
- recevoir une porteuse de non-ancrage ; et détecter un octroi transporté sur la porteuse de non-ancrage qui affecte des ressources sur la porteuse de non-ancrage.
7. Procédé selon la revendication 6, comprenant en outre l'étape consistant à recevoir une porteuse de non-ancrage qui a été précédemment reçue en tant que la porteuse d'ancrage subséquente à ladite une autre porteuse n'exigeant plus d'affectation de ressources.
8. Procédé selon la revendication 1, comprenant en outre les étapes ci-dessous consistant à :
- initier une communication à porteuse unique par une synchronisation sur la porteuse d'ancrage ; et détecter un octroi sur la porteuse d'ancrage pour un équipement d'utilisateur configuré pour une porteuse unique.
9. Procédé selon la revendication 8, comprenant en outre les étapes ci-dessous consistant à :
- mettre en oeuvre une synchronisation sur des signaux de synchronisation primaires et secondaires de la porteuse d'ancrage ; détecter un bloc d'informations maître sur une bande passante de système d'information de canal de diffusion physique, une configuration de canal indicateur de demande de répétition automatique hybride physique (PHICH), un numéro de trame de système ; et détecter des blocs d'informations de système sur un canal partagé en liaison descendante (DL-SCH) pour des ressources sur la porteuse d'ancrage.
10. Procédé selon la revendication 8, comprenant en outre l'étape consistant à détecter l'octroi sur la porteuse d'ancrage pour l'équipement d'utilisateur configuré pour une porteuse unique, en exécutant un message de redirection vers une autre porteuse par un transfert intracellulaire inter-fréquences.
11. Procédé selon la revendication 1, comprenant en outre l'étape consistant à détecter des blocs d'informations de système sur la porteuse d'ancrage pour utiliser ladite une autre porteuse, comprenant un emplacement de porteuse, une largeur de bande de porteuse, une désignation de liaison montante et de liaison descendante de porteuse, un jumelage de porteuses et une nouvelle zone de commande.
12. Procédé selon la revendication 1, comprenant en outre les étapes ci-dessous consistant à :
- recevoir un octroi de liaison montante sur la porteuse d'ancrage ; et

- déterminer un jumelage implicite avec une porteuse de liaison montante.
- 13.** Procédé selon la revendication 1, comprenant en outre les étapes ci-dessous consistant à :
- recevoir un octroi de liaison montante sur la porteuse d'ancrage ; et
détecter une porteuse de liaison montante explicitement identifiée.
- 14.** Procédé selon la revendication 1, comprenant en outre l'étape consistant à transmettre une rétroaction d'indicateur de qualité de canal (CQI) pour de porteuses multiples de liaison descendante sur une porteuse d'ancrage de liaison montante.
- 15.** Procédé selon la revendication 1, comprenant en outre les étapes ci-dessous consistant à :
- signaler une rétroaction d'indicateur de qualité de canal (CQI) transportant une réception d'interférence provoquant un phénomène de brouillage de ladite une autre porteuse ; et
recevoir un octroi affectant des ressources sur une porteuse non brouillée intentionnellement par les interférences.
- 16.** Procédé selon la revendication 1, comprenant en outre les étapes ci-dessous consistant à :
- recevoir une réception d'interférence provoquant un phénomène de brouillage de la porteuse d'ancrage ;
acquérir ladite une autre porteuse comprenant une porteuse de non-ancrage ; et
détecter un octroi transporté sur la porteuse de non-ancrage qui affecte des ressources sur la porteuse de non-ancrage.
- 17.** Appareil pour une communication sans fil à porteuses multiples, comprenant :
- un moyen pour recevoir une porteuse d'ancrage qui affecte des ressources pour un groupe de porteuses de non-ancrage de liaison montante ;
un moyen pour détecter un octroi de liaison montante transporté sur la porteuse d'ancrage, qui affecte des ressources pour le groupe de porteuses de non-ancrage de liaison montante ;
un moyen pour utiliser les ressources affectées en émettant sur le groupe de porteuses de non-ancrage de liaison montante conformément à l'octroi détecté ;
un moyen pour recevoir un accusé de réception des transmissions de porteuses de non-ancrage de liaison montante sur la porteuse d'ancrage ayant envoyé l'octroi de liaison montante ;
- un moyen pour accéder à une mise en correspondance d'accusés de réception avec de porteuses multiples ;
un moyen pour interpréter l'accusé de réception pour chaque transmission de porteuse de liaison montante en utilisant la mise en correspondance ; et
un moyen pour retransmettre la transmission de porteuse de liaison montante déterminée comme ayant été transmise sans succès.
- 18.** Procédé pour une communication sans fil à porteuses multiples, comprenant les étapes ci-dessous consistant à :
- planifier des ressources pour une porteuse d'ancrage et un groupe de porteuses de non-ancrage de liaison montante ;
transmettre un octroi sur la porteuse d'ancrage qui affecte des ressources sur le groupe de porteuses de non-ancrage ;
communiquer avec un destinataire qui utilise les ressources affectées en émettant sur le groupe de porteuses de non-ancrage conformément à l'octroi ;
transmettre un accusé de réception de la transmission de porteuse de liaison montante sur la porteuse d'ancrage qui a envoyé l'octroi de liaison montante ;
accéder à une mise en correspondance d'accusés de réception avec de porteuses multiples ;
transmettre l'accusé de réception pour chaque transmission de porteuse de liaison montante en utilisant la mise en correspondance ; et
recevoir une retransmission de la transmission de porteuse de liaison montante qui n'a pas été reconnue comme ayant été reçue correctement.
- 19.** Appareil de communication sans fil à porteuses multiples, comprenant:
- un moyen pour planifier des ressources pour une porteuse d'ancrage et un groupe de porteuses de non-ancrage ;
un moyen pour transmettre un octroi sur la porteuse d'ancrage qui affecte des ressources sur le groupe de porteuses de non-ancrage ;
un moyen pour communiquer avec un destinataire qui utilise les ressources affectées en émettant sur le groupe de porteuses de non-ancrage conformément à l'octroi ;
un moyen pour transmettre un accusé de réception de la transmission de porteuse de liaison montante sur la porteuse d'ancrage qui a envoyé l'octroi de liaison montante ;
un moyen pour accéder à une mise en correspondance d'accusés de réception avec de porteuses multiples ;

un moyen pour transmettre l'accusé de réception pour chaque transmission de porteuse de liaison montante en utilisant la mise en correspondance ; et

un moyen pour recevoir une retransmission de la transmission de porteuse de liaison montante qui n'a pas été reconnue comme ayant été reçue correctement.

20. Produit formant programme informatique comprenant au moins un support de stockage lisible par ordinateur stockant des instructions exécutables par ordinateur, qui, lorsqu'elles sont exécutées par au moins un processeur, mettent en oeuvre le procédé selon l'une quelconque des revendications 1 à 16 ou 18.

20

25

30

35

40

45

50

55

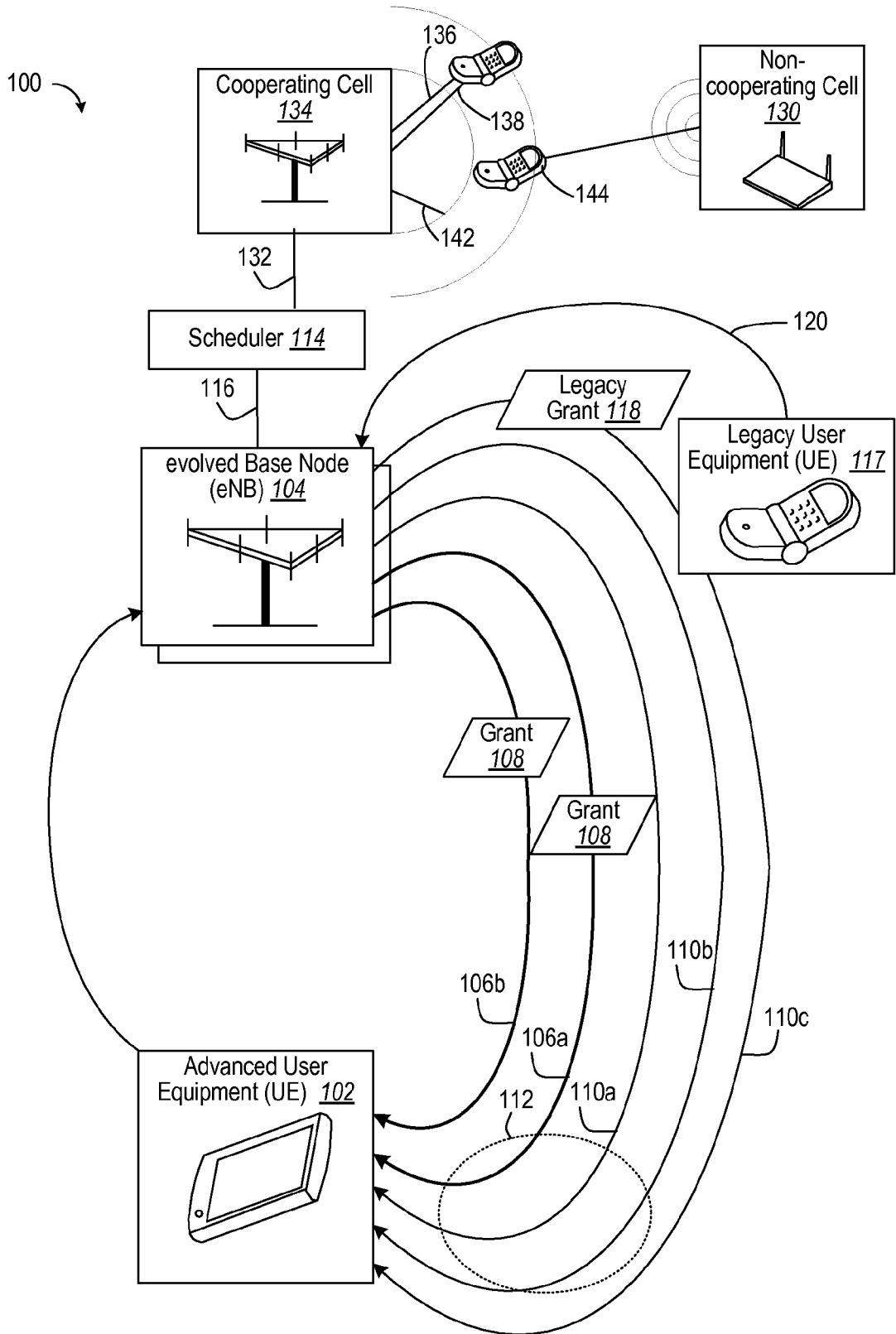

FIG. 1

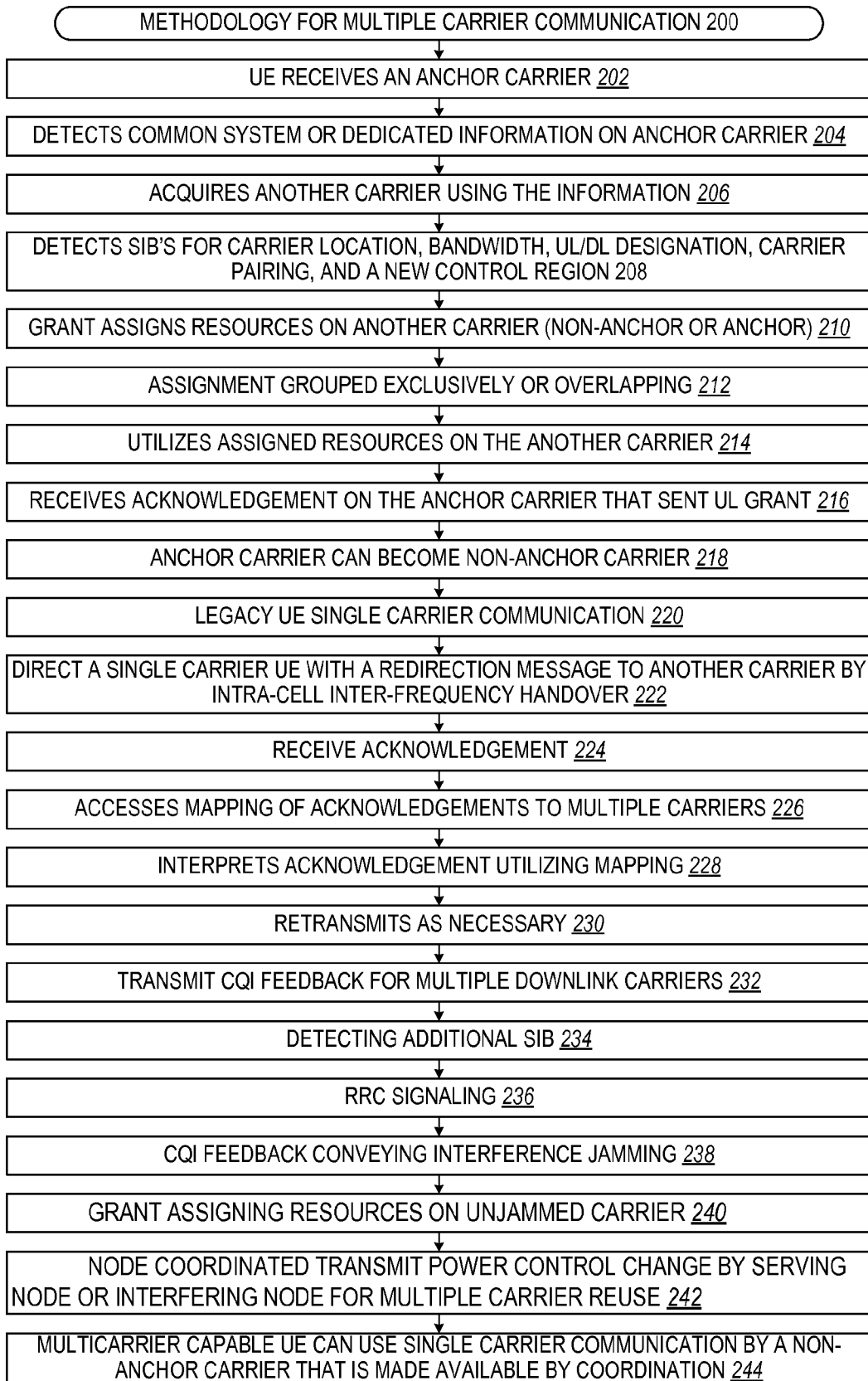

FIG. 2

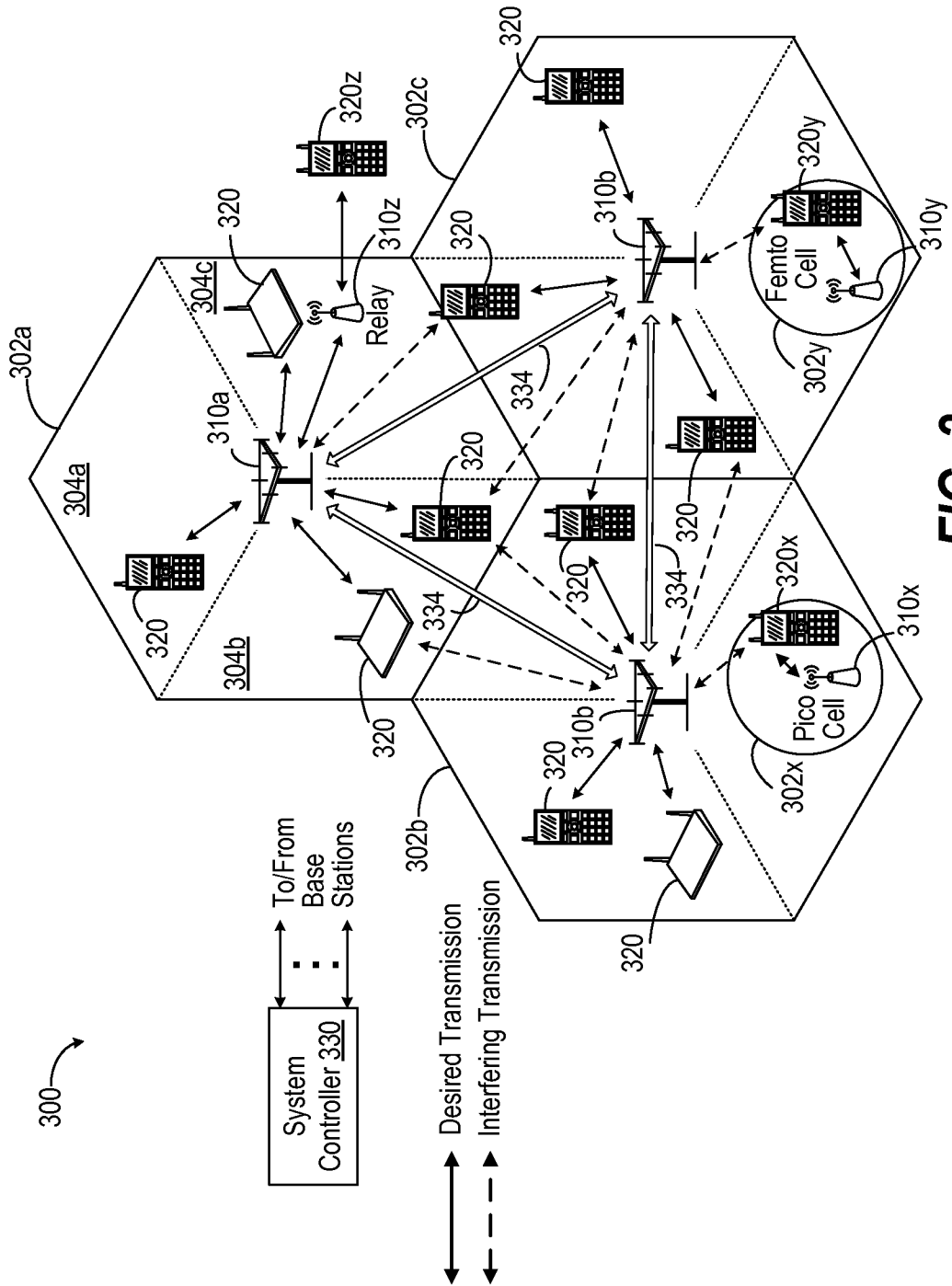

FIG. 3

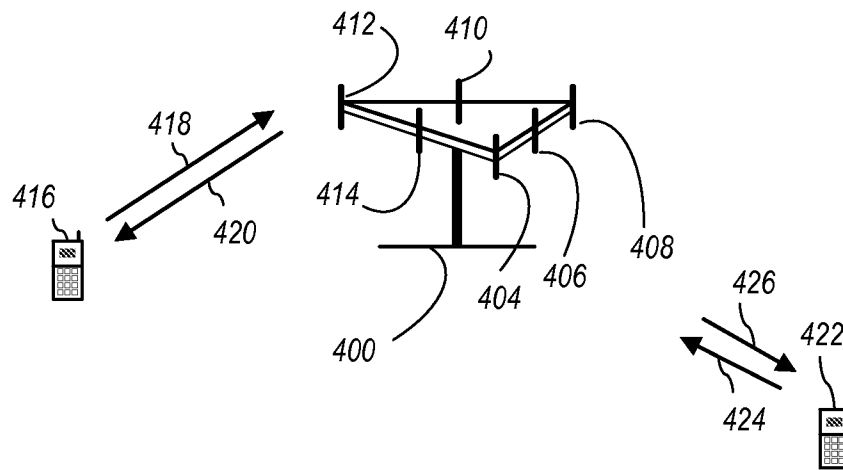

FIG. 4

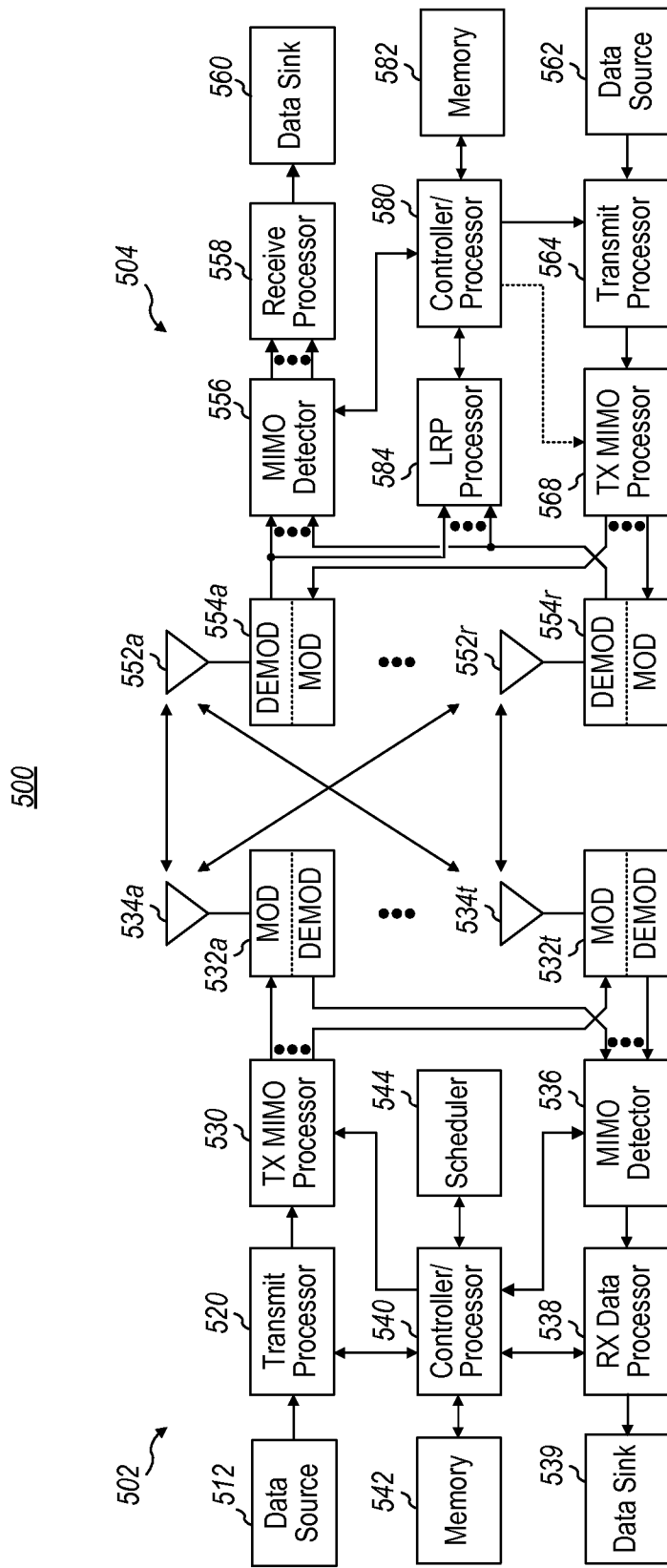

FIG. 5

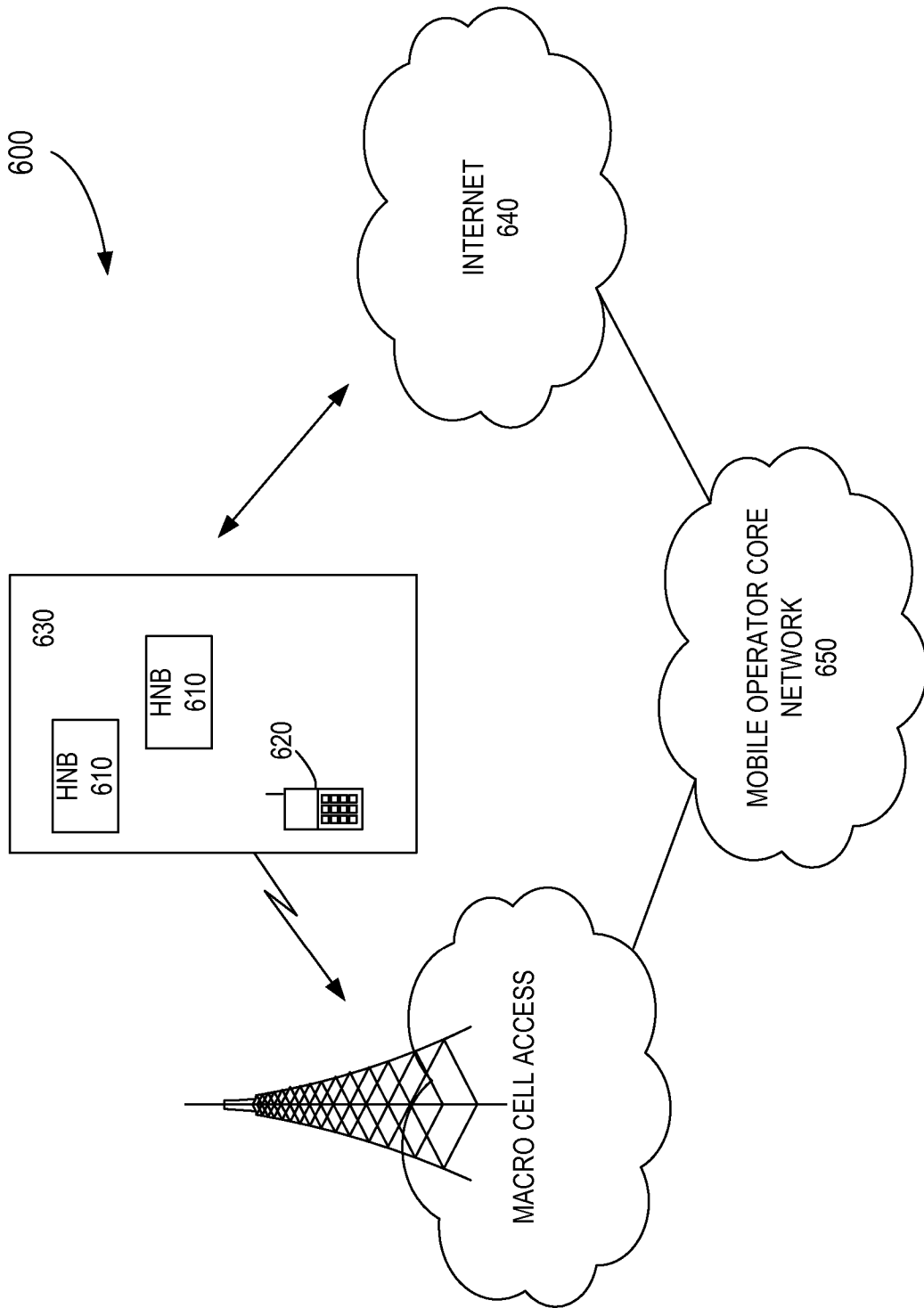

FIG. 6

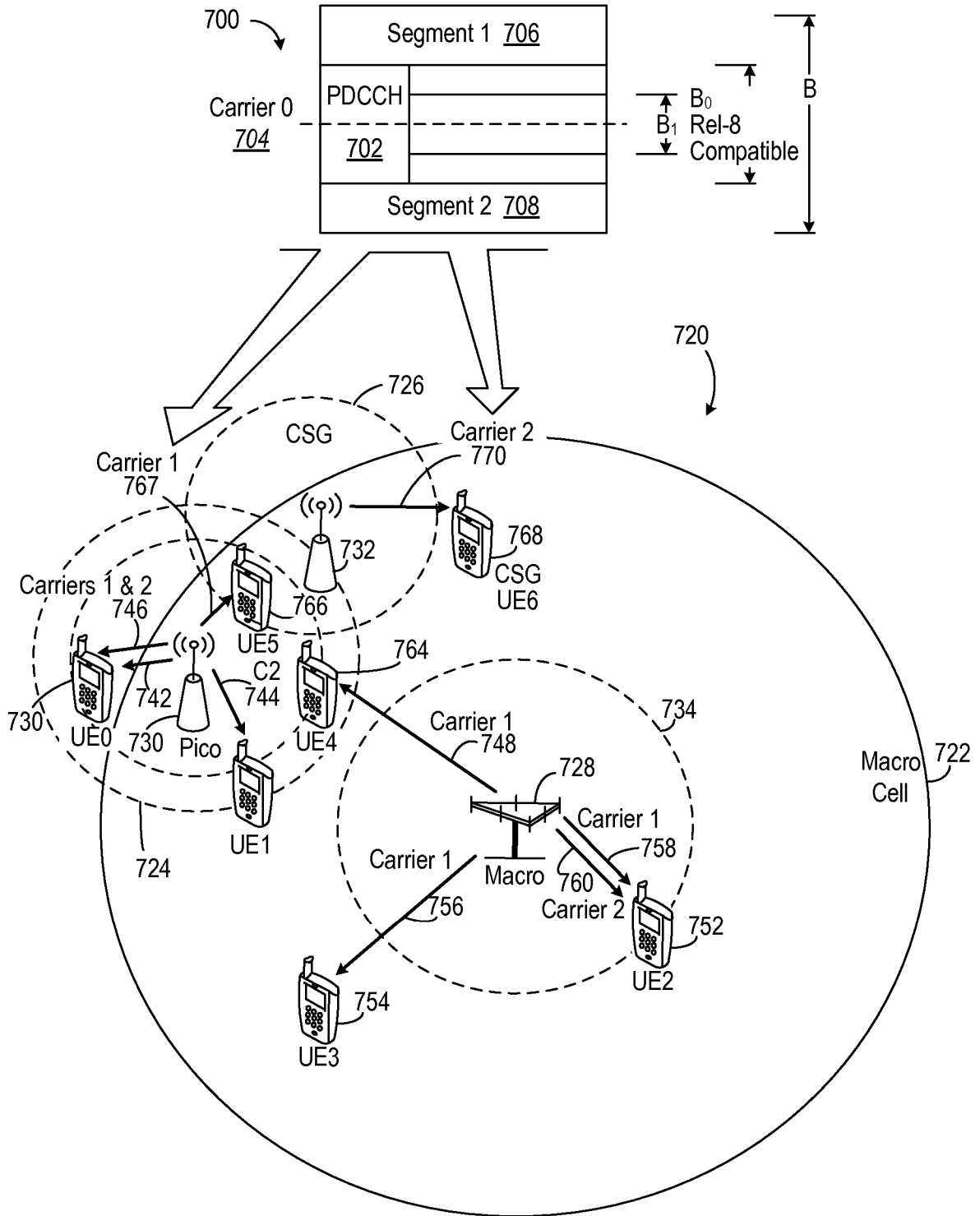

FIG. 7

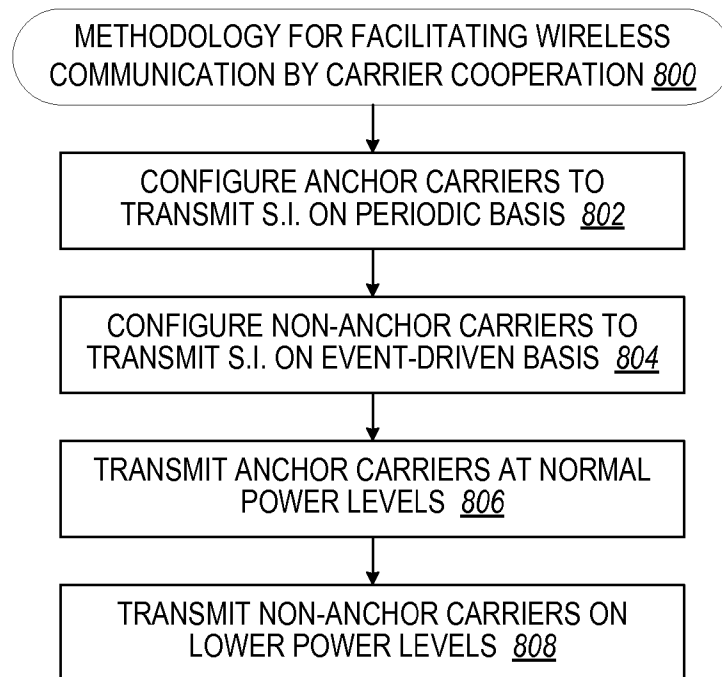

FIG. 8

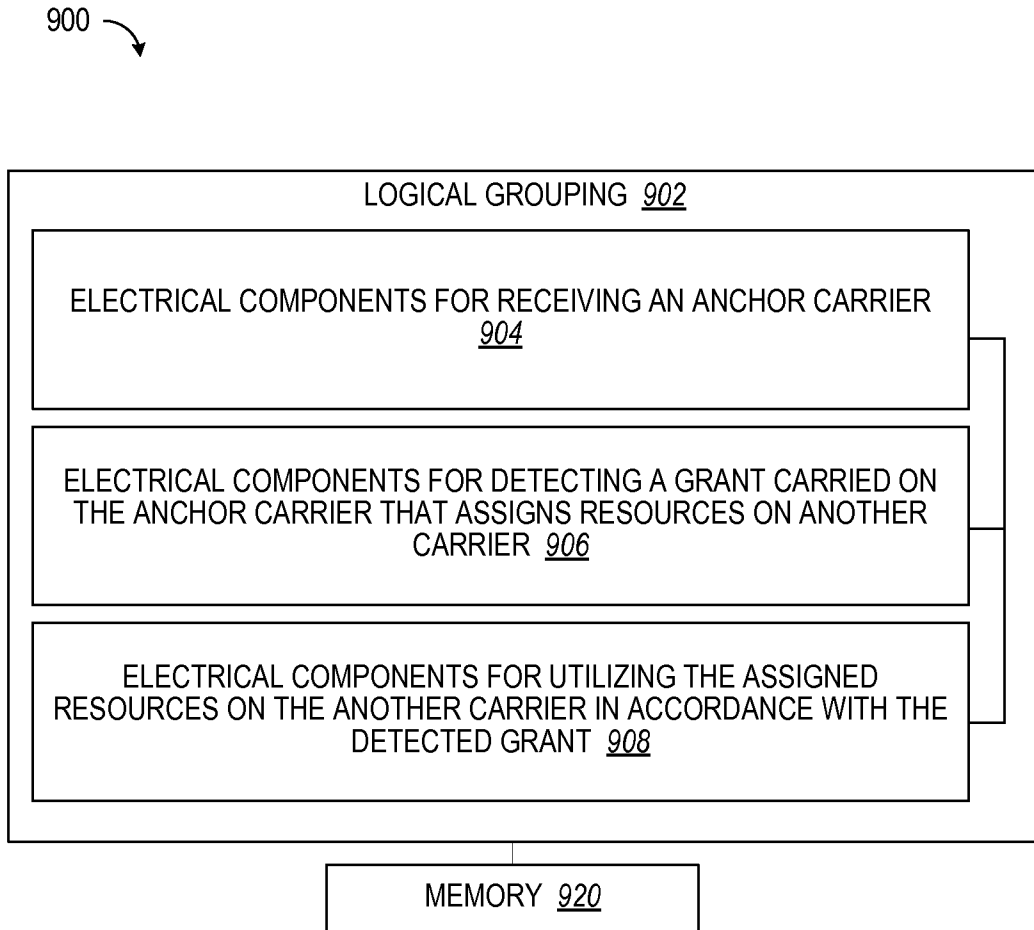

FIG. 9

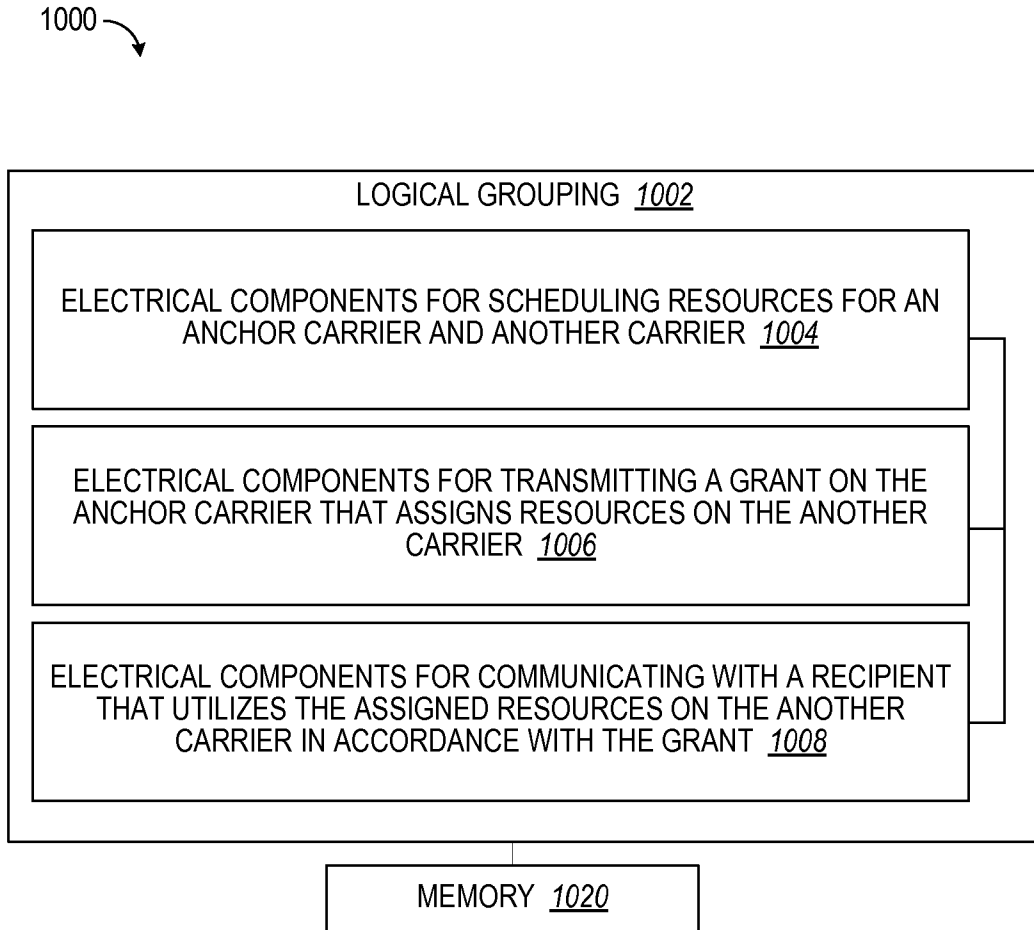

FIG. 10

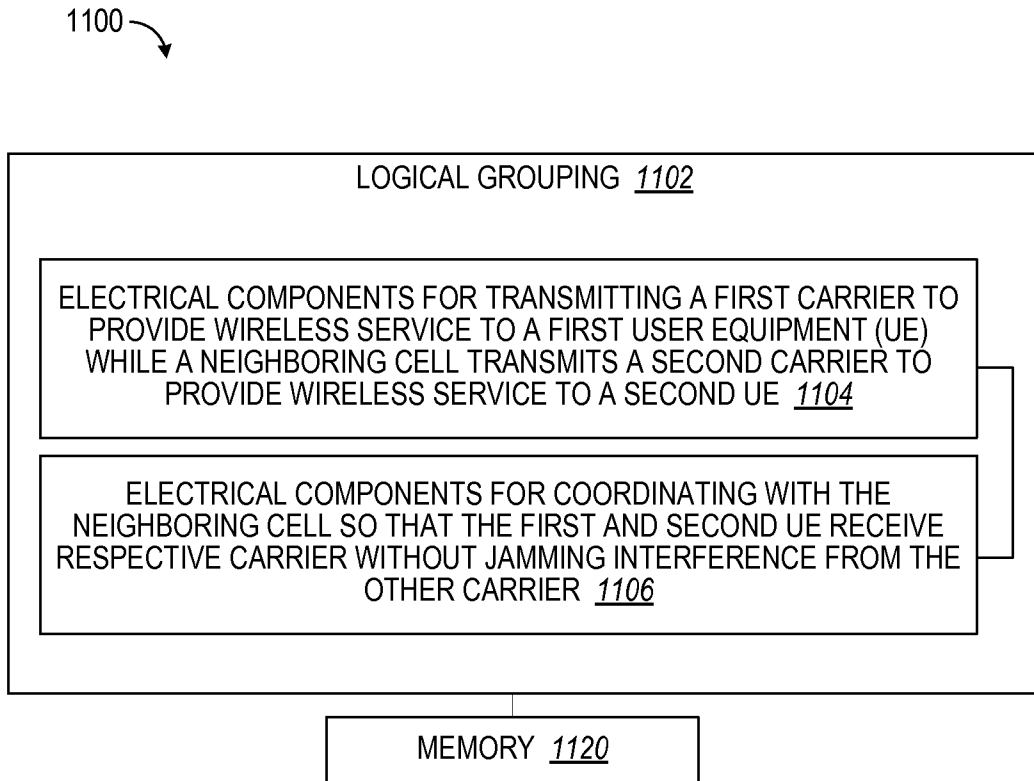

FIG. 11

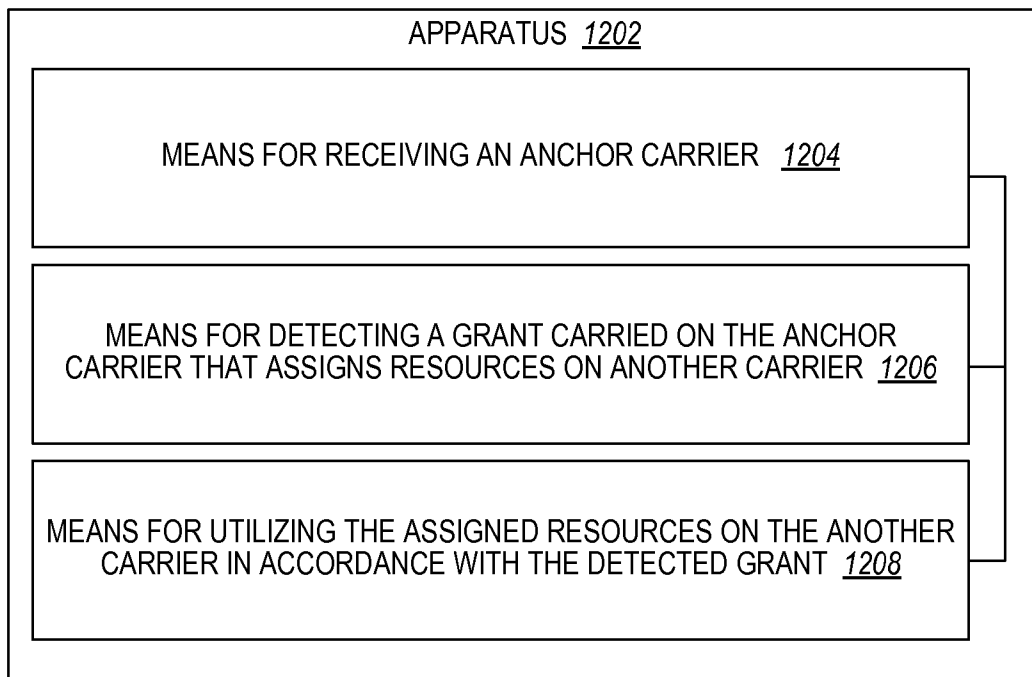

FIG. 12

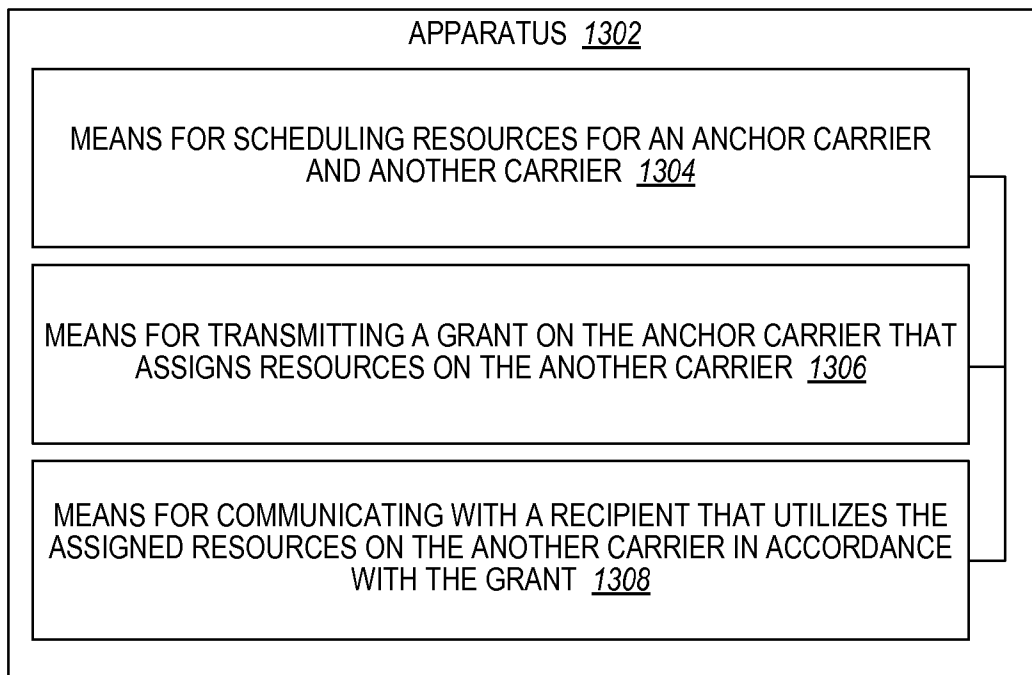

FIG. 13

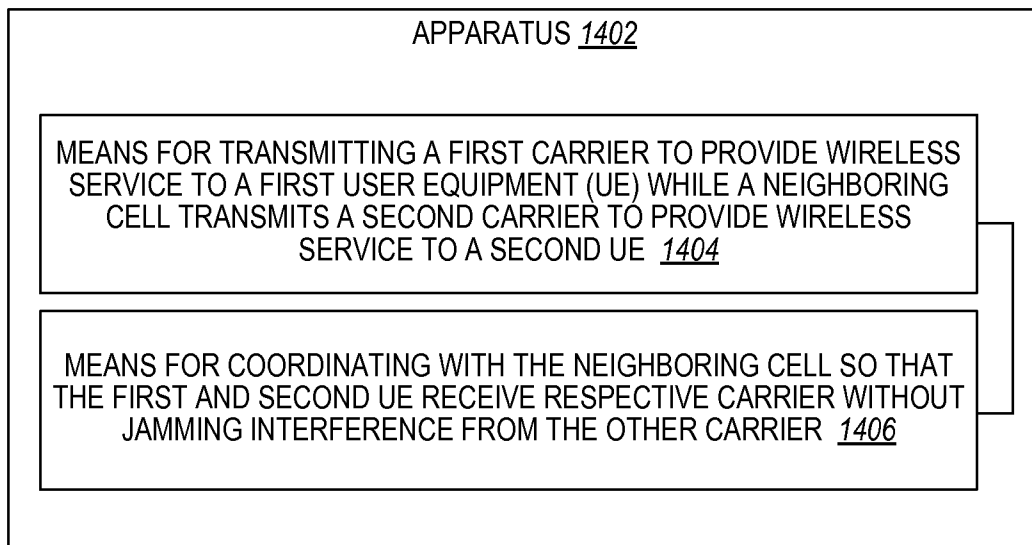

FIG. 14

REFERENCES CITED IN THE DESCRIPTION

This list of references cited by the applicant is for the reader's convenience only. It does not form part of the European patent document. Even though great care has been taken in compiling the references, errors or omissions cannot be excluded and the EPO disclaims all liability in this regard.

Patent documents cited in the description

- WO 2006125149 A2 [0005]
- US 20070091817 A1 [0006]

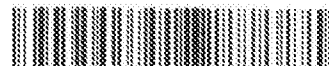

1. Eljárás többvivős vezeték nélküli kommunikációra, az eljárás tartalmazza:

egy horgony vivő vételét (202), amely erőforrásokat rendel feltöltés irányú kapcsolati nem-horgony-vivők egy csoportjához;

egy feltöltés irányú kapcsolati engedély detektálását (210), amelyet az a horgony vivő hordoz, amely erőforrásokat rendel a feltöltés irányú kapcsolati nem-horgony-vivők csoportjához;

a hozzárendelt erőforrások használatát (214) a feltöltés irányú kapcsolati nem-horgony-vivő csoport átvitele révén a detektált engedélynek megfelelően;

a feltöltés irányú kapcsolati nem-horgony-vivő átvitelek vétele nyugtázásának vételét (224) azon a horgony vivőn, amely a feltöltés irányú kapcsolati engedélyt küldte;

a nyugtázások több vivőre történt leképezéséhez való hozzáférést (226);

a nyugtázás interpretálását (228) minden egyes feltöltés irányú kapcsolati átvitelhez, a leképezés felhasználásával; és

azon feltöltés irányú kapcsolati vivő átvitel ismételt átvételét (230), amelynél azt állapítottuk meg, hogy sikertelen volt az átvitele.

2. Az 1. igénypont szerinti eljárás, amely tartalmazza továbbá:

egy közös rendszerinformáció detektálását (204) a horgony vivőn és a nem-horgony vivő megszerzését a közös rendszerinformáció felhasználásával.

3. Az 1. igénypont szerinti eljárás, amely tartalmazza továbbá:

egy dedikált információ vételét (204) a horgony vivőn, és a nem-horgony-vivő megszerzését a dedikált információ felhasználásával.

4. Az 1. igénypont szerinti eljárás, amely tartalmazza továbbá annak a horgony vivőnek a vételét, amely erőforrásokat rendel vivők egy csoportjához.

5. Az 1. igénypont szerinti eljárás, amely tartalmazza továbbá:

a horgony vivők közül egy vételét; minden egyes horgony vivő erőforrásokat rendel vivők egy csoportjához.

6. Az 1. igénypont szerinti eljárás, amely tartalmazza továbbá:

egy nem-horgony-vivő vételét; és

a nem-horgony-vivőn továbbított engedély detektálását, amely erőforrásokat rendel a nem-horgony-vivőkhöz.

7. A 6. igénypont szerinti eljárás, amely tartalmazza továbbá egy olyan nem-horgony-vivő vételét, amelyet előzőleg horgony vivőként vettünk, a másik vivőt követően, amely nem igényelte továbbá erőforrások hozzárendelését.

8. Az 1. igénypont szerinti eljárás, amely tartalmazza továbbá:

egyetlen vivő kommunikáció kezdeményezését a horgony vivőhöz történő szinkronizálás révén; és
egy engedély detektálását a horgony vivőn egy egyvivőre konfigurált felhasználói készülék számára.

9. A 8. igénypont szerinti eljárás, amely tartalmazza továbbá:

szinkronizálást a horgony vivő elsődleges és másodlagos szinkronizáló jeleihez;

master információs blokk detektálását egy fizikai broadcast csatornán, amely tájékoztatást ad rendszer sávszélességről, fizikai hibrid automatikus ismétlési kérelem indikátor csatorna (PHICH) konfigurációról, rendszer keretszámról; és

rendszerinformációs blokkok detektálását a letöltés irányú kapcsolati megosztott csatornán DL-SCH, a horgony vivőn lévő erőforrások számára.

10. A 8. igénypont szerinti eljárás, amely tartalmazza továbbá az engedély detektálását a horgony vivőn az egyvivőre konfigurált felhasználói készülék számára, egy másik vivőre mutató átirányító üzenet végrehajtása útján, cellaközi interfrekvenciás átadás révén.

11. Az 1. igénypont szerinti eljárás, amely tartalmazza továbbá rendszerinformációs blokk detektálását a horgony vivőn a másik vivő használatára, amely vivő lokációt, vivő sávszélességet, vivő feltöltés irányú kapcsolati vagy letöltés irányú kapcsolati megnevezést, vivő párosítást és egy új vezérlési régiót tartalmaz.

12. Az 1. igénypont szerinti eljárás, amely tartalmazza továbbá:

egy feltöltés irányú kapcsolati engedély vételét a horgony vivőn; és

egy implicit párosítás meghatározását egy feltöltés irányú kapcsolati vivőhöz.

13. Az 1. igénypont szerinti eljárás, amely tartalmazza továbbá:

egy feltöltés irányú kapcsolati engedély vételét a horgony vivőn; és

egy explicit módon azonosított feltöltés irányú kapcsolati vivő detektálását.

14. Az 1. igénypont szerinti eljárás, amely tartalmazza továbbá több letöltés irányú kapcsolati vivőre vonatkozó csatornaminőség indikátor (CQI) visszacsatolás átvitelét egy feltöltés irányú kapcsolati horgony vivőn.

15. Az 1. igénypont szerinti eljárás, amely tartalmazza továbbá csatornaminőség indikátor (CQI) visszacsatolás jelentését, amely a másik vivő interferencia elzáródás vételét szállítja; és

egy engedély vételét erőforrásoknak egy az interferencia által nem elzárt vivőhöz való hozzárendelésére.

16. Az 1. igénypont szerinti eljárás, amely tartalmazza továbbá:

a horgony vivő interferencia elzáródás vételének vételét;

egy nem-horgony-vivőt tartalmazó másik vivő megszerzését; és

a nem-horgony-vivőn továbbított engedély detektálását, amely erőforrásokat rendel a nem-horgony-vivőhöz.

17. Berendezés többvivős vezeték nélküli kommunikációra, amely tartalmaz:

eszközt egy horgony vivő vételére, amely erőforrásokat rendel feltöltés irányú kapcsolati nem-horgony-vivők egy csoportjához;

eszközt egy feltöltés irányú kapcsolati engedély detektálására, amelyet az a horgony vivő hordoz, amely erőforrásokat rendel a feltöltés irányú kapcsolati nem-horgony-vivők csoportjához;

eszközt a hozzárendelt erőforrások használatára a feltöltés irányú kapcsolati nem-horgony-vivő csoport átvitele révén a detektált engedélynek megfelelően;

eszközt a feltöltés irányú kapcsolati nem-horgony-vivő átvitelek vétele nyugtázásának vételére azon a horgony vivőn, amely a feltöltés irányú kapcsolati engedélyt küldte;

eszközt a nyugtázások több vivőre történt leképezéséhez való hozzáférésre;

eszközt a nyugtázás interpretálására minden egyes feltöltés irányú kapcsolati átvitelhez, a leképezés felhasználásával; és

eszközt azon feltöltés irányú kapcsolati vivő átvitel ismételt átvételére, amelynél azt állapítottuk meg, hogy sikertelen volt az átvitele.

18. Eljárás többvivős vezeték nélküli kommunikációra, az eljárás tartalmazza:

erőforrások ütemezését egy horgony vivő és nem-horgony feltöltés irányú kapcsolati vivők egy csoportja számára;

egy engedély átvitelét a horgony vivőn, amely erőforrásokat rendel a nem-horgony-vivők csoportjához;

a kommunikációt egy vevővel, amely a nem-horgony-vivők csoportjában történő átvitel révén a hozzárendelt erőforrásokat használja az engedéllyel összhangban;

a feltöltés irányú kapcsolati vivő horgony vivőn, amely a feltöltés irányú kapcsolati engedélyt küldte, való átvitel vétele nyugtázásának az átvitelét;

a nyugtázás több vivőre történő leképezéséhez való hozzáférést;

a nyugtázás átvitelét a minden egyes feltöltés irányú kapcsolati vivő átvitelhez a leképezés felhasználásával; és

a feltöltés irányú kapcsolati vivő átvitel, amelyet sikertelenül vettként nyugtáztak, újraküldésének vételét.

19. Berendezés többvivős vezeték nélküli kommunikációra, a berendezés tartalmaz:

eszközt erőforrások ütemezésére egy horgony vivő és nem-horgony feltöltés irányú kapcsolati vivők egy csoportja számára;

eszközt egy engedély átvételére a horgony vivőn, amely erőforrásokat rendel a nem-horgony-vivők csoportjához;

eszközt kommunikációra egy vevővel, amely a nem-horgony-vivők csoportjában történő átvitel révén a hozzárendelt erőforrásokat használja az engedéllyel összhangban;

eszközt a feltöltés irányú kapcsolati vivő horgony vivőn, amely a feltöltés irányú kapcsolati engedélyt küldte, való átvitel vétele nyugtázásának az átvételére;

eszközt a nyugtázás több vivőre történő leképezéséhez való hozzáférésre;

eszközt a nyugtázás átvételére a minden egyes feltöltés irányú kapcsolati vivő átvitelhez a leképezés használatával; és

eszközt a feltöltés irányú kapcsolati vivő átvitel, amelyet sikertelenül vetteként nyugtáztak, újraküldésének vételére.

20. Számítógépi program termék, amely legalább egy számítógéppel olvasható tárolóközeget tartalmaz, amely olyan számítógéppel végrehajtható utasításokat tartalmaz, amelyek legalább egy processzorral végrehajtva az 1-16. vagy 18. igénypontok bármelyike szerinti eljárást hajtják végre.