

(19) World Intellectual Property Organization
International Bureau



(43) International Publication Date
4 April 2002 (04.04.2002)

PCT

(10) International Publication Number
WO 02/26087 A2

(51) International Patent Classification⁷: A47G

(21) International Application Number: PCT/US01/29811

(22) International Filing Date:
25 September 2001 (25.09.2001)

(25) Filing Language: English

(26) Publication Language: English

(30) Priority Data:
60/235,072 25 September 2000 (25.09.2000) US

(71) Applicant and

(72) Inventor: HAKIM, Nouri, E. [US/US]; 3030 Aurora Avenue, Monroe, LA 71201 (US).

(74) Agent: COHEN, Morris, E.; 1122 Coney Island Avenue, Suite 217, Brooklyn, NY 11230-2345 (US).

(81) Designated States (national): AE, AG, AL, AM, AT, AU, AZ, BA, BB, BG, BR, BY, BZ, CA, CH, CN, CO, CR, CU,

CZ, DE, DK, DM, DZ, EC, EE, ES, FI, GB, GD, GE, GH, GM, HR, HU, ID, IL, IN, IS, JP, KE, KG, KP, KR, KZ, LC, LK, LR, LS, LT, LU, LV, MA, MD, MG, MK, MN, MW, MX, MZ, NO, NZ, PL, PT, RO, RU, SD, SE, SG, SI, SK, SL, TJ, TM, TR, TT, TZ, UA, UG, US, UZ, VN, YU, ZA, ZW.

(84) Designated States (regional): ARIPO patent (GH, GM, KE, LS, MW, MZ, SD, SL, SZ, TZ, UG, ZW), Eurasian patent (AM, AZ, BY, KG, KZ, MD, RU, TJ, TM), European patent (AT, BE, CH, CY, DE, DK, ES, FI, FR, GB, GR, IE, IT, LU, MC, NL, PT, SE, TR), OAPI patent (BF, BJ, CF, CG, CI, CM, GA, GN, GQ, GW, ML, MR, NE, SN, TD, TG).

Published:

— without international search report and to be republished upon receipt of that report

For two-letter codes and other abbreviations, refer to the "Guidance Notes on Codes and Abbreviations" appearing at the beginning of each regular issue of the PCT Gazette.

(54) Title: FEEDING DISHES FOR CHILDREN

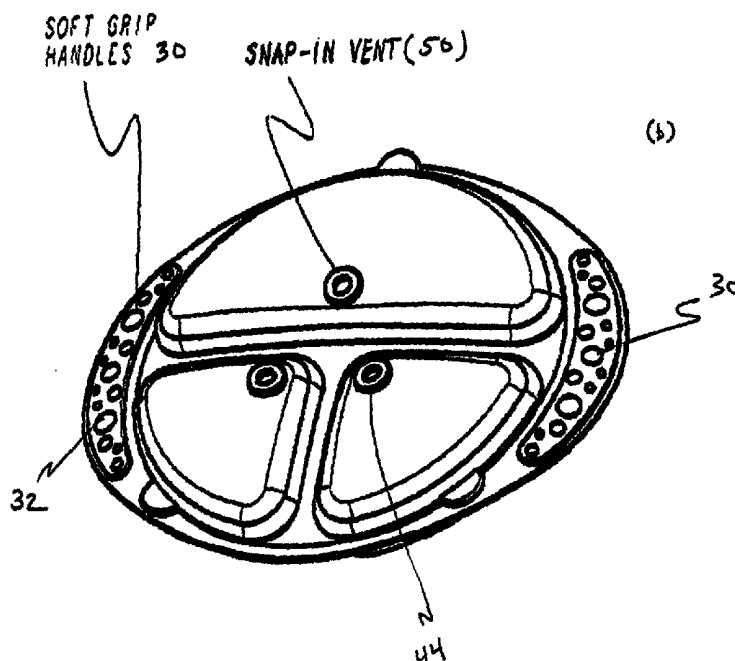

(57) Abstract: Improved feeding dishes for children. The dishes are microwaveable containers such as plates or bowls having one or more lids thereon. The containers include pressure release opening such as vents for releasing pressure from the container while the dish is heated in a microwave. Automatic vents, which release pressure once the pressure releases a given level, and manual vents, which are opened and closed by the parent, are provide. Preferably, the containers are composites of soft and hard components.



WO 02/26087 A2

Feeding Dishes for Children

Inventor: Nouri E. Hakim Monroe, Louisiana

Related Applications

The present application claims the priority of U.S. Provisional Application Serial No. 60/235,072 filed September 25, 2000, which is fully incorporated herein by reference.

Field of the Invention

The present invention is directed to improved feeding dishes for children, such as feeding plates and bowls.

Background of the Invention

Frequently, parents wish to heat up food for small children. One convenient way to do so is to place the food in a feeding dish and to heat the food in a microwave. However, if the food is heated without a top, the food (and/or any liquid in the dish) can splatter, making a mess on the inside of the microwave.

An alternative is to heat the food with the lid only partially covering the dish, so as to prevent the problem of splattering. Yet, this is not an entirely satisfactory method either. Heating is somewhat inefficient using this method and some splattering may still occur due to the gap between the lid and the dish.

Furthermore, securely attaching the top to the dish is also relatively undesirable. Steam and heat can build up within the dish while heating. When the parent removes the top, that steam and heat may be quickly released. If the parent is not careful or if the child is nearby, the child can be exposed to this quick release of heat and steam when the top is removed.

Accordingly, there is a need in the art for improved feeding dishes which allow quick and relatively efficient heating in the microwave while preventing splattering, and which reduce or eliminate the risk of scalding the child when the top is removed.

Summary of the Invention

It is an object of the present invention to provide improved feeding dishes and containers for children.

It is a further object to provide improved feeding dishes for children which can be efficiently microwaved without splattering.

It is a further object to provide improved feeding dishes for children which reduce the risk of releasing steam or heat into the child's face when the top is removed.

Further objects of the invention will become apparent in conjunction with the disclosure provided herein.

The present invention is directed to improved feeding dishes for children in the form of containers such as plates or bowls. The containers have components which allow pressure such as steam or other heat to be released from the container during heating.

In the preferred embodiment, the container includes a pressure release opening such as a vent, and is constructed of components which are suitable for being microwaved (and/or for being heated in an oven). In one embodiment, the vent automatically releases pressure from the container, once the pressure reaches a given level. In a further embodiment, the pressure vent can be opened and closed by a parent. This selective opening and closing allows the parent to control pressure release as desired. For example, the parent can leave the vent open while microwaving the food to allow pressure and steam to be released from the dish during the heating process. After

cooking the food, the vent can be closed to maintain the warmth of the food within the container.

In further preferred embodiments, the plates and bowls are composites of soft and hard components. For example, Kraton, silicone, TPE, or other flexible materials can be used for the soft components, and polypropylene or other rigid materials or rigid plastics can be used for the hard components.

The containers are also preferably suited for eating directly therefrom. They can be directly inserted into a microwave for heating their contents, and can also be used for storage of food in a refrigerator, or for travel.

Brief Description of the Drawings

Figure 1 is a series of views of a feeding container in accordance with the present invention, with Figure 1(a) being a top view thereof; figure 1(b) being a perspective view thereof; and figure 1(c) being a side view.

Figure 2 is a further series of views of a feeding container showing a vent mechanism, in accordance with the present invention, with Figure 2(a) being a top view of the feeding container; Figure 2(b) being a cross-sectional view of section 48 of Figure 2(c) showing a pressure vent in the feeding container; and Figure 2(c) is a side view of the feeding container. Figure 2(d) is a top view of the vent in Figures 2(a) - 2(c), with the slit in the closed position. Figure 2(e) is a top view of the vent in Figures 2(a) - 2(c), with the slit in the open position.

Figure 3 is a series of views of an additional or alternative embodiment of a feeding container, in accordance with the present invention, showing a vent mechanism in a lid handle. Figure 3(a) is a top view of the feeding container; Figure 3(b) is a cross-sectional view of the feeding container showing a pressure vent in the handle; and Figure 3(c) is a further cross-sectional view.

Figures 4(a) and 4(b) are perspective views of the feeding container of Figure 3.

Figure 5 is a series of views of an embodiment of the invention in which the lid handle has an integrated pressure vent, as follows:

Figure 5(a) is a front view of a lid handle having an integrated pressure vent.

Figure 5(b) is a front view of an insert or extension off of the container lid which serves as a holder for the lid handle.

Figure 5(c) is a front view of the handle of Figure 5(a) located within the insert of Figure 5(b), with the configuration of handle and insert being in the open vent position.

Figure 5(d) is a front view of the handle of Figure 5(a) located within the insert of Figure 5(b), with the configuration of handle and insert being in the closed vent position.

Figure 5(e) is a bottom view of the lid handle of Figure 5(a).

Figure 5(f) is a top view of the insert of Figure 5(b).

Figure 5(g) is a cross sectional view of the handle of Figure 5(a) located within the insert of Figure 5(b), with the configuration of handle and insert being in the open vent position, viewed from the bottom of the assembly.

Figure 5(h) is a cross sectional view of the handle of Figure 5(a) located within the insert of Figure 5(b), with the configuration of handle and insert being in the closed vent position, viewed from the top of the assembly.

Figure 5(i) is a back view of the configuration shown in Figure 5(d), with the handle and insert being in the closed vent position.

Figure 5(j) is a side view of the handle and insert showing a locking mechanism to lock the handle into a given configuration (whether an open or closed vent position).

Figure 6 are views of a further embodiment of the invention, a travel bowl with a flat lid. Figure 6(a) is a top view of the travel bowl; Figure 6(b) is a cross sectional view of the bowl of Figure 6(a); and Figure 6(c) is an enlargement of the vent of Figure 6(a) and 6(b).

Detailed Description of the Invention and the Preferred Embodiments

In accordance with the present invention, a feeding container is provided for feeding young children as shown in Figure 1. The bottom portion of feeding tray 10 is a plate 20. Plate 20 can be a regular plate or a sectional plate, i.e. a plate with multiple compartments. In one embodiment, as shown in the figures, plate 20 includes three compartments. Any number of compartments of any desired sizes, however, can be provided consistent with the invention.

Plate 20 is covered by one or more lids. In a preferred embodiment, as shown in the figures, a separate lid is provided for each compartment. As shown in Figure 1(a), a large snap on lid 22 and small snap on lids 24 and 26 are used to cover individual compartments of the plate. Any configuration of sizes can be provided. Preferably, one lid is provided for each compartment, although a lid can be provided for more than one compartment if desired. For example, a single lid can be used to cover all of the plate's compartments at once, or two lids can be provided (one for a large compartment, and then a second lid provided for two smaller compartments), or so forth.

The use of multiple lids allows a parent to feed a child from each individual compartment by removing the lid from that one compartment, while the other lids remain attached. Thus, while the child is being fed from that one compartment, the lids attached to the other compartments keep the food in those other compartments warm. In addition, should the child knock the plate over, the waste of food is minimized to spillage from a single compartment only, since the other lids remain attached to the plate. Preferably, the lids are snap-on lids, with a tab 28 provided to each lid to pull the lid off of the plate.

In accordance with the invention, the container also has one or more pressure release vents therein. In the preferred embodiment, each of the lids of the plate (or each of the compartments) has a pressure vent. One such pressure vent 50 is shown in Figures 1 and 2, although any other desired vent can be used as well.

The pressure vent 50 is provided so that the plate can be warmed safely in a microwave while the lid is attached to the tray. This vent prevents the container from exploding in the microwave, and prevents excessive pressure from being released into the child (or parent's) face when the lid is removed. An automatic vent can be used (which releases pressure when it rises to a given level), or a manual vent can be used (which is opened and closed by the parent). An example of an automatic vent is vent 50 as shown in Figures 1 and 2; an example of a manual vent is vent 90 in lid handle 100, as shown in Figures 3-5. The vent can be located anywhere on the container. Preferably, it is located on the lid, whether in a corner, on an edge, or in any other desired location.

In one preferred embodiment of an automatic vent, vent 50 consists of a ring 44 which is snapped onto each of the lids 22, 24 and 26, as shown in Figures 2(a) - 2(e). For example, as shown in Figure 2(b), a first component, such as a lower gasket or soft seal 54 (e.g. TPE) is inserted into a hole in the lid, or molded as part of the lid. An elastic membrane 40 is placed onto the gasket or seal 54. The ring 44 is then snapped onto or otherwise adhered to the gasket 54 and membrane 40, sandwiching the membrane 40 between the ring 44 and the gasket 54.

With particular reference to the top views shown in Figures 2(d) - 2(e), the elastic membrane 40 consists of a circular sheet of flexible material. This flexible material or membrane 40 has a slit 42 through it. Normally, the slit 42 is closed, i.e. the edges of the slit are pressed against each other so that the vent is in the closed position, as shown in Figure 2(d). When pressure builds up within the container, i.e. below the membranes shown in Figures 2(d)-2(e), it pushes or flexes the membrane outward (away from the container). The edges of the membrane are fixed by the ring, so the center flexes upward, forcing the slit 42 open, as shown in Figure 2(e). When slit 42 opens, pressure is released from the container.

Once pressure is released from the container, the membrane returns to its original closed position, as shown in Figure 2(d). (Since the pressure has been released, it is no longer high enough

to press the membrane outward enough to open the vent). Thus, vent 50 automatically opens to release pressure when the pressure rises sufficiently, and also automatically closes itself when the pressure sufficiently drops.

In summary, when a plate of food is heated in the microwave, pressure can build up in each of the compartments of the container of the invention. When the pressure in the container or a section thereof builds to a predetermined level, the pressure is released through the vent in the lid. As pressure builds, the membrane flexes upward, stretching the slit to open it. This opening of the slit releases any of the pressure built up underneath. Thus, the plate will not explode, as can happen when a tightly sealed food tray is microwaved for too long.

Various shaped membranes can be used consistent with the invention. For example, in one embodiment the membrane is concave, pressing the edges of the slit against each other and closing the slit as shown by configuration 46 in Figure 2(b). This membrane sits inside the ring, as discussed above. However, non-concave membranes can be used as well, and the interior ring 44 can be in a shape other than cylindrical, with the ring non-circular, if desired.

Likewise, any other automatic vent configuration can also be used consistent with the invention, the configuration of Figure 2 being shown as merely one preferred embodiment. Some other examples of vents which respond to changes in pressure are shown in PCT Application Serial No. PCT/US98/17379 filed August 21, 1998 (International Publication No. WO 99/08578), and PCT Application Serial No. PCT/US99/19238 filed August 20, 1999 (International Publication No. WO 00/10434), both of which are incorporated herein by reference.

Moreover, manual vent configurations can also be used. For example, a hole can be provided in the lid of a container with a small snap on cover covering that hole (the cover being attached to the lid, or separate from it). The parent removes the small cover from the hole to release pressure (before or after microwaving the food) and replaces the small cover once the compartment

has been vented. The cover can be attached via a strap to the lid so that it is not lost when removed. Alternately, a turning manual vent can be provided as shown in Figures 3-5.

Similarly, many other automatic and manual vents are known in the art and can be used with the current containers.

In accordance with the preferred embodiments of the invention (as with the vent of Figures 2 and 5), the lid remains attached to the plate while excess pressure is vented. Thus, explosions are eliminated, but the lid is always affixed to the tray while heating and thereafter. This speeds up the heating process and assists in preserving the food warm until the parent removes the lid from the tray. Additionally, since the lid is affixed to the compartment, food or liquid will not splatter out of the container and make a mess within the microwave. Moreover, once the excess pressure has been released, the elastic membrane reverts to the closed position, preventing loss of heat from the container.

Further in accordance with preferred embodiments of the invention, the feeding dishes include both relatively soft and relatively hard components, as shown in the figures. For example, soft grip handles 30 are provided on the top of the plate on the hard handles, as shown in Figures 1 - 4. These soft handles present a better gripping surface than a hard plastic, and preferably also have raised (or indented) bumps or ridges 32 which further assist in gripping the handles. A strip of soft material can be affixed to the handle, by any desired means. For example, it can be adhered with adhesive, or, the soft material can be molded onto the top of the handle and protrude into the handle (or through the cross section of the hard handle), or so forth.

In an additional or alternate embodiment, a soft no-slide or slide resistant base 36 is provided on the hard bottom of the container to prevent skidding of the plate across a table surface, as shown in Figure 4. All of the feeding containers of the present invention preferably include such a two component base. The bottoms of the containers are constructed of a hard material (e.g.

polypropylene), but preferably have no-slide components inserted onto the base (preferably soft materials, such as Kraton, or so forth). For example, one or more soft rings 34 can be provided to the hard base, as shown in Figures 1(c), 2(c) and 3(c). These rings prevent the feeding containers from sliding over the surface of a table or other surface such as the baby's high chair. The rings can be uniform, have a scalloped edge, etc. These soft rings 34 can also be affixed by adhesive, by molding, or by any other desired means, as discussed with the soft handle above.

While the top of the handle and the bottom of the base are preferably soft, other components of the invention (e.g. the plate) are preferably made of harder materials to facilitate cleaning food particles therefrom. In one preferred embodiment, the softer components are made of Kraton while the harder components are made of polypropylene. In other embodiments, other soft components such as silicone, TPE, or so forth can also be used, and other hard components such as other rigid plastics can be used, all consistent with the invention.

In a further embodiment of the invention, a feeding bowl is provided as shown in Figures 3 through 5. Feeding bowl 80 includes a bowl 82 and a domed lid 84. The construction of the feeding bowl is similar to that of the feeding plate described above, and likewise includes a pressure valve therein.

In a preferred embodiment of the feeding bowl, however, the pressure valve is incorporated in a lid handle, as also shown in Figures 3 through 5. When the tray is inserted into a microwave, the handle is turned to open a vent in the lid of the bowl, allowing pressure to escape from the bowl during heating. Once the bowl is removed from the microwave, the handle is turned to close the vent and preserve the heat in the container. Although an automatic pressure valve with a slit is preferred for the plate, and a manual vent in a handle is preferred for the domed lid bowl, it will be understood, of course, that either vent could be utilized with either embodiment.

As shown in Figure 5, in the preferred embodiment of the feeding bowl, manual vent is

located in a lid handle 100. Lid handle 100 includes a knob 102 attached to a cylinder 106. Cylinder 106 includes a recessed channel 108 therein.

As shown in Figure 3, the feeding bowl's lid includes an insert piece or handle holder 118 at the top of the lid. Insert piece or handle holder 118 (preferably cylindrical) is an extension off of the lid of the container, which is provided for the lid handle to be inserted therein. Preferably, this extension off the lid or insert piece 118 is integrally molded with the lid as a single piece. In other words, the top of the lid has an indentation 116, and rising out of this indentation 116 is the handle holder, extension or insert 118. The indentation 116 provides a space around the lid handle 100, between the handle and the lid 84, for a parent's fingers to turn the handle. However, instead of rising off of an indentation 116, insert 118 can also rise up off of a flat top of the lid 84, or off of a flat lid for a bowl.

As shown in Figure 5(a) - 5(d), cylinder 106 of lid handle 100 inserts into the cylindrical insert piece 118 of lid 84. Cylindrical insert 118 includes a lid channel or cut-out 120. Lid channel or cut-out 120, shown in Figures 5(b) and 5(f), is the shape which results after a rectangular (or trapezoidal) section of the cylindrical insert piece 118 has been cut lengthwise down part of the height of the cylinder, through the circumference, and has been removed from the insert 118. In other words, a strip of material is removed from one side of the cylinder to form the lid channel or cut-out 120 shown in Figures 5(b) and 5(f). The removal of this strip forms a space in the cylindrical insert 118, such as that between two prongs of a fork. Of course, this description is merely provided for illustration purposes; a section of the insert 118 does not need to be actually cut to provide the cut out or channel 120, since the insert 118 can be merely molded into this shape to begin with. Likewise, any other shaped channel can also be provided consistent with the invention.

Lid channel or cut out 120 extends from the top of the cylindrical insert piece 118, down

part of the length of that insert piece. A corresponding cut out or channel is provided in lid handle 100. This corresponding cut out is handle channel 108 shown in Figure 5(a). In contrast to the lid channel 120 which extends top to bottom, handle channel 108 extends bottom to top. In other words, handle channel 108 extends from the bottom of the lid handle up part of the length of cylinder 106 of the handle 100. (Alternately, these configurations of the channel 108 and the channel 120 could be reversed).

After inserting lid handle 100 into insert 118, lid handle 100 can be rotated within the cylindrical insert 118 by rotating knob 102.

When rotated to the open position, channel 108 of lid handle 100 overlaps with channel 120 of cylindrical insert 118 of the lid. As a result, air can flow from the container, into the bottom of cylinder 106, into the channel 108, and out through channel 120 to exit the bowl, as shown in the front view of Figure 5(c) and the cross sectional view of Figure 5(g).

When rotated to the closed position, channel 108 of lid handle 100 overlaps with the solid portion of the cylindrical insert 118, i.e. solid section 130 of the circumference shown in Figure 5(h). As a result, air flowing through the channel 108 is blocked by section 130 of the circumference of the insert piece 118. Section 130 is any solid section along the circumference, i.e. any section other than cut out 120. Since section 130 covers the channel 108 along much of its length and seals off the top portion of channel 108, it closes off the channel 108 such that air cannot flow out of the bowl. This closed vent configuration is shown in the front view of Figure 5(d), the cross sectional view of Figure 5(h), and the back view of Figure 5(i). While these views show the channel 108 offset 180 degrees from the channel 120, it will be understood that the channel 108 can be offset, of course, by a lesser rotation as well, the channel 108 being closed so long as it does not overlap with the channel 120 or so long as the top of the channel 108 is covered.

In summary, the lid includes a channel (cut out 120), and the lid handle includes a

corresponding channel 108. The handle can be rotated such that the two channels overlap, to release pressure from inside the container. Or, the handle can be rotated such that they do not overlap, to retain pressure and heat within the container.

In an additional embodiment, as shown in figure 5(j), it is further preferred that a “locking” mechanism be provided to the handle, i.e. a mechanism for holding the handle somewhat securely in a given configuration, whether in the open vent or closed vent position. As shown in the figure, a bump or protuberance 140 is preferably provided off of lid handle 100 (e.g. off of knob 102). This bump 140 can be rotated into an indentation 150 or 154 in the top of the insert 118. The top surface 152 between indentations 150 and 154 is lower than the top surface 156 of solid section 130 of insert 118. As a result, the bump can be rotated between indentations 150 and 154, but not further in either direction.

When the bump 140 is rotated into indentation 150, the lid handle is in the open vent position; when the bump 140 is rotated into indentation 154, the lid handle is in the closed vent position. For illustration purposes, a spacing between indentations 150 and 154 is shown wherein the open and closed vent positions are offset by an arc of less than 180 degrees, although a greater or lesser spacing and arc can be used, as desired.

A further embodiment, showing a travel bowl with a flat lid, is shown in Figure 6. This embodiment is similar to the embodiments of the invention described above. Bowl 160 includes a flat lid 168 having a manual vent 170. Manual vent 170 is similar to vent 50 of Figure 2, and includes a membrane 180. Membrane 180 is a slightly modified shape from membrane 40. This membrane can be used for the other containers discussed above, and reflects a further preferred embodiment. Like vent 50, vent 170 includes a slit in membrane 180. Pressure within the container causes expansion of the membrane 180, stretching open the slit to release the built up pressure from the container.

Although the present invention has been described with respect to the preferred embodiments of feeding dishes and bowls, they can be used with other food containers as well. Having described this invention with regard to specific embodiments, it is to be understood that the description is not meant as a limitation since further embodiments, modifications and variations may be apparent or may suggest themselves to those skilled in the art. It is intended that the present application cover all such embodiments, modifications and variations.

Claims

What is claimed is:

1. A feeding dish for children, comprising:
a container, said container comprising a pressure release opening therein.
2. A feeding dish as claimed in claim 1, wherein said dish is constructed of microwaveable components.
3. A feeding dish as claimed in claim 1, wherein said pressure release opening is an automatic vent.
4. A feeding dish as claimed in claim 1, wherein said pressure release opening is a manual vent.
5. A feeding dish as claimed in claim 1, wherein said pressure release opening comprises a flexible material, said flexible material comprising a slit.
6. A feeding dish as claimed in claim 1, wherein dish comprises a handle, and said pressure release opening is located in said handle.
7. A feeding dish as claimed in claim 1, wherein said dish further comprises a lid and a handle.
8. A feeding dish as claimed in claim 1, wherein said pressure release opening comprises at least two channels, said pressure release opening having an open position wherein said channels overlap and a closed position wherein said channels do not overlap.
9. A feeding dish as claimed in claim 8, wherein said dish comprises a lid and a handle, and wherein said two channels comprise a channel in said lid and a channel in said handle.
10. A feeding dish as claimed in claim 3, wherein said automatic vent opens at a predetermined pressure level, and closes below said predetermined pressure level.
11. A feeding dish as claimed in claim 1, wherein said dish is a plate.
12. A feeding dish as claimed in claim 1, wherein said dish is a bowl.
13. A feeding dish as claimed in claim 1, wherein said dish comprises a lid.

14. A feeding dish as claimed in claim 12, wherein said bowl has a domed lid.
15. A feeding dish as claimed in claim 13, wherein said lid is a snap-on lid.
16. A feeding dish as claimed in claim 1, wherein said feeding dish comprises a lid, and wherein said pressure release opening is a vent in said lid.
17. A feeding dish as claimed in claim 1, wherein said dish comprises compartments.
18. A feeding dish as claimed in claim 17, wherein each of said compartments has a lid.
19. A feeding dish as claimed in claim 17, wherein each of said compartments comprises at least one of said pressure release openings.
20. A feeding dish as claimed in claim 17, wherein each of said compartments has a lid.
21. A feeding dish as claimed in claim 17, wherein said dish comprises a lid for each of said compartments, and wherein each of said lids comprises at least one of said pressure release openings.
22. A feeding dish as claimed in claim 1, wherein said dish is constructed of soft and hard components.
23. A feeding dish as claimed in claim 1, wherein said dish includes a soft grip handle.
24. A feeding dish as claimed in claim 1, wherein said dish includes a soft, slide-resistant base.
25. A feeding dish as claimed in claim 22, wherein said soft components are selected from the group consisting of: Kraton, silicone, and TPE.
26. A feeding dish as claimed in claim 22, wherein hard components comprise a rigid plastic.
27. A feeding dish as claimed in claim 1, wherein said dish comprises a handle comprising said pressure release opening, and wherein said handle has a locking mechanism.
28. A feeding dish as claimed in claim 1, wherein said dish comprises a lid comprising a handle, wherein said handle comprises a protuberance and said lid comprises an indentation, such that said protuberance extends into said indentation as a locking mechanism.

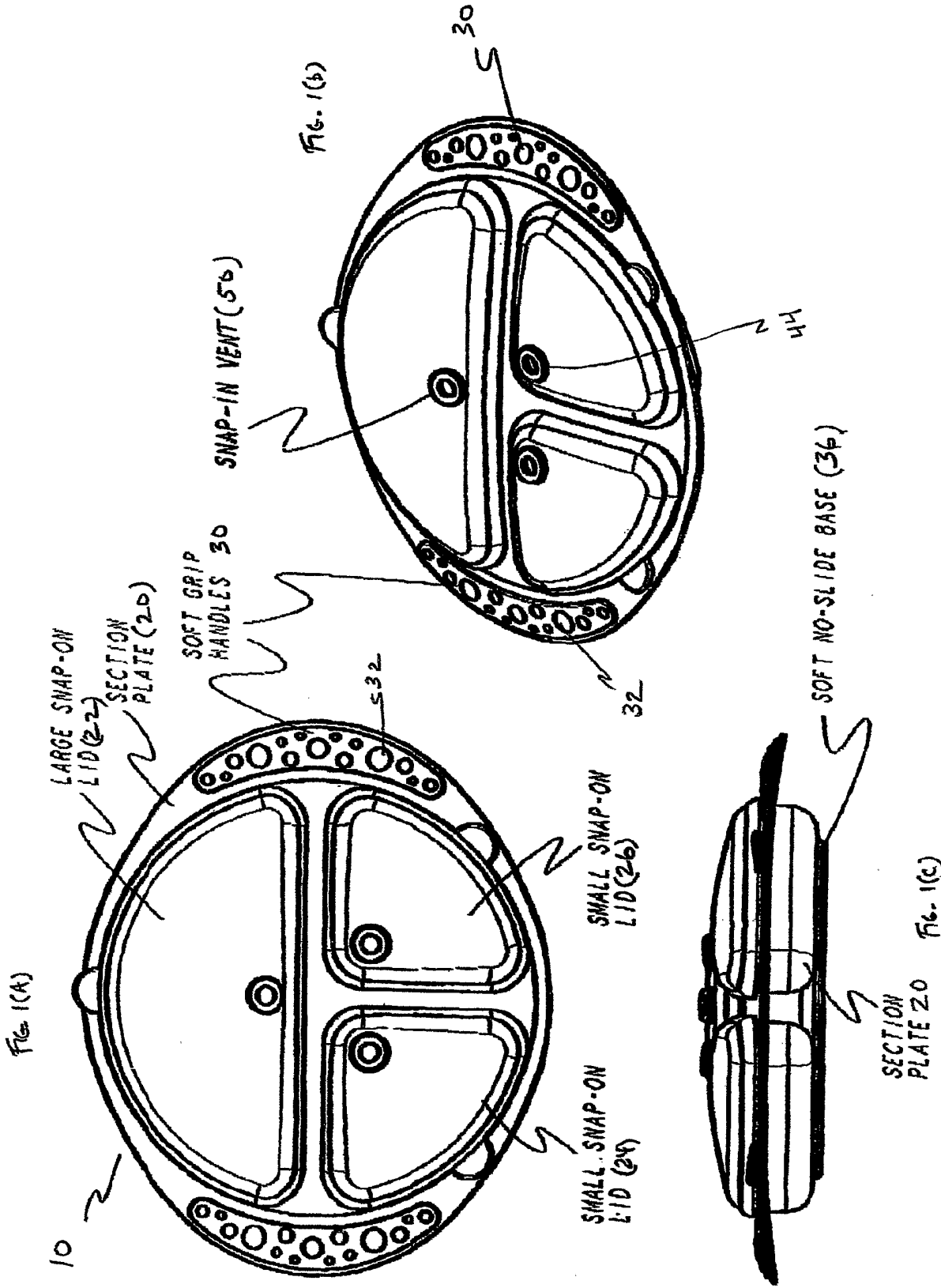

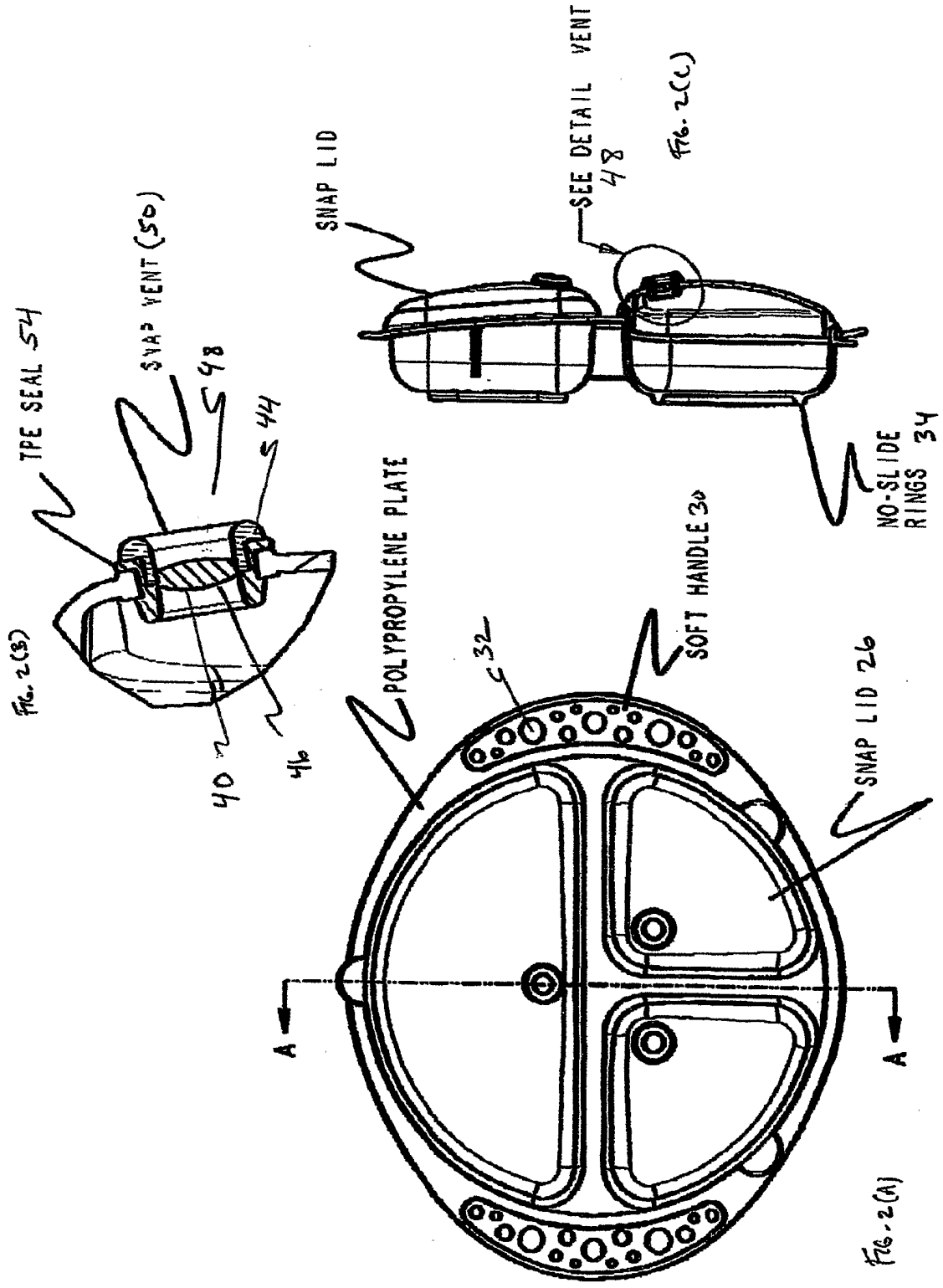
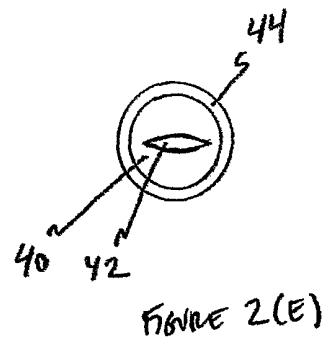
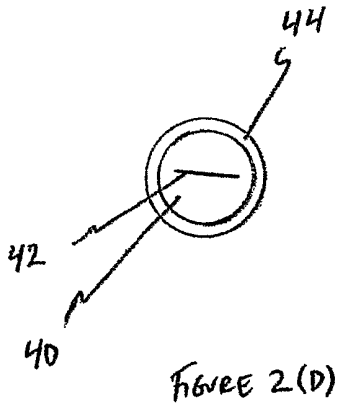

FIGURE 2



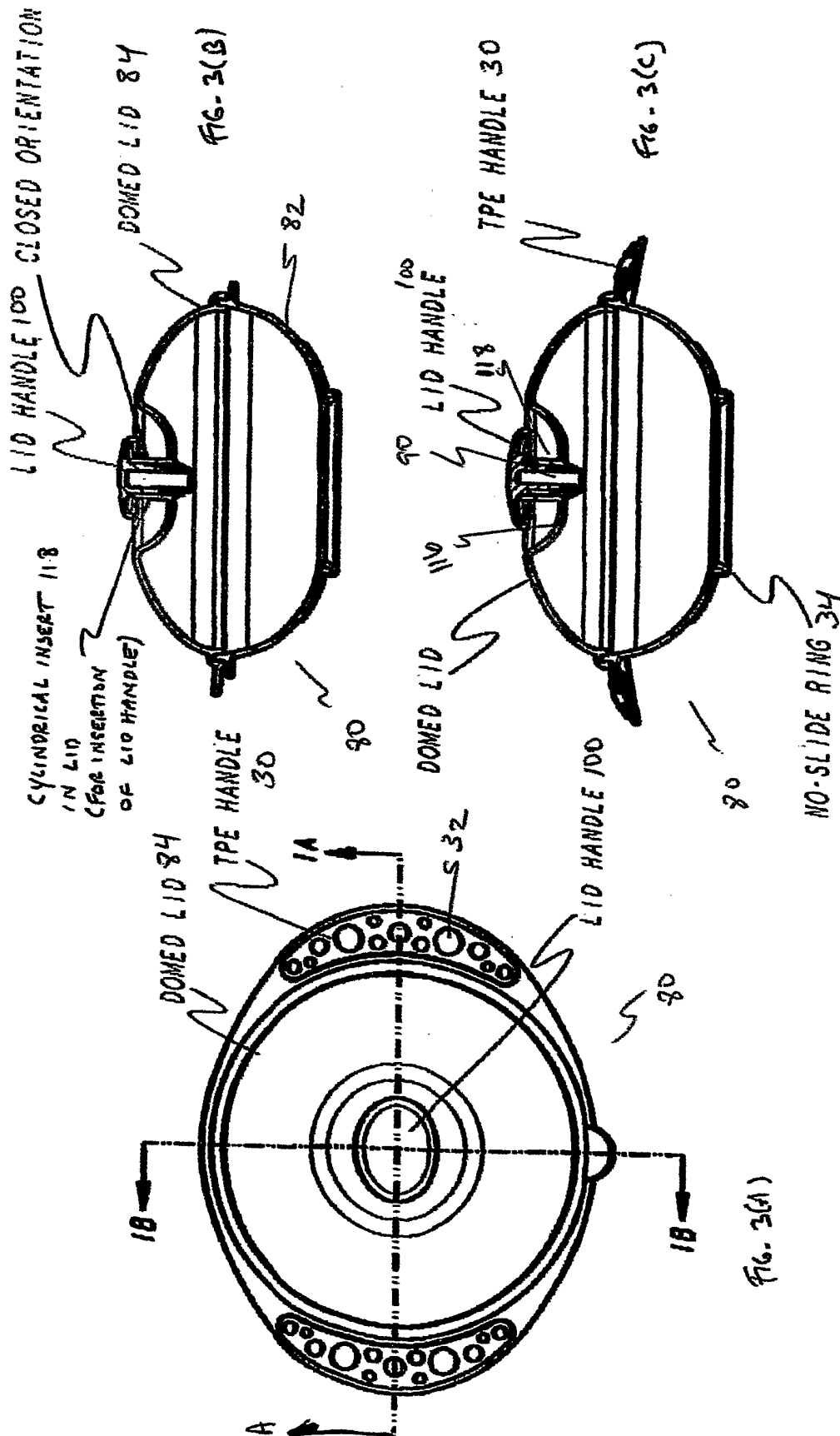

FIGURE 3

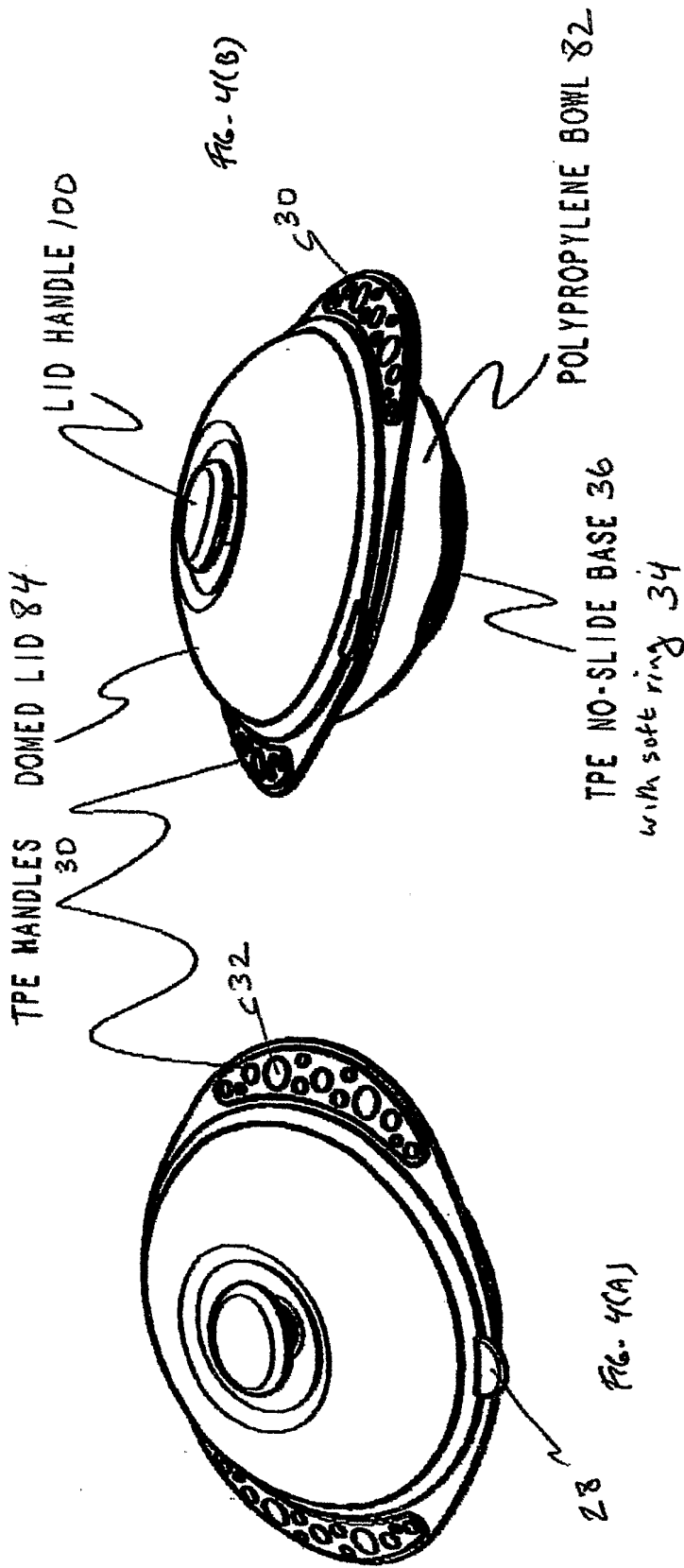

FIGURE 4

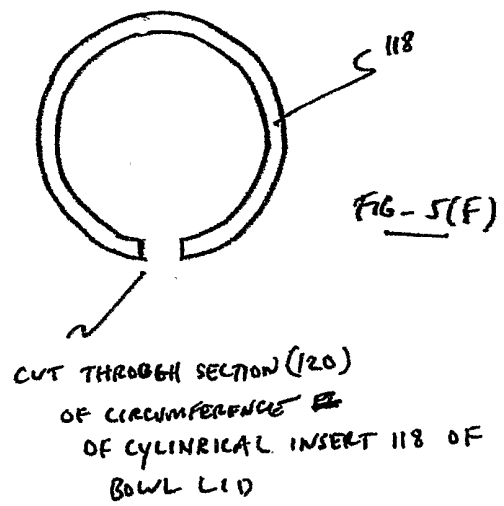
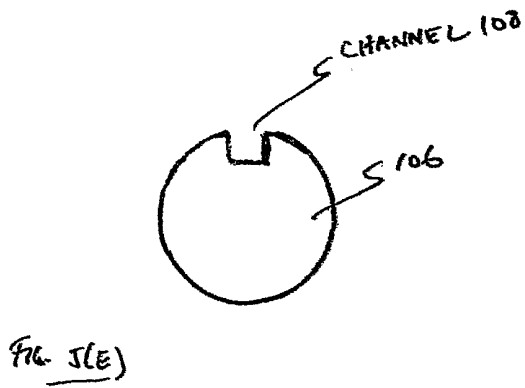
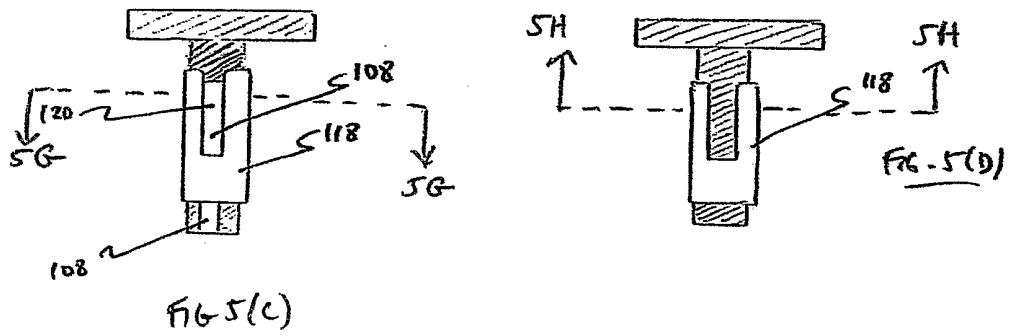
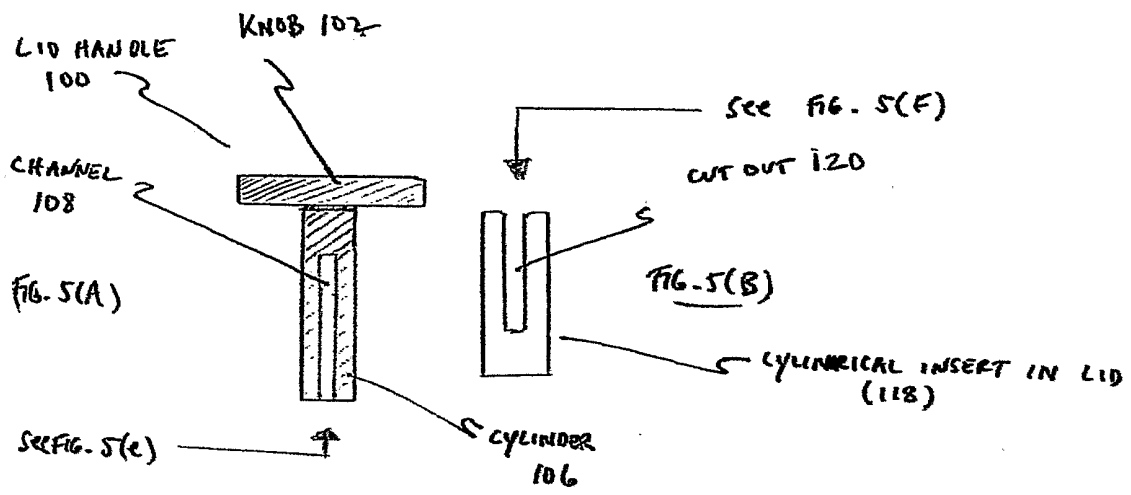

FIGURE 5

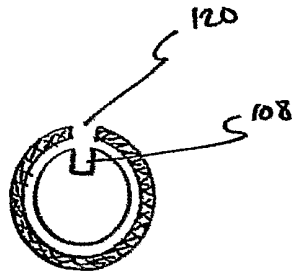

FIG. 5(G)
(OPEN VALVE)

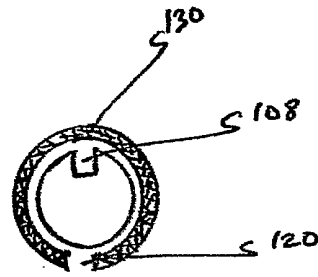

FIG. 5(H)
(CLOSED VALVE)

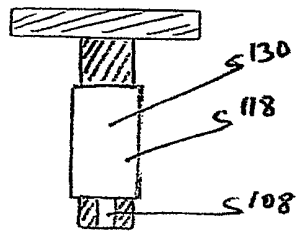

FIG. 5(I)

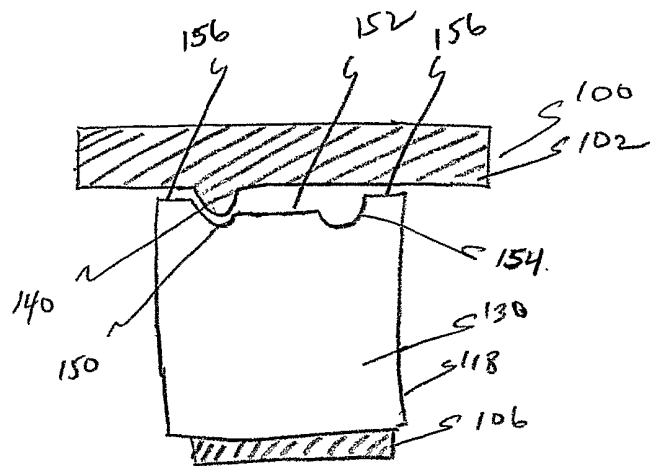

FIGURE 5(j)

