



INTERNATIONAL APPLICATION PUBLISHED UNDER THE PATENT COOPERATION TREATY (PCT)

<p>(51) International Patent Classification ⁷ : C11D</p>	<p>A2</p>	<p>(11) International Publication Number: WO 00/15741</p> <p>(43) International Publication Date: 23 March 2000 (23.03.00)</p>
<p>(21) International Application Number: PCT/US99/20482</p> <p>(22) International Filing Date: 10 September 1999 (10.09.99)</p> <p>(30) Priority Data: Not furnished 11 September 1998 (11.09.98) US</p> <p>(71) Applicant: COLGATE-PALMOLIVE COMPANY [US/US]; 300 Park Avenue, New York, NY 10022 (US).</p> <p>(72) Inventors: DURBUT, Patrick; 25, avenue des Villas, B-4800 Verviers (BE). BROZE, Guy; 2, rue des Enfants, B-4460 Grace-Hollogne (BE).</p> <p>(74) Agent: NANFELDT, Richard, E.; Colgate-Palmolive Com- pany, 909 River Road, P.O. Box 1343, Piscataway, NJ 08855-1343 (US).</p>		<p>(81) Designated States: AE, AL, AM, AT, AU, AZ, BA, BB, BG, BR, BY, CA, CH, CN, CR, CU, CZ, DE, DK, DM, EE, ES, FI, GB, GD, GE, GH, GM, HR, HU, ID, IL, IN, IS, JP, KE, KG, KP, KR, KZ, LC, LK, LR, LS, LT, LU, LV, MD, MG, MK, MN, MW, MX, NO, NZ, PL, PT, RO, RU, SD, SE, SG, SI, SK, SL, TJ, TM, TR, TT, UA, UG, UZ, VN, YU, ZA, ZW, ARIPO patent (GH, GM, KE, LS, MW, SD, SL, SZ, UG, ZW), Eurasian patent (AM, AZ, BY, KG, KZ, MD, RU, TJ, TM), European patent (AT, BE, CH, CY, DE, DK, ES, FI, FR, GB, GR, IE, IT, LU, MC, NL, PT, SE), OAPI patent (BF, BJ, CF, CG, CI, CM, GA, GN, GW, ML, MR, NE, SN, TD, TG).</p> <p>Published <i>Without international search report and to be republished upon receipt of that report.</i></p>
<p>(54) Title: LIQUID CLEANING COMPOSITIONS</p> <p>(57) Abstract</p> <p>All purpose cleaning or microemulsion compositions contain an anionic surfactant, zwitterionic surfactant, a fatty acid having C₃ to C₂₂ carbon atoms, a foam control agent, and water.</p>		

FOR THE PURPOSES OF INFORMATION ONLY

Codes used to identify States party to the PCT on the front pages of pamphlets publishing international applications under the PCT.

AL	Albania	ES	Spain	LS	Lesotho	SI	Slovenia
AM	Armenia	FI	Finland	LT	Lithuania	SK	Slovakia
AT	Austria	FR	France	LU	Luxembourg	SN	Senegal
AU	Australia	GA	Gabon	LV	Latvia	SZ	Swaziland
AZ	Azerbaijan	GB	United Kingdom	MC	Monaco	TD	Chad
BA	Bosnia and Herzegovina	GE	Georgia	MD	Republic of Moldova	TG	Togo
BB	Barbados	GH	Ghana	MG	Madagascar	TJ	Tajikistan
BE	Belgium	GN	Guinea	MK	The former Yugoslav Republic of Macedonia	TM	Turkmenistan
BF	Burkina Faso	GR	Greece	ML	Mali	TR	Turkey
BG	Bulgaria	HU	Hungary	MN	Mongolia	TT	Trinidad and Tobago
BJ	Benin	IE	Ireland	MR	Mauritania	UA	Ukraine
BR	Brazil	IL	Israel	MW	Malawi	UG	Uganda
BY	Belarus	IS	Iceland	MX	Mexico	US	United States of America
CA	Canada	IT	Italy	NE	Niger	UZ	Uzbekistan
CF	Central African Republic	JP	Japan	NL	Netherlands	VN	Viet Nam
CG	Congo	KE	Kenya	NO	Norway	YU	Yugoslavia
CH	Switzerland	KG	Kyrgyzstan	NZ	New Zealand	ZW	Zimbabwe
CI	Côte d'Ivoire	KP	Democratic People's Republic of Korea	PL	Poland		
CM	Cameroon	KR	Republic of Korea	PT	Portugal		
CN	China	KZ	Kazakstan	RO	Romania		
CU	Cuba	LC	Saint Lucia	RU	Russian Federation		
CZ	Czech Republic	LI	Liechtenstein	SD	Sudan		
DE	Germany	LK	Sri Lanka	SE	Sweden		
DK	Denmark	LR	Liberia	SG	Singapore		
EE	Estonia						

LIQUID CLEANING COMPOSITIONS

5

Field of the Invention

The present invention relates to an all purpose hard surface cleaning or microemulsion composition having improved foam profile properties.

Background of the Invention

10 This invention relates to an improved all-purpose liquid cleaner which can be in the form of a microemulsion designed in particular for cleaning hard surfaces and which is effective in removing grease soil and/or bath soil and in leaving unrinsed surfaces with a shiny appearance as well as having improved profile foam properties.

In recent years all-purpose liquid detergents have become widely accepted for
15 cleaning hard surfaces, e.g., painted woodwork and panels, tiled walls, wash bowls, bathtubs, linoleum or tile floors, washable wall paper, etc.. Such all-purpose liquids comprise clear and opaque aqueous mixtures of water-soluble synthetic organic detergents and water-soluble detergent builder salts. In order to achieve comparable cleaning efficiency with granular or powdered all-purpose cleaning compositions, use
20 of water-soluble inorganic phosphate builder salts was favored in the prior art all-purpose liquids. For example, such early phosphate-containing compositions are described in U.S. Patent Nos. 2,560,839; 3,234,138; 3,350,319; and British Patent No. 1,223,739.

In view of the environmentalist's efforts to reduce phosphate levels in ground
25 water, improved all-purpose liquids containing reduced concentrations of inorganic phosphate builder salts or non-phosphate builder salts have appeared. A particularly useful self-opacified liquid of the latter type is described in U.S. Patent No. 4,244,840.

However, these prior art all-purpose liquid detergents containing detergent builder salts or other equivalent tend to leave films, spots or streaks on cleaned

unrinsed surfaces, particularly shiny surfaces. Thus, such liquids require thorough rinsing of the cleaned surfaces which is a time-consuming chore for the user.

In order to overcome the foregoing disadvantage of the prior art all-purpose liquid, U.S. Patent No. 4,017,409 teaches that a mixture of paraffin sulfonate and a
5 reduced concentration of inorganic phosphate builder salt should be employed. However, such compositions are not completely acceptable from an environmental point of view based upon the phosphate content. On the other hand, another alternative to achieving phosphate-free all-purpose liquids has been to use a major proportion of a mixture of anionic and nonionic detergents with minor amounts of glycol
10 ether solvent and organic amine as shown in U.S. Patent No. 3,935,130. Again, this approach has not been completely satisfactory and the high levels of organic detergents necessary to achieve cleaning cause foaming which, in turn, leads to the need for thorough rinsing which has been found to be undesirable to today's consumers.

15 Another approach to formulating hard surfaced or all-purpose liquid detergent composition where product homogeneity and clarity are important considerations involves the formation of oil-in-water (o/w) microemulsions which contain one or more surface-active detergent compounds, a water-immiscible solvent (typically a hydrocarbon solvent), water and a "cosurfactant" compound which provides product
20 stability. By definition, an o/w microemulsion is a spontaneously forming colloidal dispersion of "oil" phase particles having a particle size in the range of 25 to 800 Å in a continuous aqueous phase.

In view of the extremely fine particle size of the dispersed oil phase particles, microemulsions are transparent to light and are clear and usually highly stable against
25 phase separation.

Patent disclosures relating to use of grease-removal solvents in o/w microemulsions include, for example, European Patent Applications EP 0137615 and EP 0137616 - Herbots et al; European Patent Application EP 0160762 - Johnston et al;

and U.S. Patent No. 4,561,991 - Herbots et al. Each of these patent disclosures also teaches using at least 5% by weight of grease-removal solvent.

It also is known from British Patent Application GB 2144763A to Herbots et al, published March 13, 1985, that magnesium salts enhance grease-removal
5 performance of organic grease-removal solvents, such as the terpenes, in o/w microemulsion liquid detergent compositions. The compositions of this invention described by Herbots et al. require at least 5% of the mixture of grease-removal solvent and magnesium salt and preferably at least 5% of solvent (which may be a mixture of water-immiscible non-polar solvent with a sparingly soluble slightly polar
10 solvent) and at least 0.1% magnesium salt.

However, since the amount of water immiscible and sparingly soluble components which can be present in an o/w microemulsion, with low total active ingredients without impairing the stability of the microemulsion is rather limited (for example, up to 18% by weight of the aqueous phase), the presence of such high
15 quantities of grease-removal solvent tend to reduce the total amount of greasy or oily soils which can be taken up by and into the microemulsion without causing phase separation.

The following representative prior art patents also relate to liquid detergent cleaning compositions in the form of o/w microemulsions: U.S. Patents Nos. 4,472,291
20 - Rosario; 4,540,448 - Gauteer et al; 3,723,330 - Sheflin; etc.

Liquid detergent compositions which include terpenes, such as d-limonene, or other grease-removal solvent, although not disclosed to be in the form of o/w microemulsions, are the subject matter of the following representative patent documents: European Patent Application 0080749; British Patent Specification
25 1,603,047; and U.S. Patents 4,414,128; and 4,540,505. For example, U.S. Patent No. 4,414,128 broadly discloses an aqueous liquid detergent composition characterized by, by weight:

(a) from 1% to 20% of a synthetic anionic, nonionic, amphoteric or zwitterionic surfactant or mixture thereof;

(b) from 0.5% to 10% of a mono- or sesquiterpene or mixture thereof, at a weight ratio of (a):(b) being in the range of 5:1 to 1:3; and

(c) from 0.5% to 10% of a polar solvent having a solubility in water at 15°C in the range of from 0.2% to 10%. Other ingredients present in the formulations disclosed in this patent include from 0.05% to 2% by weight of an alkali metal, ammonium or alkanolammonium soap of a C₁₃-C₂₄ fatty acid; a calcium sequestrant from 0.5% to 13% by weight; non-aqueous solvent, e.g., alcohols and glycol ethers, up to 10% by weight; and hydrotropes, e.g., urea, ethanolamines, salts of lower alkylaryl sulfonates, up to 10% by weight. All of the formulations shown in the Examples of this patent include relatively large amounts of detergent builder salts which are detrimental to surface shine.

A pH neutral microemulsion composition based on paraffin sulfonate and ethoxylated nonionic surfactant is able to deliver improved grease cleaning versus built, alkaline compositions. Besides the improved grease cleaning, this approach is much safer to surfaces as well as less aggressive on consumer's hands (Loth et al - U.S. Patent 5,075,026).

The microemulsion technology provides outstanding oil uptake capacity because of the adjustment of the curvature of the surfactant micelles by the molecules of the cosurfactant. Rod-like micelles are preferred as they can "swallow" oil to become globular without increasing the surface of contact between the hydrophobic core of the micelle and the hydrophilic continuous phase.

In diluted usage however, the microemulsion state is usually lost and the cleaning performance relies on the adsorption efficacy and leaving character of the surfactant system. Nonionic surfactants perform very well on grease, as they are excellent grease "solubilizers". Actually, they spontaneously form swollen micelles. In moderate climate countries such as the northern states of the United States and the northern countries of Europe, the soil on the hard surfaces contains a major proportion of greasy materials. It is accordingly not surprising that the anionic-nonionic surfactant based microemulsion is so efficient in those countries. In hot weather countries

however, the amount of particulate soils is more important (as doors and windows remain open) and the classical microemulsion (U.S. Patent 5,075,026) shows weaknesses on this type of soil which is a mixed grease-particulate soil in nature.

The instant invention teaches that the foam profile properties of an all purpose cleaning or microemulsion compositions can be improved by the addition of a foam control system.

Summary of the Invention

The present invention provides an improved, clear, liquid cleaning composition having improved foam profile properties and interfacial tension which improves cleaning hard surfaces such as plastic, vitreous and metal surfaces having a shiny finish, oil stained floors, automotive engines and other engines as well as having improved foam collapse properties. More particularly, the improved cleaning compositions exhibit good grease soil removal properties due to the improved interfacial tensions, and leave the cleaned surfaces shiny without the need of or requiring only minimal additional rinsing or wiping. The latter characteristic is evidenced by little or no visible residues on the unrinsed cleaned surfaces and, accordingly, overcomes one of the disadvantages of prior art products.

Surprisingly, these desirable results are accomplished even in the absence of polyphosphate or other inorganic or organic detergent builder salts and also in the complete absence or substantially complete absence of grease-removal solvent.

In one aspect, the invention generally provides a stable, clear all-purpose, hard surface cleaning composition having improved foam profile properties which is especially effective in the removal of oily and greasy oil. The cleaning composition includes, on a weight basis:

about 0.25 to about 20 wt. %, more preferably about 0.5 to about 15 wt. % of an anionic surfactant.

0.25% to 5% of a zwitterionic surfactant;

0.25% to about 4%, more preferably 0.5% to 3% of the foam control agent;

0 to about 15% of magnesium sulfate heptahydrate;

about 0 to about 10.0% of a perfume, essential oil or water insoluble hydrocarbon;

about 0.05 to about 2%, more preferably 0.1% to 1% of a fatty acid having 8 to 22 carbon atoms; and

5 the balance being water, said proportions being based upon the total weight of the composition.

The cleaning composition can be in the form of a microemulsion in which case the concentration of the water mixable cosurfactant is about 0 to 50.0 wt. %, preferably 1 wt. % to about 20 wt. % and the concentration of the perfume, essential oil or water
10 insoluble hydrocarbon is about 0.4 wt. % to about 10.0 wt. %.

Detailed Description of the Invention

The present invention relates to a stable all purpose cleaning or microemulsion composition comprising approximately by weight: 0.25% to 20% of an anionic surfactant, 0.25% to 5% of a zwitterionic surfactant, 0 to 50% of a cosurfactant, 0.25%
15 to 4% of a foam control agent, 0.05% to 2% of a fatty acid having 8 to 22 carbon atoms, 0 to 10% of a water insoluble hydrocarbon or a perfume and the balance being water. The instant compositions excluded the use of polyhydroxy fatty acid amides, ethoxylated or ethoxylated/propoxylated nonionic surfactants formed from the
20 condensation of a primary alkanol and ethylene oxide or ethylene oxide and propylene oxide because the use of these surfactants reduce the effectiveness of the foam control agent. The instant compositions exclude the use of grease release agents such as

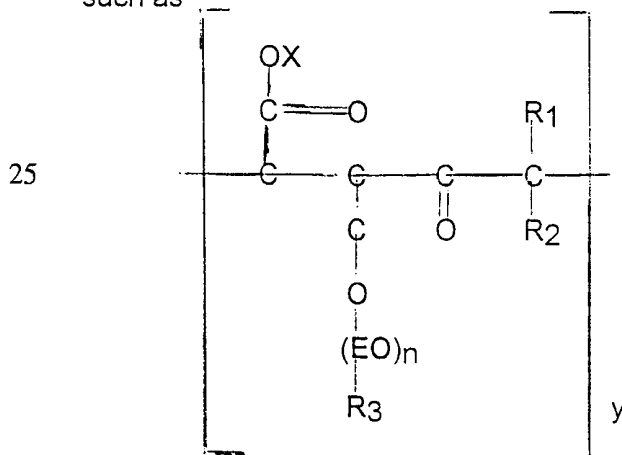

wherein X is hydrogen or an alkali metal cation and n is a number from 2 to 16, R₁ is selected from the group consisting of methyl or hydrogen, R₂ is a C₁ to C₁₂ linear or branched chained alkyl group and R₃ is a C₂ to C₁₆ linear or branched chained alkyl group and y is of such value as to provide a molecular weight about 5,000 to about
5 15,000 or a polyethylene glycol. The cleaning composition can be in the form of a microemulsion in which case the concentration of the water mixable cosurfactant is about 0 to about 50.0 wt. %, preferably about 0.1 wt. % to about 25.0 wt. % and the concentration of the perfume, essential oil or water insoluble hydrocarbon is about 0.4 wt. % to about 10.0 wt. %.

10 According to the present invention, the role of the hydrocarbon can be provided by a non-water-soluble perfume. Typically, in aqueous based compositions the presence of a solubilizers, such as alkali metal lower alkyl aryl sulfonate hydrotrope, triethanolamine, urea, etc., is required for perfume dissolution, especially at perfume levels of 1% and higher, since perfumes are generally a mixture of fragrant essential
15 oils and aromatic compounds which are generally not water-soluble. Therefore, by incorporating the perfume into the aqueous cleaning composition as the oil (hydrocarbon) phase of the microemulsion composition, several different important advantages are achieved.

First, the cosmetic properties of the ultimate cleaning composition are improved:
20 the compositions are both clear (as a consequence of the formation of a microemulsion) and highly fragranced (as a consequence of the perfume level).

Second, the need for use of solubilizers, which do not contribute to cleaning performance, is eliminated.

Third, an improved grease release effect and an improved grease removal
25 capacity in neat (undiluted) usage of the dilute aspect or after dilution of the concentrate can be obtained without detergent builders or buffers or conventional grease removal solvents at neutral or acidic pH and at low levels of active ingredients while improved cleaning performance can also be achieved in diluted usage.

As used herein and in the appended claims the term "perfume" is used in its ordinary sense to refer to and include any non-water soluble fragrant substance or mixture of substances including natural (i.e., obtained by extraction of flower, herb, blossom or plant), artificial (i.e., mixture of natural oils or oil constituents) and
5 synthetically produced substance) odoriferous substances. Typically, perfumes are complex mixtures of blends of various organic compounds such as alcohols, aldehydes, ethers, aromatic compounds and varying amounts of essential oils (e.g., terpenes) such as from 0% to 80%, usually from 10% to 70% by weight. The essential
10 oils themselves are volatile odoriferous compounds and also serve to dissolve the other components of the perfume.

In the present invention the precise composition of the perfume is of no particular consequence to cleaning performance so long as it meets the criteria of water immiscibility and having a pleasing odor. Naturally, of course, especially for cleaning compositions intended for use in the home, the perfume, as well as all other
15 ingredients, should be cosmetically acceptable, i.e., non-toxic, hypoallergenic, etc.

The hydrocarbon such as a perfume is present in the hard surface cleaning composition in an amount of from 0 to 10% by weight, preferably 0.4% to 10% by weight and most preferably from 0.4% to 3.0% by weight, especially preferably from 0.5% to 2.0% by weight. If the hydrocarbon (perfume) is added in amounts more than
20 10% by weight, the cost is increased without any additional cleaning benefit and, in fact, with some diminishing of cleaning performance insofar as the total amount of greasy or oily soil which can be taken up in the oil phase of the microemulsion will decrease proportionately.

Furthermore, although superior grease removal performance will be achieved
25 for perfume compositions not containing any terpene solvents, it is apparently difficult for perfumers to formulate sufficiently inexpensive perfume compositions for products of this type (i.e., very cost sensitive consumer-type products) which includes less than 20%, usually less than 30%, of such terpene solvents.

Thus, merely as a practical matter, based on economic consideration, the microemulsion compositions of the present invention may often include as much as 0.2% to 7% by weight, based on the total composition, of terpene solvents introduced thereunto via the perfume component. However, even when the amount of terpene solvent in the cleaning formulation is less than 1.5% by weight, such as up to 0.6% by weight or 0.4% by weight or less, satisfactory grease removal and oil removal capacity is provided by the inventive diluted microemulsions.

Thus, for a typical formulation of a diluted microemulsion according to this invention a 20 milliliter sample of microemulsion containing 1% by weight of perfume will be able to solubilize, for example, up to 2 to 3 ml of greasy and/or oily soil, while retaining its form as a microemulsion, regardless of whether the perfume contains 0%, 0.1%, 0.2%, 0.3%, 0.4%, 0.5%, 0.6%, 0.7% or 0.8% by weight of terpene solvent.

In place of the perfume one can employ a water insoluble essential oil, or water insoluble saturated or unsaturated organic compound having 6 to 18 carbon at a concentration of 0 to 8.0 wt. %, preferably 0.4 to 8.0 wt. percent, more preferably 0.4 to 3.0 wt. %.

The water insoluble saturated or unsaturated organic compounds contain 4 to 20 carbon atoms and up to 4 different or identical functional groups and is used at a concentration of about 1.0 wt. % to about 8 wt. %, more preferably about 2.0 wt. % to about 7 wt. %. Examples of acceptable water insoluble saturated or unsaturated organic compound include (but are not limited to) water insoluble hydrocarbons containing 0 to 4 different or identical functional groups, water insoluble aromatic hydrocarbons containing 0 to 4 different or identical functional groups, water insoluble heterocyclic compounds containing 0 to 4 different or identical functional groups, water insoluble ethers containing 0 to 3 different or identical functional groups, water insoluble alcohols containing 0 to 3 different or identical functional groups, water insoluble amines containing 0 to 3 different or identical functional groups, water insoluble esters containing 0 to 3 different or identical functional groups, water insoluble carboxylic acids containing 0 to 3 different or identical functional groups,

water insoluble amides containing 0 to 3 different or identical functional groups, water insoluble nitriles containing 0 to 3 different or identical functional group, water insoluble aldehydes containing 0 to 3 different or identical functional groups, water insoluble ketones containing 0 to 3 different or identical functional groups, water insoluble phenols containing 0 to 3 different or identical functional groups, water insoluble nitro compounds containing 0 to 3 different or identical functional groups, water insoluble halogens containing 0 to 3 different or identical functional groups, water insoluble sulfates or sulfonates containing 0 to 3 different or identical functional groups, limonene, dipentene, terpineol, essential oils, perfumes, water insoluble organic compounds containing up to 4 different or identical functional groups such as an alkyl cyclohexane having both three hydroxys and one ester group and mixture thereof.

Typical heterocyclic compounds are 2,5-dimethylhydrofuran, 2-methyl-1,3-dioxolane, 2-ethyl 2-methyl 1,3 dioxolane, 3-ethyl 4-propyl tetrahydropyran, 3-morpholino-1,2-propanediol and N-isopropyl morpholine. A typical amine is alpha-methyl benzyl dimethylamine. Typical halogens are 4-bromotoluene, butyl chloroform and methyl perchloropropane. Typical hydrocarbons are 1,3-dimethylcyclohexane, cyclohexyl-1 decane, methyl-3 cyclohexyl-9 nonane, methyl-3 cyclohexyl-6 nonane, dimethyl cycloheptane, trimethyl cyclopentane, ethyl-2 isopropyl-4 cyclohexane. Typical aromatic hydrocarbons are bromotoluene, diethyl benzene, cyclohexyl bromoxylene, ethyl-3 pentyl-4 toluene, tetrahydronaphthalene, nitrobenzene and methyl naphthalene. Typical water insoluble esters are benzyl acetate, dicyclopentadienylacetate, isononyl acetate, isobornyl acetate and isobutyl isobutyrate. Typical water insoluble ethers are di(alpha-methyl benzyl) ether and diphenyl ether. Typical alcohols are phenoxyethanol and 3-morpholino-1,2-propanediol. Typical water insoluble nitro derivatives are nitro butane and nitrobenzene.

Suitable essential oils are selected from the group consisting of:

Anethole 20/21 natural, Aniseed oil china star, Aniseed oil globe brand, Balsam (Peru), Basil oil (India), Black pepper oil, Black pepper oleoresin 40/20, Bois de Rose (Brazil)

FOB, Borneol Flakes (China), Camphor oil, White, Camphor powder synthetic technical, Cananga oil (Java), Cardamom oil, Cassia oil (China), Cedarwood oil (China) BP, Cinnamon bark oil, Cinnamon leaf oil, Citronella oil, Clove bud oil, Clove leaf, Coriander (Russia), Coumarin 69°C (China), Cyclamen Aldehyde, Diphenyl oxide, 5 Ethyl vanilin, Eucalyptol, Eucalyptus oil, Eucalyptus citriodora, Fennel oil, Geranium oil, Ginger oil, Ginger oleoresin (India), White grapefruit oil, Guaiacwood oil, Gurjun balsam, Heliotropin, Isobornyl acetate, Isolongifolene, Juniper berry oil, L-methyl acetate, Lavender oil, Lemon oil, Lemongrass oil, Lime oil distilled, Litsea Cubeba oil, Longifolene, Menthol crystals, Methyl cedryl ketone, Methyl chavicol, Methyl salicylate, 10 Musk ambrette, Musk ketone, Musk xylol, Nutmeg oil, Orange oil, Patchouli oil, Peppermint oil, Phenyl ethyl alcohol, Pimento berry oil, Pimento leaf oil, Rosalin, Sandalwood oil, Sandenol, Sage oil, Clary sage, Sassafras oil, Spearmint oil, Spike lavender, Tagetes, Tea tree oil, Vanilin, Vetyver oil (Java), Wintergreen, Allocimene, Arbanex™, Arbanol®, Bergamot oils, Camphene, Alpha-Campholenic aldehyde, I- 15 Carvone, Cineoles, Citral, Citronellol Terpenes, Alpha-Citronellol, Citronellyl Acetate, Citronellyl Nitrile, Para-Cymene, Dihydroanethole, Dihydrocarveol, d-Dihydrocarvone, Dihydrolinalool, Dihydromyrcene, Dihydromyrcenol, Dihydromyrcenyl Acetate, Dihydroterpineol, Dimethyloctanal, Dimethyloctanol, Dimethyloctanyl Acetate, Estragole, Ethyl-2 Methylbutyrate, Fenchol, Fernlol™, Florilys™, Geraniol, Geranyl 20 Acetate, Geranyl Nitrile, Glidmint™ Mint oils, Glidox™, Grapefruit oils, trans-2-Hexenal, trans-2-Hexenol, cis-3-Hexenyl Isovalerate, cis-3-Hexanyl-2-methylbutyrate, Hexyl Isovalerate, Hexyl-2-methylbutyrate, Hydroxycitronellal, Ionone, Isobornyl Methylether, Linalool, Linalool Oxide, Linalyl Acetate, Menthane Hydroperoxide, I-Methyl Acetate, Methyl Hexyl Ether, Methyl-2-methylbutyrate, 2-Methylbutyl 25 Isovalerate, Myrcene, Nerol, Neryl Acetate, 3-Octanol, 3-Octyl Acetate, Phenyl Ethyl-2-methylbutyrate, Petitgrain oil, cis-Pinane, Pinane Hydroperoxide, Pinanol, Pine Ester, Pine Needle oils, Pine oil, alpha-Pinene, beta-Pinene, alpha-Pinene Oxide, Plinol, Plinyl Acetate, Pseudo Ionone, Rhodinol, Rhodinyl Acetate, Spice oils, alpha-Terpinene, gamma-Terpinene, Terpinene-4-OL, Terpeneol, Terpinolene, Terpinyl

Acetate. Tetrahydrolinalool, Tetrahydrolinalyl Acetate, Tetrahydromyrcenol, Tetralol[®], Tomato oils, Vitalizair, Zestoral[™].

Suitable water-soluble non-soap, anionic surfactants include those surface-active or detergent compounds which contain an organic hydrophobic group containing generally 8 to 26 carbon atoms and preferably 10 to 18 carbon atoms in their molecular structure and at least one water-solubilizing group selected from the group of sulfonate, sulfate and carboxylate so as to form a water-soluble detergent. Usually, the hydrophobic group will include or comprise a C₈-C₂₂ alkyl, alkyl or acyl group. Such surfactants are employed in the form of water-soluble salts and the salt-forming cation usually is selected from the group consisting of sodium, potassium, ammonium, magnesium and mono-, di- or tri-C₂-C₃ alkanolammonium, with the sodium, magnesium and ammonium cations again being preferred.

Examples of suitable sulfonated anionic surfactants are the well known higher alkyl mononuclear aromatic sulfonates such as the higher alkyl benzene sulfonates containing from 10 to 16 carbon atoms in the higher alkyl group in a straight or branched chain, C₈-C₁₅ alkyl toluene sulfonates and C₈-C₁₅ alkyl phenol sulfonates.

A preferred sulfonate is linear alkyl benzene sulfonate having a high content of 3- (or higher) phenyl isomers and a correspondingly low content (well below 50%) of 2- (or lower) phenyl isomers, that is, wherein the benzene ring is preferably attached in large part at the 3 or higher (for example, 4, 5, 6 or 7) position of the alkyl group and the content of the isomers in which the benzene ring is attached in the 2 or 1 position is correspondingly low. Particularly preferred materials are set forth in U.S. Patent 3,320,174.

Other suitable anionic surfactants are the olefin sulfonates, including long-chain alkene sulfonates, long-chain hydroxyalkane sulfonates or mixtures of alkene sulfonates and hydroxyalkane sulfonates. These olefin sulfonate detergents may be prepared in a known manner by the reaction of sulfur trioxide (SO₃) with long-chain olefins containing 8 to 25, preferably 12 to 21 carbon atoms and having the formula RCH=CHR₁ where R is a higher alkyl group of 6 to 23 carbons and R₁ is an alkyl

group of 1 to 17 carbons or hydrogen to form a mixture of sultones and alkene sulfonic acids which is then treated to convert the sultones to sulfonates. Preferred olefin sulfonates contain from 14 to 16 carbon atoms in the R alkyl group and are obtained by sulfonating an α -olefin.

5 Other examples of suitable anionic sulfonate surfactants are the paraffin sulfonates containing 10 to 20, preferably 13 to 17, carbon atoms. Primary paraffin sulfonates are made by reacting long-chain α olefins and bisulfites and paraffin sulfonates having the sulfonate group distributed along the paraffin chain are shown in U.S. Patents Nos. 2,503,280; 2,507,088; 3,260,744; 3,372,188; and German Patent
10 735,096.

Examples of satisfactory anionic sulfate surfactants are the C₈-C₁₈ alkyl sulfate salts and the C₈-C₁₈ alkyl ether polyethenoxy sulfate salts having the formula R(OC₂H₄)_n OSO₃M wherein n is 1 to 12, preferably 1 to 5, and M is a solubilizing cation selected from the group consisting of sodium,
15 potassium, ammonium, magnesium and mono-, di- and triethanol ammonium ions. The alkyl sulfates may be obtained by sulfating the alcohols obtained by reducing glycerides of coconut oil or tallow or mixtures thereof and neutralizing the resultant product.

On the other hand, the alkyl ether polyethenoxy sulfates are obtained by
20 sulfating the condensation product of ethylene oxide with a C₈-C₁₈ alkanol and neutralizing the resultant product. The alkyl sulfates may be obtained by sulfating the alcohols obtained by reducing glycerides of coconut oil or tallow or mixtures thereof and neutralizing the resultant product. On the other hand, the alkyl ether polyethenoxy sulfates are obtained by sulfating the condensation product of ethylene oxide with a
25 C₈-C₁₈ alkanol and neutralizing the resultant product. The alkyl ether polyethenoxy sulfates differ from one another in the number of moles of ethylene oxide reacted with one mole of alkanol. Preferred alkyl sulfates and preferred alkyl ether polyethenoxy sulfates contain 10 to 16 carbon atoms in the alkyl group.

The C₈-C₁₂ alkylphenyl ether polyethenoxy sulfates containing from 2 to 6 moles of ethylene oxide in the molecule also are suitable for use in the inventive compositions. These surfactants can be prepared by reacting an alkyl phenol with 2 to 6 moles of ethylene oxide and sulfating and neutralizing the resultant ethoxylated
5 alkylphenol.

Other suitable anionic detergents are the C₉-C₁₅ alkyl ether polyethenoxy carboxylates having the structural formula R(OC₂H₄)_nOX COOH wherein n is a number from 4 to 12, preferably 5 to 10 and X is selected from the group consisting of CH₂, C(O)R₁ and

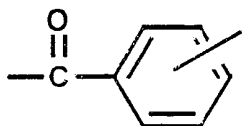

10

wherein R₁ is a C₁-C₃ alkylene group. Preferred compounds include C₉-C₁₁ alkyl ether polyethenoxy (7-9) C(O) CH₂CH₂COOH, C₁₃-C₁₅ alkyl ether polyethenoxy (7-9)

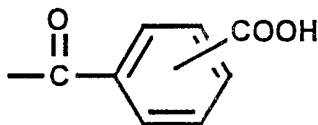

15

and C₁₀-C₁₂ alkyl ether polyethenoxy (5-7) CH₂COOH. These compounds may be prepared by condensing ethylene oxide with appropriate alkanol and reacting this reaction product with chloracetic acid to make the ether carboxylic acids as shown in US Pat. No. 3,741,911 or with succinic anhydride or phthalic anhydride.

20

Obviously, these anionic detergents will be present either in acid form or salt form depending upon the pH of the final composition, with the salt forming cation being the same as for the other anionic detergents.

Of the foregoing non-soap anionic surfactants, the preferred surfactants are the C₉-C₁₅ linear alkylbenzene sulfonates and the C₁₃-C₁₇ paraffin or alkane sulfonates. Particularly, preferred compounds are sodium C₁₀-C₁₃ alkylbenzene sulfonate and sodium C₁₃-C₁₇ alkane sulfonate.

25

The water-soluble zwitterionic surfactant, which is also an essential ingredient of present liquid detergent composition, constitutes 0.25 to 5%, preferably 0.5% to 4%, by weight and provides good foaming properties and mildness to the present nonionic

based liquid detergent. The zwitterionic surfactant is a water soluble betaine having the general formula:

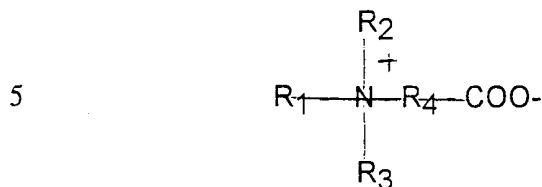

wherein R₁ is an alkyl group having 10 to 20 carbon atoms, preferably 12 to 16 carbon atoms, or the amido radical:

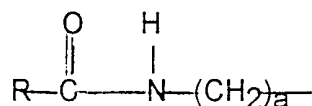

wherein R is an alkyl group having 9 to 19 carbon atoms and a is the integer 1 to 4; R₂ and R₃ are each alkyl groups having 1 to 3 carbons and preferably 1 carbon; R₄ is an alkylene or hydroxyalkylene group having from 1 to 4 carbon atoms and, optionally, one hydroxyl group. Typical alkyldimethyl betaines include decyl dimethyl betaine or 2-(N-decyl-N, N-dimethyl-ammonia) acetate, coco dimethyl betaine or 2-(N-coco N, N-dimethylammonio) acetate, myristyl dimethyl betaine, palmityl dimethyl betaine, lauryl diemethyl betaine, cetyl dimethyl betaine, stearyl dimethyl betaine, etc. The amidobetaines similarly include cocoamidoethylbetaine, cocoamidopropyl betaine and the like. A preferred betaine is coco (C₈-C₁₈) amidopropyl dimethyl betaine.

The foam control system used in instant compositions comprises the synergistic combination of a fatty acid having about 8 to about 22 carbon atoms and a foam control agent.

Examples of the fatty acids which can be used as such or in the form of soap, mention can be made of distilled coconut oil fatty acids, "mixed vegetable" type fatty acids (e.g. high percent of saturated, mono-and/or polyunsaturated C₁₈ chains); oleic acid, stearic acid, palmitic acid, eicosanoic acid, and the like, generally those fatty acids having from 8 to 22 carbon atoms being acceptable.

The foam control agent employed in the instant invention are used as a means of either reducing initial foaming or destabilizing the resultant foam so that a maximum

decrease in foaming can be achieved within a specified time. The foaming agents are selected from the group consisting of organic mono esters, organic diesters and C₈-C₁₂ organic diols. Specific foam control agents are isohexyl neopentanoate, PEG-8 distearate, PEG-12 distearate, isopropyl myristate, myreth-3-myristate, laureth-
 5 2(ethylhexanoate), 1,8-octane diol, and 1,10-decane diol.

The organic monoesters are depicted by the formula

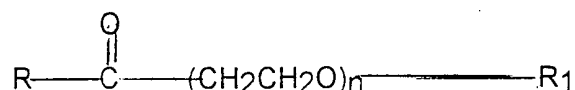

wherein R₁ is a C₃ to C₁₆, preferably C₈ to C₁₄ group, n is a number from 0 to 12,
 10 preferably 1 to 10, and R is selected from the group consisting of a C₃ to C₁₅, preferably C₈ to C₁₄ alkyl group, R₂R₃CH alkyl group wherein R₂ is a C₂ to C₆ alkyl group and R₃ is a C₄ to C₁₂ alkyl group, and R₄R₅H alkyl group wherein R₄ is hydrogen or a C₁ to C₄ alkyl group and R₅ is hydrogen or a C₁ to C₄ alkyl group. The organic diesters are depicted by the formula

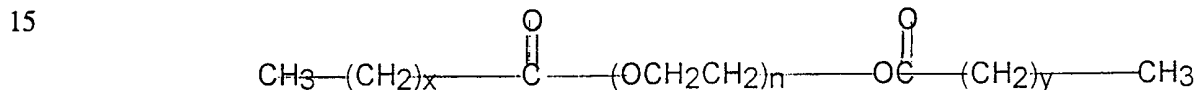

wherein x + y is from 10 to 40, preferably 12 to 36 and n is a number from 2 to 20.

A cosurfactant can be optionally used in forming the microemulsion composition. Three major classes of compounds have been found to provide highly suitable
 20 cosurfactants over temperature ranges extending from 4°C to 43°C for instance; (1) water-soluble C₃-C₄ alkanols, polypropylene glycol of the formula HO(CH₂CH(CH₃)O)_nH wherein n is a number from 2 to 18 and copolymers of ethylene oxide and propylene oxide and mono C₁-C₆ alkyl ethers and esters of ethylene glycol and propylene glycol having the structural formulas R(X)_nOH and R₁(X)_nOH wherein
 25 R is C₁-C₆ alkyl, R₁ is C₂-C₄ acyl group, X is (OCH₂CH₂) or (OCH₂(CH₃)CH) and n is a number from 1 to 4; (2) aliphatic mono- and di-carboxylic acids containing 2 to 10 carbon atoms, preferably 3 to 6 carbons in the molecule; and (3) triethyl phosphate. Additionally, mixtures of two or more of the three classes of cosurfactant compounds may be employed where specific pH's are desired.

When the mono- and di-carboxylic acid (Class 2) cosurfactants are employed in the instant microemulsion compositions at a concentration of 2 to 10 wt. %, the microemulsion compositions can be used as a cleaners for bathtubs and other hard surfaced items, which are acid resistant thereby removing lime scale, soap scum and greasy soil from the surfaces of such items damaging such surfaces. If these surfaces are of zirconium white enamel, they can be damaged by these compositions.

An aminoalkylene phosphoric acid at a concentration of 0.01 to 0.2 wt. % can be optionally used in conjunction with the mono- and di-carboxylic acids, wherein the aminoalkylene phosphoric acid helps prevent damage to zirconium white enamel surfaces. Additionally, 0.05 to 1% of phosphoric acid can be used in the composition.

Representative members of the polypropylene glycol include dipropylene glycol and polypropylene glycol having a molecular weight of 200 to 1000, e.g., polypropylene glycol 400. Other satisfactory glycol ethers are ethylene glycol monobutyl ether (butyl cellosolve), diethylene glycol monobutyl ether (butyl carbitol), dipropylene glycol monomethyl ether, triethylene glycol monobutyl ether, mono, di, tri propylene glycol monobutyl ether, tetraethylene glycol monobutyl ether, propylene glycol tertiary butyl ether, ethylene glycol monoacetate and dipropylene glycol propionate.

Representative members of the aliphatic carboxylic acids include C₃-C₆ alkyl and alkenyl monobasic acids such as acrylic acid and propionic acid and dibasic acids such as glutaric acid and mixtures of glutaric acid with adipic acid and succinic acid, as well as mixtures of the foregoing acids.

While all of the aforementioned glycol ether compounds and acid compounds provide the described stability, the most preferred cosurfactant compounds of each type, on the basis of cost and cosmetic appearance (particularly odor), are diethylene glycol monobutyl ether and a mixture of adipic, glutaric and succinic acids, respectively. The ratio of acids in the foregoing mixture is not particularly critical and can be modified to provide the desired odor. Generally, to maximize water solubility of

the acid mixture glutaric acid, the most water-soluble of these three saturated aliphatic dibasic acids, will be used as the major component.

Generally, weight ratios of adipic acid: glutaric acid:succinic acid is 1-3:1-8:1-5, preferably 1-2:1-6:1-3, such as 1:1:1, 1:2:1, 2:2:1, 1:2:1.5, 1:2:2, 2:3:2, etc. can be used with equally good results.

Still other classes of cosurfactant compounds providing stable microemulsion compositions at low and elevated temperatures are the mono-, di- and triethyl esters of phosphoric acid such as triethyl phosphate.

The amount of cosurfactant which might be required to stabilize the microemulsion compositions will, of course, depend on such factors as the surface tension characteristics of the cosurfactant, the type and amounts of the analeptropic complex and perfumes, and the type and amounts of any other additional ingredients which may be present in the composition and which have an influence on the thermodynamic factors enumerated above. Generally, amounts of cosurfactant in the range of from 0 to 50 wt. %, preferably from 0.1 wt. % to 25 wt. %, especially preferably from 0.5 wt. % to 15 wt. %, by weight provide stable microemulsions for the above-described levels of primary surfactants and perfume and any other additional ingredients as described below.

As will be appreciated by the practitioner, the pH of the final microemulsion will be dependent upon the identity of the cosurfactant compound, with the choice of the cosurfactant being effected by cost and cosmetic properties, particularly odor. For example, microemulsion compositions which have a pH in the range of 1 to 10 may employ either the class 1 or the class 4 cosurfactant as the sole cosurfactant, but the pH range is reduced to 1 to 8.5 when the polyvalent metal salt is present. On the other hand, the class 2 cosurfactant can only be used as the sole cosurfactant where the product pH is below 3.2. However, where the acidic cosurfactants are employed in admixture with a glycol ether cosurfactant, compositions can be formulated at a substantially neutral pH (e.g., pH 7 ± 1.5 , preferably 7 ± 0.2).

The ability to formulate neutral and acidic products without builders which have grease removal capacities is a feature of the present invention because the prior art microemulsion formulations most usually are highly alkaline or highly built or both.

The final essential ingredient in the hard surface cleaning compositions having improved interfacial tension properties is water. The proportion of water in the hard surface cleaning compositions generally is in the range of 20 wt. % to 97 wt. %, preferably 70 wt. % to 97 wt. % of the usual diluted o/w microemulsion composition.

In addition to the above-described essential ingredients required for the formation of the all purpose hard surface cleaning compositions, the compositions of this invention may often and preferably do contain one or more additional ingredients which serve to improve overall product performance.

One such ingredient is an inorganic or organic salt of oxide of a multivalent metal cation, particularly Mg^{++} . The metal salt or oxide provides several benefits including improved cleaning performance in dilute usage, particularly in soft water areas, and minimized amounts of perfume required to obtain the microemulsion state. Magnesium sulfate, either anhydrous or hydrated (e.g., heptahydrate), is especially preferred as the magnesium salt. Good results also have been obtained with magnesium oxide, magnesium chloride, magnesium acetate, magnesium propionate and magnesium hydroxide. These magnesium salts can be used with formulations at neutral or acidic pH since magnesium hydroxide will not precipitate at these pH levels.

Although magnesium is the preferred multivalent metal from which the salts (inclusive of the oxide and hydroxide) are formed, other polyvalent metal ions also can be used provided that their salts are nontoxic and are soluble in the aqueous phase of the system at the desired pH level.

Thus, depending on such factors as the pH of the system, the nature of the complex and cosurfactant, as well as the availability and cost factors, other suitable polyvalent metal ions include aluminum, copper, nickel, iron, calcium, etc. It should be noted, for example, that with the preferred paraffin sulfonate anionic detergent calcium salts will precipitate and should not be used. It has also been found that the aluminum

salts work best at pH below 5 or when a low level, for example 1 weight percent, of citric acid is added to the composition which is designed to have a neutral pH.

Alternatively, the aluminum salt can be directly added as the citrate in such case. As the salt, the same general classes of anions as mentioned for the magnesium salts can
5 be used, such as halide (e.g., bromide, chloride), sulfate, nitrate, hydroxide, oxide, acetate, propionate, etc.

The proportion of the multivalent salt generally will be selected so that at the appropriate weight ratio between the anionic surfactant and the zwitterionic surfactant, amine oxide or alkylene carbonate to deliver desired performance from the complex in
10 terms of adsorption properties on grease surface, the physical stability of the total composition is kept, that can be impaired due to an increased hydrophobicity of the analephotropic complex in the presence of multivalent salt instead of alkali metal cation such as the sodium salt thereof. As a consequence, the proportion of the multivalent salt will be selected so that the added quantity will neutralize from 0.1 to 1.5
15 equivalents of the anionic surfactant, preferably 0.9 to 1.4 equivalents of the acid form of the anionic surfactant. At higher concentrations of anionic surfactant, the amount of multivalent salt will be in range of 0.5 to 1 equivalents per equivalent of anionic surfactant.

The all-purpose liquid cleaning or microemulsion composition of this invention
20 may, if desired, also contain other components either to provide additional effect or to make the product more attractive to the consumer. The following are mentioned by way of example: Colors or dyes in amounts up to 0.5% by weight; bactericides in amounts up to 1% by weight; preservatives or antioxidizing agents, such as formalin, 5-chloro-2-methyl-4-isothiazolin-3-one, 2,6-di-tert.butyl-p-cresol, etc., in amounts up to
25 2% by weight; and pH adjusting agents, such as sulfuric acid or sodium hydroxide, as needed. Furthermore, if opaque compositions are desired, up to 4% by weight of an opacifier may be added.

In final form, the all-purpose cleaning or clear microemulsions exhibit stability at reduced and increased temperatures. More specifically, such compositions remain

clear and stable in the range of 4°C to 50°C, especially 10°C to 43°C. Such compositions exhibit a pH in the acid or neutral range depending on intended end use. The liquids are readily pourable and exhibit a viscosity in the range of 6 to 60 milliPascal· Second (mPas.) as measured at 25°C. with a Brookfield RVT Viscometer
5 using a #1 spindle rotating at 20 RPM. Preferably, the viscosity is maintained in the range of 10 to 40 mPas.

The compositions are directly ready for use or can be diluted as desired and in either case no or only minimal rinsing is required and substantially no residue or streaks are left behind. Furthermore, because the compositions are free of detergent
10 builders such as alkali metal polyphosphates they are environmentally acceptable and provide a better "shine" on cleaned hard surfaces.

When intended for use in the neat form, the liquid compositions can be packaged under pressure in an aerosol container or in a pump-type sprayer for the so-called spray-and-wipe type of application.

15 Because the compositions as prepared are aqueous liquid formulations and since no particular mixing is required to form the all purpose cleaning or microemulsion composition, the compositions are easily prepared simply by combining all the ingredients in a suitable vessel or container. The order of mixing the ingredients is not particularly important and generally the various ingredients can be added sequentially
20 or all at once or in the form of aqueous solutions of each or all of the primary detergents and cosurfactants can be separately prepared and combined with each other and with the perfume. The magnesium salt, or other multivalent metal compound, when present, can be added as an aqueous solution thereof or can be added directly. It is not necessary to use elevated temperatures in the formation step
25 and room temperature is sufficient.

The instant all purpose cleaning microemulsion compositions explicitly exclude alkali metal silicates and alkali metal builders such as alkali metal polyphosphates, alkali metal carbonates, alkali metal phosphonates and alkali metal citrates because

these materials, if used in the instant composition, would cause the composition to have a high pH as well as leaving residue on the surface being cleaned.

The following examples illustrate liquid cleaning compositions of the described invention. Unless otherwise specified, all percentages are by weight. The exemplified compositions are illustrative only and do not limit the scope of the invention. Unless otherwise specified, the proportions in the examples and elsewhere in the specification are by weight.

Example 1

The following compositions in wt. % were prepared:

10

	A	B	C	D	E
Sodium C9-C13 linear alkylbenzene sulfonate (LAS) (52%)	4.67	4.67	4.67	4.67	4.67
Cocoamidopropyl betaine (30%)	0.83	0.83	0.83	0.83	0.83
Isohexyl neopentanoate	--	0.75	--	0.75	--
PEG-12 distearate	--	--	0.75	--	0.75
Diethyleneglycol mono n-butyl ether	3.0	3.0	3.0	4.6	4.6
C12-14 fatty acid	0.25	0.25	0.25	0.25	0.25
Perfume	--	--	--	0.7	0.7
Water	Bal.	Bal.	Bal.	Bal.	Bal.

Foam tests were performed on Samples A-E

Foam tests ^a	A	B	C	D	E
Initial Height (mm)	48	50	53	50.5	34
Final Height (mm) ^b	30	10.5	17.5	0	28
Maximum decrease ^c (mm/sec)	0.15	0.32	0.33	1.22	0.10
Time at max. decrease ^d (sec)	45	45	45	45	15

(a) One liter of tap water at room temperature (20-22C) having a water hardness of 300 ppm (expressed as CaCO₃ ppm) is poured under pressure onto 15 grs of composition in a three liter beaker. The water is poured at a pressure of 0.3 kg/cm², through a nozzle having a diameter of 0.5 cm, and at a distance of about 35 cm from nozzle to beaker bottom. The generated initial foam height is measured directly after dispensing one liter water. The foam height is again measured after 30 seconds, 60 seconds, 150 seconds, and 300 seconds.

(b) Final height is defined as the foam height remaining after 300 seconds.

(c) Maximum decrease is defined as the highest rate of foam collapse achieved within time period 0 to 300 seconds.

20

(d) Time at which the composition exhibits the highest rate of foam collapse during foam profile evolution.

What Is Claimed:

1. A cleaning composition comprising:
 - (a) about 0.5 wt. % to about 20 wt. % of anionic surfactant;
 - (b) about 0.5 wt. % to about 5 wt. % of a zwitterionic surfactant;
 - 5 (c) 0.25% to 4% of a foam control agent; and
 - (d) the balance being water.
2. The cleaning composition of Claim 1 which further contains a multivalent salt of a multivalent metal cation.
3. The cleaning composition of Claim 2 wherein the multivalent metal cation
10 is magnesium or aluminum.
4. The cleaning composition of Claim 2, wherein said composition contains 0.9 to 1.4 equivalents of said cation per equivalent of anionic surfactant.
5. The cleaning composition of Claim 3 wherein said multivalent salt is magnesium oxide or magnesium sulfate.
- 15 6. The composition of Claim 1 wherein said foam control agent is selected from the group consisting of organic monoesters, organic diesters and C₈-C₁₂ organic diols and mixtures thereof.