

(No Model.)

E. L. MANSFIELD.

REAMING TOOL.

No. 352,829.

Patented Nov. 16, 1886.

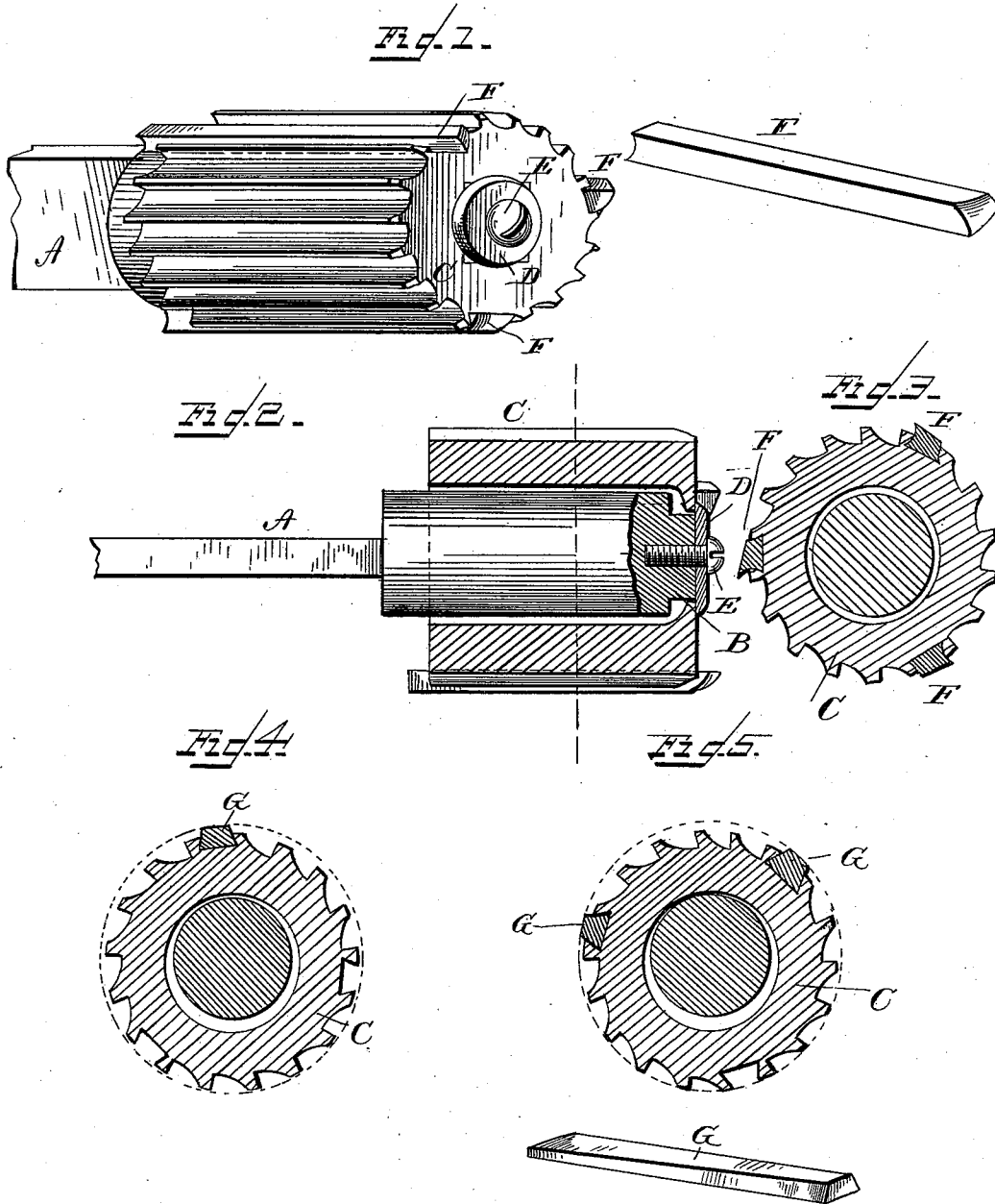

WITNESSES
F. L. Curran
Edward Stanton

Edwin L. Mansfield,
INVENTOR,
By Louis Bagger & Co.,
Attorney S.

UNITED STATES PATENT OFFICE.

EDWIN LASELLE MANSFIELD, OF BOSTON, MASSACHUSETTS.

REAMING-TOOL.

SPECIFICATION forming part of Letters Patent No. 352,829, dated November 16, 1886.

Application filed September 15, 1886. Serial No. 213,616. (No model.)

To all whom it may concern:

Be it known that I, EDWIN LASELLE MANSFIELD, of Boston, in the county of Suffolk and State of Massachusetts, have invented certain
5 new and useful Improvements in Reaming-Tools; and I do hereby declare that the following is a full, clear, and exact description of the invention, which will enable others skilled in the art to which it appertains to
10 make and use the same, reference being had to the accompanying drawings, which form a part of this specification, and in which—

Figure 1 is a perspective view of my improved reamer. Fig. 2 is a longitudinal axial
15 section of the same. Fig. 3 is a transverse section on line *x x* of Fig. 2. Fig. 4 is a similar section of the reamer adapted to form a tapering surface, and Fig. 5 is a like view of the same adapted to form a surface of greater
20 taper.

Like letters of reference indicate corresponding parts throughout the several figures.

My invention has relation to reaming-tools; and it consists in the improved construction
25 and combination of parts constituting the same, as will be hereinafter fully set forth.

The object of my invention is to so construct a reamer that it shall produce as accurate work when used in a lathe as when operated
30 by hand, the construction being such that the cutting portion shall be sufficiently self-adjustable upon the shank to which it is attached as to adapt itself to follow the center grade. I accomplish this object by providing
35 the shank A with a cylindrical portion, which terminates in a rectangular portion, B. Upon the cylindrical portion is placed a hollow cylindrical cutter-head, C, fluted after the manner of ordinary fluted reamers, said head being provided at one end with a rectangular
40 opening corresponding to and fitting upon the portion B of the shank, to which it is secured by a washer, D, held in place by a screw, E, turned into the end of the shank. Three or
45 more of the flutes of said head are converted into dovetailed grooves, and into these grooves are placed the cutters F, for cylindrical reaming, or the keys G, for taper reaming, said keys being thinner at their forward than at
50 their rear ends.

The diameter of the inner cylindrical sur-

face of the head is greater than that of the cylindrical portion of the shank, thus permitting the axis of the head to vary from that of the shank and to follow the center of rotation
55 when the axis of the shank does not.

For reaming cylindrical surfaces the reamer may be used with or without the cutters. In using the reamer for tapering surfaces the cutters are removed from their grooves and one
60 or more of the keys inserted, in which condition the cutting is done by the side of the fluted head which is opposite to the keys. In Fig. 4 the relative position of the surface cut (shown by the dotted line) and the parts of
65 the reamer are represented, only one key being used. In Fig. 5 the same is illustrated with two keys in use, in which case the taper formed is of greater degree than that formed when one key is employed.
70

The edges of the cutters, keys, and grooves converge slightly from the front end toward the back end of the head, so that by striking on the flat end of the cutters and the large
75 ends of the wedges they may be unseated. One edge of a cutter is beveled and the other concave, which adapts it to fit the dovetailed grooves and to prominently present its cutting-edge, while both edges of the wedges are beveled simply to fit the grooves. The ends
80 of the cutters are sharpened in the usual manner, and form, with the concave edges, effective cutting-surfaces.

Having thus fully described my invention, I claim—

1. A reamer consisting of a fluted head adjustably connected to its shank. 85

2. A reamer consisting in the combination of a hollow cylindrical cutting-head and a shank formed with a cylindrical portion at
90 one end of less diameter than that of the inner cylindrical surface of said head.

3. The combination of a reamer-head provided with longitudinal dovetailed grooves and cutters removably secured in said grooves. 95

4. The combination of a fluted reamer-head, adjustably secured upon its shank and provided with longitudinal dovetailed grooves, and keys adapted to be removably secured in said grooves. 100

5. A reamer consisting in the combination of a hollow cylindrical fluted head provided

with a rectangular opening in one end, a shank
provided with a cylindrical portion at one end
which terminates in a rectangular portion, a
washer, and a screw for securing the head to
5 the shank, the diameter of the inner cylindrical
surface of the head being greater than that
of the cylindrical portion of the shank.

In testimony that I claim the foregoing as
my own I have hereunto affixed my signature
in presence of two witnesses.

EDWIN LASELLE MANSFIELD.

Witnesses:

EVERETT KENT DEXTER,

JOHN WENTWORTH PORTER.