

Nov. 15, 1955

O. BERNI

2,723,716

DOUBLE SLIDING LOUVRE BOARD VENETIAN BLIND, DESIGNED
TO DECREASE THE PENETRATION OF LIGHT WHEN CLOSED

Filed Feb. 10, 1954

2 Sheets-Sheet 1

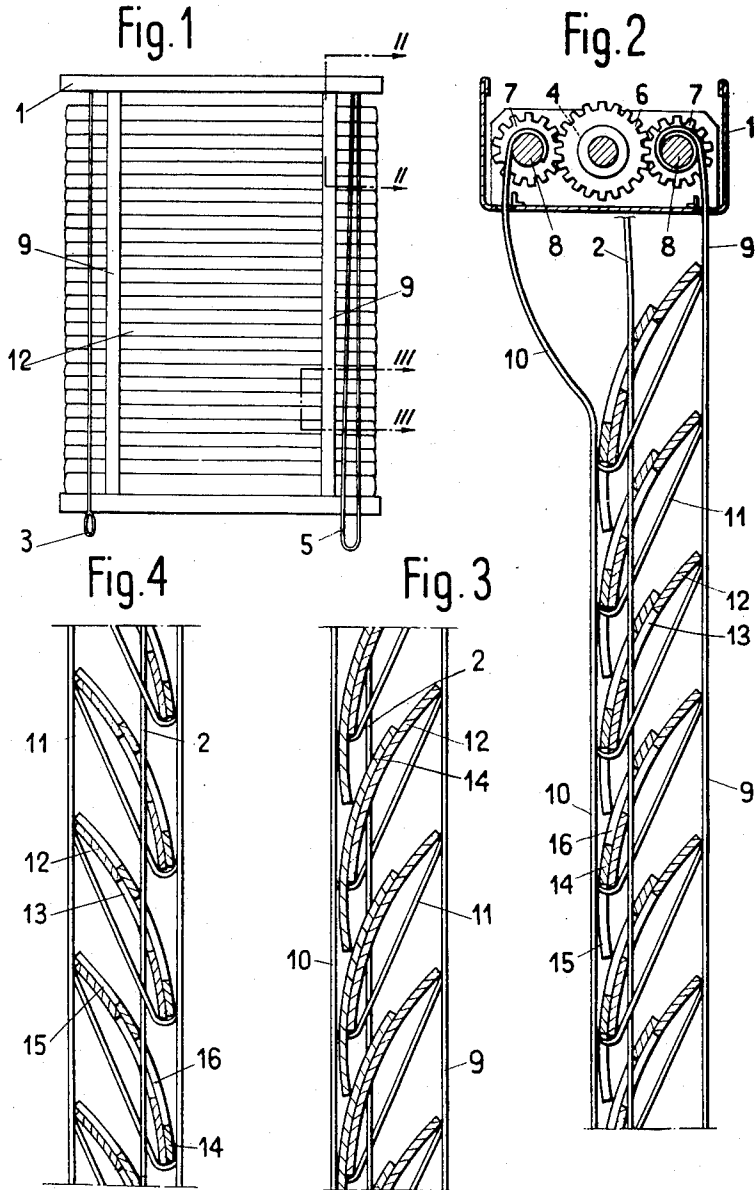

Inventor:
ORESTE BERNI

By
Richardson, David and Gordon
Attorneys

Nov. 15, 1955

O. BERNI

2,723,716

DOUBLE SLIDING LOUVRE BOARD VENETIAN BLIND, DESIGNED
TO DECREASE THE PENETRATION OF LIGHT WHEN CLOSED

Filed Feb. 10, 1954

2 Sheets-Sheet 2

Fig. 5

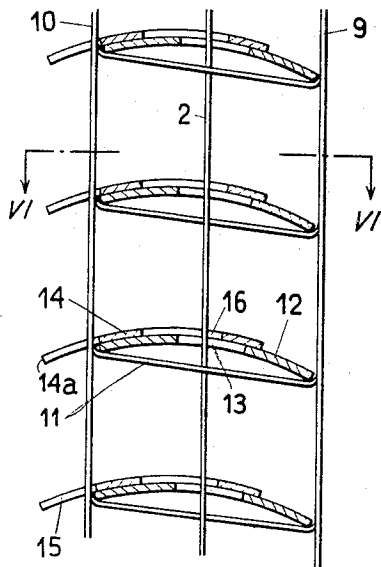

Fig. 6

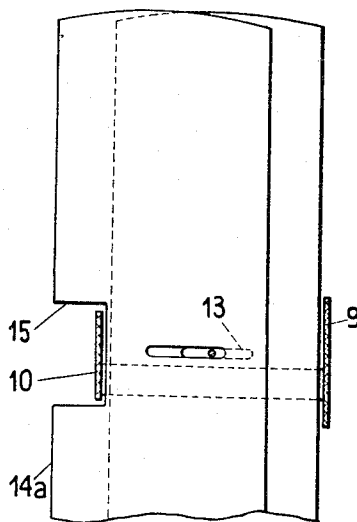
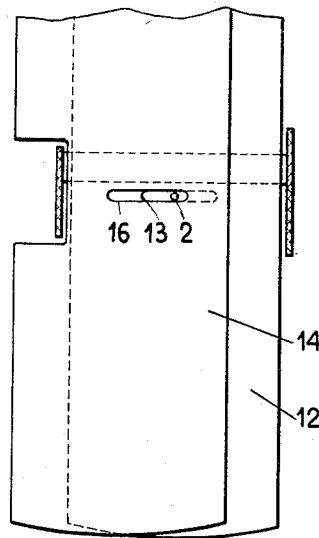
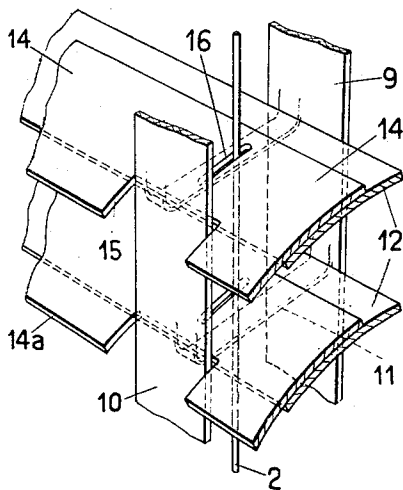

Fig. 7



Inventor:
ORESTE BERNI

By
Richardson, David and Nardoni
Attorneys.

1

2,723,716

DOUBLE SLIDING LOUVRE BOARD VENETIAN BLIND, DESIGNED TO DECREASE THE PENETRATION OF LIGHT WHEN CLOSED

Oreste Berni, Florence, Italy

Application February 10, 1954, Serial No. 409,462

Claims priority, application Italy February 14, 1953

5 Claims. (Cl. 160—168)

This invention relates to Venetian blinds comprising duplex relatively-slidable louvre slats.

It is known that in recesses, such as windows and the like, adjustable closures, called "Venetian blinds," are often used; the said blinds being formed by a plurality of arcuate louvre slats, assembled at least on two pairs of bearing strips, provided with connecting members, on which the slats bear, means being provided for pulling on one or on the other strip of one pair in order to orient the louvre slats in at least two positions, to which the partial penetration of the light or a closure respectively correspond, the closure acting to prevent the passage of light. Such Venetian blinds have the disadvantage that the louvre slats, when in the closure position, never contact with one another, and thus also in the position of maximum inclination of the louvre slats, a certain amount of light will pass through the blind. The disadvantage is due to the fact that owing to manufacturing limitations, the double strips are provided with connecting members which are located at a determined distance in relation to their length, which corresponds to the width of the louvre slats forming the blind. The slats are slightly arcuate in order to preserve a sufficient rigidity and allow the relative approach of the edges of each louvre slat to the convex surface of the underlying slat.

A Venetian blind according to the present invention has the object of avoiding the disadvantages of the penetration of light in the maximum inclination position of the louvre slats and brings about complete closure without modifying the proportions among the width of the louvre slats, the length of the connecting members between the strips of each pair of strips and the distance between the connecting members.

A Venetian blind constructed according to the present invention instead of a single louvre slat includes a pair of appropriately shaped louvre slats, each sliding in a direction perpendicular to its length, the camber of the section of the louvre slats parallel to the direction of sliding being capable of permitting the sliding movement. The louvre slats preferably have arc shaped sections. At least one of the louvre slats of each pair is provided with notches or the like along at least one of its edges and corresponding to the said strips, so as, following a certain inclination of the slats to allow the slat provided with notches to slide on the other slat owing to its inherent weight, and thus project with respect to the strips in order to cause its own free edge to approach and almost touch the upper louvre slat of the underlying pair of slats for the interception of the light.

The width of the two louvre slats of each pair may be equal to the length of the connecting members which secure the two strips of each pair of strips. The notches may be provided in a pair of cooperating slats either along the edges of one of the slats, or in the two edges of the same slat, the other slat being as wide as the length of the connecting members. Alternatively, one of the louvre slats may be provided with notches along one edge and the other slat may be provided with notches along the

2

opposite edge, in such a way that one slat may project on one side when the slats are inclined in one direction, and the other slat may project on the opposite side when the slats are inclined in the reverse direction. Rectangular notches are preferably provided and their width is at least equal to or greater than the width of the said strip which the notches embrace.

The depth of the notches, which latter are preferably rectangular, is determined on the basis of the projection of the edge of the slat which is required with respect to the strip, in order to obtain the approach or the resting of the said edge on the top slat of the underlying pair of slats.

The invention will be better understood with the aid of the accompanying drawings, which illustrate one constructional embodiment of the invention by way of example.

In the drawings:

Fig. 1 shows, on a reduced scale, a Venetian blind in side elevation and in the closed position;

Figs. 2 and 3 are respectively sections on a larger scale, on the lines II—II and III—III in Fig. 1;

Figs. 4 and 5 are fragmentary cross-sections, of a portion of the blind shown in Fig. 1, with the louvre slats in the upwardly and outwardly inclined position, and in a substantially horizontal position respectively;

Fig. 6 is a section on the line VI—VI in Fig. 4; and

Fig. 7 is a perspective view of an offset arrangement of the louvre slats in a substantially horizontal position.

Referring to the drawings:

The blind comprises an upper box 1 containing the usual control members, which include driving rollers for pullers or cords 2, which are reunited in a string 3 for raising and lowering the blind, in known manner. A drum 4 is turnably arranged in the box and can be turned in both directions by a small cord 5 which is wound on the drum, the latter being designed to drive, through a gear 6 and two symmetrical gears 7, two small shafts 8 which are longitudinally arranged in the box 1, and are designed to receive strips 9 and 10 respectively of each of the two pairs of strips forming the device for orientation of the louvre slats. In the construction now being described there are two pairs of strips, controlled by the small shafts 8 and by turning the drum 4 in the two directions, one of the strips 9 or 10 is drawn up while the other is released, this arrangement being known. The strips 9 and 10 of each pair of strips are connected by appropriate members 11, which are woven with or are sewn to the strips and are alternatively arranged on two alignments. Known louvre slats 12 of sector arcuate transverse sections, rest on the connecting members 11, in such a way that by pulling one of the strips and releasing the other (through the agency of the string 5), the louvre slats may be oriented outwardly and downwardly into the maximum inclination position (Figs. 1, 2 and 3) or in the substantially horizontal position (Figs. 5, 6 and 7) or in the inclined position opposite to that shown in Figs. 2 and 3, that is, towards the outside and the top (Fig. 4).

The pullers 2 for raising the blind are located between the pairs of strips 9 and 10 and pass through slots or holes 13 formed in the louvre slats. The pullers 2 and thus the slots 13 may also be offset with respect to the pairs of strips.

A second louvre slat 14 is superimposed on each louvre slat 12 and the former has the same width and camber as those of the slat 12 and may therefore slide on that slat perpendicularly to its length; along one edge and preferably its outer edge 14a, the slat 14 is provided corresponding to the strips 10, with rectangular notches 15, the width of each of which is at least equal to the width of the strip 10. Each louvre slat 14 is also pro-

3

vided with slots 16 for the puller 2 of a length greater than that of the slots 13.

By releasing the strip 10 and by pulling the strip 9, the louvre slats 12 are inclined as shown in Fig. 3 and the louvre slats 14 slide on the slats 12 with their edges 14a moving downwardly, the sliding movement being permitted by the notches 15, the depth of which corresponds to the maximum offset attainable between the louvre slats 12 and 14. In this way, the edge 14a of a louvre slat 14 approaches and also contacts the slat 14 of the underlying pair of slats. The light is efficiently intercepted in this way.

By pulling the strip 10 and releasing the strip 9, the louvre slats may be arranged as shown in Fig. 5 and by an additional release of the strip 9 and an additional pull on the strip 10, it is possible to obtain the position shown in Fig. 4, wherein the louvre slats 12, 14 are exactly super-imposed. When returning to the position of Fig. 5, from the position of Fig. 4, the louvre slats are horizontal but superimposed, instead of being offset as shown in Fig. 5.

As above mentioned, it is possible to use pairs of strips 9-10 which are unchanged with respect to those at present used in the sizing of the connecting members 11.

The louvre slats 12 and 14 in practice are thinner than shown in the drawing, wherein the thickness has been increased for clarity.

The strips of each pair of strips, such as 9 and 10, may be different widths. For instance, the inner strips 9 may be wider than the outer strips 10, as shown in Fig. 6. By this arrangement, or by any other arrangement adopted, the wider strip is capable of intercepting the light which eventually filters through at the narrower strip owing to the presence of the notches 15, since the edges 14a are interrupted at the said notches.

The drawing only illustrates one constructional form of the invention, which may be varied in shape and arrangements. For example, the louvre slats 14 could be of any suitable shape and could be wider or narrower than the slats 12 and provided with notches 15 on the opposite longitudinal edges, being able in this case to slide with respect to the louvre slat 12 and also to project towards the inside in the position shown in Fig. 4. The louvre slats 12 may be provided with notches similar to the notches 15 on the edge opposite to the edge 14a. In this case, while the louvre slats 14 in the position shown in Fig. 4 are stopped by the connecting members 11, the louvre slats 12 could slide so as to project from the slats 14. The louvre slats 14 could be arranged under the slats 12 instead of being located above them.

What I claim is:

1. A full-closure Venetian blind comprising a plurality of horizontally extending, vertically spaced slats, at least two pairs of tapes, the tapes of each pair being arranged on the opposite sides of said slats, a plurality of cross-bars connecting said vertically spaced tapes and lift means for the tapes, a second slat resting on each of said slats so as to be transversely slidable thereon and forming with the underlying slat a pair of slats, one of the slats of each pair having a rectangular notch formed in correspondence with the tapes in the longitudinal edge thereof which is downwardly located when the blind is tilted in the closed position and longitudinally extending for a distance equal to the width of said tapes.

4

2. A full-closure Venetian blind comprising a plurality of horizontally extending, vertically spaced slats, at least two pairs of tapes, the tapes of each pair being arranged on the opposite sides of said slats, a plurality of cross-bars connecting said vertically spaced tapes and being staggered on opposite sides of the centerline of the tapes, and lift means for the slats, a second slat rested on each of said slats so as to be transversely slidable thereon, each of said second slats having rectangular notches formed in correspondence with the tapes in the longitudinal edge thereof which is downwardly located when the blind is tilted in the closure position and longitudinally extending for a distance equal to the width of said tapes.

3. A full-closure Venetian blind comprising a plurality of horizontally extending, vertically spaced slats, at least two pairs of tapes, the tapes of each pair being arranged on the opposite sides of said slats and a plurality of vertically spaced narrow cross-bars staggered on opposite sides of the centerline of the tapes, and connecting the tapes together, lift cords extending through the tapes of each pair and through said staggered cross-bars, each of said slats being crowned and having transversely elongated cord holes provided therein in the longitudinal centerline of the slat, said lift cords passing through said cord holes, each of said slats having a width equal to the width of said cross-bars, a second slat resting on each of said slats and being slidable in a direction perpendicular to the longitudinal edges of said slat, each of said second slats having cord holes which correspond respectively to the cord holes of the slats upon which it is resting and which are substantially transversely more elongated than said holes, each of said lift cords also passing through said cord holes, said second slat having longitudinally elongated notches formed in its longitudinal edge which is downwardly located when the blind is tilted in the closure position and in correspondence with each of the tapes adjacent said edge, said notches having a width equal to the width of said tapes adjacent said edge and each of said tapes adjacent said edge being narrower than the other tape of each pair.

4. A Venetian blind according to claim 3, wherein said second slats are similar to the slats whereupon they rest.

5. A full-closure Venetian blind comprising a plurality of horizontally extending, vertically spaced slats, at least two pairs of tapes, the tapes of each pair being arranged on the opposite sides of said slats and a plurality of vertically spaced narrow cross-bars connecting said tapes together, lift means for the slats, each of said slats having a width equal to the width of said cross bars, a second slat resting on each of said slats and being slidable in a direction perpendicular to the longitudinal edges of said slat, said second slat having longitudinally elongated notches formed in its longitudinal edge which is downwardly located when the blind is tilted in the closure position and in correspondence with each of the tapes adjacent said edge, said notches having a width equal to the width of said tapes adjacent said edge and each of said tapes adjacent said edge being narrower than the other tape of each pair.

References Cited in the file of this patent

UNITED STATES PATENTS

1,957,272	Kuyper	May 1, 1934
2,646,115	Bucher et al.	July 21, 1953