

(19) World Intellectual Property Organization
International Bureau



(43) International Publication Date
30 November 2006 (30.11.2006)

PCT

(10) International Publication Number
WO 2006/126880 A2

(51) International Patent Classification: Not classified

(21) International Application Number:
PCT/NL2006/050120

(22) International Filing Date: 19 May 2006 (19.05.2006)

(25) Filing Language: Dutch

(26) Publication Language: English

(30) Priority Data:
1029129 25 May 2005 (25.05.2005) NL

(71) Applicant (for all designated States except US): **TECH-
NISCHE UNIVERSITEIT DELFT** [NL/NL]; Ju-
lianalaan 134, NL-2628 BL Delft (NL).

(72) Inventor; and

(75) Inventor/Applicant (for US only): **KRUIT, Pieter**
[NL/NL]; Koornmarkt 49, NL-2611 EB Delft (NL).

(74) Agent: **VAN BREDA, Jacques**; 20052, Weteringschans
96, 1017 Xs Amsterdam, Netherlands, NL-1000 HB Ams-
terdam (NL).

(81) Designated States (unless otherwise indicated, for every kind of national protection available): AE, AG, AL, AM, AT, AU, AZ, BA, BB, BG, BR, BW, BY, BZ, CA, CH, CN, CO, CR, CU, CZ, DE, DK, DM, DZ, EC, EE, EG, ES, FI, GB, GD, GE, GH, GM, HR, HU, ID, IL, IN, IS, JP, KE, KG, KM, KN, KP, KR, KZ, LC, LK, LR, LS, LT, LU, LV, LY, MA, MD, MG, MK, MN, MW, MX, MZ, NA, NG, NI, NO, NZ, OM, PG, PH, PL, PT, RO, RU, SC, SD, SE, SG, SK, SL, SM, SY, TJ, TM, TN, TR, TT, TZ, UA, UG, US, UZ, VC, VN, YU, ZA, ZM, ZW.

(84) Designated States (unless otherwise indicated, for every kind of regional protection available): ARIPO (BW, GH, GM, KE, LS, MW, MZ, NA, SD, SL, SZ, TZ, UG, ZM, ZW), Eurasian (AM, AZ, BY, KG, KZ, MD, RU, TJ, TM), European (AT, BE, BG, CH, CY, CZ, DE, DK, EE, ES, FI, FR, GB, GR, HU, IE, IS, IT, LT, LU, LV, MC, NL, PL, PT, RO, SE, SI, SK, TR), OAPI (BF, BJ, CF, CG, CI, CM, GA, GN, GQ, GW, ML, MR, NE, SN, TD, TG).

Published:

— without international search report and to be republished upon receipt of that report

For two-letter codes and other abbreviations, refer to the "Guidance Notes on Codes and Abbreviations" appearing at the beginning of each regular issue of the PCT Gazette.



WO 2006/126880 A2

(54) Title: SCANNING TRANSMISSION ELECTRON MICROSCOPE

(57) Abstract: The invention relates to a scanning transmission electron microscope comprising an electron source, an electron accelerator and deflection means for directing electrons emitted by the electron source at an object to be examined, and in addition a detector for detecting electrons coming from the object and, connected to the detector, a device for processing the detected electrons so as to form an object image, wherein a beam splitter is provided for dividing the electron beam from the electron source into beamlets to be directed at the object to be examined, and wherein the detector is designed for the detection of separate electron patterns that correspond to said beamlets.

Scanning transmission electron microscope

The invention relates to a scanning transmission electron microscope comprising an electron source, an electron accelerator and deflection means for directing electrons emitted by the electron source at an object to be examined, and in addition a detector for detecting electrons coming from the object and, connected to the detector, a device for processing the detected electrons so as to form an object image.

Such an electron microscope is known from practice.

10 A drawback of the known electron microscope is that imaging takes much time. This is even exacerbated with so-called electron energy loss spectroscopy, wherein an energy spectrum of the various pixels has to be included for the formation of the intended object image. In order to alleviate this problem, a number of filtered images are sometimes used that have been obtained by means of transmission electron microscopy, and wherein for each image an individual energy loss is applied. The disadvantage of this is that a considerable amount of radiation damage may occur.

20 An object of the invention is to provide an electron microscope that facilitates faster imaging, or with which it is possible to determine more quickly the different materials of which an object to be examined is composed.

The electron microscope according to the invention is therefore characterized by one or several of the appended claims.

30 In a first aspect of the invention, the electron microscope is characterized in that a beam splitter is provided for dividing the electron beam from the electron source into beamlets to be directed at the object to be examined, and in that the detector is designed for the detection of separate electron patterns that correspond to said beamlets.

This affords the advantage that the object can be illuminated by a plurality of focussed beams simultaneously, so that the multiple beams can simultaneously produce an

equal number of images of the object. Thus the time that can be gained is proportional to the number of beamlets applied.

The electron microscope according to the invention is suitably embodied such that during operation an adjustable
5 diaphragm plate is provided between the object to be examined and the detector.

This facilitates the formation of so-called bright-field and dark-field images.

In yet another aspect of the invention, the electron
10 microscope is preferably characterized in that during operation an organ with dispersive properties is placed between the object to be examined and the detector.

Using the electron microscope according to the invention, it is thus possible to simply and quickly determine
15 a plurality of spectra of the object to be examined.

Hereinafter the invention will be further elucidated by way of a number of non-limiting exemplary embodiments and with reference to the drawing.

The drawing shows:

- 20
- in Figure 1, a first embodiment of an electron microscope according to the invention and
 - in Figure 2, a second embodiment of an electron microscope according to the invention.

Identical reference numerals in the figures refer to
25 similar components. Both Figure 1 and Figure 2 schematically illustrate the configuration of the electron microscope according to the invention.

The electron microscope comprises first an electron source 1 and, viewed in the direction of the object 2 to be
30 examined, successively a beam splitter 3, an electron accelerator 4 which may be equipped with lenses, and deflection means 5 for directing the electron beamlets from the electron source 1 and beam splitter 3 at the object to be examined 2.

Following said object 2, viewed in the direction of
35 observation, there is preferably provided an objective lens 6 and a detector 7 for the detection of electrons coming from the object 2.

In a manner well known to those skilled in the art,

a processing device, for example a computer system, is connected to the detector 7 with which the electrons detected by the detector 7 can be visualised in the form of an object image to be displayed on a monitor.

5 In accordance with the invention, the just referred to detector 7 is embodied as a multispot detector, i.e. it is designed for detecting separate electron spots corresponding to the above-mentioned beamlets of the electron beams, and representing the illumination of the object 2 to be examined.

10 Figure 1 shows the embodiment in which an adjustable diaphragm plate 8 is placed between the object 2 to be examined and the detector 7, making the apparatus suitable for dark-field imaging or bright-field imaging. How this works in practice is well known to those skilled in the art so that a
15 further explanation is superfluous.

Following the diaphragm plate 8 deflection means and a lens system 9 may be provided for the controlled illumination of the multipixel detector 7.

Figure 2 shows that following the objective lens 6
20 and the deflection means and lens system 9, an organ 10 having dispersive properties may be placed for the differentiation in the spectral lines, which are indicative for the materials of which the object 2 to be examined is composed.

The dispersive organ 10 may be followed in the usual
25 manner by a lens system 11.

CLAIMS

1. A scanning transmission electron microscope comprising an electron source (1), an electron accelerator (4) and deflection means (5) for directing electrons emitted by the electron source (1) at an object (2) to be examined, and
5 in addition a detector (7) for detecting electrons coming from the object (2) and, connected to the detector (7), a device for processing the detected electrons so as to form an object image, **characterised** in that a beam splitter (3) is provided for dividing the electron beam from the electron
10 source (1) into beamlets to be directed at the object (2) to be examined, and in that the detector (7) is designed for the detection of separate electron patterns that correspond to said beamlets.

2. An electron microscope according to claim 1,
15 **characterised** in that that during operation an adjustable diaphragm plate (8) is provided between the object (2) to be examined and the detector (7).

3. An electron microscope according to claim 1 or 2,
20 **characterised** in that during operation an organ (10) with dispersive properties is placed between the object (2) to be examined and the detector (7).

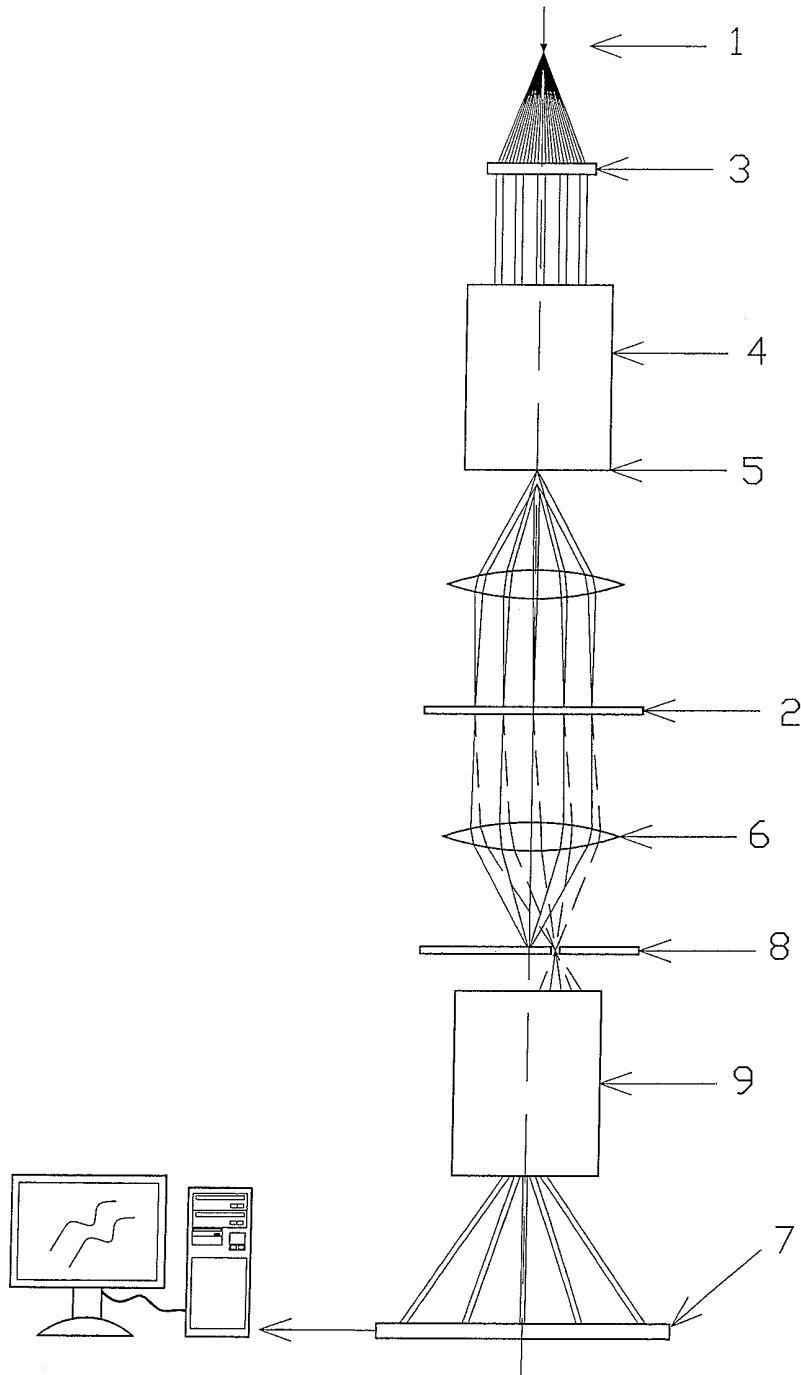

FIG. 1

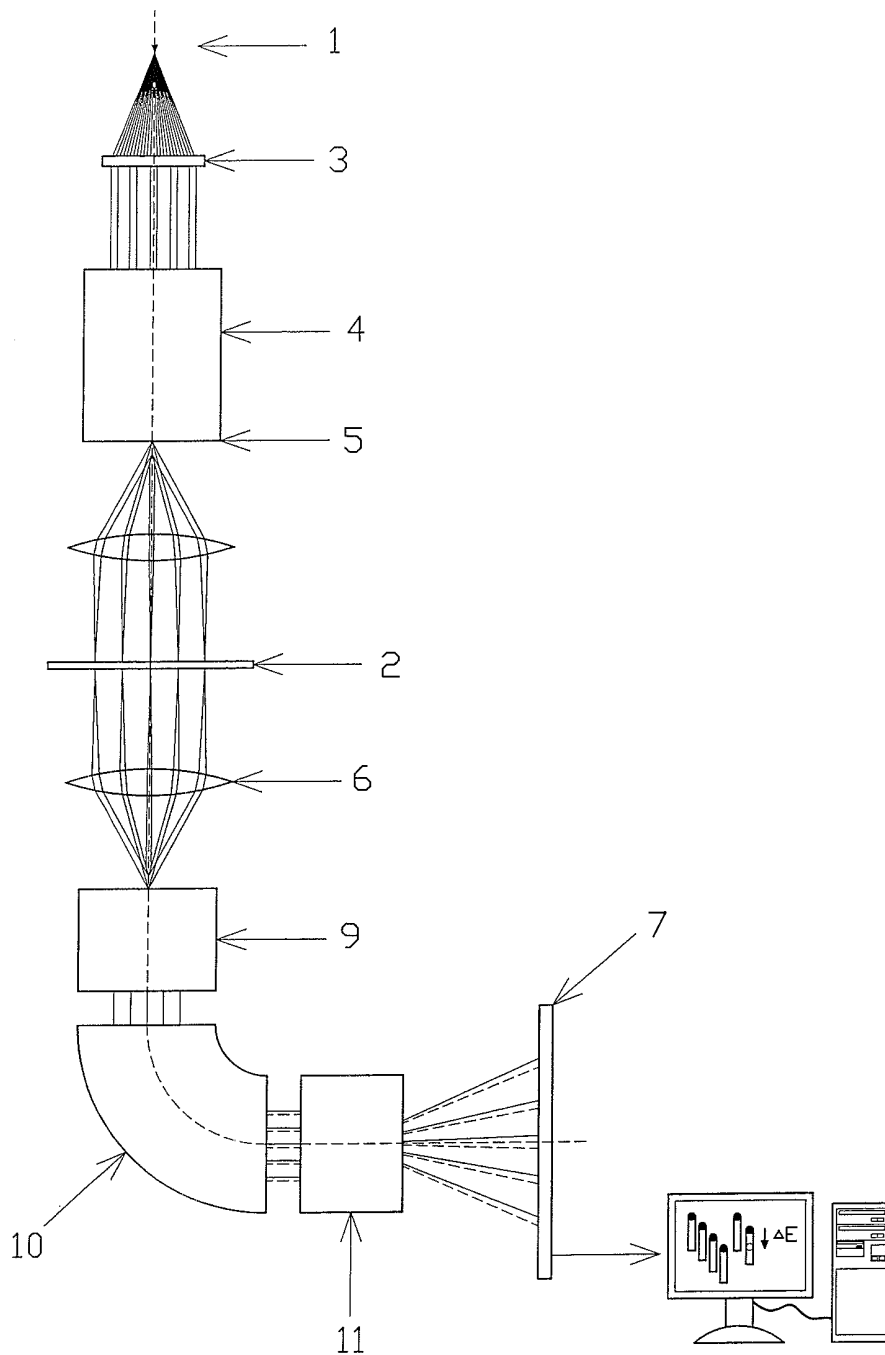

FIG. 2