

(12) PATENT
(19) AUSTRALIAN PATENT OFFICE

(11) Application No. AU 199855035 B2
(10) Patent No. 731098

(54) Title
A mobile communication unit and a radio transmitter for communicating with such mobile communication unit

(51)⁶ International Patent Classification(s)
H04B 007/005 H04M 001/72
H01Q 001/24

(21) Application No: 199855035 (22) Application Date: 1997.12.17

(87) WIPO No: WO98/28860

(30) Priority Data

(31) Number	(32) Date	(33) Country
9604739	1996.12.20	SE

(43) Publication Date : 1998.07.17
(43) Publication Journal Date : 1998.09.10
(44) Accepted Journal Date : 2001.03.22

(71) Applicant(s)
Telefonaktiebolaget LM Ericsson

(72) Inventor(s)
B. Johanna Isberg; Mikael Dahlkvist; L. Fredrik Liljegren; Ulf C. Bjorkengren; Anders Khullar

(74) Agent/Attorney
WATERMARK PATENT and TRADEMARK ATTORNEYS, Locked Bag 5, HAWTHORN VIC 3122

(56) Related Art
US 5541609
GB 2282705
WO 95/34178

OPI DATE 17/07/98 APPLN. ID 55035/98
AOJP DATE 10/09/98 PCT NUMBER PCT/SE97/02135



AU9855035

CT)

(51) International Patent Classification ⁶ : H04B 7/005, H04M 1/72, H01Q 1/24		A1	(11) International Publication Number: WO 98/28860
			(43) International Publication Date: 2 July 1998 (02.07.98)
(21) International Application Number: PCT/SE97/02135		(81) Designated States: AL, AM, AT, AU, AZ, BA, BB, BG, BR, BY, CA, CH, CN, CU, CZ, DE, DK, EE, ES, FI, GB, GE, GH, GM, HU, ID, IL, IS, JP, KE, KG, KP, KR, KZ, LC, LK, LR, LS, LT, LU, LV, MD, MG, MK, MN, MW, MX, NO, NZ, PL, PT, RO, RU, SD, SE, SG, SI, SK, SL, TJ, TM, TR, TT, UA, UG, UZ, VN, YU, ZW, ARIPO patent (GH, GM, KE, LS, MW, SD, SZ, UG, ZW), European patent (AM, AZ, BY, KG, KZ, MD, RU, TJ, TM), Eurasian patent (AT, BE, CH, DE, DK, ES, FI, FR, GB, GR, IE, IT, LU, MC, NL, PT, SE), OAPI patent (BF, BJ, CF, CG, CI, CM, GA, GN, ML, MR, NE, SN, TD, TG).	
(22) International Filing Date: 17 December 1997 (17.12.97)		Published <i>With international search report. Before the expiration of the time limit for amending the claims and to be republished in the event of the receipt of amendments.</i>	
(30) Priority Data: 9604739-4 20 December 1996 (20.12.96) SE			
(71) Applicant: TELEFONAKTIEBOLAGET LM ERICSSON (publ) [SE/SE]; S-126 25 Stockholm (SE).			
(72) Inventors: ISBERG, B., Johanna; Viborgsslingan 42, S-224 72 Lund (SE). DAHLKVIST, Mikael; Näktergalsvägen 5, S-247 36 Södra Sandby (SE). LILJEGREN, L., Fredrik; Högbovägen 1 K, S-227 10 Lund (SE). BJÖRKENGREN, Ulf, C.; Näktergalsvägen 26, S-237 34 Bjärred (SE). KHULLAR, Anders; Trastvägen 20, S-237 37 Brårred (SE).			
(74) Agents: HERBJØRNSSEN, Rut et al.; H. Albihs Patentbyrå AB, P.O. Box 3137, S-103 62 Stockholm (SE).			

(54) Title: A MOBILE COMMUNICATION UNIT AND A RADIO TRANSMITTER FOR COMMUNICATING WITH SUCH MOBILE COMMUNICATION UNIT

(57) Abstract

To enable use of an intelligent mobile communication unit (1) in areas where there are restrictions on the emission of radio frequency, the unit comprises a removable antenna (2), and a switch which is adapted to switch off the power to at least the radio frequency emitting part of the unit upon removal of the antenna, thereby actively preventing radio frequency radiation from the unit even if non-radio frequency energy emitting parts of the unit (1) are operable.

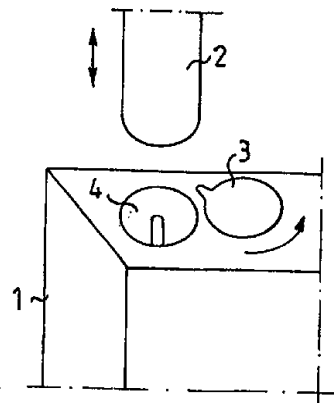

**A MOBILE COMMUNICATION UNIT AND A RADIO TRANSMITTER
FOR COMMUNICATING WITH SUCH MOBILE COMMUNICATION
UNIT**

5 **TECHNICAL FIELD**

The invention relates to mobile communication units as well as to radio transmitters for communicating with such mobile communication units.

BACKGROUND OF THE INVENTION

10 The radio parts of mobile communication units, e.g. mobile phones or more advanced, intelligent mobile phones also having a computer part of some kind, may interfere in a hazardous way with electronic equipment in e.g. airplanes, airport terminal buildings, hospitals and other buildings having a demand on high margins against radio frequency interference.

15

Today, it is up to the individual users of such mobile communication units to switch off the units upon entering such restricted areas.

20 By switching off the units, also the computer part, if any, will of course be switched off. However, it may be desirable to use the computer part of such units in such restricted areas without running the risk of disturbing sensitive electronic equipment even if the radio parts have been switched off.

BRIEF DESCRIPTION OF THE INVENTION

25 One object of the invention is to bring about a mobile communication unit in which e.g. the computer part, if any, can be used also in areas having restrictions on radio frequency emission.

30 This is attained by means of the mobile communication units according to the invention by providing them with means for actively preventing the radio frequency

emitting parts of the unit from causing disturbances at the same time as non-radio frequency emitting parts of the unit may be used by a user.

Another object is, on the one hand, to bring about mobile communication units in which at least the radio part is automatically switched off upon entering an area with restrictions on radio frequency emission, and, on the other hand, to bring about a radio transmitter cooperating with such mobile communication units to switch them off upon entering such restricted areas.

This is attained in accordance with the invention by providing the mobile communication units with a detector for detecting a power shut-down signal emitted by a radio transmitter in or near an area having restrictions on radio frequency emission. The power shut-down signal is emitted in order to turn off the power to at least the radio parts of mobile communication units entering the restricted area.

Hereby, it will be possible for a user to use other parts such as the computer part of such mobile communication units also in restricted areas without the risk of disturbing sensitive electronic equipment in such areas.

In one aspect, the present invention provides a mobile communication including

a removable antenna, and a switch which is adapted to switch off power to at least radio frequency emitting parts of the unit upon removal of the antenna or

a removable antenna, and a spring loaded lid which is adapted to automatically and shieldingly cover an opening left in the unit upon removal of the antenna or

a detector adapted to detect a power shut-down signal transmitted by a radio transmitter and, in response hereto, switch off power to at least radio frequency emitting parts of the unit or

a control means adapted to recognise a predetermined code keyed on the keypad of the unit and, in response hereto, to switch off power to at least radio frequency emitting parts of the unit.

In a further aspect, the present invention provides a radio transmitter to be located in or near an area where mobile communication units must not radiate



radio frequency energy, wherein the radio transmitter is adapted to transmit a power shut-down signal to be received by a detector in a mobile communication unit within said area, the detector being adapted, upon reception of the power shut-down signal, to generate a power-down signal to be supplied to a power source of the mobile communication unit to control the power source to switch off power to at least radio frequency emitting parts of the mobile communication units.

BRIEF DESCRIPTION OF THE DRAWING

The invention will be described more in detail below with reference to the appended drawing, on which

Figure 1 schematically illustrates a first embodiment of a mobile communication unit according to the invention, and

Figure 2 is a schematical block diagram of a second embodiment of a mobile communication unit according to the invention, cooperating with a radio transmitter according to the invention.

10
11
12
13
14
15
16
17
18
19
20
21
22
23
24
25
26
27
28
29
30
31
32
33
34
35
36
37
38
39
40
41
42
43
44
45
46
47
48
49
50
51
52
53
54
55
56
57
58
59
60
61
62
63
64
65
66
67
68
69
70
71
72
73
74
75
76
77
78
79
80
81
82
83
84
85
86
87
88
89
90
91
92
93
94
95
96
97
98
99
100



PREFERRED EMBODIMENTS

Fig. 1 schematically illustrates a first embodiment of the invention for actively preventing radio frequency radiation from a mobile communication unit, generally denoted 1. Besides a radio part (not shown), the unit 1 may comprise intelligent parts such as a computer part (not shown).

In accordance with this embodiment of the invention, the mobile communication unit 1 is provided with a removable antenna 2. Upon removal of the antenna 2 from the mobile communication unit 1, a spring loaded, electrically grounded lid 3 is automatically moved into position to cover an opening 4 left in top of the frame of the mobile communication unit 1 upon removal of the antenna 2.

The lid 3, together with shielding (not shown) in the frame of the mobile communication unit 1, is adapted to effectively shield all radio frequency emitting parts in the mobile communication unit 1. Thus, it will be possible to use other parts such as the computer part, if any, of the mobile communication unit 1 without running the risk of emitting disturbing radio frequency energy.

According to the invention, a switch (not shown) can be provided in the mobile communication unit 1 to disconnect the power to at least the radio frequency emitting parts in the mobile communication unit 1 upon removal of the antenna 2. Of course, that switch may be adapted to switch off the power in the whole unit 1.

Also according to the invention, this switch (not shown) can be combined with the lid 3 to further ensure that no disturbing radio frequency energy is emitted by the radio frequency emitting parts in the mobile communication unit 1 upon removal of the antenna 2.

Fig. 2 illustrates a second embodiment of the invention.

The embodiment shown in Fig. 2 comprises a radio transmitter 5 and a mobile communication unit 6. The radio transmitter 5 may be a normal base station. It may also be a separate radio transmitter specifically located in or near an area where mobile communication units, such as the unit 6 in Fig.2, must not radiate radio
5 frequency energy.

In accordance with this embodiment of the invention, the radio transmitter 5 is adapted to transmit a predetermined power shut-down signal for automatically switching off at least the radio frequency emitting part of any mobile communication
10 unit, such as unit 6, present within that area. This power shut-down signal may be generated constantly by the radio transmitter 5. As an alternative, it may instead be generated when the radio transmitter 5 detects that a mobile communication unit approaches or enters a restricted area.

15 To facilitate the switching off of at least the radio frequency emitting part of the mobile communication unit 6 approaching or entering the restricted area, the mobile communication unit 6 according to the invention comprises a detector 7. The detector 7 is connected to the antenna 8 of the mobile communication unit 6 and is adapted to detect the power shut-down signal transmitted by the radio transmitter 5.
20

Upon detection of the power shut-down signal, the detector 7 is adapted to generate a power-down signal. This signal is supplied to the power source (not shown) of the mobile communication unit 6. Upon reception of the power-down signal, the power source disconnects the power to at least all the radio frequency emitting parts (not
25 shown) of the mobile communication unit 6. Of course, the power can be switched off in the whole unit 6.

In order to protect the mobile communication unit 6 from being deactivated unintentionally, the power shut-down signal transmitted by the radio transmitter 5
30 may according to the invention include a coded message. In such cases, the mobile communication unit 6 comprises a decoder 9 which in the embodiment shown is

connected to the output terminal of the detector 7. This decoder 9 is adapted to decode the coded message transmitted by the radio transmitter 5. A power down signal PDWN will only be supplied to the power source of the unit 6 if a valid power shut-down message is received and decoded.

5

When the power shut-down signal transmitted by the radio transmitter 5 is no longer detected by the detector 7 in the mobile communication unit 6, e.g. due to the fact that the mobile communication unit 6 has been moved out of or away from the restricted area, the power will be switched on again in the mobile communication
10 unit 6. Its radio frequency emitting part (not shown) will return to its active state and the mobile communication unit 6 will be ready for normal operation.

In accordance with this embodiment of the invention, at least the radio frequency emitting parts of the mobile communication unit 6 are deactivated by the reception
15 of the power shut-down signal from the radio transmitter 5. Thus, the user of the mobile communication unit 6 will be able to use other parts such as e.g. a computer part, if any, of the mobile communication unit 6.

As indicated above, the power shut-down signal transmitted by the radio transmitter
20 5 and detected by the detector 7 may cause the power to be switched off in the whole mobile communication unit 6 and not just to the radio frequency emitting parts. A user wishing to use the non-radio frequency emitting parts of the unit 6 within the restricted area would, thus, have to turn on the unit 6. However, in that case, only the non-radio frequency emitting parts of the unit 6 would be turned on
25 while the radio frequency emitting parts would remain turned off. Also, upon leaving the restricted area, the user would have to turn on the unit 6 again.

In a third embodiment (not shown) of the invention, the mobile communication unit is provided with control means, adapted to recognize a predetermined code keyed by
30 the user on the keypad of the unit. In response to the detection of the code, the control means is adapted to switch off the power to at least the radio frequency

emitting part of the unit. If provided with e.g. a computer part, the mobile communication unit will, then, operate in an off-net mode in which it will still be possible to use the computer part. Also in this embodiment, the power may be switched off in the whole unit.

5

Thus, as should be apparent from the above, by means of the mobile communication unit according to the invention, the risk of unintentionally disturbing radio frequency sensitive electronic equipment, is considerably reduced.

THE CLAIMS DEFINING THE INVENTION ARE AS FOLLOWS:

1. A mobile communication unit including
 - a removable antenna, and a switch which is adapted to switch off power to at least radio frequency emitting parts of the unit upon removal of the antenna or
 - a removable antenna, and a spring loaded lid which is adapted to automatically and shieldingly cover an opening left in the unit upon removal of the antenna or
 - a detector adapted to detect a power shut-down signal transmitted by a radio transmitter and, in response hereto, switch off power to at least radio frequency emitting parts of the unit or
 - a control means adapted to recognise a predetermined code keyed on the keypad of the unit and, in response hereto, to switch off power to at least radio frequency emitting parts of the unit.
2. A mobile communication unit according to claim 1, wherein power is switched off to the whole unit.
3. A radio transmitter to be located in or near an area where mobile communication units must not radiate radio frequency energy, wherein the radio transmitter is adapted to transmit a power shut-down signal to be received by a detector in a mobile communication unit within said area, the detector being adapted, upon reception of the power shut-down signal, to generate a power-down signal to be supplied to a power source of the mobile communication unit to control the power source to switch off power to at least radio frequency emitting parts of the mobile communication units.
4. A radio transmitter according to claim 3, wherein the radio transmitter is adapted to transmit, together with the power shut-down signal, a coded message to be validly decoded by a decoder in the mobile communication unit before said power-down signal is supplied.



