

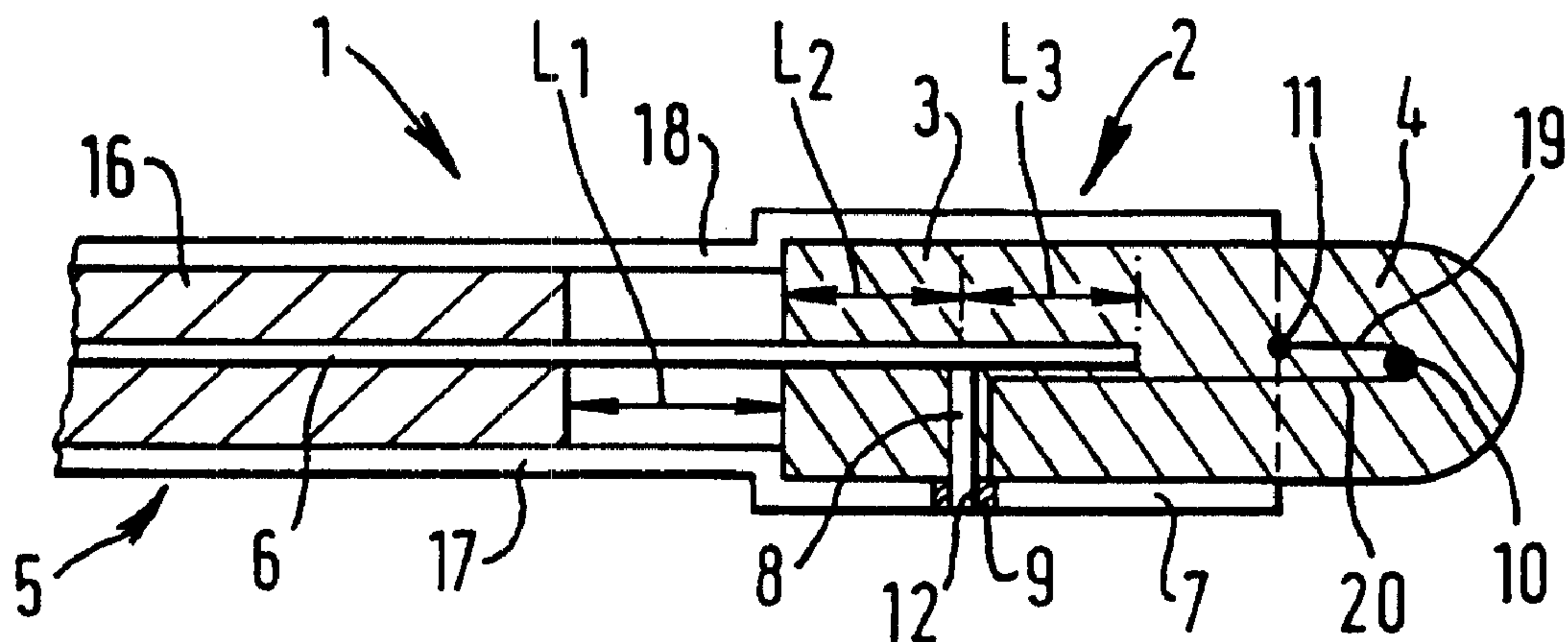

(72) CRONIN, NIGEL, GB
(71) MICROSULIS PLC, GB
(51) Int.Cl.⁶ A61B 17/36, H01Q 13/24
(30) 1998/05/06 (9809539.1) GB
(54) **APPLICATEUR HYPERFREQUENCE**
(54) **MICROWAVE APPLICATOR**



(57) A microwave applicator for applying electromagnetic radiation at microwave frequency comprises a coaxial input (5) for a microwave signal input, a waveguide (2) for receiving and propagating the microwave signal input, dielectric material (3) positioned within the waveguide (2) and extending beyond the waveguide to form an antenna (4) for radiating microwave energy, characterised in that the coaxial input (5) has direct in-line transition to the dielectric-filled waveguide. Preferably, this direct in-line transition is achieved by the central conductor (6) of the coaxial input extending axially centrally into the waveguide (2) so as to excite microwaves in the waveguide. A lateral conductor (8) extends radially from the central conductor (6) to assist the launch of the microwaves into the waveguide. Preferably, the applicator includes a temperature sensor (10) which is directly connected to the coaxial input (5).

PCT

WORLD INTELLECTUAL PROPERTY ORGANIZATION
International Bureau

INTERNATIONAL APPLICATION PUBLISHED UNDER THE PATENT COOPERATION TREATY (PCT)

<p>(51) International Patent Classification⁶ : A61B 17/36, H01Q 13/24</p>	<p>A1</p>	<p>(11) International Publication Number: WO 99/56642 (43) International Publication Date: 11 November 1999 (11.11.99)</p>
<p>(21) International Application Number: PCT/GB99/01398 (22) International Filing Date: 5 May 1999 (05.05.99) (30) Priority Data: 9809539.1 6 May 1998 (06.05.98) GB (71) Applicant (for all designated States except US): MICROSULIS PLC [GB/GB]; 11b Dragoon House, Hussar Court, Westside View, Waterlooville, Hampshire P07 7SF (GB). (72) Inventor; and (75) Inventor/Applicant (for US only): CRONIN, Nigel [GB/GB]; 14 Englishcombe Lane, Bath BA2 2ED (GB). (74) Agent: HOGG, Jeffery, Keith; Withers & Rogers, Goldings House, 2 Hays Lane, London SE1 2HW (GB).</p>	<p>(81) Designated States: AE, AL, AM, AT, AU, AZ, BA, BB, BG, BR, BY, CA, CH, CN, CU, CZ, DE, DK, EE, ES, FI, GB, GD, GE, GH, GM, HR, HU, ID, IL, IN, IS, JP, KE, KG, KP, KR, KZ, LC, LK, LR, LS, LT, LU, LV, MD, MG, MK, MN, MW, MX, NO, NZ, PL, PT, RO, RU, SD, SE, SG, SI, SK, SL, TJ, TM, TR, TT, UA, UG, US, UZ, VN, YU, ZA, ZW, ARIPO patent (GH, GM, KE, LS, MW, SD, SL, SZ, UG, ZW), Eurasian patent (AM, AZ, BY, KG, KZ, MD, RU, TJ, TM), European patent (AT, BE, CH, CY, DE, DK, ES, FI, FR, GB, GR, IE, IT, LU, MC, NL, PT, SE), OAPI patent (BF, BJ, CF, CG, CI, CM, GA, GN, GW, ML, MR, NE, SN, TD, TG).</p> <p>Published <i>With international search report. Before the expiration of the time limit for amending the claims and to be republished in the event of the receipt of amendments.</i></p>	

(54) Title: MICROWAVE APPLICATOR

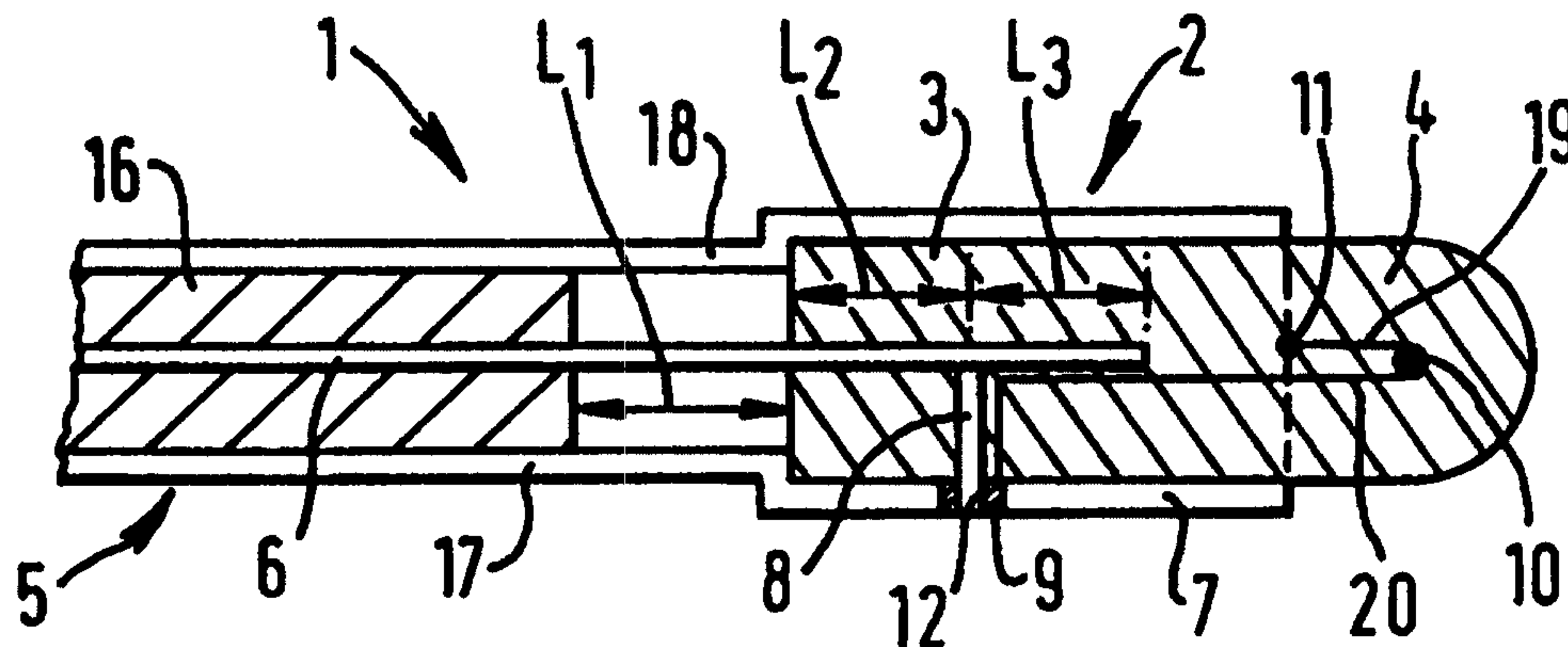

(57) Abstract

A microwave applicator for applying electromagnetic radiation at microwave frequency comprises a coaxial input (5) for a microwave signal input, a waveguide (2) for receiving and propagating the microwave signal input, dielectric material (3) positioned within the waveguide (2) and extending beyond the waveguide to form an antenna (4) for radiating microwave energy, characterised in that the coaxial input (5) has direct in-line transition to the dielectric-filled waveguide. Preferably, this direct in-line transition is achieved by the central conductor (6) of the coaxial input extending axially centrally into the waveguide (2) so as to excite microwaves in the waveguide. A lateral conductor (8) extends radially from the central conductor (6) to assist the launch of the microwaves into the waveguide. Preferably, the applicator includes a temperature sensor (10) which is directly connected to the coaxial input (5).

MICROWAVE APPLICATOR

Technical Field

This invention relates to a microwave applicator for the treatment of a body by means of microwave electromagnetic energy. The body is preferably biological tissue and, preferably, the applicator is for use in the treatment of menorrhagia.

Menorrhagia is a common condition in women over the age of forty and manifests itself as excessive bleeding from the endometrium which constitutes the inner wall of the uterus.

The most common form of treatment is to carry out a hysterectomy in which the entire uterus is removed.

In our earlier application published under number WO95/04385, the contents of which are incorporated herein by reference, we disclosed a probe for applying electromagnetic radiation at microwave frequency which comprised a dielectric-filled waveguide with an exposed portion at the tip defining an antenna. However, in several of the embodiments, the microwaves were launched in a first air-filled waveguide and then the microwaves were passed into a second waveguide which contained the dielectric material. Between the waveguides, a tapered waveguide provided a transition. The dielectric filled waveguide was of smaller diameter than the air-filled waveguide because, at a given frequency, the wavelength in dielectric is shorter. Hence the diameter of the applicator in wavelengths remains constant throughout transition.

However, although such a applicator is perfectly satisfactory, the applicator bandwidth is compromised by the resonance found in the long length of dielectric filled waveguide. This means that any change in frequency generated by the microwave source could make a significant difference in applicator efficiency.

Disclosure of the Invention

According to the present invention, there is provided a microwave applicator for applying electromagnetic radiation at microwave frequency comprising a coaxial input for receiving and passing a microwave signal input of predetermined frequency, a waveguide for receiving and propagating the microwave signal input, dielectric material positioned within the waveguide and extending beyond the waveguide to form an antenna for radiating

14-06-2000

GB 009901398

P100767PCT

2

microwave energy, characterised in that the coaxial input has means for providing a direct, in-line transition of the microwave signal input into the dielectric-filled waveguide.

Preferably, this direct in-line transition is achieved by the central conductor of the coaxial input extending axially centrally into the waveguide so as to excite microwaves in the waveguide. A lateral conductor extends radially from the central conductor towards the outer wall of the waveguide and serves to assist the launch of the microwaves into the waveguide in the appropriate mode for transmission to the tip.

Preferably, the applicator includes a temperature sensor which is directly connected to the coaxial input to minimise wiring.

Suitably, where the applicator is to be used for medical treatment such as endometrial ablation, it is important that the applicator be sterile for each use. Accordingly, preferably the applicator is coated with a microwave transparent coating allowing the applicator to be cleaned in conventional manner.

Although the microwave applicator of the present invention may be used for any desired application, it is preferred that it be used for endometrial ablation. This requires applying microwave energy to the applicator at a frequency which will be substantially completely absorbed by the endometrium, monitoring the operating temperature to ensure that the endometrium tissue is coagulated evenly through the uterine cavity, thus maintaining the application of the microwave energy for a period of time sufficient to destroy the cells of the endometrium.

The use of microwave power to heat the endometrium has two main advantages. Firstly, electromagnetic radiation at microwave frequencies is strongly absorbed by tissue and at around 8-12GHz all microwave power is absorbed in a layer of tissue about 5mm thick and it is impossible for microwave heating to extend beyond this region. This is ideal for the treatment of the endometrium which is about 5mm thick. Secondly, because of this strong absorption, the amount of power required to achieve the desired temperature is relatively small.

2a

Moreover, the improved applicator of the present invention has the following major advantages over the applicator previously disclosed in our aforementioned earlier application:

- (i) the waveguide is shorter because, by forming a hybrid between a coaxial input and a dielectric filled waveguide, the distance between the transition and the radiating tip is

very much shorter. This, in turn, reduces the amount of dielectric material necessary which improved band width and applicator efficiency; and

(ii) it is possible to make the applicator flexible.

Description of the Drawings

The invention will now be described by way of example with reference to the accompanying drawings, in which:

Figure 1 is a diagrammatic side elevation of a preferred microwave applicator in accordance with the invention; and

Figure 2 is a diagrammatic plan view of the waveguide of Figure 1 showing the microwave fields.

In Figure 1, a microwave applicator (1) has a circular section waveguide (2) filled with a dielectric material (3). The waveguide (2) terminates short of the end of the applicator (1) and a portion (4) of the dielectric extends therefrom to form a radiating antenna tip for the microwave energy. That end of the waveguide remote from the tip (4), is connected to a coaxial cable (5) that powers the waveguide. The inner conductor (6) of the cable (5) extends axially into the dielectric (3) along the axis of the waveguide (2) so as to directly excite microwaves in the waveguide (2). The outer conductor (17) of the cable (5) is connected to the outer conductor wall (7) of the waveguide. The conductor (6) terminates within the waveguide, and a lateral conductor (8) extends radially from the conductor (6) through the outer wall (7) and serves to cause the microwaves to launch into the dielectric material (3) with the magnetic fields (14) and electric fields (15) orientated as shown in Figure 2.

The coaxial cable (5) may be air-filled, but as illustrated in Figure 1, it is filled with a dielectric (16), but this terminates short of the dielectric (3) of the waveguide (2) so as to leave an air gap (18) that accommodates axial expansion of the dielectric (16) when the applicator is heated in use, either during treatment or sterilisation.

The axial dimension L_1 of the air-gap (18), and the axial dimensions L_2 and L_3 of the conductor 6 within the waveguide(2) either side of the conductor (8), are all selected to tune out the reactance of the loop formed by the conductor (8), and thereby reduce backward reflections and enhance forwards launching of the microwaves in the waveguide.

The conductor (8) is insulated by insulation (9) as it passes through the outer waveguide wall (7).

Also shown in Figure 1 is a thermocouple (10) on the outside of the radiating tip (4) for sensing the operating temperature. Moreover, in order to avoid additional wiring, the thermocouple (10) is directly connected by a connection 19 to the outer conductor (17) of the coaxial cable (5) at (11) and by a connection (20) outside the wall (7) to the central conductor (6) of the cable (5) via the lateral conductor (8) and a connection (12) at its outer end. Accordingly, the thermocouple signal passes out on the same coaxial cable (5) bringing the microwave power to the radiating tip (4). Conventional circuitry (not shown) is used to sense and extract the DC signal from the coaxial cable.

Although not shown, the applicator (1) is provided with a microwave-transparent protective coating of PTFE or other suitable material. The temperature sensing thermocouple (10) is provided between the coating and the dielectric material as well as being insulated from the dielectric material.

The preferred use of the applicator of the present invention as disclosed in our aforementioned published application number WO95/04385 where the applicator is supplied with a microwave frequency input in the microwave spectrum, preferably in the region of 8-12GHz, from a microwave frequency generator source and amplifier.

Claims

1. A microwave applicator (1) for applying electromagnetic radiation at microwave frequency comprising a coaxial input (5) for receiving and passing a microwave signal input of predetermined frequency, a waveguide (2) for receiving and propagating the microwave signal input, dielectric material (3) positioned within the waveguide and extending beyond the waveguide to form an antenna (4) for radiating microwave energy, characterised in that the coaxial input (5) has means for providing a direct, in-line transition of the microwave signal input into the dielectric-filled waveguide.
2. A microwave applicator (1) as claimed in claim 1, in which a central conductor (6) of the coaxial input (5) extends axially centrally into the dielectric material (3) of the waveguide (2).
3. A microwave applicator (1) as claimed in claim 2, in which the conductor (6) terminates within the waveguide (2) and a lateral conductor (8) extends radially therefrom.
4. A microwave applicator (1) as claimed in claim 3, in which the lateral conductor (8) is located midway along the length of the conductor within the waveguide (2).
5. A microwave applicator (1) claimed in claim 4 in which the conductor (8) extends through an aperture in the waveguide wall (7) and is electrically insulated from the wall (7).
6. A microwave applicator (1) as claimed in any one of the preceding claims, in which the coaxial input (5) is a dielectric filled cable in which the dielectric (16) terminates short of the waveguide to leave an air-gap (18).
7. A microwave applicator (1) as claimed in any of the preceding claims, in which a sensor is mounted on it, and the sensor signal output is connected to the coaxial input.
8. A microwave applicator (1) as claimed in any one of the preceding claims which is adapted for medical use.
9. A microwave applicator (1) as claimed in claim 8 which is an ablator.

1 / 1

FIG. 1.

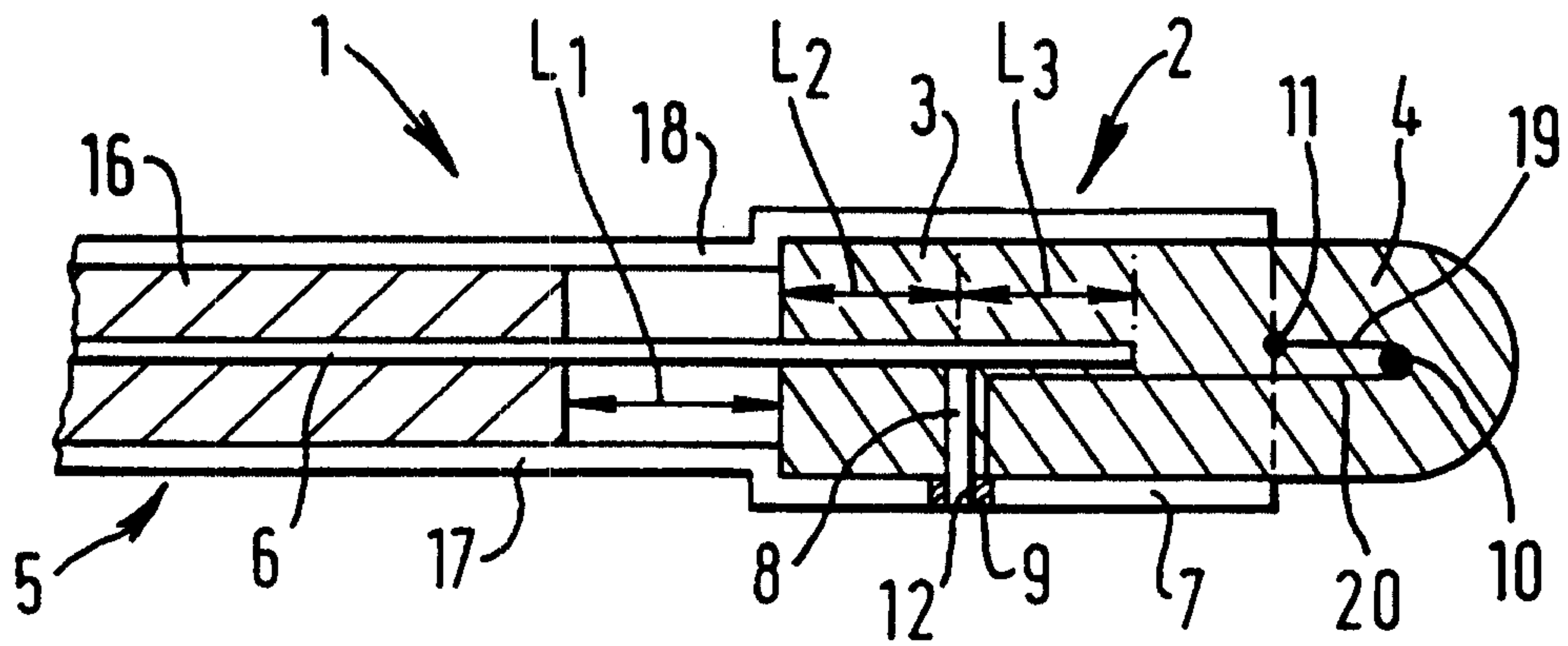

FIG. 2.

