

L. O. MAKEPEACE.

Improvement in Boot and Shoe Crimping-Machine.

No. 131,288.

Patented Sep. 10, 1872.

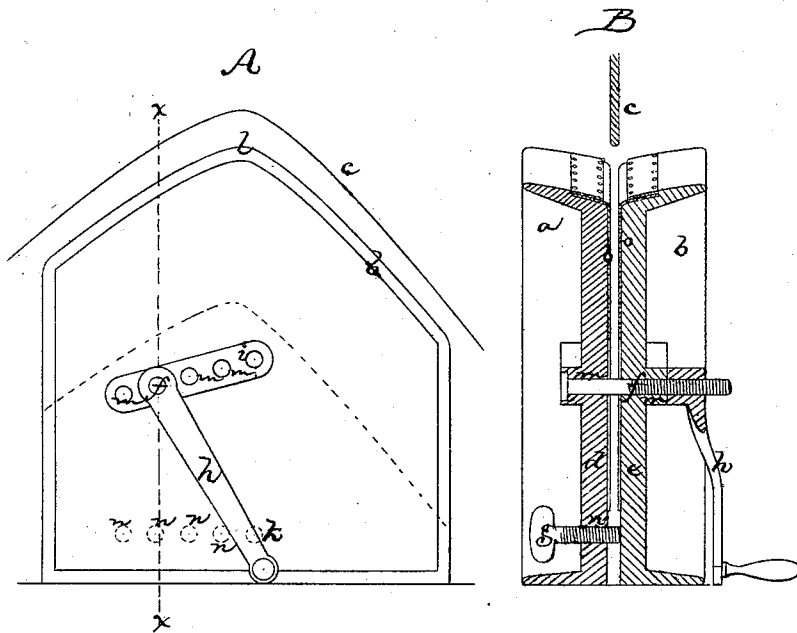

Witnesses.
No. W. Frothingham.
L. H. Cratimer.

Inventor.
Lyander O. Makepeace.
By his Attys.
Crosby & Gould.

UNITED STATES PATENT OFFICE.

LYSANDER O. MAKEPEACE, OF WORCESTER, MASSACHUSETTS.

IMPROVEMENT IN BOOT AND SHOE CRIMPING-MACHINES.

Specification forming part of Letters Patent No. 131,288, dated September 10, 1872.

To all whom it may concern:

Be it known that I, LYSANDER O. MAKEPEACE, of Worcester, in the county of Worcester and State of Massachusetts, have invented an Improvement in Boot and Shoe Crimping-Machines; and I do hereby declare that the following, taken in connection with the drawing which accompanies and forms part of this specification, is a description of my invention sufficient to enable those skilled in the art to practice it.

My invention relates to that class of crimping-machines in which two stationary crimping-jaws are employed, in combination with a movable follower that drives the boot or shoe upper down between the jaws, and crimps or forms the leather. The extent of opening movement of the jaws is governed and determined by two bolts, one extending through and connecting the jaws about half way down and in a center line, and the other extending through one of the jaws in the same vertical line near the bottom of the jaws, the lower bolt being a set-screw, by turning which the jaws are forced apart or permitted to close toward each other at the point where the screw passes through the jaw-plate, one of the jaws slipping upon the bolt, the extent of movement of the jaw being controlled by a nut or a nut-threaded winch that works on the screw-bolt. The jaws thus made and connected answer their purpose perfectly in crimping boot-legs where the length of leg about equals the length of foot, one part entering the jaws on one side of the center or angle of the jaws, and the other part at the other side thereof. But when the length of foot greatly exceeds the length of leg, or when there is only a vamp or foot portion to crimp, the jaws fail to crimp or to equally crimp, because, being hung or connected at the center line, and the leather entering on one side of the center line, the strain of the leather opens the jaws at the entering side of the center by closing them at the opposite side, there being nothing to prevent such closing.

The object of my invention is to obviate this difficulty, and I accomplish the desired result by making provision for adjustment of the jaw connections so that an equal open

movement may be insured no matter what may be the length of line to be crimped. This provision consists in forming the jaws with a series of bolt-receiving holes, by means of which the bolts may be set at various positions in accordance with the shape of the uppers to be crimped.

My invention consists in this provision for adjustment of the jaw connections.

The drawing represents a pair of crimping-jaws embodying the invention.

A shows a side elevation of the jaws; B, a section on the line xx . $a b$ denote the stationary jaws of the crimper; c , the follower that presses the boot or shoe top down between the jaws to crimp it. The jaws are stationary as to the movement of the follower, but they have provision for relative adjustment, the jaw-plates $d e$ being connected and their extent of opening regulated by a screw-bolt, f , and set-screw g . The set-screw g works through a nut-thread in the plate d , and its inner end abuts against the inner surface of the plate e ; and the bolt f is a connecting-screw passing through and connecting both plates, the jaws being forced in by turning the handle h , that works on the screw f . i denotes the hole usually made for reception of the bolt f , and k the hole usually made for reception of the bolt g , the holes $i k$ being in vertical line and at the center of the jaws, or directly under the angle l . But instead of making the connections invariably at these holes, I form a series of other holes, m , for reception and change of position of the bolt f , and a second series of holes, n , for reception and change of position of the bolt g , and by setting the bolts in any two of these holes in vertical line equal opening of the jaws may be produced with any form of upper, the bolts being located in accordance with the extent and position of the line upon which the crimping is to be effected. For the set-screw g the series of holes is essential, but for the connecting-bolt f a slot in each plate may be made.

In crimping certain kinds of stock the jaw-faces, if rigid, fail to take hold of the leather evenly, on account of variation in thickness of the stock. To remedy this, I form each jaw with an elastic face, o , made of caout-

chouc or similar elastic material, the yielding nature of which enables the face of the jaw to fit the stock at all points.

I claim—

The jaws *a b*, connected and set by bolts or screws *f g*, the jaws being made with bolt-holes or slots for change or adjustment of such

bolts or screws, substantially as shown and described.

LYSANDER O. MAKEPEACE.

Witnesses:

FRANCIS GOULD,
M. W. FROTHINGHAM.