

*B. C. Davis.*

*Trimming Blind Rods.*

*N<sup>o</sup> 103,848.*

*Patented Jun. 7, 1870.*

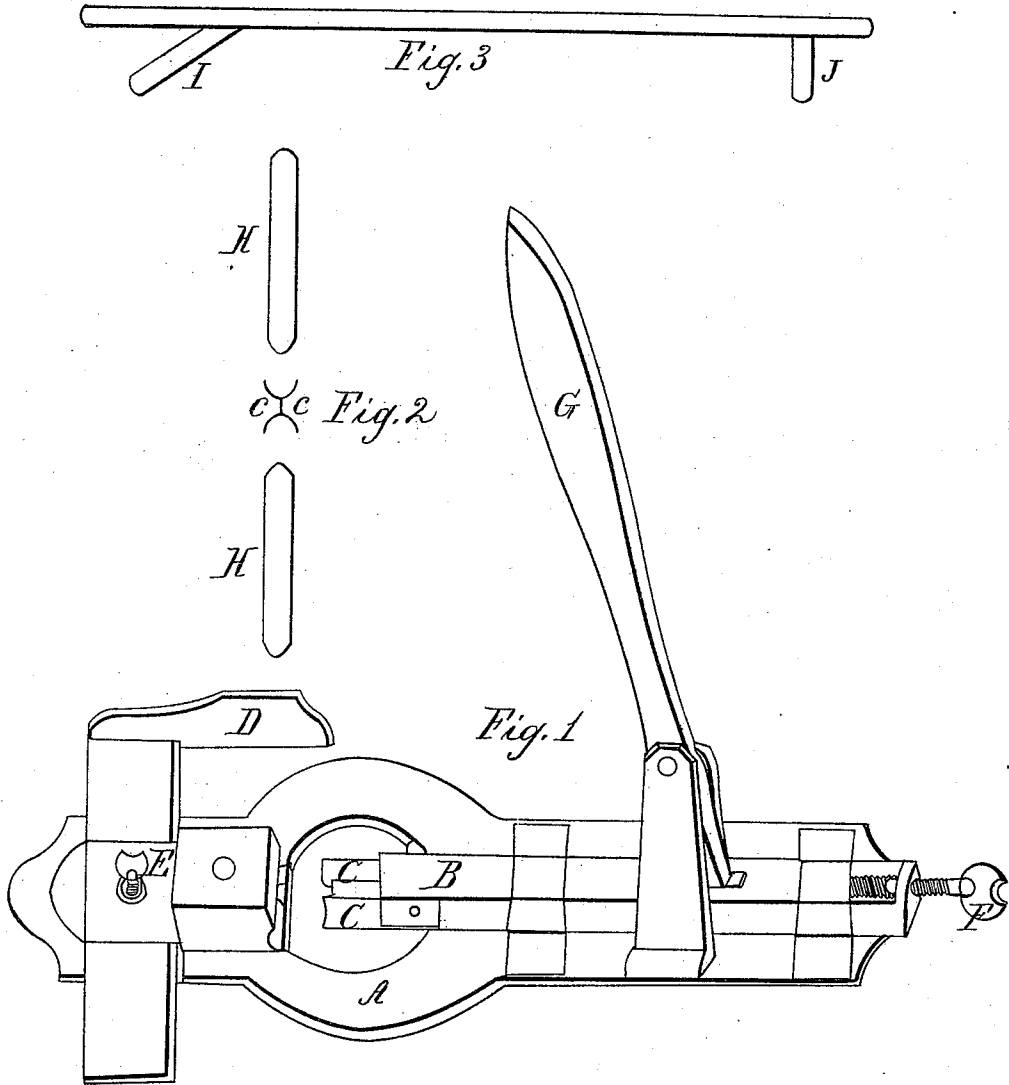

*Witnesses*  
*Wm M. DeLong.*  
*S. W. Rogers*

*Inventor*  
*Biram C. Davis.*

# United States Patent Office.

BIRAM C. DAVIS, OF BINGHAMTON, NEW YORK.

Letters Patent No. 103,848, dated June 7, 1870.

## IMPROVEMENT IN MACHINE FOR TRIMMING BLIND-RODS.

The Schedule referred to in these Letters Patent and making part of the same.

I, BIRAM C. DAVIS, of Binghamton, in the county of Broome, State of New York, have invented a new and useful Machine for Cutting and Trimming Blind-Rods, of which the following is a specification.

The nature of my invention consists in the combination and arrangement of devices for trimming blind-rods, hereinafter set forth, all arranged in such a manner as to be capable of trimming the ends of window-blind rods, or cutting the material for the rods to the lengths the operator may desire, and finishes the ends of the blind-rod.

The object is to facilitate this class of work in a better manner than heretofore.

### *Description of the Accompanying Drawing.*

Figure 1 is a perspective view of the machine, as shown, ready for use.

Figure 2 is a view showing the shape of the cutters and blind-rod with the finished oval-shaped ends.

### *General Description.*

A is the bed-piece of the machine, which has guides for the reception of a bolt and gauge, and also a block of hard wood securely fixed therein. Said bed-piece should be made of cast-iron.

B is the bolt, to which the cutter-knives are secured at its front end, and is provided with a mortise at its center for the reception of the end of the lever G. This bolt should be made of wrought-iron, and it operates in guides on the bed-piece A.

C C is the curved or gouge-shaped cutters, which should be made from the best of steel, and are secured firmly with a screw-bolt to the front end of the bolt B.

D is the gauge-rod, to be adjusted for gauging the blind-rod to such lengths as desired. Said gauge-rod should be made of hard wood, and it operates in a guide on the bed-piece A at right angles with the bolt B.

E is the set-screw by which the gauge-rod D is secured firmly for operation.

F is the adjustable screw, which passes through the projecting ear on the back end of the bolt B. This screw is for regulating the cutter-knives C C, to allow them to penetrate, as desired, the end of a block of wood that is secured in the bed-piece A. This wood is recessed to the precise shape of one-half of the blind-rod, being for the rod H H to rest in, at right angle with the bolt B, while the cutters C C are trimming or cutting the same to their lengths.

G is the lever, which should be at least one foot long, and made of cast-iron. Its lower end fits into the mortise in the center of the bolt B, and hinged at a short fulcrum between the projecting ears or parts on the bed-piece A.

To operate this machine, I first secure it firmly to a work-bench, and see to the cutters that they have a sharp edge. I then set the gauge-rod D to the length of the blind-rod I wish to cut. I then place one end of the material for the blind-rod in the gap or recess, as described above. I then take hold of the lever G with my right hand, and, with a pulling motion, I force the cutters C C through the rod against the end of a block of wood, trimming one end of the blind-rod; then the lever G is brought back by a pushing motion. I then pass the blind-rod along to the gauge D, the operation of the lever repeated, which cuts the blind-rods to the length desired, as shown in fig. 2, with the ends finished as they pass from the machine.

I claim the combination of the bed-piece A, bolt B, cutters C C, gauge-rod D, and lever G, the whole being constructed and arranged as shown and described for the purpose set forth.

BIRAM C. DAVIS.

Witnesses:

WM. M. DELONG,  
S. W. ROGERS.