



(12) EUROPEAN PATENT APPLICATION

(43) Date of publication:
22.02.2006 Bulletin 2006/08

(51) Int Cl.:
F04B 27/18^(2006.01)

(21) Application number: 05017519.9

(22) Date of filing: 11.08.2005

(84) Designated Contracting States:
AT BE BG CH CY CZ DE DK EE ES FI FR GB GR
HU IE IS IT LI LT LU LV MC NL PL PT RO SE SI
SK TR
Designated Extension States:
AL BA HR MK YU

(72) Inventor: Yoshihiro, Ryosuke
Hachioji-shi
Tokyo 193-0942 (JP)

(74) Representative: Grünecker, Kinkeldey,
Stockmair & Schwanhäusser
Anwaltssozietät
Maximilianstrasse 58
80538 München (DE)

(30) Priority: 19.08.2004 JP 2004239161

(71) Applicant: TGK CO., Ltd.
Hachioji-shi,
Tokyo 193-0942 (JP)

(54) Control valve for variable displacement compressor

(57) A control valve for performing a Pd- P_s differential pressure control method in a variable displacement compressor adjusts the difference between an effective pressure-receiving area A on a discharge pressure side of an intermediate structure in which a valve element 14 is made to move in unison with a shaft 18 and an effective pressure-receiving area B on a suction pressure side of the intermediate structure, as required. This allows to obtain desired "differential pressure · crank pressure characteristics" according to the specifications of the control valve. Changes in the effective pressure-receiving areas have almost no influence on "electric current · differential pressure characteristics", i.e. the relationship between the value of the supplied electric current and the differential pressure ($P_d - P_s$), and hence it is possible to realize the changes in the effective pressure-receiving areas A, B with ease.

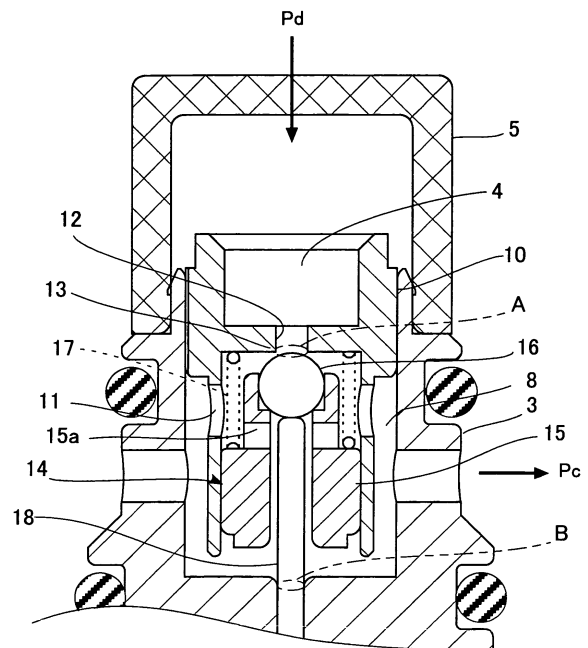

FIG. 2

Description

[0001] The invention relates to a control valve according to the preamble of claim 1, particularly for controlling the compressor discharge capacity in an automotive air conditioner.

[0002] Variable displacement compressors in automotive air conditioners capable of changing the refrigerant discharge capacity are generally employed so as to obtain an adequate refrigerating capacity without being constrained by the rotational speed of an engine driving the compressor.

[0003] In a known variable displacement compressor, a swash plate driven by the engine via a shaft for performing a wobbling motion is disposed within a crankcase such that the inclination angle of the swash plate can be changed. Pistons are reciprocatingly driven by the swash plate draw in order to refrigerant from a suction chamber into cylinders, to compress and to discharge compressed refrigerant into a discharge chamber. The inclination angle changing the discharge capacity is varied by changing the pressure in the crankcase. A control valve controls the pressure in the crankcase.

[0004] A known control valve decompresses refrigerant at discharge pressure P_d to introduce the decompressed refrigerant into the crankcase, and controls the pressure P_c (crankcase pressure) by controlling the amount of introduced refrigerant. External electric current is supplied to a solenoid of the control valve for the actuation of a valve element, specifically, by a method based on the value of a suction pressure P_s in the suction chamber, for example. The control valve senses the suction pressure P_s , and controls the flow rate into the crankcase such that the suction pressure P_s is maintained at a predetermined level. The value of suction pressure P_s at which the variable displacement operation is to be started can be freely set by the electric current. However, it then is necessary to provide a movable flexible member, such as a diaphragm or a bellows, for sensing the suction pressure P_s , which undesirably increases the dimension of the control valve.

[0005] To eliminate the inconvenience, it is known from JP 2003 328936 A to perform a control based on the differential pressure ($P_d - P_s$) between the discharge pressure P_d and the suction pressure P_s ("the P_d - P_s differential pressure control"). The differential pressure ($P_d - P_s$) is sensed and the flow rate into the crankcase is controlled such that the differential pressure ($P_d - P_s$) is maintained at a predetermined level. In the control valve an effective pressure-receiving area of an intermediate structure, e.g. a valve element and a piston rod, loaded by the discharge pressure P_d , and an effective pressure-receiving area of the intermediate structure loaded by the suction pressure P_s are equal such that the influence of the crankcase pressure P_c is cancelled. A valve section performs an opening/closing operation initiated by the differential pressure ($P_d - P_s$), irrespective of the crankcase pressure P_c . In this case, the dis-

charge pressure P_d and the suction pressure P_s directly load the valve element for sensing the differential pressure, and hence it is possible to dispense with the above-mentioned flexible member. Particularly, since the discharge pressure P_d is directly sensed, it is possible to truly reflect any change in pressure of the variable displacement compressor, and hence to obtain a displacement control with excellent response. However, actually, the crankcase pressure P_c is increased by increasing the value of the differential pressure ($P_d - P_s$), and conversely the value of the differential pressure ($P_d - P_s$) as well is varied to some extent by variations in the crankcase pressure P_c , etc. More specifically, as the crankcase pressure P_c increases, the value of the differential pressure ($P_d - P_s$) increases as well with a slight slope or ramp characteristic, for example. Although this phenomenon may not be ideal when considering only the characteristics of the control valve, this is not always true when considering matching between "the P_d - P_s differential pressure control" performed by the control valve and the control of the variable displacement compressor itself. More specifically, when the differential pressure ($P_d - P_s$) instantaneously rises to a fixed value in response to a change in the value of electric current supplied to the solenoid, the valve section instantaneously will open, which enhances the response of the swash plate but nevertheless sometimes causes hunting or overshooting in the displacement control. This makes it difficult to stably perform the displacement control. When the value of the differential pressure ($P_d - P_s$) slowly rises, the response of the swash plate is degraded. Further, even with the same current value, the value of the differential pressure ($P_d - P_s$) to be controlled varies with the value of the crankcase pressure P_c . This sometimes leads to a hysteresis of the displacement control, and hence then is not preferable for the control of the variable displacement compressor. Therefore, it is considered preferable to cause the differential pressure ($P_d - P_s$) to rise with a proper response (slope) according to the value of the electric current. For example, when the swash plate is difficult to move, it is required to increase the response to promote the required motion of the swash plate, whereas when the swash plate is excessively easy to move, it is required to lower the response to stabilize the motion of the swash plate. To this end, the degree (slope) of the influence of the crankcase pressure P_c on a change in the differential pressure ($P_d - P_s$) has conventionally been adjusted e.g. by changing the characteristic of a spring which urges the valve element in one moving direction, or by changing the attractive force characteristic of the solenoid according to characteristics required of the control valve. However, when the characteristic of the spring or the attractive force characteristic of the solenoid is changed, the differential pressure characteristics, i.e. the relationship between the value of the electric current and the value of the differential pressure ($P_d - P_s$) may also change, which makes it difficult to perform a total tuning operation.

[0006] It is an object of the invention to provide a Pd-Ps differential pressure control method control valve for a variable displacement compressor, which allows to set characteristics concerning the degree of the influence of the crankcase pressure on a change in the differential pressure to desired characteristics with ease.

[0007] This object is achieved by the features of claim 1.

[0008] The feature "the plunger is made to move in unison with the valve element via the shaft", does not necessarily mean that the plunger needs to directly co-act with the shaft, but it even may co-act with the shaft via an interposed object formed separately from the shaft.

[0009] The effective pressure-receiving area on the discharge pressure side of the intermediate structure and the effective pressure-receiving area on the suction pressure side of the intermediate structure which are originally set equal to each other are intentionally configured such that the balance therebetween is lost. By adjusting the difference between these effective pressure-receiving areas, characteristics concerning the degree of the influence of the crank pressure on a change in the differential pressure ("the differential pressure • crank pressure characteristics") are adjusted such that they become desired characteristics. However, the effective pressure-receiving areas even may be equal in a boundary condition depending on the characteristics to be obtained.

[0010] It should be noted that changes in the effective pressure-receiving areas have almost no influence on the relationship between the value of the electric current supplied to the solenoid and the differential pressure ("the electric current • differential pressure characteristics").

[0011] Desired "differential pressure • crank pressure characteristics" can be obtained by adjusting the difference between the effective pressure-receiving area on the discharge pressure side of the intermediate structure formed by making the valve element and the shaft move in unison with each other, and the effective pressure-receiving area on the suction pressure side of the intermediate structure. Since the changes in the effective pressure-receiving areas have almost no influence on "the electric current • differential pressure characteristics", it is possible to obtain desired "differential pressure • crank pressure characteristics" with ease.

[0012] An embodiment of the invention will be described with reference to the drawings.

Fig. 1 is a cross-section of a control valve for a variable displacement compressor,

Fig. 2 is a fragmentary expanded cross-section of an upper part of the control valve, and

Figs 3A 3B, 3C contain diagrams explaining special characteristics of the control valve.

[0013] The control valve in Fig. 1 introduces flow rate controlled discharge refrigerant of a variable displacement compressor (not shown into the crankcase. The control valve integrally comprises a valve-forming section 1 containing a valve section, and a solenoid 2 for controlling the valve lift.

[0014] An open upper end of a stepped hollow cylindrical upper body defines a discharge pressure port 4 communicating with the compressor discharge chamber (discharge pressure Pd). A strainer 5 is capped on the upper body 3. The discharge pressure port 4 communicates with a crankcase pressure port 6 in a side of a central portion of the upper body 3. The crank pressure port 6 communicates with the crankcase (crank pressure). A suction pressure port 7 in a side of a lower portion of the upper body 3 communicates with the suction chamber (suction pressure Ps). A refrigerant passage 7a connected to the suction pressure port 7 changes direction downward inside the upper body 3.

[0015] A crankcase-communicating chamber 8 (crank pressure Pc) is formed between the ports 4, 6. An axially extending guide hole 9 in the centre of the lower portion of the upper body 3 axially guides a shaft 18. The guide hole 9 opens into the crankcase-communicating chamber 8. A stepped hollow cylindrical valve seat-forming member 10 is inserted into the crankcase-communicating chamber 8 from above.

[0016] As more clearly shown in Fig. 2, the outer upper periphery of the valve seat-forming member 10 is press-fitted into the open upper end of the upper body 3. A lower portion of the valve seat-forming member 10 extends downward through the crankcase-communicating chamber 8 with a diameter reduced by one step. This reduced diameter portion has communication holes 11 between the inside and the outside of the valve seat-forming member 10. An intermediate portion of an inner part of the valve seat-forming member 10 has a valve hole 12 interconnecting respective space on the discharge chamber and the crankcase sides. The lower rim of the valve hole 12 forms a valve seat 13 at the crankcase side.

[0017] A valve element 14 is axially movably disposed in a lower opening of the valve seat-forming member 10 and includes a holder 15 that can slide along an inner wall of the valve seat-forming member 10. A ball 16 is press-fitted into a central portion of the upper end of the holder 15. The outer periphery of an upper portion of the holder 15 is reduced in diameter and carries a spring 17 interposed between the valve seat-forming member 10 and the holder 15, for urging the ball 16 in a direction away from the valve seat 13. The holder 15 has communication holes 15a between the inside and the outside of the holder 15. The ball 16 operates in unison with the holder 15 such that it can be seated on the valve seat 13. The discharge pressure Pd introduced from the discharge pressure port 4 is decompressed by passing through a restriction flow passage between the ball 16 and the valve seat 13, whereby the crank pressure Pc is generated.

[0018] The shaft 18 is axially movably inserted into the guide hole 9 in Fig. 1. One shaft end extends through the holder 15 and abuts at the ball 16. The other shaft end extending downward from the upper body 3.

[0019] Since the shaft 18 abuts the valve element 14 not via the holder 15 but via the ball 16 which is disposed ahead of the holder 15 through which the shaft 18 extends, the valve element 14 acts based on the principle of a balancing toy. As a result, a lateral motion of the valve element 14 is suppressed, and hence the valve element 14 is capable of axially moving back and forth in a stable state in which lateral load is reduced. Further, since the lateral load on the valve element 14 generated upon axial movement of the valve element 14 is reduced, hysteresis is decreased in the opening and closing characteristics of the control valve and the lateral displacement of the valve element 14 is suppressed. As a result, complete closing of the valve element 14 can reliably be expected.

[0020] An upper open end of a lower body 19 is joined by caulking to a bottom portion of the upper body 3. A core 20 of a solenoid 2 is screwed to a lower end of the upper body 3. The core 20 has an axial central hole 21, an upper portion with communication holes 22 extending from the outer periphery with the central hole 21, and communication holes 23 in an upper end between the refrigerant passage 7a and the communication hole 22. With this configuration, the suction pressure P_s is received by one end, namely the lower end of the shaft 18.

[0021] A sleeve 24 with a stopper 25 in the form of a lid fitted in a lower opening of the sleeve 24 is disposed inside the lower body 19. An annular bearing member 26 is press-fitted into the stopper 25. The core 20 and a plunger 27 are arranged in the sleeve 24. The plunger 27 is rigidly fixed to a shaft 28. One shaft end extends through the core 20 with clearance into an opening in the lower end of the upper body 3. The other shaft end is supported by the bearing member 26. Movement of the plunger 27 relative to the shaft 18 is restricted in one axial direction by a stop ring 29 on the shaft 28. The plunger 27 is guided on the shaft 28 to move axially without contact with the sleeve 24. Springs 30, 31 are interposed between the core 20 and the plunger 27, and between the plunger 27 and the bearing member 26.

[0022] Arranged along the outer periphery of the sleeve 24 are a yoke 32, a solenoid coil 33, and a casing 34 surrounding the yoke 32 and the solenoid coil 33, which constitute the solenoid 2 together with the core 20 and the plunger 27. A handle 36 supporting a harness 35 is fitted in the casing 34 to close the lower end of the solenoid 2.

[0023] In the control valve in Fig. 1 the discharge pressure P_d acts on the ball 16 from above. The suction pressure P_s acts on the shaft 18 in abutment with the ball 16, from below, via the clearance between the upper body 3 and the shaft 28. If the diameter of the shaft 18 (i.e. the diameter of the guide hole 9) and the diameter of the valve hole 12 are equal, the effective discharge pres-

sure-receiving area of the ball 16 and the effective suction pressure-receiving area of the shaft 18 are equal as well. Therefore, the crank pressure P_c applied to an intermediate structure formed by making the valve element 14 and the shaft 18 move in unison with each other is cancelled. The ball 16 controlling the flow rate into the crankcase forms a differential pressure valve that operates by sensing the differential pressure between the discharge pressure P_d and the suction pressure P_s .

[0024] In the present embodiment, however, the difference between the above-mentioned effective pressure-receiving areas is adjusted e.g. by increasing only the dimension of one of them, whereby characteristics (differential pressure crank pressure characteristics) concerning the degree of the influence of the crank pressure on a change in the differential pressure between the discharge pressure and the suction pressure are adjusted such that they become desired characteristics. This adjustment will be described in detail hereinafter.

[0025] Without solenoid control current the discharge pressure P_d pushes open the ball 16 into a fully-open state. The crank pressure P_c in the compressor becomes closer to the discharge pressure P_d . The pressure difference across the pistons in the crankcase becomes a minimum. The inclination angle of the swash plate minimizes the piston stroke. The compressor operates with minimum capacity or minimum displacement.

[0026] With maximum control current supplied to the solenoid 2, the plunger 27 is attracted upwards by the core 20. The shafts 28 and 18 are pushed upward to place the ball 16 in a fully-closed state. Refrigerant flows from the crankcase via a fixed orifice into the suction chamber orifice. The crank pressure P_c is reduced to a value close to the suction pressure P_s . This maximizes the pressure difference across the pistons, causing an adjustment of an inclination angle of the swash plate which maximizes the piston stroke. The compressor shifts to maximum capacity operation.

[0027] During normal control a predetermined control current is supplied to the solenoid 2. The plunger 27 is attracted by the core 20 with an upward force according to the magnitude of the control current. The plunger 27 moves by a predetermined amount. This force serves as a set value of the control valve that operates as the differential pressure valve, i.e. senses the differential pressure ($P_d - P_s$) and controls the flow rate into the crankcase such that the value of the differential pressure is held at a value corresponding to the set value as set by the solenoid 2.

[0028] The control valve allows to obtain a desired "differential pressure • crank pressure characteristics" by adjusting the difference between the effective pressure-receiving area A on the discharge pressure side of the intermediate structure formed by making the valve element 14 move in unison with the shaft 18, like a one-piece structure, and the effective pressure-receiving area B on the suction pressure side of the intermediate structure, as shown in Fig. 2. It should be noted that the effective

pressure-receiving area A can be adjusted by adjusting the diameter of the valve hole 12. The effective pressure-receiving area B on the suction pressure side can be adjusted by adjusting the diameter of the shaft 18 (i.e. the diameter of the guide hole 9).

[0029] Fig. 3A represents a case where the effective pressure-receiving areas A, B are equal. Fig. 3B represents a case where the effective pressure-receiving area A is smaller than the effective pressure-receiving area B. Fig. 3C represents the case where the effective pressure-receiving area A is larger than the effective pressure-receiving area B.

[0030] In Fig. 3A the differential pressure ($P_d - P_s$) is slightly changed under the influence of the crank pressure P_c even when the value of the supplied electric current is fixed. The differential pressure ($P_d - P_s$) varies with the magnitude of the value (I_{sol}) of the electric current.

[0031] More specifically, as A and B are equal originally, the influence of the crank pressure P_c should be cancelled and the differential pressure ($P_d - P_s$) should assume a predetermined value, irrespective of the crank pressure P_c . But actually, it is difficult to completely eliminate the influence of the crank pressure P_c , and in Fig. 3A there appears a slight slope in the characteristics.

[0032] In Fig. 3B, (A smaller than B), the balance of actions of the crank pressure P_c on the intermediate structure formed by making the valve element 14 move in unison with the shaft 18 is lost, and the degree of a contribution of the crank pressure P_c in valve-opening direction becomes larger. The valve section is easier to open. As a result, the differential pressure ($P_d - P_s$) rises promptly, and the influence of the crank pressure P_c becomes smaller than when A and B are equal, which enhances the response behaviour of the swash plate.

[0033] Also in Fig. 3C, (A larger than B), the balance of actions of the crank pressure P_c on the intermediate structure formed by making the valve element 14 integral with shaft 18 is lost, and the degree of a contribution of the crank pressure P_c in valve-closing direction becomes larger. The valve section then is more difficult to open. As a result, the differential pressure ($P_d - P_s$) will be slower, and the influence of the crank pressure P_c becomes larger than when A and B are equal, which lowers the response behaviour of the swash plate.

[0034] By adjusting the difference between A and B, it is possible to change the "differential pressure • crank pressure characteristics" of the control valve. Therefore, e.g. when the response behaviour of the swash plate is desired to be particularly enhanced compared with the characteristics of a conventional control valve, it is required that A becomes smaller than B. Inversely, when the response behaviour of the swash plate is desired to be lowered compared with the characteristics of the conventional control valve, it is only required that A becomes larger than B.

[0035] In the control valve according to the present invention, the difference between the effective pres-

sure-receiving area A on the discharge pressure side of the intermediate structure formed by making the valve element 14 integral with the shaft 18 and the effective pressure-receiving area B on the suction pressure side of the intermediate structure is adjusted as required. This allows to obtain desired "differential pressure • crank pressure characteristics" according to the specifications of the control valve. Such changes in the effective pressure-receiving areas have almost no influence on the "electric current • differential pressure characteristics", i.e. the relationship between the magnitude of the supplied electric current and the differential pressure ($P_d - P_s$), and hence it is possible to realize the changes in the effective pressure-receiving areas with ease.

Claims

1. A control valve for a variable displacement compressor, the control valve being mounted in the variable displacement compressor, for controlling a crank pressure (P_c) in a compressor crankcase to vary the refrigerant discharge capacity **characterised in that:**

a body (3) that has a discharge pressure port (4) for introducing the compressor discharge pressure (P_d), a crank pressure port (6) for delivering crank pressure (P_c) to the crankcase, and a suction pressure port (7), the discharge pressure port (4), the crank pressure port (6), and the suction pressure port (7) being sequentially arranged from one end of the body (3);

a valve element (14) is movably arranged in relation to a valve seat (13) provided between the discharge pressure port (4) and the crank pressure port (6), for reducing the discharge pressure by a restriction passage formed between the valve element (14) and the valve seat (13) to generate the crank pressure (P_c);

a shaft (18, 28) supporting the valve element (14) in valve-opening or valve-closing direction is arranged to operate in unison with the valve element (14); and

a solenoid (2) is connected to an end of the body (3) opposite to the discharge pressure port (4), the solenoid (2) comprising a core (20), a plunger (27) capable of moving in unison with the valve element (14) via the shaft (18, 28), and a solenoid coil (33)

further **characterised in that** the degree of the influence of the crank pressure (P_c) on a change in differential pressure ($P_d - P_s$) is adjusted by adjusting a difference between firstly an effective pressure-receiving area (A) of an intermediate structure placed for receiving the discharge pressure (P_d), the intermediate structure being formed by making the valve element (14)

move in unison with the shaft (18), and secondly an effective pressure-receiving area (B) of the intermediate structure placed for receiving the suction pressure (Ps).

- 5
2. The control valve according to claim 1, **characterised in that** a crankcase-communicating chamber (8) is defined between the valve seat (13) and the crank pressure port (6), the chamber (8) containing the generated crank pressure (Pc) and the valve element (14),
10
that a guide hole (9) for guiding the shaft (18) coaxial with a valve hole (12) defining the valve seat (13) is formed in the body (3) on a side of the chamber (8) opposite to the discharge pressure port (4),
15
that the shaft (18) is loaded by the suction pressure (Ps) on a side of the guide hole (9) opposite to the crankcase-communicating chamber (8),
that the effective pressure-receiving area (A) is adjusted by the size of the cross-sectional area of the valve hole (12), and
20
that the effective pressure-receiving area (B) is adjusted by the size of the cross-sectional area of the guide hole (9).
25
3. The control valve according to claim 2, **characterised in that** the effective pressure-receiving area (A) is configured to be larger than the effective pressure-receiving area (B) whereby the degree of the influence of the crank pressure (Pc) on the change in the differential pressure (Pd-Ps) is made larger than when the two effective pressure-receiving areas (A, B) are equal.
30
4. The control valve according to claim 2, **characterised in that** the effective pressure-receiving area (A) is configured to be smaller than the effective pressure-receiving area (B), whereby the degree of the influence of the crank pressure (Pc) on the change in the differential pressure (Pd-Ps) is made smaller than when the two effective pressure-receiving areas (A, B) are equal.
35
40
45
50
55

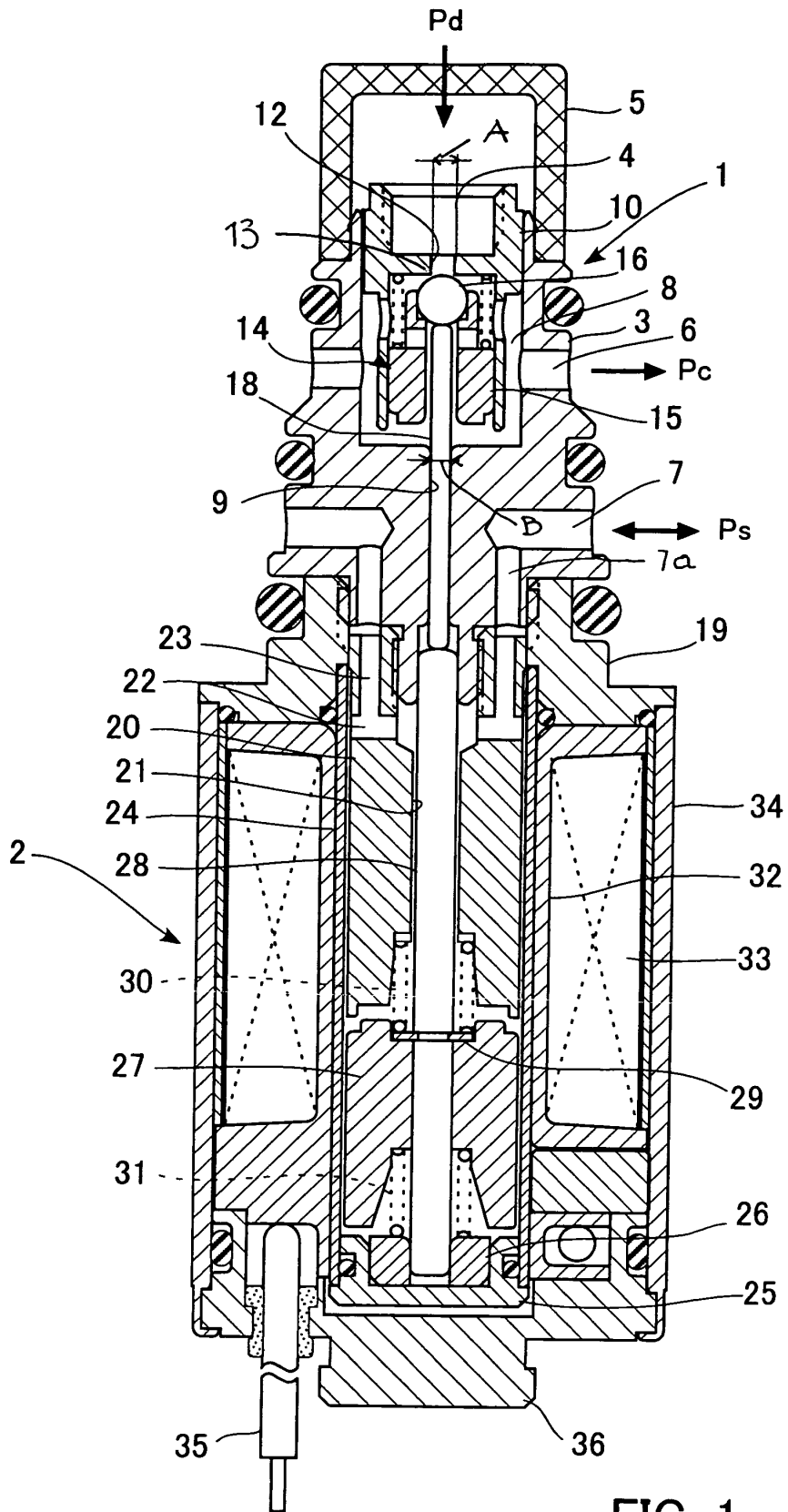

FIG. 1

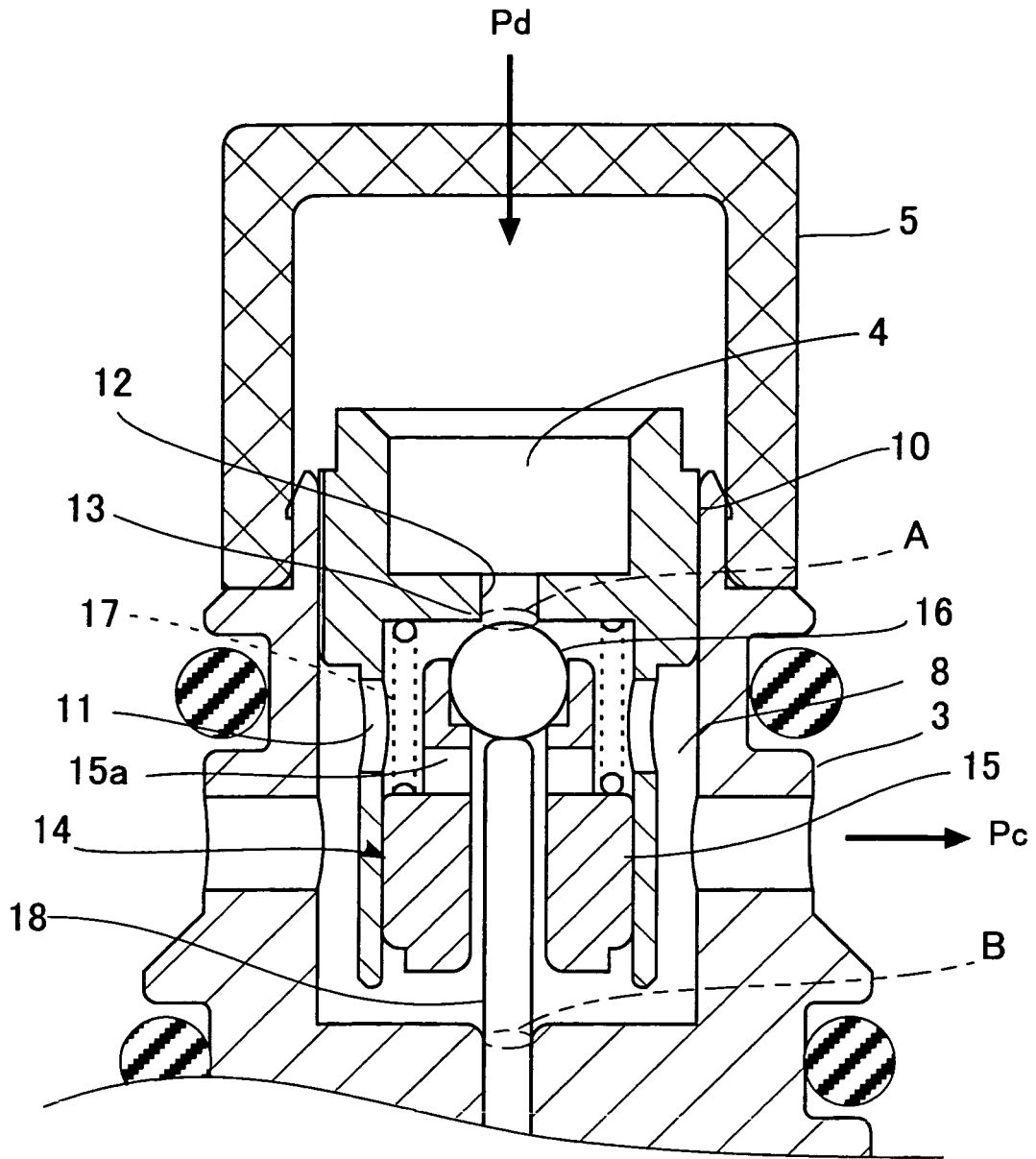

FIG. 2

