

AUSTRALIA  
Patents Act 1990

**PATENT REQUEST : STANDARD PATENT**

I, being the person identified below as the Applicant, request the grant of a Standard Patent to the person identified below as the Nominated Person, for an invention described in the accompanying complete specification.

**Applicant and**

**Nominated Person:** Horst BORMET  
**Address:** MITTELSTR. 8  
D-6108 WEITERSTADT  
GERMANY

**Invention Title:** SCREENING RAKE

**Names of Actual**

**Inventors:** HORST BORMET; ERICH FINK

**Address for Service:** GRIFFITH HACK & CO  
509 ST KILDA ROAD  
MELBOURNE VIC 3004

**Attorney Code:** HA

**BASIC CONVENTION APPLICATION DETAILS**

<b>Application No:</b>	<b>Country:</b>	<b>Application Date:</b>
G9104 551.7U	DE	13 April 1991
PCT/EP92/00186	PCT/EP	29 January 1992

Drawing number recommended to accompany the abstract: 1

DATED: 5 August 1994

Horst BORMET

Patent Attorney for and  
on behalf of the Applicant

653580

P/00/008  
Section 29(1)  
Regulation 3.1(2)

AUSTRALIA  
Patents Act 1990

## NOTICE OF ENTITLEMENT

We Horst BORMET  
of MITTELSTR. 8  
D-6108 WEITERSTADT  
GERMANY

being the applicants in respect of an application for a patent for an invention entitled SCREENING RAKE (Application No. 11755/92), state the following:

1. The nominated person has, for the following reasons, gained entitlement from the actual inventors:

The nominated person is the assignee of Bormet Maschinenbau GmbH & Co KG who in turn would have been entitled to have assigned to it any patent granted to the inventors in respect of the said invention.

2. The nominated person has, for the following reasons, gained entitlement from the basic applicant listed on the patent request:

The nominated person is the basic applicant.

3. The basic application(s) listed on the request form is/are the first application(s) made in a Convention country in respect of the invention.

DATE: 5 August 1994

Horst BORMET

GRIFFITH HARRIS & CO.

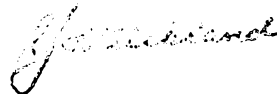

Patent Attorney for and  
on behalf of the applicant



AU9211755

(12) PATENT ABRIDGMENT (11) Document No. AU-B-11755/92  
(19) AUSTRALIAN PATENT OFFICE (10) Acceptance No. 653580

- (54) Title  
SCREENING RAKE
- International Patent Classification(s)  
(51)<sup>5</sup> B01D 033/04 E02B 005/08
- (21) Application No. : 11755/92 (22) Application Date : 29.01.92
- (87) PCT Publication Number : WO92/18221
- (30) Priority Data
- | (31) Number | (32) Date | (33) Country |
|-------------|-----------|--------------|
| 9104551     | 13.04.91  | DE GERMANY   |
- (43) Publication Date : 17.11.92
- (44) Publication Date of Accepted Application : 06.10.94
- (71) Applicant(s)  
HORST BORMET
- (72) Inventor(s)  
HORST BORMET; ERICH FINK
- (74) Attorney or Agent  
GRIFFITH HACK & CO , GPO Box 1285K, MELBOURNE VIC 3001
- (56) Prior Art Documents  
AU 79952/91 B01D 33/-
- (57) Claim

1. Sieve rake for the removal of solid matter from a waste water current, with a driven sieve belt (5) that can be positioned in the waste water, which sieve belt (5) exhibits two lateral link chains (11) between which run support rods (12, 12', 12'') which support groups of sieve members which are provided with hooks (13a) and are positioned one beside the other, wherein each group of sieve members (13, 13') is positioned on two support rods (12 or 12' or 12'') independent of the preceding and succeeding group of sieve members (13, 13').



<p>(51) Internationale Patentklassifikation <sup>5</sup> :  <b>B01D 33/04, E02B 5/08</b></p>	<p><b>A1</b></p>	<p>(11) Internationale Veröffentlichungsnummer: <b>WO 92/18221</b>                  (43) Internationales Veröffentlichungsdatum: <b>29. Oktober 1992 (29.10.92)</b></p>
--	------------------	---

(21) Internationales Aktenzeichen: PCT/EP92/00186  
 (22) Internationales Anmeldedatum: 29. Januar 1992 (29.01.92)  
 (30) Prioritätsdaten:  
 G 91 04 551.7 U 13. April 1991 (13.04.91) DE  
 (71)(72) Anmelder und Erfinder: BORMET, Horst [DE/DE];  
 Mittelstr. 8, D-6108 Weiterstadt (DE).  
 (72) Erfinder; und  
 (75) Erfinder/Anmelder (nur für US) : FINK, Erich [DE/DE];  
 Auf dem Frongrund 16, D-6110 Dieburg (DE).  
 (74) Anwalt: KATSCHER, Helmut; Bismarckstr. 29, D-6100  
 Darmstadt (DE).

(81) Bestimmungsstaaten: AT (europäisches Patent), AU, BB, BE (europäisches Patent), BF (OAPI Patent), BG, BJ (OAPI Patent), BR, CA, CF (OAPI Patent), CG (OAPI Patent), CH (europäisches Patent), CI (OAPI Patent), CM (OAPI Patent), CS, DE (europäisches Patent), DK (europäisches Patent), ES (europäisches Patent), FI, FR (europäisches Patent), GA (OAPI Patent), GB (europäisches Patent), GN (OAPI Patent), GR (europäisches Patent), HU, IT (europäisches Patent), JP, KP, KR, LK, LU (europäisches Patent), MC (europäisches Patent), MG, ML (OAPI Patent), MR (OAPI Patent), MW, NL (europäisches Patent), NO, PL, RO, RU, SD, SE (europäisches Patent), SN (OAPI Patent), TD (OAPI Patent), TG (OAPI Patent), US.

Veröffentlicht  
 Mit internationalem Recherchenbericht.

653580

(54) Title: SCREENING RAKE  
 (54) Bezeichnung: SIEBRECHEN

(57) Abstract

The invention concerns a screening rake for removing solids from flowing sewage, the rake having a driven screening belt (5) which can be immersed in the sewage and which has two lateral chains (11). A group of screening elements fitted with hooks is mounted on each of two support rods independently of the preceding and following group of screening elements. The screening elements in each group have extension pieces which project beyond the two associated support rods in the direction of travel of the screening belt and in the opposite direction. The extension pieces of successive groups of screening elements engage with each other like the teeth of a comb.

(57) Zusammenfassung

Ein Siebrechen zum Austrag von Feststoffen aus einem Abwasserstrom weist ein antreibbares, in den Abwasserstrom einsetzbares Siebband (5) auf, das zwei seitliche Gliederketten (11) hat. Jeweils eine Gruppe von mit Haken versehenen Siebgliedern ist auf zwei Tragstangen unabhängig von der vorangehenden und der nachfolgenden Gruppe von Siebgliedern angeordnet. Die Siebglieder jeder Gruppe weisen in Bandlaufrichtung und entgegengesetzt dazu über die beiden zugeordneten Tragstangen hinausragende Gliedfortsätze auf. Die Gliedfortsätze aufeinanderfolgender Gruppen von Siebgliedern greifen kammartig ineinander.

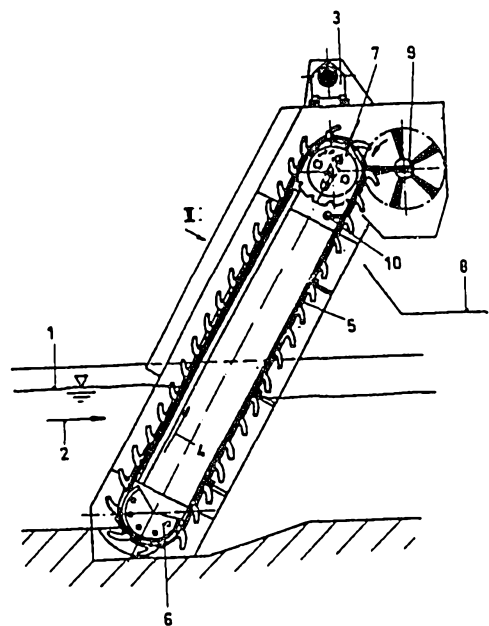

## Sieve Rake

The invention relates to a sieve rake for the removal of solid matter from a waste water current, with a driven sieve belt that can be immersed in the waste water current and that exhibits two lateral link chains, extending between which are support bars which support groups of filter members positioned in succession and provided with hooks.

Waste water must be mechanically purified of solid matter that is larger than a predetermined particle size, before being treated in clarification plants. Here the prior art is familiar with the process of conducting a waste water current through a sieve rake which retains the solid matter. Removal of the solid matter is necessary at regular intervals or continuously in order to avoid stoppage of the sieve rake.

Sieve and filter rakes that meet this end are known in various designs. The sieve rake usually exhibits a continuously



circulating drive sieve belt of the paternoster type, that consists of individual sieve members whose interstices form the sieve area through which the waste water flows.

Usually the sieve members, or at least several of the sieve members that compose the sieve belt, are furnished with hooks, tiers, or other projections which serve to capture the deposited solid matter, particularly bodies of larger size, and to remove it from the waste water current. The solid matter is disposed of at the head of the sieve belt onto a removal device. A rotating brush can be provided to remove adhesive material.

Given the very different characteristics of the solid matter that accumulates, including large and solid bodies, damage to the sieve member, particularly to the attached hooks, is unavoidable. Sieve members thus damaged must be replaced.

In sieve rakes of the indicated type known to the prior art (company publication SK Technical Bulletin 120 "AQUA-GUARD") each of the sieve members furnished with a hook is supported by two support rods. However, these sieve members are positioned in stacked fashion such that all support rods are connected to each of the two adjacent support rods by way of several sieve members jointly supported by these rods. The replacement of damaged sieve members is therefore relatively involved and demands a longer interruption in operation, since in detaching two support rods it is necessary not merely to remove the sieve members supported jointly by these support rods, but also to partially detach sieve members extending to the adjacent support rods. Thus the sieve belt can only be returned to operation after the complete replacement of the damaged sieve members.

In another sieve rake design known to the prior art (DE-A-39 10 464) all adjacent sieve members belonging to a single group are supported only by two joint support rods. The connection to



the given adjacent support rods occurs exclusively by means of connecting members that are not furnished with hooks. However, lateral link chains are not provided, so that when damaged sieve members are replaced this screening belt must also be removed from operation until all damaged screening members are replaced.

A longer interruption in operation is not normally possible for such sieve rakes, however, since solid matter accumulating on the sieve belt would constrain the belt, with the result that the current resistance would increase considerably and the waste water current would be unacceptably retarded. As a result, it is necessary either to permit the removal from operation of the sieve rake in need of repair by the parallel positioning of one or several other sieve rakes, or to remove the sieve rake from the waste water channel and replace it during the repair period by a reserve sieve rake, for example, a simple sieve rake that can be cleaned manually. All of these measures are complicated and expensive, however.

Thus the problem addressed by the invention is to elaborate a sieve rake of the initially described type in such a way that it remains functional after the failure of individual sieve members or entire groups of sieve members and after their removal, to thereby either totally eliminate interruptions in operation or at least reduce them to a very brief interval.

This problem is solved by the invention in that each group of sieve members is positioned on two support rods independent of the preceding and following group of sieve members.

This design makes it possible to completely dismantle a group of sieve members that are partly damaged, while the corresponding two support rods are either employed without sieve members or are replaced with bolts for the link chains. After this dismantling of a group of sieve members, which can be



performed in a brief period of time and without interruption in operation, the sieve belt can remain in operation. After removal of the group of sieve members the point that permits the unimpeded flow of the waste water can be traversed by running the sieve at high speed through the waste water current, so that immediately afterwards a completely functional area of the sieve belt comes into action.

According to a preferred embodiment of the inventive concept, the sieve members of each group exhibit extensions that protrude above the two corresponding support rods both in the belt's direction of motion and in the opposite direction, and the extensions of successive groups of sieve members interlock in a comb-like fashion.

This results in the distance between adjacent groups of sieve members being bridged with particularly success, without there being a functional dependence between adjacent groups of sieve members that could impede or disrupt the dismantling of individual groups.

Further advantageous embodiments of the inventive concept are the subject matter of other secondary claims.

The invention will now be described in greater detail on the basis of embodiment examples that are shown in the drawing.  
Shown are:

Fig. 1      simplified depiction of a sieve rake positioned in a waste water current, in vertical section



- Fig. 2 a partial top view of the sieve belt of the sieve rake in the direction of arrow II shown in fig. 1
- Fig. 3 a section along the line III-III in fig. 2
- Fig. 4 part of the sieve belt of the sieve rake of fig. 1, in exploded view
- Fig. 5 a top view of a single sieve member
- Fig. 6 the sieve member of fig. 5 in a side view in direction of arrow VI
- Fig. 7 a modified sieve member in a top view like that of fig. 5
- Fig. 8 view in direction of VIII of the sieve member of fig. 7

The sieve rake shown in fig. 1 serves to remove solid matter, particularly larger bodies, from a waste water current running in a waste water channel 1. The direction of flow is indicated by arrow II. The lower portion of the sieve rake protrudes into the waste water flow and runs upward and diagonally above the channel 1.

The sieve rake exhibits a continuously circulating sieve belt 5 that runs in the direction of arrow 4 and is guided by a lower deflection roller 6 and an upper deflection roller 7, which are driven by a belt drive 3.

The solid matter ejected at the head of the sieve belt 5 falls onto a conveyor apparatus 8 indicated only in simplified form in the drawing. Ejection of the solid matter is supported by a driven rotary brush 9 and, when necessary, by a spraying



apparatus 10.

As can be seen from the details of figs. 2 and 4, the sieve belt 5 exhibits two lateral link chains 11 which run over the deflector rollers 6 and 7. Extending at regular intervals between the two link chains 5 are support rods 12 which with their ends also form the bolts of the link chains 5.

Positioned on the support rods 12 and immediately beside the lateral link chains 5 are flat lateral bordering elements 13 which together form a lateral border on both longitudinal sides of the sieve belt 5.

The support rods 12 support several sieve members 13, between which separating elements are positioned. For the sake of easy identification, fig. 2 shows one of the sieve members 13 in highlighted form.

As can be seen in fig. 2, each group of several sieve members 13 provided with hooks 13a and with interposed separating members 14 is supported by two support rods 12. The adjacent group of sieve members 13, 14 in turn are independently supported by two support rods 12' provided exclusively for this purpose. The next group of sieve members 13, 14 is again supported independently by two corresponding support rods 12'. This configuration assures that each group of adjacent sieve members is supported independent of the preceding and succeeding group of sieve members 13, 14 on two separate supports 12, 12', 12'', etc.

Consequently it is always possible to completely remove a group of sieve members 13, 14 that are positioned side by side, independent of and unaffected by the adjacent sieve members, and to replace them. The damaged sieve members do not have to be replaced immediately. In the interim it is sufficient to reinsert the support rods 12 or to employ separate chain bolts



for the link chains 5.

To completely cover the intermediate space between adjacent groups of sieve members, sieve members 13 are designed so that in each group, both in the belt's direction of travel and in the opposite direction, the sieve members exhibit extensions 13b and 13c that project from the two corresponding support rods 12, 12', 12''. The extensions 13b, projecting forward in the belt's direction of travel, of one group and those extensions, projecting opposite the belt's direction of travel and provided with hooks 13a, of the adjacent group interlock in a comb-like fashion.

The sieve members 12 and 13 consist of flat material which rests on a plane that runs vertical to the support rods 12. To provide a secure mounting on the support rods 12 and to maintain the giving spacing from the adjacent sieve member, the sieve members 13 each have two mounting bushings 15 positioned on the two support rods 12; in the depicted embodiment these bushing extend to either side beyond the flat material of the sieve member 13.

In the example depicted in figs. 1 to 6, the sieve members 13 support lateral sieve ribs 16 on their middle section located between the two support rods 12 and on the member extension 13c; these ribs divide the intermediate spaces between adjacent sieve members 13, 14 in order to provide a sieve with a narrow mesh. Deviating from the depicted embodiment, the lateral sieve ribs 16 can also be provided on the front extension 13b and can be omitted on the rear extension 13c.

In the modified embodiment of the sieve members 13' shown in figs. 7 and 8, these lateral sieve ribs 16 have been omitted. This simpler design is sufficient when a larger sieve width is permissible or when the sieve width can be kept small enough by a



narrow positioning of the adjacent sieve members.



## Sieve Rake

### Patent Claims

1. Sieve rake for the removal of solid matter from a waste water current, with a driven sieve belt (5) that can be positioned in the waste water, which sieve belt (5) exhibits two lateral link chains (11) between which run support rods (12, 12', 12'') which support groups of sieve members which are provided with hooks (13a) and are positioned one beside the other, wherein each group of sieve members (13, 13') is positioned on two support rods (12 or 12' or 12'') independent of the preceding and succeeding group of sieve members (13, 13').
2. Sieve rake as defined in claim 1, wherein the sieve members (13) of each group exhibit extensions (13b, 13c) which protrude from the two corresponding support rods (12 or 12' or 12'') in the belt's direction of travel and opposite thereto, and the member extensions (13b, 13c) of successive groups of sieve members (13 or 13') intermesh in comb-like fashion.
3. Sieve rake as defined in claim 2, wherein the rear extensions (13c) that run opposite to the belt's direction of motion each support a hook (13a) that projects from the belt plane.
4. Sieve rake as defined in claim 2, wherein the sieve members (13, 13', 14) consist of flat material that rests on a plane running perpendicular to the support rods (12, 12', 12'').
5. Sieve rake as defined in claim 4, wherein the sieve members



(13, 13') each exhibit two bushings (15) mounted on the two support rods (12, 12', 12'').

6. Sieve rake as defined in claim 2, wherein the sieve members (13) exhibit lateral sieve ribs (16) on the central section lying between the support rods (12) and on at least one of the two extensions (13b or 13c).



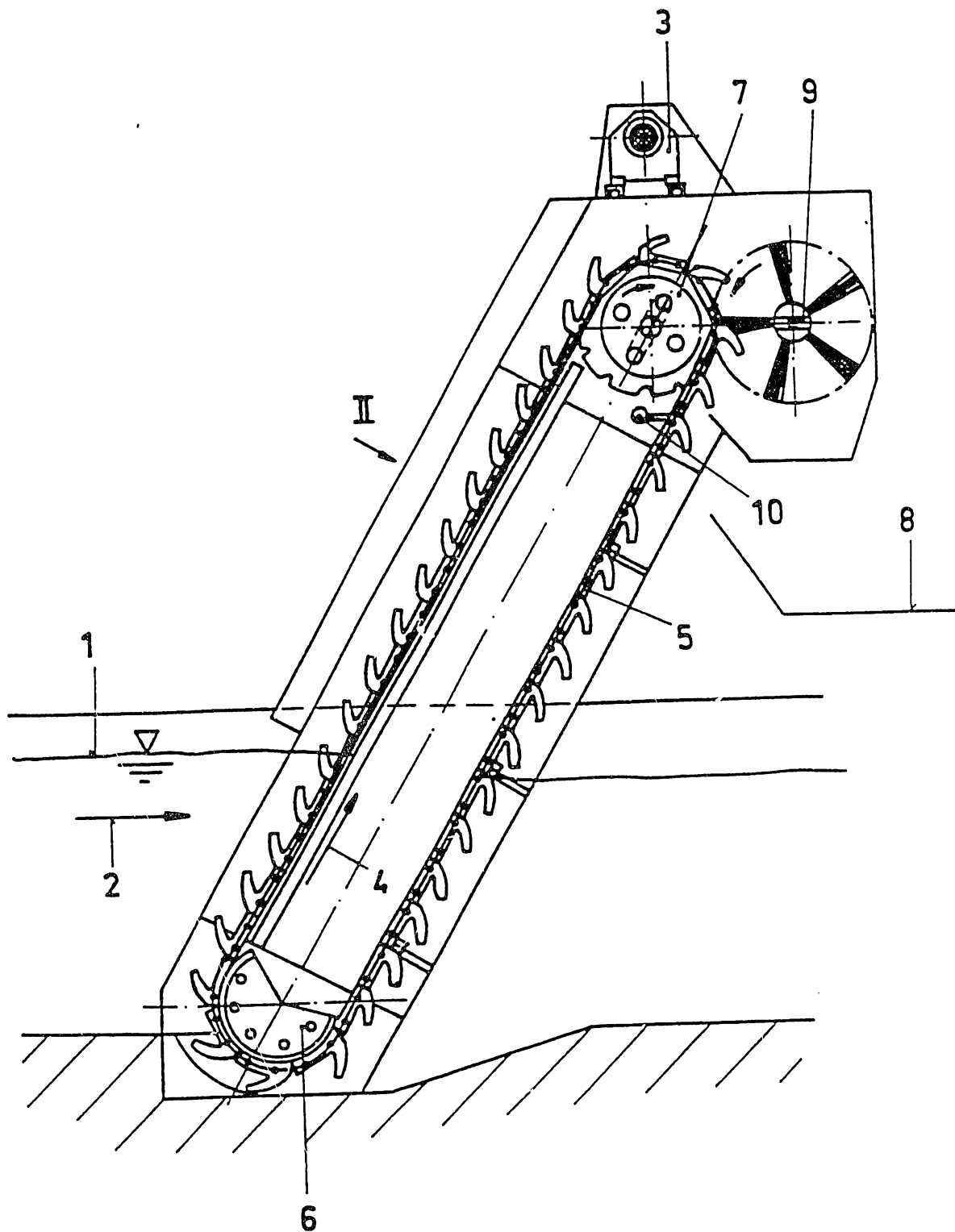

FIG. 1

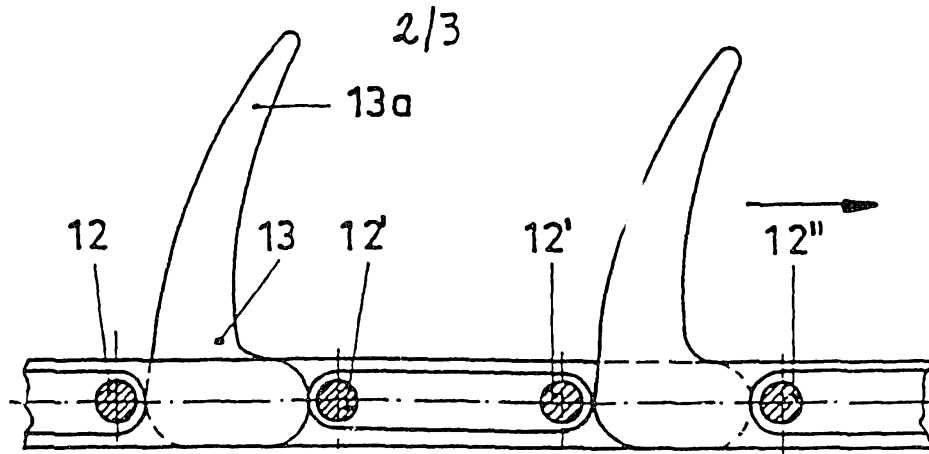

FIG. 3

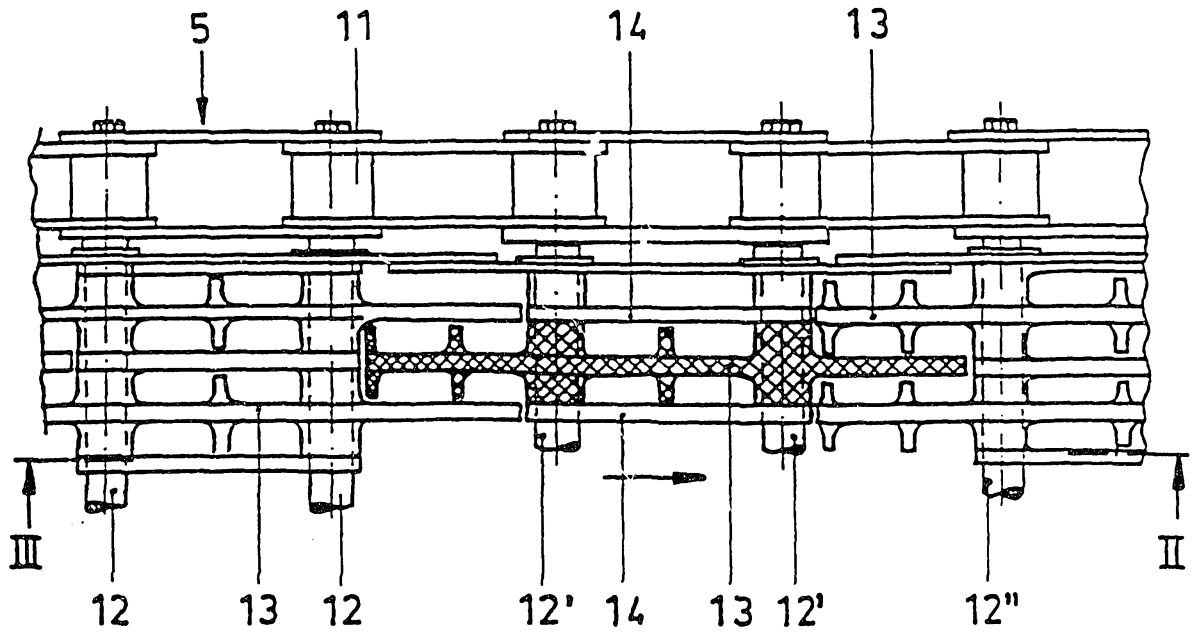

FIG. 2

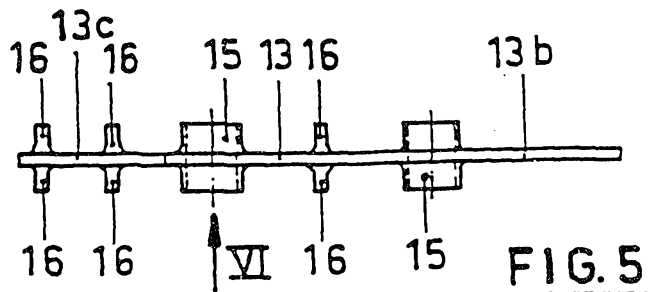

FIG. 5

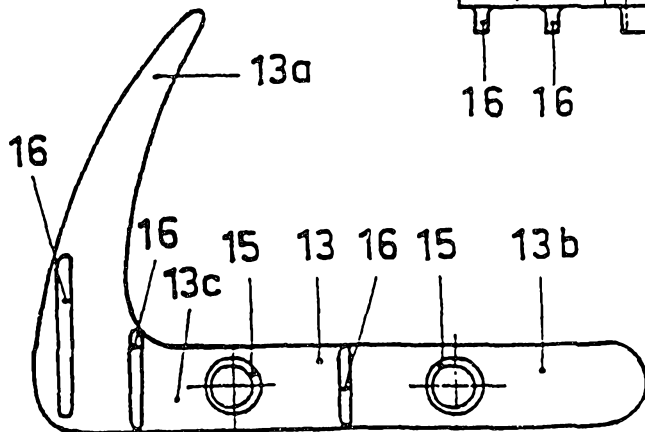

FIG. 6

3/3

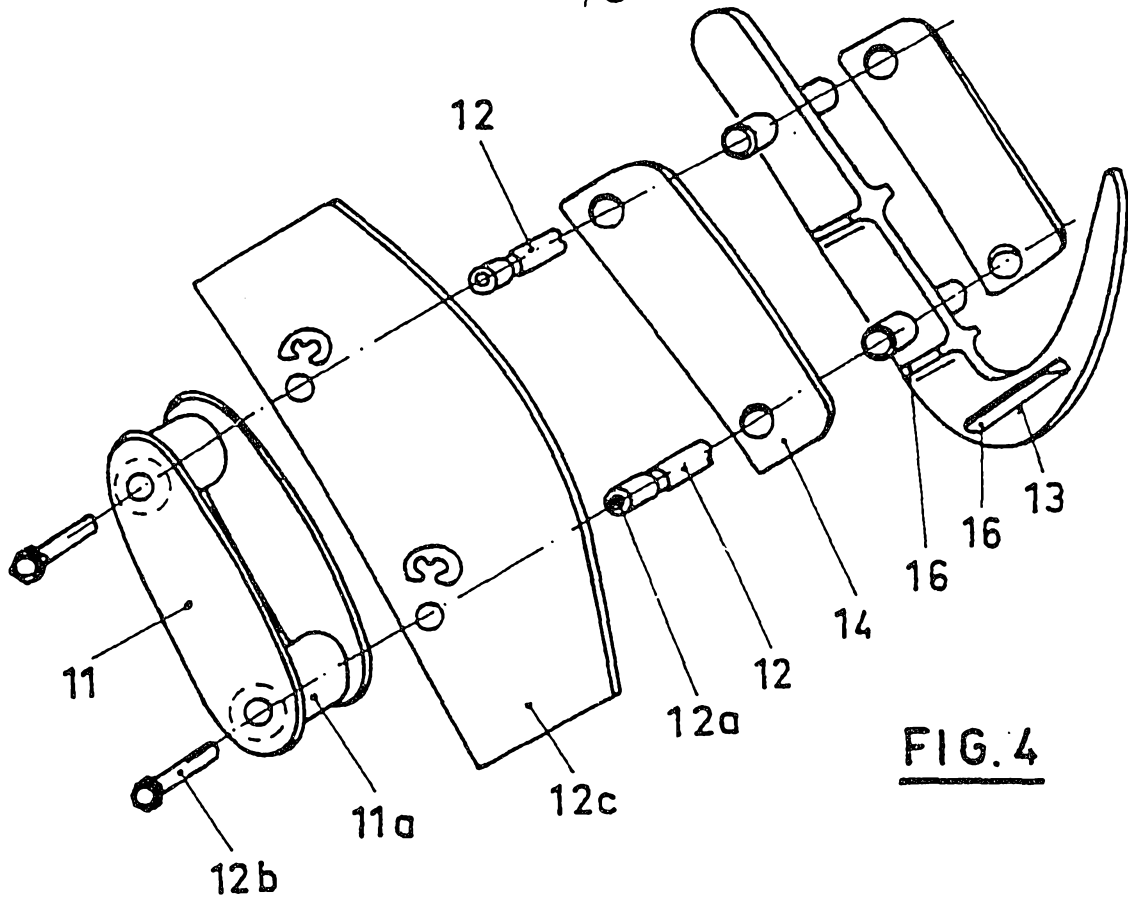

FIG. 4

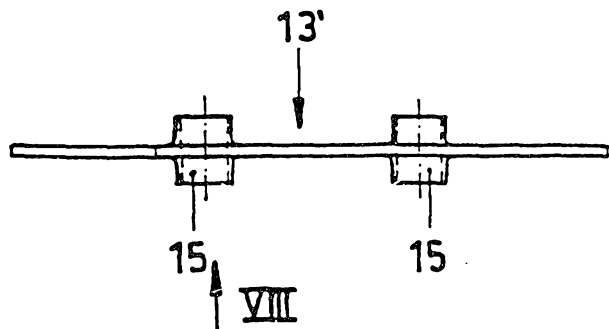

FIG. 7

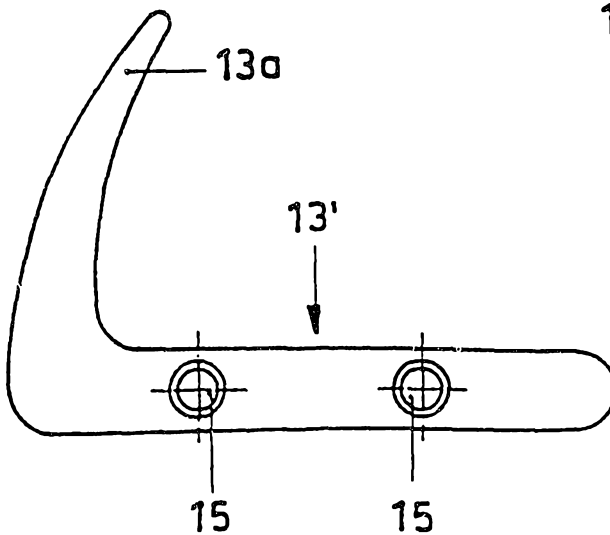

FIG. 8

## INTERNATIONAL SEARCH REPORT

International application No.

PCT/EP92/00186

## A. CLASSIFICATION OF SUBJECT MATTER

Int.Cl.:<sup>5</sup> B01D33/04; E02B 5/08

According to International Patent Classification (IPC) or to both national classification and IPC

## B. FIELDS SEARCHED

Minimum documentation searched (classification system followed by classification symbols)

Int.Cl.:<sup>5</sup> B01D ; E02B

Documentation searched other than minimum documentation to the extent that such documents are included in the fields searched

Electronic data base consulted during the international search (name of data base and, where practicable, search terms used)

## C. DOCUMENTS CONSIDERED TO BE RELEVANT

Category*	Citation of document, with indication, where appropriate, of the relevant passages	Relevant to claim No.
Y A	EP,A,0 389 816 (E + M MASCHINENBAU) 3 October 1990 see column 2 - column 7 -----	1 3,4
Y A	GB,A,2 045 634 (B.J. HOLMES) 5 November 1980 see page 3, line 47 - page 6, line 94 -----	1 4
A	DE,A,2 401 956 (HAGIHARA TADASHI) 17 July 1975 see page 5 - page 12 -----	2,3,4,6

 Further documents are listed in the continuation of Box C. See patent family annex.

## \* Special categories of cited documents:

"A" document defining the general state of the art which is not considered to be of particular relevance

"E" earlier document but published on or after the international filing date

"L" document which may throw doubts on priority claim(s) or which is cited to establish the publication date of another citation or other special reason (as specified)

document referring to an oral disclosure, use, exhibition or other means

document published prior to the international filing date but later than the priority date claimed

"T" later document published after the international filing date or priority date and not in conflict with the application but cited to understand the principle or theory underlying the invention

"X" document of particular relevance; the claimed invention cannot be considered novel or cannot be considered to involve an inventive step when the document is taken alone

"Y" document of particular relevance; the claimed invention cannot be considered to involve an inventive step when the document is combined with one or more other such documents, such combination being obvious to a person skilled in the art

"&amp;" document member of the same patent family

Date of the actual completion of the international search

06 March 1992 (06-03-92)

Date of mailing of the international search report

20 March 1992 (20-03-92)

Name and mailing address of the ISA/

EUROPEAN PATENT OFFICE

Facsimile No.

Authorized officer

Telephone No.

**ANNEX TO THE INTERNATIONAL SEARCH REPORT  
ON INTERNATIONAL PATENT APPLICATION NO. EP 9200186  
SA 55455**

This annex lists the patent family members relating to the patent documents cited in the above-mentioned international search report. The members are as contained in the European Patent Office EDP file on The European Patent Office is in no way liable for these particulars which are merely given for the purpose of information. 06/03/92

Patent document cited in search report	Publication date	Patent family member(s)	Publication date
EP-A-0389816	03-10-90	DE-A- 3910464 JP-A- 2280805 US-A- 5059313	04-10-90 16-11-90 22-10-91
GB-A-2045634	05-11-80	None	
DE-A-2401956	17-07-75	None	

EPO FORM P0079

For more details about this annex : see Official Journal of the European Patent Office, No. 12/82

## INTERNATIONALER RECHERCHENBERICHT

Internationales Aktenzeichen

PCT/EP 92/00186

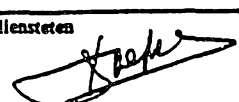
I. KLASSIFIKATION DES ANMELDUNGSGEGENSTANDS (bei mehreren Klassifikationssymbolen sind alle anzugeben) <sup>6</sup>		
Nach der Internationalen Patentklassifikation (IPC) oder nach der nationalen Klassifikation und der IPC		
Int.Kl. 5 B01D33/04; E02B5/08C		
II. RECHERCHIERTE SACHGEBIETE		
Recherchierter Mindestprüfstoff <sup>7</sup>		
Klassifikationssystem	Klassifikationssymbole	
Int.Kl. 5	B01D ; E02B	
Recherchierte nicht zum Mindestprüfstoff gehörende Veröffentlichungen, soweit diese unter die recherchierten Sachgebiete fallen <sup>8</sup>		
III. EINSCHLAGIGE VERÖFFENTLICHUNGEN <sup>9</sup>		
Art. <sup>o</sup>	Kennzeichnung der Veröffentlichung <sup>11</sup> , soweit erforderlich unter Angabe der maßgeblichen Teile <sup>12</sup>	Betr. Anspruch Nr. <sup>13</sup>
Y	EP,A,0 389 816 (E + M MASCHINENBAU) 3. Oktober 1990	1
A	siehe Spalte 2 - Spalte 7 ---	3,4
Y	GB,A,2 045 634 (B.J. HOLMES) 5. November 1980	1
A	siehe Seite 3, Zeile 47 - Seite 6, Zeile 94 ---	4
A	DE,A,2 401 956 (HAGIHARA TADASHI) 17. Juli 1975 siehe Seite 5 - Seite 12 ---	2,3,4,6
<p><sup>o</sup> Besondere Kategorien von angegebenen Veröffentlichungen<sup>10</sup> :</p> <p>"A" Veröffentlichung, die den allgemeinen Stand der Technik definiert, aber nicht als besonders bedeutsam anzusehen ist</p> <p>"E" Älteres Dokument, das jedoch erst am oder nach dem internationalen Anmeldedatum veröffentlicht worden ist</p> <p>"L" Veröffentlichung, die geeignet ist, einen Prioritätsanspruch zweifelhaft erscheinen zu lassen, oder durch die das Veröffentlichungsdatum einer anderen im Recherchenbericht genannten Veröffentlichung belegt werden soll oder die aus einem anderen besonderen Grund angegeben ist (wie ausgeführt)</p> <p>"O" Veröffentlichung, die sich auf eine mündliche Offenbarung, eine Benutzung, eine Ausstellung oder andere Maßnahmen bezieht</p> <p>"P" Veröffentlichung, die vor dem internationalen Anmeldedatum, aber nach dem beanspruchten Prioritätsdatum veröffentlicht worden ist</p> <p>"T" Spätere Veröffentlichung, die nach dem internationalen Anmeldedatum oder dem Prioritätsdatum veröffentlicht worden ist und mit der Anmeldung nicht kollidiert, sondern nur zum Verständnis des der Erfindung zugrundeliegenden Prinzips oder der ihr zugrundeliegenden Theorie angegeben ist</p> <p>"X" Veröffentlichung von besonderer Bedeutung; die beanspruchte Erfindung kann nicht als neu oder auf erfinderischer Tätigkeit beruhend betrachtet werden</p> <p>"Y" Veröffentlichung von besonderer Bedeutung; die beanspruchte Erfindung kann nicht als auf erfinderischer Tätigkeit beruhend betrachtet werden, wenn die Veröffentlichung mit einer oder mehreren anderen Veröffentlichungen dieser Kategorie in Verbindung gebracht wird und diese Verbindung für einen Fachmann naheliegend ist</p> <p>"&amp;" Veröffentlichung, die Mitglied derselben Patentfamilie ist</p>		
IV. BESCHEINIGUNG		
Datum des Abschlusses der internationalen Recherche	06. MAERZ 1992	Absenddatum des internationalen Recherchenberichts
		20. 03. 92
Internationale Recherchenbehörde	EUROPAISCHES PATENTAMT	Unterschrift des bevollmächtigten Bediensteten
		DE PAEPE P. F. J. 

**ANHANG ZUM INTERNATIONALEN RECHERCHENBERICHT  
 ÜBER DIE INTERNATIONALE PATENTANMELDUNG NR.**

EP 9200186  
 SA 55455

In diesem Anhang sind die Mitglieder der Patentfamilien der im obengenannten internationalen Recherchenbericht angeführten Patentdokumente angegeben.

Die Angaben über die Familienmitglieder entsprechen dem Stand der Datei des Europäischen Patentamts am  
 Diese Angaben dienen nur zur Unterrichtung und erfolgen ohne Gewähr.

06/03/92

Im Recherchenbericht angeführtes Patentdokument	Datum der Veröffentlichung	Mitglied(er) der Patentfamilie	Datum der Veröffentlichung
EP-A-0389816	03-10-90	DE-A- 3910464 JP-A- 2280805 US-A- 5059313	04-10-90 16-11-90 22-10-91
GB-A-2045634	05-11-80	Keine	
DE-A-2401956	17-07-75	Keine	

EPO FORM P0073

Für nähere Einzelheiten zu diesem Anhang : siehe Amtsblatt des Europäischen Patentamts, Nr.12/82