

J. Mield.
Loom.

Sheet 1-3 Sheets.

N^o 3,955.

Patented Mar. 15, 1845.

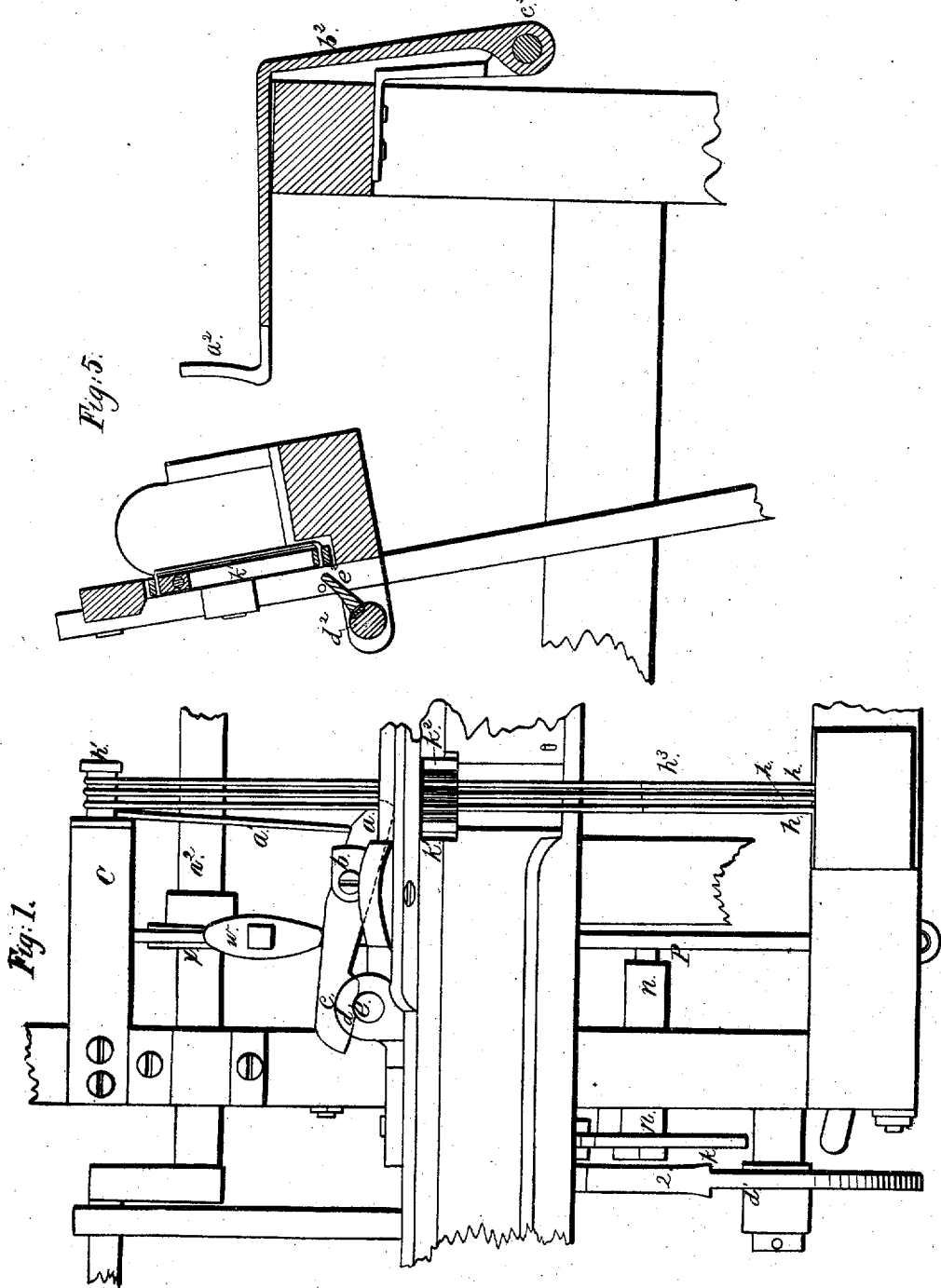

J. Mield.
Loom.

N^o 3,955.

Patented Mar. 15, 1845.

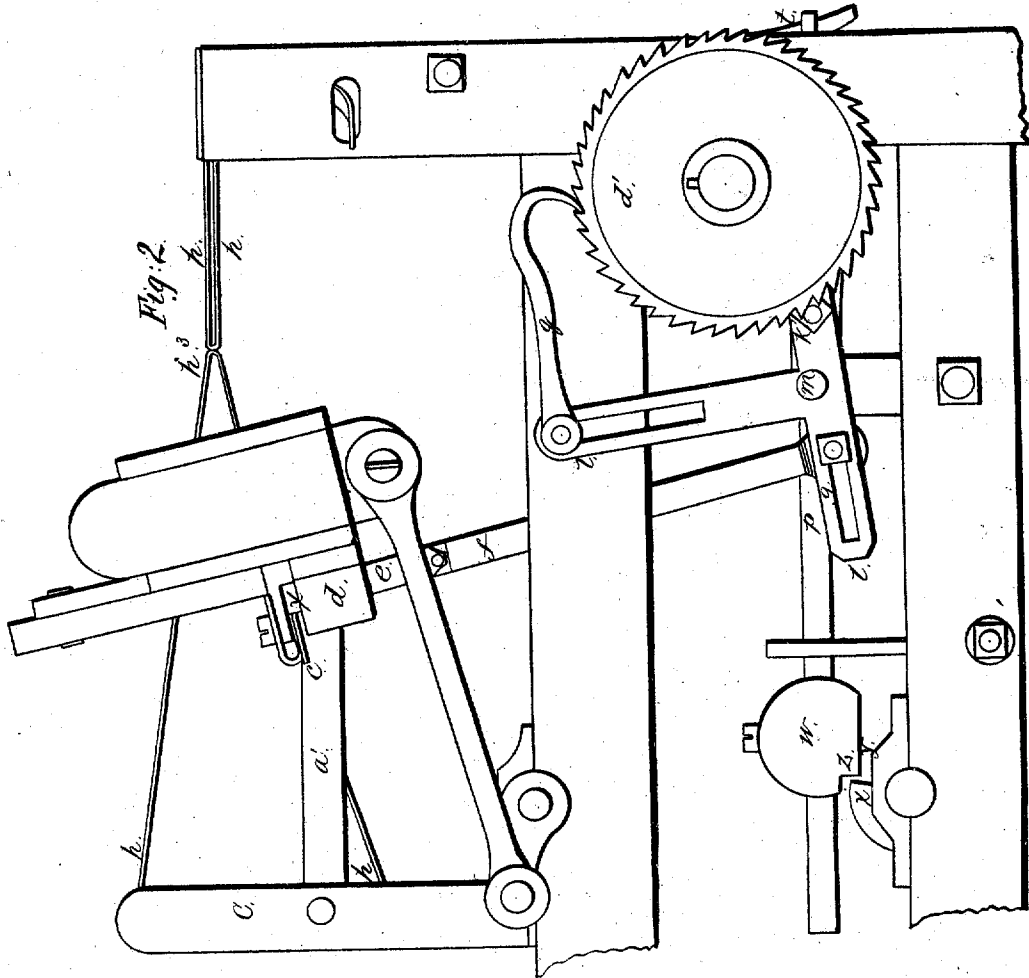

J. Nield.
Loom.

N^o 3,955.

Patented Mar. 15, 1845.

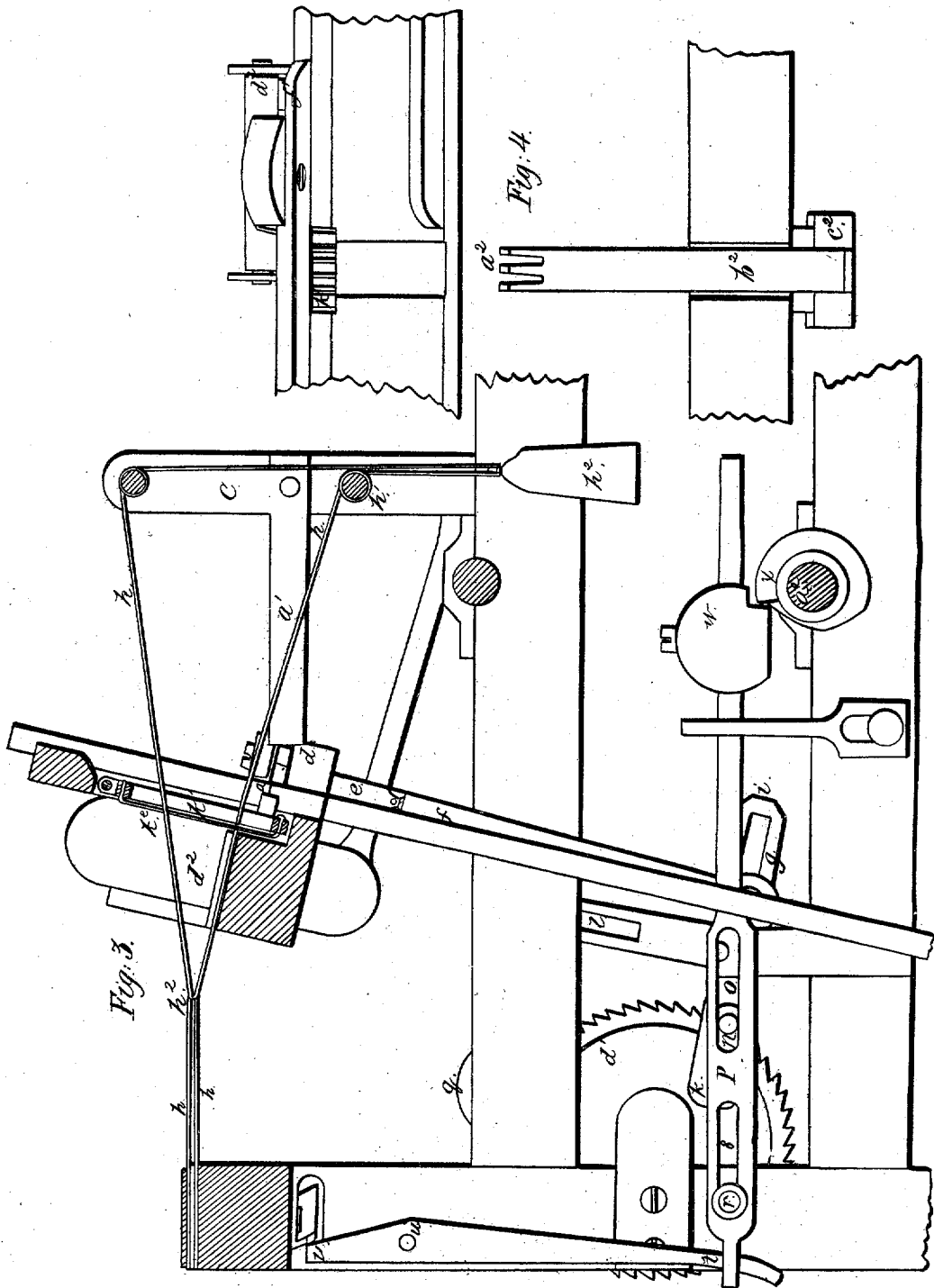

UNITED STATES PATENT OFFICE.

JAMES NIELD, OF TAUNTON, MASSACHUSETTS.

POWER-LOOM.

Specification of Letters Patent No. 3,955, dated March 15, 1845.

To all whom it may concern:

Be it known that I, JAMES NIELD, of Taunton, in the State of Massachusetts, have invented a new and useful Improvement in Looms for Weaving, and that the following description and accompanying drawings, taken in connection, constitute a full and exact specification of the construction and operation of my said invention.

Of the said drawings, Figure 1, represents a top view of one end of a loom, and Fig. 2, a side elevation of the same. Fig. 3 is a vertical section taken so as to exhibit the opposite sides of the parts as seen in the side elevation. Fig. 4 is a top view and Fig. 5, is a vertical section of a portion of the lay and breast beam exhibiting a somewhat different arrangement of certain parts to be hereinafter described.

There are six or more cords h, h , (Figs 1, 2, 3) attached to the breast beam and passing from thence through the end of the lay to, and over pulleys, h', h' , on standards, toward the back of the loom, the said cords having weights h^2, h^2 to keep them in a state of tension. The upper and lower sets of cords are connected together at h^3 , and from this point they diverge from each other until they pass over the pulleys; the object of the divergence thereof being to admit of the passage of the shuttle between them when the lay is thrown out. These cords pass between cords h^2 stretched in a frame h' so hinged at its top to the lay, (and at the end of and in continuation of the reed) so that it (the frame) will turn on its hinge on the forward movement of the lay when the filling has been carried through and left in the angular space d^2 formed by the cords h, h . A lever a, b, c , turns on a fulcrum (attached to the back of the lay) horizontally and is so arranged as to have its end, a , just back of the lower end of the frame h' , or so that, when the frame is thrown back, it shall come into contact with and move the end, a , of the lever, and thereby cause the opposite end c , to be pressed into a horizontal aperture or recess a' formed to receive it through the side of a vertical tube d attached to the back side of the lay.

A small piston e is inserted in the lower part of the tube—the said piston playing freely therein and being jointed to the upper end of a vertical rod f , whose lower end or foot is jointed or suitably and similarly con-

nected to one end g of an inverted vibrating T lever, i, k, l , turning on a fulcrum at m , Fig. 2. The end k , of the lever has an arm n projecting from it horizontally, the inner end of the arm—or that which is toward the center of the loom, is turned down smaller than the rest of the arm, and enters an elongated slot o , of a sliding lever p . The upper end l , of the T lever has a pulling pawl q , jointed to it, which (pawl) acts upon the teeth of the ratchet wheel d' on the cloth beam, or connected with it, by gear wheels in manner well known to all acquainted with power looms.

The fulcrum of the lever p is at r , Fig. 3. Another elongated hole or slot s , is formed in the lever, and through which the fulcrum passes permitting the lever to slide or move in the direction of its length whenever necessary. The rear end of the lever p is jointed to the lower end of an upright lever t, u, v , bearing against the ordinary "protection lever", which, being well known needs not to be described and represented. The other end of the lever p , has a weight w fixed upon it, which acts to depress the end of the lever. A cam x (on the shaft a^2) acting on the underside of the weight w alternately elevates and permits the lever p to descend and thus causes the pawl q to turn the ratchet wheel d' and thereby take up the cloth as woven. Now, should one of the filling threads break during the passage of the shuttle from one box to the other, there will be no thread in the space d^2 . Consequently the frame h' will not be moved outward when the lay beats up. Therefore the lever a, b, c will be stationary, or its end c will be within the tube d , and as the piston e rises, it will abut against the lever, and thereby cause the lever p to be held down, so that a projection or shoulder y of the cam will come in contact with another one or shoulder z of the weight, and move the lever p forward or longitudinally and thus stop the movement of the machine. When the lay beats back, an arm a' , projecting from the standard e , which supports the pulleys of the threads h, h , strikes the end a of the lever a, b, c , and forces it and the frame h' forward so as to throw the other end (c) of the lever out of the tube d , and thereby permit the requisite use of the piston within the tube.

In lieu of the looped strings h, h , I sometimes use a fork a^2 (Figs. 4 and 5) of three

bars bent upward vertically and so arranged upon a bent bar b^2 (turning upon a bearing e^2 at its opposite and longest end) that the prongs of the fork will pass between the vertical strings of the frame k' , the said frame being arranged like that represented in Figs. 1, 2, and 3. A horizontal shaft d^2 may be arranged so as to move in proper bearings in front of the frame k' . This shaft has a projection e^2 at one end which extends underneath the frame k' , when the latter is thrown forward, but which will rise upward when the frame does not go forward. A similar projection f' , extends from the other end of the shaft as seen in Fig. 4. The piston e of the vertical rod f , (Fig. 2) operates in connection with this last projection as it did with the lever a, b, c Fig. 1.

I claim—

The peculiar "take up motion" and machinery for arresting the progress of the

loom when a filling thread breaks as represented in the drawing; the same consisting of a series of looped strings or other similar contrivances fixed to the breast beam, and arranged in other respects as set forth, the moving or hinged frame k , and other mechanism intervening between the said frame and the usual hand lever and shaft of the ratchet wheel d' or connecting the same together; that is to say, I claim the combination of the said mechanism for the object and purposes specified; the same being substantially as set forth.

In testimony that the foregoing is a correct specification of my said invention, I have hereto set my signature this fourth day of February A. D. 1845.

JAMES NIELD.

Witnesses:

S. A. WILDING,
JOEL W. WHITE.