



(86) **Date de dépôt PCT/PCT Filing Date:** 2010/04/08
 (87) **Date publication PCT/PCT Publication Date:** 2010/10/14
 (45) **Date de délivrance/Issue Date:** 2016/12/13
 (85) **Entrée phase nationale/National Entry:** 2011/10/07
 (86) **N° demande PCT/PCT Application No.:** US 2010/030332
 (87) **N° publication PCT/PCT Publication No.:** 2010/118193
 (30) **Priorité/Priority:** 2009/04/10 (US12/421,928)

(51) **Cl.Int./Int.Cl. A61L 27/04** (2006.01),
A61L 31/02 (2006.01)
 (72) **Inventeur/Inventor:**
WEBER, JAN, NL
 (73) **Propriétaire/Owner:**
BOSTON SCIENTIFIC SCIMED, INC., US
 (74) **Agent:** SMART & BIGGAR

(54) **Titre : DISPOSITIFS MEDICAUX IMPLANTABLES BIOERODABLES INTEGRANT DES ALLIAGES DE MAGNESIUM
SURSATURES**

(54) **Title: BIOERODIBLE, IMPLANTABLE MEDICAL DEVICES INCORPORATING SUPERSATURATED MAGNESIUM ALLOYS**

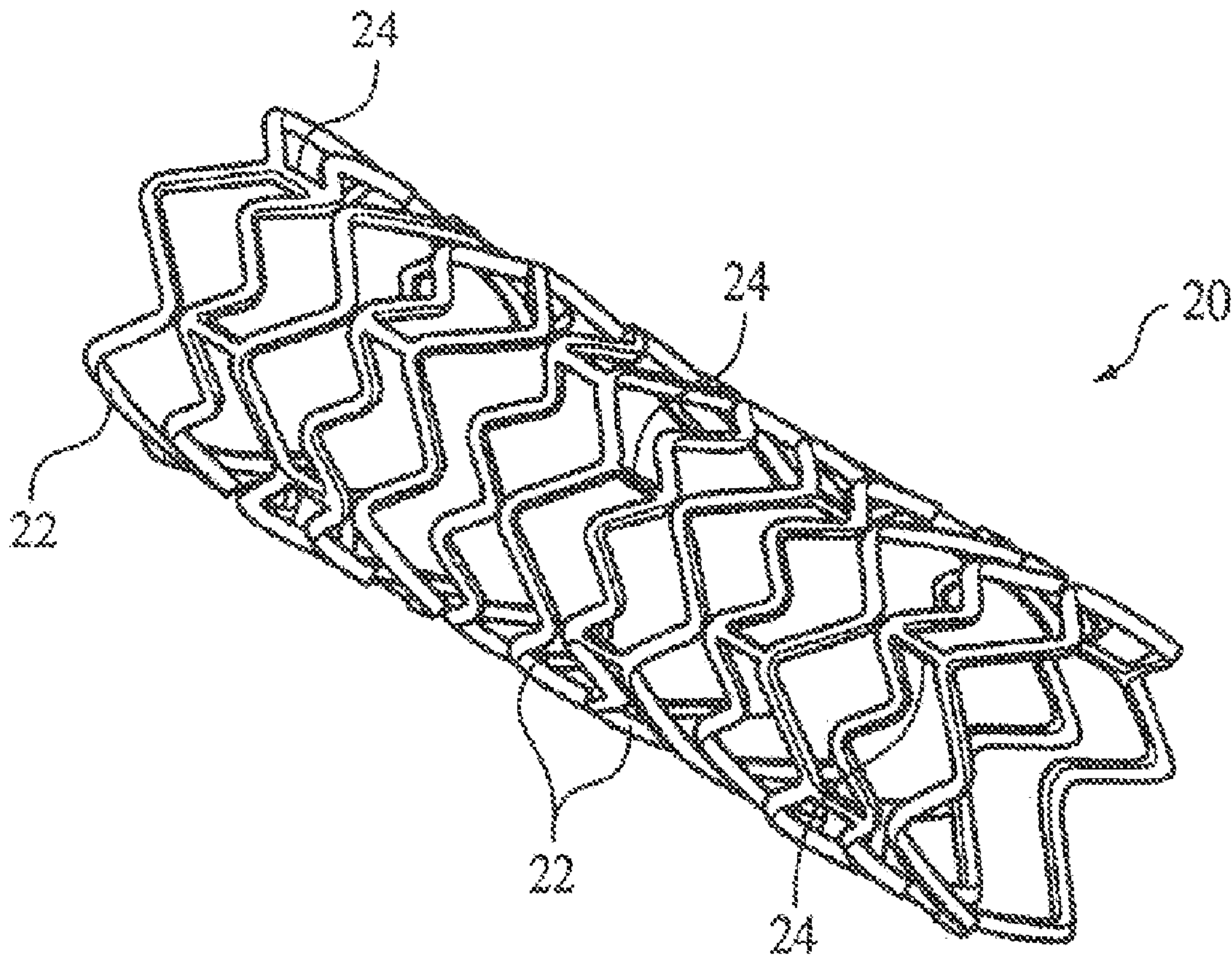

(57) **Abrégé/Abstract:**

A bioerodible, implantable medical device that includes a supersaturated magnesium alloy. The magnesium alloy includes magnesium and at least one alloying element present in a concentration in excess of the equilibrium solid solubility concentration of the alloying element in hexagonal close-packed magnesium [at 25°C].



(12) INTERNATIONAL APPLICATION PUBLISHED UNDER THE PATENT COOPERATION TREATY (PCT)

(19) World Intellectual Property Organization
International Bureau(43) International Publication Date
14 October 2010 (14.10.2010)(10) International Publication Number
WO 2010/118193 A3

(51) International Patent Classification:

A61L 27/04 (2006.01) A61L 31/02 (2006.01)

(21) International Application Number:

PCT/US2010/030332

(22) International Filing Date:

8 April 2010 (08.04.2010)

(25) Filing Language:

English

(26) Publication Language:

English

(30) Priority Data:

12/421,928 10 April 2009 (10.04.2009) US

(71) Applicant (for all designated States except US):
BOSTON SCIENTIFIC SCIMED, INC. [US/US]; One
Scimed Place, Maple Grove, Minnesota 55311-1566
(US).

(72) Inventor; and

(75) Inventor/Applicant (for US only): **WEBER, Jan**
[NL/NL]; Holdaal 49, NL-6228 GJ Maastricht (NL).(74) Agent: **WHELAN, Dorothy P.**; Fish & Richardson P.C.,
P.O. Box 1022, Minneapolis, Minnesota 55440-1022
(US).(81) Designated States (unless otherwise indicated, for every
kind of national protection available): AE, AG, AL, AM,
AO, AT, AU, AZ, BA, BB, BG, BH, BR, BW, BY, BZ,
CA, CH, CL, CN, CO, CR, CU, CZ, DE, DK, DM, DO,
DZ, EC, EE, EG, ES, FI, GB, GD, GE, GH, GM, GT,
HN, HR, HU, ID, IL, IN, IS, JP, KE, KG, KM, KN, KP,
KR, KZ, LA, LC, LK, LR, LS, LT, LU, LY, MA, MD,
ME, MG, MK, MN, MW, MX, MY, MZ, NA, NG, NI,
NO, NZ, OM, PE, PG, PH, PL, PT, RO, RS, RU, SC, SD,
SE, SG, SK, SL, SM, ST, SV, SY, TH, TJ, TM, TN, TR,
TT, TZ, UA, UG, US, UZ, VC, VN, ZA, ZM, ZW.(84) Designated States (unless otherwise indicated, for every
kind of regional protection available): ARIPO (BW, GH,
GM, KE, LR, LS, MW, MZ, NA, SD, SL, SZ, TZ, UG,
ZM, ZW), Eurasian (AM, AZ, BY, KG, KZ, MD, RU, TJ,
TM), European (AT, BE, BG, CH, CY, CZ, DE, DK, EE,
ES, FI, FR, GB, GR, HR, HU, IE, IS, IT, LT, LU, LV,
MC, MK, MT, NL, NO, PL, PT, RO, SE, SI, SK, SM,
TR), OAPI (BF, BJ, CF, CG, CI, CM, GA, GN, GQ, GW,
ML, MR, NE, SN, TD, TG).

Declarations under Rule 4.17:

— as to applicant's entitlement to apply for and be granted
a patent (Rule 4.17(ii))

[Continued on next page]

(54) Title: BIOERODIBLE, IMPLANTABLE MEDICAL DEVICES INCORPORATING SUPERSATURATED MAGNESIUM
ALLOYS

FIG. 1

(57) Abstract: A bioerodible, im-
plantable medical device that includes a
supersaturated magnesium alloy. The
magnesium alloy includes magnesium
and at least one alloying element present
in a concentration in excess of the equi-
librium solid solubility concentration of
the alloying element in hexagonal close-
packed magnesium [at 25°C].

WO 2010/118193 A3 

Published:

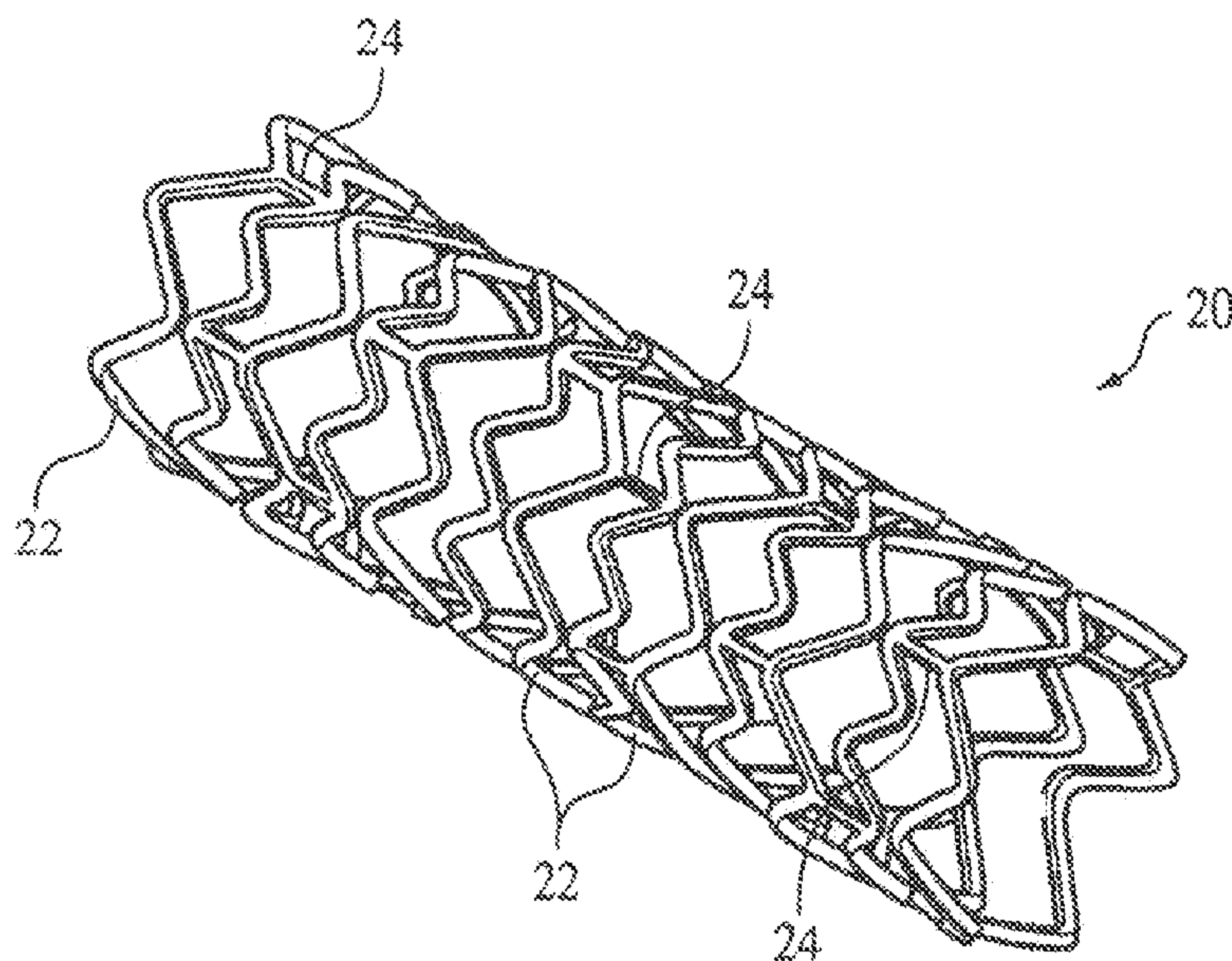
(88) Date of publication of the international search report:
31 March 2011

- *with international search report (Art. 21(3))*
- *before the expiration of the time limit for amending the claims and to be republished in the event of receipt of amendments (Rule 48.2(h))*

55527-6

BIOERODIBLE, IMPLANTABLE MEDICAL DEVICES
INCORPORATING SUPERSATURATED MAGNESIUM
ALLOYS

5

TECHNICAL FIELD

This disclosure relates to bio-erodible, implantable medical devices.

BACKGROUND

10 The body includes various passageways such as arteries, other blood vessels, and
other body lumens. These passageways sometimes become occluded or weakened. For
example, the passageways can be occluded by a tumor, restricted by plaque, or weakened
by an aneurysm. When this occurs, the passageway can be reopened or reinforced, or
even replaced, with an implantable medical device such as an endoprosthesis. An
15 endoprosthesis is typically a tubular member that is placed in a lumen in the body.
Examples of endoprostheses include stents, covered stents, and stent-grafts.

 Endoprostheses can be delivered inside the body by a catheter that supports the
endoprosthesis in a compacted or reduced-size form as the endoprosthesis is transported
to a desired site. Upon reaching the site, the endoprosthesis is expanded, for example, so
20 that it can contact the walls of the lumen.

 The expansion mechanism can include forcing the endoprosthesis to expand
radially. For example, the expansion mechanism can include the catheter carrying a
balloon, which carries a balloon-expandable endoprosthesis. The balloon can be inflated
to deform and to fix the expanded endoprosthesis at a predetermined position in contact
25 with the lumen wall. The balloon can then be deflated, and the catheter withdrawn.

 In another delivery technique, the endoprosthesis is formed of an elastic material
that can be reversibly compacted and expanded, e.g., elastically or through a material
phase transition. During introduction into the body, the endoprosthesis is restrained in a
compacted condition. Upon reaching the desired implantation site, the restraint is

removed, for example, by retracting a restraining device such as an outer sheath, enabling the endoprosthesis to self-expand by its own internal elastic restoring force.

It is sometimes desirable for an implanted medical device such as an endoprosthesis to erode over time within the passageway. For example, a fully erodible endoprosthesis does not remain as a permanent object in the body, which may help the passageway recover to its natural condition. Bio-erodible medical devices can be formed from, e.g., a polymeric material, such as polylactic acid, or from a metallic material, such as magnesium, iron, or an alloy thereof.

It may be desirable for an implanted medical device such as a stent to erode relatively slowly at first, and then to accelerate after a period of time. When used for implantable medical devices, however, magnesium alloys generally erode too quickly.

SUMMARY

A bio-erodible, implantable medical device that includes a supersaturated magnesium alloy is described. The supersaturated magnesium alloy includes magnesium and at least one alloying element present in a concentration in excess of the equilibrium solid solubility concentration of the alloying element in hexagonal close-packed magnesium at 25°C. In some embodiments, the supersaturated magnesium alloy may have an average grain size less than 10 μm , and/or include no more than 0.0015 wt% iron, no more than 0.001 wt% nickel, and no more than 0.001 wt% Cu. In some embodiments, the supersaturated magnesium alloy includes more than one alloying element.

One class of suitable alloying elements includes rare earth elements from the lanthanide series. Specific examples include lanthanum, cerium, dysprosium, gadolinium, and combinations thereof. A second class of suitable alloying elements includes refractory metals selected from the group consisting of tungsten, molybdenum, niobium, tantalum, rhenium, and combinations thereof. A third class of suitable alloying elements includes transition metals selected from the group consisting of zirconium, chromium, hafnium, and combinations thereof. A fourth class of suitable alloying elements includes calcium.

In some embodiments, the implantable medical device includes a structural member, and the supersaturated magnesium alloy forms at least a portion of the structural member. In other embodiments, the supersaturated magnesium alloy is provided in the form of a coating on a surface of the structural member. It is also possible for the
5 supersaturated magnesium alloy to form at least a portion of the structural member and to be provided as a coating on a surface of the structural member.

The bioerodible, implantable medical device may be in the form of an endoprosthesis such as a stent, an orthopedic implant, or a surgical staple.

The details of one or more embodiments are set forth in the accompanying
10 drawings and the description below. Other features, objects, and advantages will be apparent from the description and drawings, and from the claims.

DESCRIPTION OF DRAWINGS

FIG. 1 illustrates an exemplary stent.

DETAILED DESCRIPTION

15 FIG. 1 illustrates an implantable bio-erodible medical device in the form of a stent
20. A medical device is bio-erodible if the medical device, or a portion thereof, exhibits substantial mass or density reduction, or chemical transformation, after it is implanted in a patient. Mass reduction can occur by, e.g., dissolution of the material that forms the medical device and/or fragmenting of the medical device. Chemical transformation can
20 include oxidation/reduction, hydrolysis, substitution, and/or addition reactions, or other chemical reactions of the material from which the medical device, or a portion thereof, is made. The erosion can be the result of a chemical and/or biological interaction of the medical device with the body environment, e.g., the body itself or body fluids, into which it is implanted. The erosion can also be triggered by applying a triggering influence, such
25 as a chemical reactant or energy to the medical device, e.g., to increase a reaction rate.

Stent 20 includes a tubular member defined by a plurality of bands 22 and a plurality of connectors 24 that extend between and connect adjacent bands 22. During use, bands 22 can expand from an initial, small diameter, compressed state to a larger diameter to contact stent 20 against a wall of a vessel, thereby maintaining the patency of

55527-6

the vessel. Connectors 24 provide stent 20 with flexibility and conformability that allow the stent to adapt to the contours of the vessel.

In order to render stent 20 bio-erodible upon implantation, all or portions of bands 22 and/or connectors 24 can be made of a supersaturated magnesium alloy. The
5 supersaturated magnesium alloy includes magnesium and at least one alloying element present in a concentration in excess of the equilibrium solid solubility concentration of the alloying element in hexagonal close-packed magnesium at 25°C. Exemplary
supersaturated magnesium alloys, and methods for producing them, are described in U.S. Patent No. 6,908,516 to Hehmann et al. The alloying element maybe present in an
10 amount no greater than about 5wt.% based on the total weight of the alloy.

Supersaturated magnesium alloys generally exhibit small average grain size (e.g., less than 10 μm) and a substantially homogeneous distribution of the alloying element(s) throughout the body of the alloy. This, in turn, can minimize creation of microgalvanic cells that enhance erosion rates. The supersaturated magnesium alloys offer the
15 advantage, in the context of an implantable medical device such as a stent, of controlling the erosion behavior of the device so that it mimics a desired erosion profile. For example, in the case of a stent, use of the supersaturated magnesium alloy could achieve an erosion profile in which the stent erodes relatively slowly for a given period of time (e.g., for a time sufficient to allow endothelialization to take place), and then accelerates
20 at the conclusion of this period.

The supersaturated magnesium alloy preferably has a very low impurity content. For example, the supersaturated magnesium alloy can have no more than 0.0015 wt% of iron (Fe), no more than 0.001 wt% of nickel (Ni), and no more than 0.001 wt% of copper (Cu). Minimizing the amounts of these elements can minimize the formation of
25 microgalvanic couples that lead to enhanced erosion rates. For example, the erosion rate of a commercially available AZ91 magnesium alloy having about 0.005 wt% Fe is about 10 times higher than an ultra high pure AZ91 magnesium alloy having only about 0.0015 wt% Fe.

The supersaturated magnesium alloy can be obtained by rapid solidification
30 processes. The rapid solidification processes establish a homogeneous distribution of an alloying element on an atomic length scale that goes well beyond the solubility limit of

ingot metallurgy, thereby creating a supersaturation of the alloying element in the magnesium matrix. Representative examples of suitable rapid solidification processes include melt spinning, planar flow casting, and laser beam surface melting. Other examples include vapor phase processes such as vapor deposition, plasma sputtering, and magnetron sputtering. Further examples include pulsed laser deposition and nanocluster deposition. Specific examples are described in the aforementioned U.S. Patent No. 6,908,516 to Hehmann et al.

One class of suitable alloying elements for preparing the supersaturated magnesium alloy includes rare earth elements from the lanthanide series. Specific examples include lanthanum, cerium, dysprosium, gadolinium, and combinations thereof. A second class of suitable alloying elements includes refractory metals selected from the group consisting of tungsten, molybdenum, niobium, tantalum, rhenium, and combinations thereof. A third class of suitable alloying elements includes transition metals selected from the group consisting of zirconium, chromium, hafnium, and combinations thereof. A fourth class of suitable alloying elements includes calcium. Specific examples, and amounts thereof, are described in the aforementioned U.S. Patent No. 6,908,516 to Hehmann et al.

The supersaturated magnesium alloy may form all or a portion of a structural member of stent 20. The supersaturated magnesium alloy may be processed (e.g., by extrusion, rolling, forging, drawing, laser cutting, or other mechanical working) into various configurations, shapes, and/or dimensions. Regardless of the particular technique, however, the processing conditions are selected to maintain the supersaturated, non-equilibrium condition of the material. This includes avoiding the use of high temperatures that could cause the material to revert to its equilibrium condition. For example, the supersaturated magnesium alloy can be processed at temperatures lower than 140°C for time periods shorter than 1 hour. The supersaturated magnesium alloy can also be processed to form a stent using a low temperature, femtosecond laser cutting process. Chemical etching could also be used.

The supersaturated magnesium alloy may also be in the form a coating over all or a portion of an external surface of a structural member of stent 20. For example, a rapid solidification process such as vapor sputtering may be used to apply a surface coating of

a supersaturated magnesium alloy on top of a finished stent made out of a bio-erodible or non-bioerodible material. In some embodiments, a layer of a vapor deposited Mg-4.7% La alloy having a thickness of about 10 nm to about 1000 nm may be formed over a finished stent. Given a corrosion rate of about 1 $\mu\text{m}/\text{yr}$ for the supersaturated Mg-4.7wt% La alloy, a 200 nm surface layer may delay the corrosion of the underlying bulk by about 2 months. In some embodiments, a layer of a supersaturated Mg/La alloy having a thickness of about 100nm to about 1 μm may be coated partly or entirely on a finished stent that includes an AZL alloy. The AZL alloy can be prepared by adding different amounts of pure lanthanum to an AZ91D alloy. The AZL alloy can include about 6-9 wt% of Al, about 0.5-0.8 wt% of Zn, about 0.5-1.5 wt% of La, and the balance as Mg. A high purity AZL alloy can include less than about 0.002 wt% of iron, less than about 0.002 wt% of copper, and less than about 0.002 wt% of nickel. In some embodiments, the AZL alloy has about 8.99 wt% of Al, about 0.709 wt% of Zn, about 1.064 wt% of La and the balance as Mg. Compared to the base AZ91D alloy, this AZL alloy exhibits an increase of about 21.1% in the ultimate tensile strength and an increase of about 101.2% in the elongation at break. Compared to other AZL alloys, this AZL alloy with about 1 wt% of La has the highest "pitting" potential and corrosion potential and the lowest corrosion current, and thus has the least tendency to localized corrosion.

Stent 20 may include a non-bioerodible material. Representative examples of suitable non-bioerodible materials include stainless steels, platinum enhanced stainless steels, cobalt-chromium alloys, nickel-titanium alloys, and combinations thereof. In some embodiments, stent 20 may include both bio-erodible and non-bio-erodible portions. For example, stent 20 could include a structural member having a non-bio-erodible metal body and a bio-erodible supersaturated magnesium alloy coating on a surface of the metal body.

Stent 20 may include a coating to provide a desired function. For example stent 20 may include a tie layer, a biocompatible outer coating, a radiopaque metal or alloy, a drug-eluting layer, or a combination thereof.

Stent 20 may include at least one releasable therapeutic agent, drug, or pharmaceutically active compound to inhibit restenosis, such as Paclitaxel and Everolimus, or to treat and/or inhibit pain, encrustation of the stent or sclerosing or

55527-6

necrosis of a treated lumen. The therapeutic agent, drug, or pharmaceutically active compound can be a genetic therapeutic agent, a non-genetic therapeutic agent, or cells. The therapeutic agent, drug, or pharmaceutically active compound can also be nonionic, or anionic and/or cationic in nature. Representative examples of suitable therapeutic agents, drugs, or pharmaceutically active compounds include anti-thrombogenic agents, antioxidants, anti-inflammatory agents, anesthetic agents, anti-coagulants, and antibiotics. In some embodiments, the therapeutic agent, drug, or a pharmaceutically active compound may be dispersed in a polymeric coating carried by the stent. In other embodiments, the therapeutic agent, drug, or a pharmaceutically active compound may be directly incorporated into the pores on the stent surface.

Stent 20 may have any desired shape and size (e.g., superficial femoral artery stents, coronary stents, aortic stents, peripheral vascular stents, gastrointestinal stents, urology stents, and neurology stents). Depending on the application, stent 20 can have an expanded diameter of about 1 mm to about 46 mm. For example, a coronary stent can have an expanded diameter of about 2 mm to about 6 mm. A peripheral stent can have an expanded diameter of about 5 mm to about 24 mm. A gastrointestinal and/or urology stent can have an expanded diameter of about 6 mm to about 30 mm. A neurology stent can have an expanded diameter of about 1 mm to about 12 mm. An abdominal aortic aneurysm stent and a thoracic aortic aneurysm stent can have an expanded diameter of about 20 mm to about 46 mm.

Stent 20 may be self-expandable, balloon-expandable, or a combination of self-expandable and balloon-expandable (e.g., as described in U.S. Patent No. 5,366,504).

Stent 20 may have any suitable transverse cross-section, including circular and non-circular (e.g., polygonal such as square, hexagonal or octagonal).

Stent 20 can be implanted into a patient using a catheter delivery system. Representative catheter delivery systems are described in, for example, Wang, U.S. Patent No. 5,195,969; Hamlin, U.S. Patent No. 5,270,086; and Raeder-Devens, U.S. Patent No. 6,726,712. Commercial examples of stents and stent delivery systems include Radius®, Symbiot® or Sentinel® system, available from Boston Scientific Scimed, Maple Grove, MN.

55527-6

Stents 20 may be a part of a covered stent or a stent-graft. For example, stent 20 can include and/or be attached to a biocompatible, non-porous or semi-porous polymer matrix made of polytetrafluoroethylene (PTFE), expanded PTFE, polyethylene, urethane, or polypropylene.

5 Stent 20 may be configured for vascular lumens. Stent 20 may also be configured for non-vascular lumens. For example, it can be configured for use in the esophagus or the prostate. Other lumens include biliary lumens, hepatic lumens, pancreatic lumens, urethral lumens and ureteral lumens.

10 In some embodiments, stent 20 may be formed by fabricating a wire that is covered with a supersaturated Mg/La coating and then knitting and/or weaving the wire into a tubular member.

A number of embodiments of the invention have been described. Nevertheless, it will be understood that various modifications may be made without departing from the spirit and scope of the invention. For example, In addition to stents, the supersaturated
15 magnesium alloys may be used in implantable medical devices such as cochlear implants, bond screws, orthopedic implants, surgical staples, aneurism coils, and vascular closing device. Accordingly, other embodiments are within the scope of the following claims.

In the description and claims, the terms “including” and “comprising” and the like may be used interchangeably, and are open-ended or inclusive terms and do not exclude additional, unrecited items or method steps.

55527-6

CLAIMS:

1. A bio-erodible, implantable medical device comprising a supersaturated magnesium alloy that comprises magnesium and at least one alloying element present in a concentration in excess of the equilibrium solid solubility concentration of the alloying
5 element in hexagonal close-packed magnesium at 25°C.
2. A bio-erodible, implantable medical device according to claim 1 wherein the supersaturated magnesium alloy has a microstructure characterized by an average grain size less than 10 μm .
3. A bio-erodible, implantable medical device according to claim 1 wherein the
10 supersaturated magnesium alloy comprises no more than 0.0015 wt.% iron, no more than 0.001 wt.% nickel, and no more than 0.001 wt.% Cu.
4. A bio-erodible, implantable medical device according to claim 1 wherein the alloying element is a rare earth element from the lanthanide series.
5. A bio-erodible, implantable medical device according to claim 4 wherein the
15 rare earth element is selected from the group consisting of lanthanum, cerium, dysprosium, gadolinium, and combinations thereof.
6. A bio-erodible, implantable medical device according to claim 1 wherein the alloying element is a refractory metal selected from the group consisting of tungsten, molybdenum, niobium, tantalum, rhenium, and combinations thereof.
- 20 7. A bio-erodible, implantable medical device according to claim 1 wherein the alloying element is a transition metal selected from the group consisting of zirconium, chromium, hafnium, and combinations thereof.
8. A bio-erodible, implantable medical device according to claim 1 wherein the alloying element is calcium.

55527-6

9. A bio-erodible, implantable medical device according to claim 1 wherein the supersaturated magnesium alloy includes more than one alloying element.
10. A bio-erodible, implantable medical device according to claim 1 wherein the device comprises a structural member and the supersaturated magnesium alloy forms at least a
5 portion of the structural member.
11. A bio-erodible, implantable medical device according to claim 1 wherein the device comprises a structural member and the supersaturated magnesium alloy is in the form of a coating on a surface of the structural member.
12. A bio-erodible, implantable medical device according to claim 11 wherein the
10 structural member comprises a high purity AZL alloy, and wherein the coating has an average thickness of about 100 nm to about 1 μm .
13. A bio-erodible, implantable medical device according to claim 1 wherein the alloying element is present in an amount no greater than about 5 wt.% based upon the total weight of the alloy.
- 15 14. A bio-erodible, implantable medical device according to any one of claims 1 to 13 wherein the device comprises an endoprosthesis.
15. A bio-erodible, implantable medical device according to claim 14 wherein the endoprosthesis comprises a stent.
16. A bio-erodible, implantable medical device according to any one of claims 1
20 to 13 wherein the device comprises an orthopedic implant.
17. A bio-erodible, implantable medical device according to any one of claims 1 to 13 wherein the device comprises a surgical staple.
18. A bio-erodible stent comprising a supersaturated magnesium alloy that comprises magnesium and at least one alloying element present in a concentration in excess of
25 the equilibrium solid solubility concentration of the alloying element in hexagonal close-

55527-6

packed magnesium at 25°C, wherein the supersaturated magnesium alloy has a microstructure characterized by an average grain size less than 10 μm, and comprises no more than 0.0015 wt.% iron, no more than 0.001 wt.% nickel, and no more than 0.001 wt.% Cu.

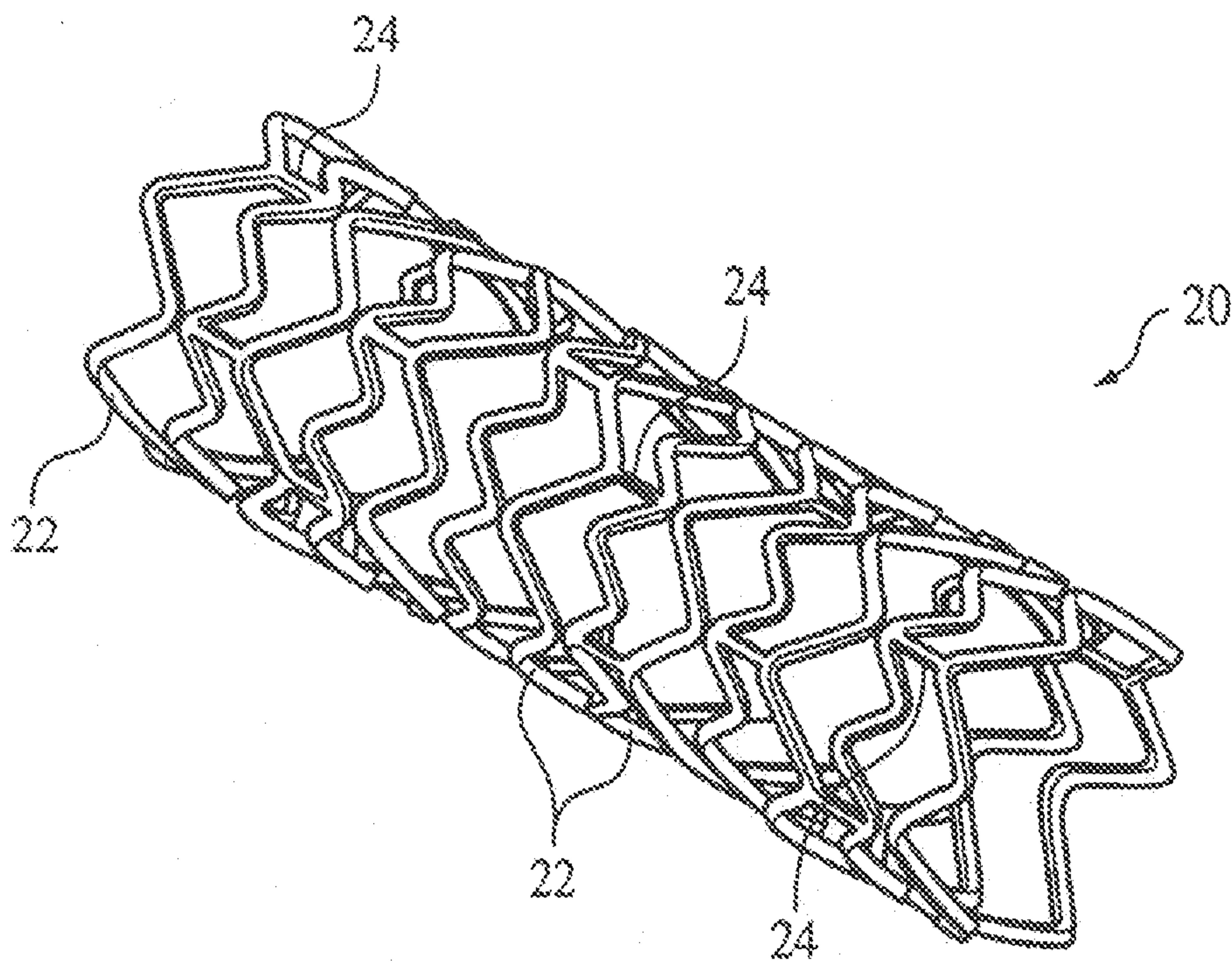

FIG. 1

