

*J. Mitchell,
Wind Wheel.*

N^o 17,384.

Patented May 26, 1857.

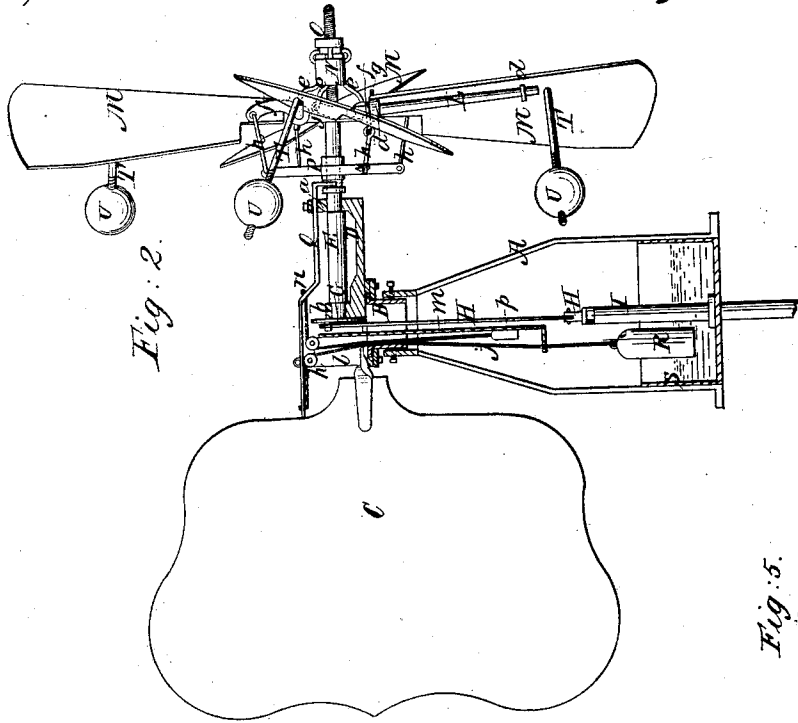

Fig. 2.

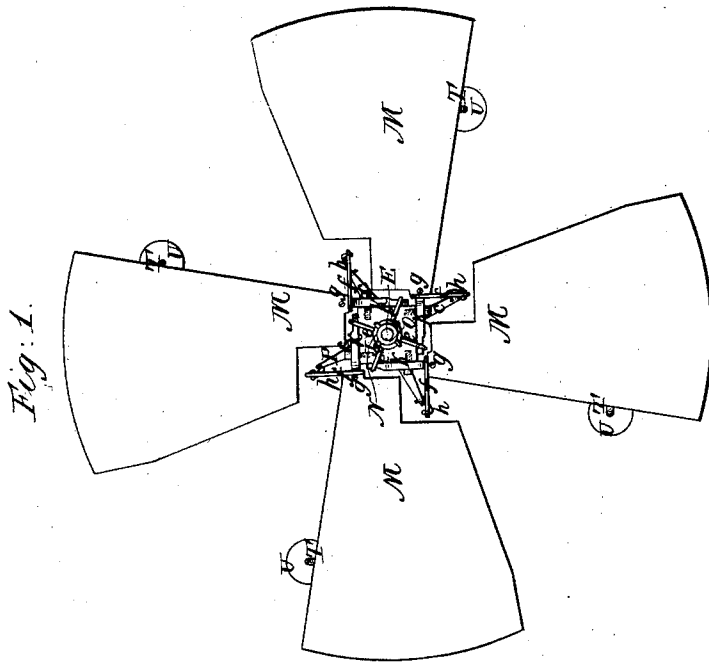

Fig. 1.



Fig. 5.

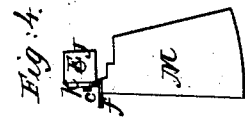

Fig. 4.

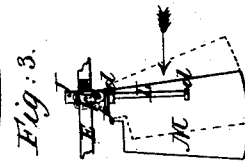

Fig. 3.

UNITED STATES PATENT OFFICE.

JAMES MITCHELL, OF WOODSFIELD, OHIO.

IMPROVED WIND-WHEEL.

Specification forming part of Letters Patent No. 17,384, dated May 26, 1857.

To all whom it may concern:

Be it known that I, JAMES MITCHELL, of Woodsfield, in the county of Monroe and State of Ohio, have invented certain new and useful Improvements in Wind-Wheels; and I do hereby declare that the following is a full, clear, and exact description of the same, reference being had to the annexed drawings, making a part of this specification, in which—

Figure 1 is a front or face view of my improvement. Fig. 2 is a side view of the same. Figs. 3 and 4 are detached views of a fan in different positions, illustrating the principle of the oblique arms. Fig. 5 is a detached view of a fan and lever, showing the advantages of the mode of attaching the lever to the fan.

Similar letters of reference indicate corresponding parts in the two figures.

This invention relates to certain improvements in that class of wind-wheels in which provision is made for a self-adjustment of the fans, whereby the fans are presented more or less angularly or obliquely to the wind according to its power or velocity, and the wheel consequently made to rotate with an equal speed, however variable the velocity of the wind may be.

The invention consists, first, in placing the arms of the fans obliquely with their shaft, so that they will have a proper degree of inclination to the axis of the shaft, and thereby lessen the centrifugal force, which in the wheels of usual construction has a tendency to spread out the fans as the wheel rotates and prevents the perfect self-adjustment of the same.

The invention consists, second, in the peculiar means employed for regulating the angle of inclination of the arms so that said arms may be adjusted or set more or less angularly with their shaft, as circumstances may require.

To enable those skilled in the art to fully understand and construct my invention, I will proceed to describe it.

A represents an upright frame, on the upper part of which a rotating cap B is fitted, said cap having a vane C attached to it, and also an arm D, the arm and vane being attached to the cap at opposite sides. The arm D serves as a support for a horizontal shaft

E, a bearing *a* being at the outer end of said arm and a bearing *b* at its inner end. To the inner end of the shaft E a crank-pulley G is attached and a piston-rod H is attached to this pulley, said piston-rod being attached to the piston or plunger H' of a pump I. On the shaft E, near its outer end, a square head J is secured, and to each side of this head J a lever K is pivoted, *c* being the pivots or fulcrum-pins. To the outer ends of these levers K arms L are attached, one to each, and on each arm L a fan M is secured, the fans having eyes *d* attached to them, which eyes are fitted on the rods and allowed to turn freely thereon. (See Fig. 2.) The inner end of each lever K is connected by a rod *e* to a sliding head N, which is placed on the end of the shaft E. This head N is operated or moved in and out by a nut O, which works on a screw thereon at the outer end of the shaft. On the lower end of each arm L a lever *f* is placed and secured by a set-screw *g*. These levers *f* are bent or curved so as to form an angle of about eighteen degrees with the planes of the fans, as shown in Fig. 2. The outer ends of the levers *f* are connected by rods *h* with a sliding head P, which is fitted on the shaft E and has a bar Q attached to it, said bar working or sliding through guides *i i'*, and having a fork at its end, said fork being fitted in a groove in the hub of the collar P. To the end of the bar Q a cord or chain *j* is attached. This cord or chain passes over a pulley *k* in an upright *l* on the cap B, and has a weight or buoy R, attached to its lower end. This weight or buoy is a hollow can containing a requisite quantity of shot, and the buoy is placed within a water-reservoir S, into which the pump I discharges. To the bar Q there is also attached a cord or chain *m*, said cord being attached to the bar Q at the pivot *n*. This cord or chain *m* passes over a pulley *o* and has a small weight *p* attached to its lower end.

The fans M are placed on the arms L out of center, as shown clearly in Fig. 2, and to the back side of each fan M a rod T is attached at right angles. These rods have screw-threads cut on them, and a weight U is fitted on each screw-rod. By turning these weights they may be adjusted nearer to or farther from the fans M.

The weight or buoy R is the exponent of the power of the mill. When the wheel is in operation, the pump I discharges into the reservoir S, and when the reservoir is filled or the requisite quantity of water pumped into it the wind-wheel will stop, because the buoy R will be carried by the water in the reservoir S and the fans M will be turned edgewise to the wind. The water it will be seen causes the buoy to cease to act as a weight. When the water falls in the reservoir, the weight or buoy will of course descend and turn the fans to the wind, so that the reservoir may be again filled.

The wind-wheel may be stopped at any time irrespective of the weight or float R by pulling the small weight *p*. By this means the edges of the fans will be turned to the wind. When the wind has considerable velocity, the weight R will be raised and the fans M thrown or turned somewhat back by the force of the wind, so that a less area is presented to its action. The reverse takes place during a moderate breeze, the weight then keeps the fans turned toward the wind, so that a greater area or surface is presented to it. By this means the wind-wheel is made to rotate with an equal speed, however variable the velocity of the wind may be. The great difficulty, however, in the perfect self-adjustment of the fans is the tendency of the fans to spread out as the wheel rotates. This tendency is caused by centrifugal force generated by the rotation of the wheel. This spreading out of the fans is illustrated in Figs. 3 and 4. If the arms L project from the shaft E at right angles, as they do in all wheels hitherto constructed, the fans will have a tendency to turn on their arms L and remain in the position as shown in Fig. 4—that is, as the wheel rotates. It will be seen, therefore, that this tendency of the fans serves in a measure to neutralize the effect of the weight R, and consequently the fans cannot be perfectly self-adjustable. I obviate this difficulty by having the arms L placed obliquely with the shaft E, so that the outer ends of the fans will project over or be further outward than their lower ends, as shown in red, Fig. 3. This position of the fans completely neutralizes the centrifugal force by which the fans have a tendency to spread out, as described, and the weight R, therefore, will not be acted upon by any extraneous force or power to prevent its perfect operation.

The precise oblique position of the arms L

may vary according to circumstances, and hence it is important that the arms L be capable of adjustment. This is effected by connecting the outer ends of the levers K with the sliding collar N, by operating which the proper degree of inclination may be given the arms.

There is another objection attending the usual self-regulating wind-wheels—viz., the turning of the fans on the arms. The levers that have been usually employed have been attached to the inner ends of the fans and in the same plane with them. (See dotted line, Fig. 5^a, representing the lever as usually placed or attached to the fan.) By this arrangement or mode of attachment of the levers to the fans considerable force is required to turn them at first, the power required gradually decreasing as the lever assumes a right-angular position with its rod *b*. By having the lever *f* bent or curved or so adjusted as to be placed angularly with the fans this objection is obviated, and the levers may be adjusted more or less angularly and secured at the desired pivot by the set-screw *g*. The weights U on the rods T also serve to contract the centrifugal force and the spreading out of the sails, and these weights may be made to act with more or less efficiency, as required, by adjusting the weights U upon the rods T.

I am aware that weights have been applied to the fans of said wheels and connected to sliding heads and so arranged as to render them self-regulating. I do not claim, therefore, a weight thus applied. Neither do I claim the levers *f* applied to the fans, as shown, nor the stopping-cord *m*, for they or their equivalents have been previously used; but

Having described my invention, what I claim as new, and desire to secure by Letters Patent, is—

1. Placing the arms L of the fans obliquely so as to have a proper degree of inclination with the shaft E, for the purpose herein specified.
2. Attaching the arms L to the levers K and connecting said levers to the sliding collar N, operated, as shown, for the purpose of adjusting the arms L more or less obliquely with the shaft E, as desired.

JAMES MITCHELL.

Witnesses:

DANE WALTON,
NATHAN HOLLISTER.