

(19) World Intellectual Property Organization
International Bureau



(43) International Publication Date
13 September 2007 (13.09.2007)

PCT

(10) International Publication Number
WO 2007/102088 A2

- (51) International Patent Classification: **Not classified**
- (21) International Application Number: PCT/IB2007/001705
- (22) International Filing Date: 14 February 2007 (14.02.2007)
- (25) Filing Language: English
- (26) Publication Language: English
- (30) Priority Data:
0604467.1 6 March 2006 (06.03.2006) GB
0608944.5 5 May 2006 (05.05.2006) GB
- (71) Applicant (for all designated States except US): **DELPHI TECHNOLOGIES, INC.** [US/US]; P.O. Box 5052, Troy, MI 48007 (US).
- (72) Inventors; and
- (75) Inventors/Applicants (for US only): **BOSCH, Russell** [US/US]; 12152 Hoisington Road, Gaines, MI 48436 (US). **BERLEMONT, Jean-François** [BE/BE]; Avenue Sitenon, 1, B-1020 Bruxelles (BE).
- (74) Agent: **KELTIE**; Fleet Place House, 2 Fleet Place, London EC4M 7ET (GB).
- (81) Designated States (unless otherwise indicated, for every kind of national protection available): AE, AG, AL, AM, AT, AU, AZ, BA, BB, BG, BR, BW, BY, BZ, CA, CH, CN, CO, CR, CU, CZ, DE, DK, DM, DZ, EC, EE, EG, ES, FI, GB, GD, GE, GH, GM, GT, HN, HR, HU, ID, IL, IN, IS, JP, KE, KG, KM, KN, KP, KR, KZ, LA, LC, LK, LR, LS, LT, LU, LV, LY, MA, MD, MG, MK, MN, MW, MX, MY, MZ, NA, NG, NI, NO, NZ, OM, PG, PH, PL, PT, RO, RS, RU, SC, SD, SE, SG, SK, SL, SM, SV, SY, TJ, TM, TN, TR, TT, TZ, UA, UG, US, UZ, VC, VN, ZA, ZM, ZW.
- (84) Designated States (unless otherwise indicated, for every kind of regional protection available): ARIPO (BW, GH, GM, KE, LS, MW, MZ, NA, SD, SL, SZ, TZ, UG, ZM, ZW), Eurasian (AM, AZ, BY, KG, KZ, MD, RU, TJ, TM), European (AT, BE, BG, CH, CY, CZ, DE, DK, EE, ES, FI, FR, GB, GR, HU, IE, IS, IT, LT, LU, LV, MC, NL, PL, PT, RO, SE, SI, SK, TR), OAPI (BF, BJ, CF, CG, CI, CM, GA, GN, GQ, GW, ML, MR, NE, SN, TD, TG).

[Continued on next page]

(54) Title: ENCAPSULATING ARRANGEMENT FOR AN ELECTRICAL COMPONENT

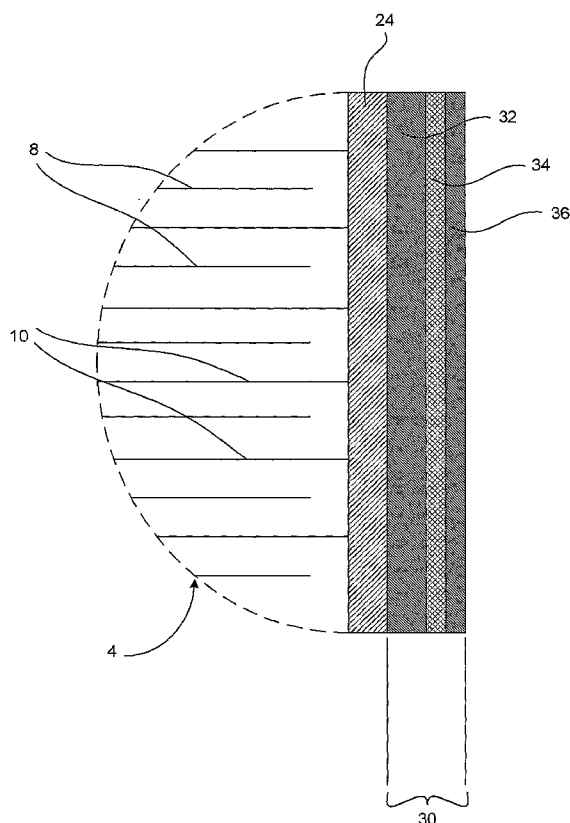

(57) Abstract: The invention provides an encapsulating arrangement (30) for an electrical component comprising first and second insulating layers (32, 36) and an electrically charged conductive layer (34), preferably in the form of a metal foil, intermediate the first and second insulating layers (32, 36), and arranged to prevent the passage of ionic species across the encapsulating arrangement (30). The encapsulating arrangement (30) of the invention has particular application to piezoelectric actuator arrangements for fuel injectors of internal combustion engines.

WO 2007/102088 A2



Published:

— without international search report and to be republished upon receipt of that report

For two-letter codes and other abbreviations, refer to the "Guidance Notes on Codes and Abbreviations" appearing at the beginning of each regular issue of the PCT Gazette.

ENCAPSULATING ARRANGEMENT
FOR AN ELECTRICAL COMPONENT

5 **Technical Field**

The invention relates to an encapsulating arrangement for use in protectively coating an electrical component. In particular, though not exclusively, the invention relates to an encapsulating arrangement for a piezoelectric actuator of an automotive fuel injector.

10

Background to the Invention

Automotive equipment manufacturers are under constant pressure to improve the fuel efficiency of diesel engines and to reduce harmful exhaust gases in order to lessen the environmental impact of their vehicles.

15

A key part of meeting this challenge is the development of piezoelectric fuel injectors. In an automotive engine, such a fuel injector is used to deliver a charge of fuel into an associated combustion cylinder. Typically, an engine will include several such cylinder and injector pairs – usually four, six or eight. A piezoelectric fuel injector offers precise controllability of the amount of fuel delivered into its associated combustion cylinder and, as such, is particularly suited to the demands of a diesel engine.

20

In some piezoelectric injectors, a piezoelectric actuator is housed in a fuel filled chamber defined within the injector such that the actuator is surrounded by liquid fuel at high pressure, typically between 200 and above 2000 bar. An injector of this type is described, for example, in the Applicant's European Patent No. 995901.

25

Although locating the piezoelectric actuator within such a fuel filled chamber is beneficial for several reasons, such an arrangement has associated drawbacks. In

30

particular, the fuel surrounding the actuator contains injurious components that are capable of damaging the actuator if it is not adequately protected.

The invention is therefore directed to improving the ability of electrical components, particularly piezoelectric actuators, from chemically aggressive environments in which they may be disposed, in use.

Summary of the Invention

Against this background, the invention provides an encapsulating arrangement for an electrical component, the encapsulating arrangement comprising first and second insulating layers and an electrically charged conductive layer disposed intermediate the first and second layers to prevent the passage of ionic species across the encapsulating arrangement.

15

It is preferred that the first and second insulating layers are polymeric materials to provide good electrical insulation and good resistance to chemical attack from the environment in which the electrical component is located, in use. However, the use of polymeric material, exclusively, is not essential to the invention.

20

Although the invention is applicable to encapsulating electronic components in general, especially if they are required to operate in chemically aggressive environments, the invention conveys particular benefits in the context of piezoelectric actuators of automotive fuel injection equipment.

25

In this context, it is known to encapsulate piezoelectric actuators in polymeric material in order to protect the actuators from moisture bearing environments. For example, in the injector described in the Applicant's European Patent No. 995901, the piezoelectric actuator is immersed in a pressurised fuel volume defined within the injector body.

30

However, although a polymeric insulating layer is relatively adept at protecting the actuator from high pressure fluids, it is possible that ionic species are able to permeate the insulating layer and cause damage to the stack. The electrically charged conductive layer of the invention therefore provides an ionic diffusion barrier to prevent the transport of ionic species present as contaminants, in fuel for instance, that may otherwise come into contact with an encapsulated electrical component.

It is preferable that the conductive layer is a metal. Any suitable metal can be used to form the conductive layer, such as copper, aluminium, iron, steel, nickel, cobalt, silver, gold or an alloy thereof.

It will be appreciated that the metal should remain in a solid state over the operating temperature range of the electrical component to be encapsulated.

More particularly, it is preferred that the conductive layer is a self-supporting, or self-standing, metal foil. A self-supporting metal foil is advantageous in that it is a cost effective means to provide the actuator with an ionic barrier and is relatively simple to manufacture by wrapping the foil around the component. The metal foil may be in the form of a wide sheet having a width comparable to the length of the actuator, or in the form of a relatively narrow band or tape, in which case it may be wrapped helically around the stack, either in a single layer, or in an overlapped manner in order to provide a layer of increased thickness.

In an alternative embodiment, the conductive layer is a metallic film that is carried on a non-conductive self-supporting substrate such as a polymer membrane or film to form a composite. In a further embodiment of the invention the conductive layer may be formed directly onto the first or second non-conductive layers via techniques known in the art such as vapour deposition, electroless plating, electroplating or sputtering.

Such a metallic film provides a conductive layer of reduced thickness compared with a self-supporting metal foil, which may be advantageous in terms of packaging the electronic component in a confined space.

5 In the preferred embodiment, the conductive layer is substantially continuous and covers substantially the entire surface of the electrical component such that a physical permeation barrier is formed in addition to an electrical shield. However, this may not necessarily be the case and, in an alternative arrangement, the conductive layer may be discontinuous. In other words, the physical coverage of the conductive layer over the
10 surface of the electrical component is intermittent. In this alternative arrangement, the discontinuous conductive layer may be in the form of a wrapping, or a mesh, net, grid or foam, for example.

In a second aspect, the invention provides an electrical component that is protected by
15 an encapsulating arrangement as described above. Preferably, the electrical component is a piezoelectric device in the form of an actuator for use within an automotive fuel injector.

The piezoelectric device may include charging means to permit charging of the
20 conductive layer at least during operation of the device. Preferably, the charging means includes an electrical connector arrangement having first and second terminals for supplying an electrical voltage across positive and negative external electrodes of the piezoelectric device. In this embodiment, the charging means further includes connection means to enable electrical connection between the conductive layer and one
25 of the positive or negative external electrodes of the device.

Although the connection between the conductive layer and the external electrode may be provided in many ways, for example a metal connector spanning across the first insulating layer, for simplicity it is preferred that the connection means includes a

window defined by the first insulating layer such that the external electrode and the conductive layer are able to contact one another.

5 In an alternative arrangement, the conductive layer may be connected to a separate voltage source, for example provided by a third terminal through the connector arrangement. A separate means to charge the conductive layer permits greater flexibility in the charging profile provided to the conductive layer. For example, the conductive layer may be arranged to receive constant, or alternating, charging waveforms. A further possibility is for the separate voltage source to be arranged to
10 charge the conductive layer even after the engine ignition has been turned off so as to provide continued ionic protection for the device. To this end, the third terminal may be connected to an uninterruptible power supply, for example the vehicle battery.

15 In a further alternative embodiment, the conductive layer is connected to an earthed component of the device or may be charged through mutual capacitance with the piezoelectric device.

In a third aspect, the invention provides a fuel injector incorporating a piezoelectric device as described above in relation to the first and second aspects.

20

Brief Description of the Drawings

Figure 1 is a perspective view of a known piezoelectric actuator stack; and

25 Figure 2 is a sectional view of the actuator of Figure 1 along the line A-A being provided with an encapsulating arrangement in accordance with an embodiment of the invention.

30

Detailed Description of the Preferred Embodiments

Referring to Figure 1, a known piezoelectric device in the form of an actuator arrangement 2 includes a piezoelectric stack 4 comprising a plurality of layers 6 formed of a ferroelectric material, for example Lead Zirconate Titanate (PZT). Each layer 6 is separated from its adjacent layer or layers within the stack 4 by internal electrodes 8, 10 that are interdigitated with the piezoelectric layers 6 so as to form an alternating sequence of positive and negative internal electrodes 8, 10, respectively. Each adjacent pair of positive and negative internal electrodes 8, 10 therefore sandwiches a respective piezoelectric layer 6, which exhibits a mechanical strain in response to a voltage applied across the positive and negative internal electrodes 8, 10.

Each positive internal electrode 8 terminates at a positive face 12 of the stack 4 and each negative internal electrode 10 terminates at a negative face 14 of the stack 4. The positive and negative faces 12, 14 of the stack 4 bear respective positive and negative metallised regions 16, 18 that extend across a portion of the stack surface such that the positive metallic region 16 electrically connects the positive internal electrodes 8 and the negative metallised region 18 electrically connects the negative internal electrodes 10.

The stack 4 is also provided with an electrical passivation layer 20 that covers substantially the entire surface of the stack 4, except for the positive and negative metallic regions 16, 18. The function of the passivation layer 20 is to insulate the edges of the internal electrodes 8, 10 that emerge at the stack surface and so guard against surface flashovers due to the high voltages applied to the internal electrode layers 8, 10. A suitable material for the passivation layer 20 is a polyimide film such as Kapton™ by DuPont due to its high dielectric strength yet low thickness and weight.

In order to enable supply of an electrical voltage to the internal electrodes 8, 10 of the stack 4, a positive external electrode 22 is attached to the positive metallised region 16

and a negative external electrode 24 is attached to the negative metallised region 18. In use, the positive and negative external electrodes 22, 24 are connected to a power source via a connector module (not shown) mounted atop the stack 4 by which means a variable voltage is applied to the positive and negative internal electrodes 8, 10 to control expansion and contraction of the stack 4.

Figure 2 shows a sectional view of the stack 4 of Figure 1 bearing a multi-layered encapsulating arrangement 30 in accordance with an embodiment of the invention. It should be appreciated that the scale of the stack 4 and the encapsulating arrangement 30 shown in Figure 2 is greatly exaggerated here for the purposes of clarity. The encapsulating arrangement 30 provides a means of protecting the relatively brittle piezoelectric material of the stack 4 from an aggressive operational environment.

In this embodiment, the encapsulating arrangement 30 is a laminated structure comprising three separate encapsulating layers. The first encapsulating layer 32 is an insulating layer that is arranged to completely envelop the surface of the stack 4 and the external electrodes 22, 24 that are exposed to the external environment, in use (only the negative external electrode 24 is shown in Figure 2). It is important that the first insulating layer 32 provides good electrical insulation properties, high strength and high temperature resistance. A suitable material for the first insulating layer 32 is a polymeric material, such as PTFE/ETFE, in the form of a heat-shrinkable self-supporting film or sleeve that contracts upon the application of heat to fit tightly the profile of the stack 4. A standard electrical grade adhesive may be applied to the insulating layer 32 to improve its adhesion to the stack surface.

The second encapsulating layer 34 is an electrically conductive layer that is adapted to be impermeable to the through passage of ionic species. The conductive layer 34 is prevented from contacting the external electrodes 22, 24 by the first insulating layer 32. The conductive layer will be described in further detail later.

30

The third, and final, encapsulating layer 36 in this embodiment is a second insulating layer that is arranged to completely encapsulate the electrically conductive layer 34, thus serving to insulate the conductive layer 34 from the external environment, in use. As with the first insulating layer 32, a suitable material for the second insulating layer 36 is an organic polymeric material, such as PTFE/ETFE, in the form of a heat-shrinkable self-supporting film or sleeve.

Returning to the electrically conductive layer 34, in this embodiment the conductive layer 34 comprises a self-supporting metal foil, for example aluminium foil, having a thickness of approximately 10 μ m. The foil layer 34 is wrapped around the stack 4 encapsulated by the first insulating layer 32 to form a substantially continuous, or unbroken, metallic barrier. To ensure good adhesion, adhesive is applied to the ends of the stack 4 to secure the foil layer 34 to the first insulating layer 32. It should be mentioned at this point that other thicknesses of metal foil could also be used, for example above or below 10 μ m. It is important, however, that the thickness of the metal foil lends itself to convenient application to the stack.

Although not shown in Figure 2, the first insulating layer 32 is provided with a window that exposes a portion of the positive external electrode 24. The positive external electrode 24 therefore contacts the electrically conductive layer 34 in this region by which means the conductive layer 34 is provided with a positive voltage potential. The positively charged conductive layer 34 repels ions of like polarity, in this case anions, whilst attracting and sequestering oppositely charged ions, in this case cations. The conductive layer 34 therefore functions as an ionic shield that prevents ionic species present in the fuel permeating through the encapsulating arrangement 30 and into the structure of the stack 4.

In the preferred embodiment of the invention mentioned above, the conductive layer 34 is connected to the positive terminal of the connector module by contacting the positive external electrode 24 of the stack 4. It should be appreciated, however, that this is just

one way of charging the ionic shield and variations are possible within the inventive concept.

5 For example, the electrically conductive layer 34 may, instead, be connected to the negative terminal of the connector module by contacting the negative external electrode 22 of the stack 4. In this case, the electrically conductive layer 34 would attract anions and repel cations.

10 Still alternatively, the conductive layer 34 may be connected to a third, dedicated terminal, provided by the connector module for example, through which the conductive layer 34 could be provided with an optimum voltage level adapted specifically for a particular circumstance. For example, in some circumstances it may be preferable to provide the electrically conductive layer 34 with a constant voltage of a predetermined magnitude. Conversely, in other circumstances, it may be preferable to provide the
15 conductive layer 34 with a variable voltage, in the form of a square waveform, or a sinusoidal waveform, for example.

The provision of a dedicated voltage terminal for connecting to the conductive layer 34 provides the advantage that a voltage may still be supplied to the ionic shield after the
20 engine has been shut down. For example, the third terminal could be connected to an uninterruptible power supply, for example the vehicle battery, in circumstances when the engine ignition is off in order to provide a level of residual protection to the stack 4 even when the injectors are not operating.

25 A further alternative is to connect the conductive layer 34 to an earthed component of the actuator 2, for example a steel end member (not shown) which is in direct contact with earthed components of the injector.

It will be apparent from the above described arrangements that the electrically
30 conductive layer 34 is provided with a connection to either electrical ground or a

voltage source. However, in some circumstances, it may be sufficient to omit such an electrical connection such that the electrically conductive layer 34 is charged through mutual capacitance due to the proximity of the conductive layer 34 to the internal electrodes 8, 10, metallised region 16, 18 and external electrodes 22, 24 of the stack. In such an arrangement, the conductive layer 34 is at a floating voltage with respect to the voltage of the injector body in which it is housed. Typically the injector body is at ground potential by virtue of its earthed connection to the engine in which it is installed.

There can also be variations in the structure of the electrically conductive layer 34. For example, instead of a self-supporting metal foil, the electrically conductive layer 34 may also take the form of a metallised coating that is applied to a supporting substrate such as a polymer membrane or film to form a composite. The metallic coating may be applied to the supporting substrate via known techniques such as vapour deposition or sputtering. Also, it should be appreciated that the supporting substrate may be the first or second insulating layers 32, 36.

Such a metallic coating will be thinner than a self-supporting metal foil, typically in the range of 50 nm to 10 μm , although this range should not be construed as limiting. A thinner conductive layer 34 achievable by way of a metallic coating has the advantage of minimising the lateral cross section of the encapsulated actuator 2. This is particularly important if the actuator is required to be installed within a relatively small space.

All of the above described arrangements provide a continuous, or unbroken electrically conductive layer 34 that present a physical, as well as an electrical, barrier to ionic species. However, in an alternative arrangement (not shown), the conductive layer 34 is configured in the form of an open structure, such as a grid, mesh, net or a metal foam. Another alternative is a spaced winding to provide a discontinuous layer, for example a metal tape wound helically around the stack. Such a structure provides the same ion-sequestering advantages as encapsulating the entire stack with a continuous conductive

layer 34 but uses less material thus providing a relatively low cost alternative. This advantage is particularly important if higher cost materials are used.

CLAIMS

1. An encapsulating arrangement (30) for an electrical component comprising:
5 first and second insulating layers (32, 36); and

an electrically charged conductive layer (34) intermediate the first and second insulating layers (32, 36) arranged to prevent the passage of ionic species across the encapsulating arrangement (30).
10
2. The encapsulating arrangement (30) of claim 1, wherein the conductive layer (34) is a metal.
3. The encapsulating arrangement (30) of claim 1 or claim 2, wherein the
15 conductive layer (34) is a self-supporting metal foil.
4. The encapsulating arrangement (30) of claim 1 or claim 2, wherein the conductive layer (34) is a metallic film carried on a non-conductive supporting substrate.
20
5. The encapsulating arrangement (30) of claim 4, wherein the non-conductive supporting substrate is the first or second insulating layer (32, 36).
6. The encapsulating arrangement (30) of any one of the preceding claims, wherein
25 the conductive layer (34) is substantially continuous.
7. The encapsulating arrangement (30) of any one of the preceding claims, wherein the conductive layer (34) is discontinuous.

8. The encapsulating arrangement of claim 7, wherein the discontinuous conductive layer (34) is in the form of a net, mesh, grid or foam.
9. An electrical component protected by an encapsulating arrangement (30) as
5 claimed in any one of the preceding claims.
10. The electrical component of claim 9, wherein the electrical component is a piezoelectric device (2).
- 10 11. The piezoelectric device of claim 10, including charging means to permit charging of the conductive layer (34) at least during operation of the piezoelectric device.
12. The piezoelectric device of claim 11, wherein the charging means includes an
15 electrical connector arrangement for connecting the device to a power source.
13. The piezoelectric device of claim 12, including first and second external electrodes (22, 24) for generating an electrical field across the device when the device is connected to the power source, in use, wherein the electrical connector
20 arrangement includes first and second electrical terminals connected, respectively, to the first and second external electrodes (22, 24).
14. The piezoelectric device of claim 13, wherein the charging means further
25 includes connection means to enable electrical connection between the conductive layer (34) and one of said external electrodes (22, 24).
15. The piezoelectric device of claim 14, wherein the connection means includes a window defined by the first insulating layer (32).

16. The piezoelectric device of any one of claims 13 to 15, wherein the electrical connector arrangement is provided with a third terminal in electrical contact with the conductive layer (34).
- 5 17. The piezoelectric device of claim 16, wherein the third terminal is provided with a connection to an uninterruptible power supply to enable charging of the conductive layer (34) in circumstances when the first and second electrical terminals are inoperative.
- 10 18. The piezoelectric device (2) of claim 10, wherein the conductive layer (34) is charged through mutual capacitance with the device (2).
19. The piezoelectric device of claim 10, including an earthed component, wherein the conductive layer (34) is connected to the earthed component.
- 15 20. A fuel injector incorporating the piezoelectric device of any one of claims 10 to 19.

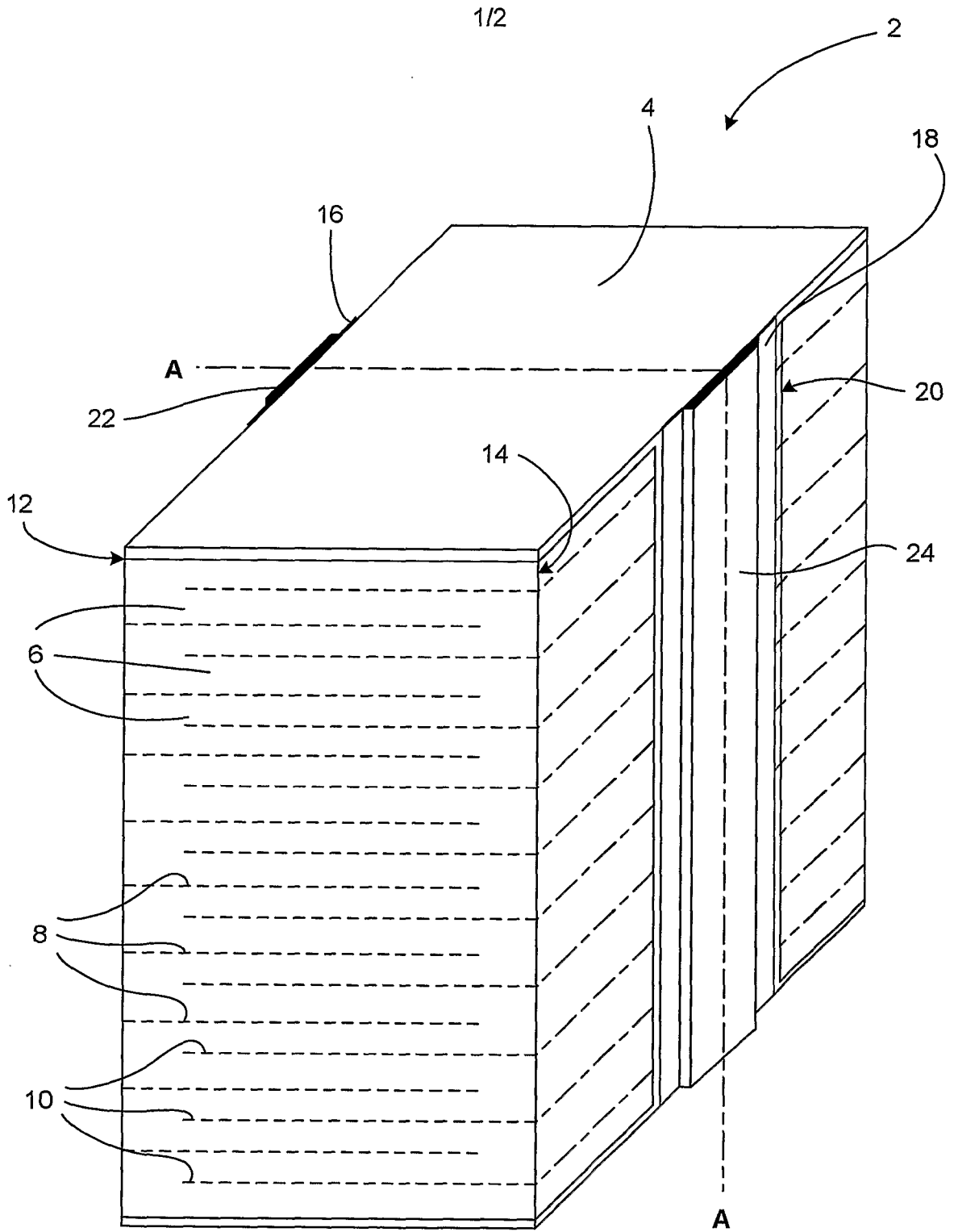

FIG. 1

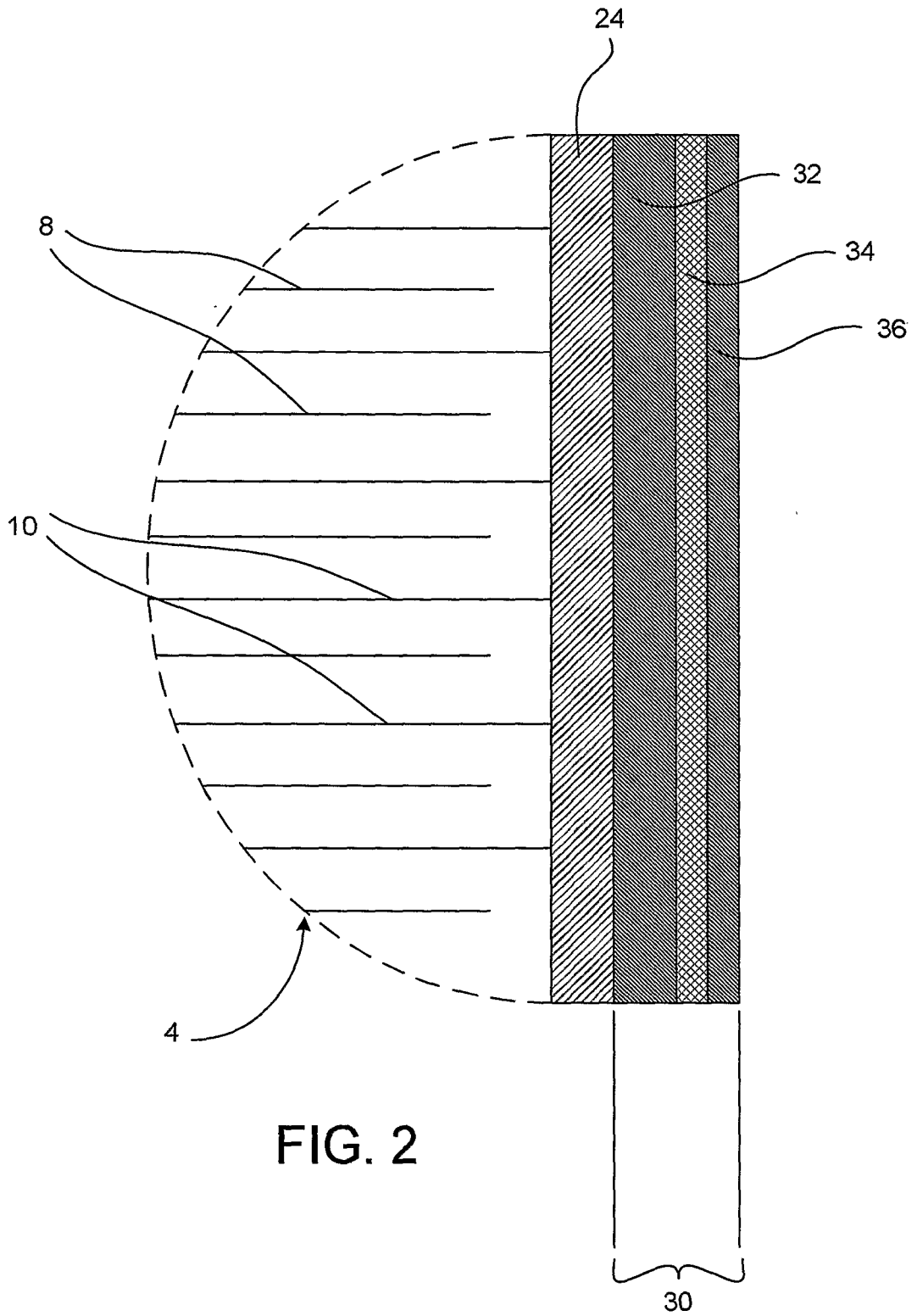

FIG. 2