

(No Model.)

W. LOEB.
BUTTON OR STUD.

No. 416,470.

Patented Dec. 3, 1889.

Fig. 1.

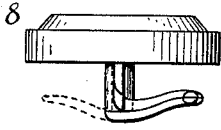

Fig. 2.

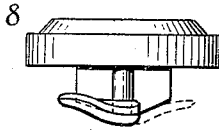

Fig. 3.

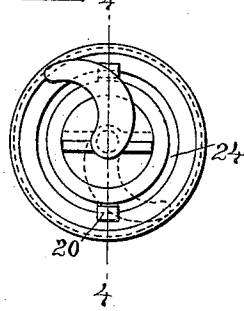

Fig. 4.

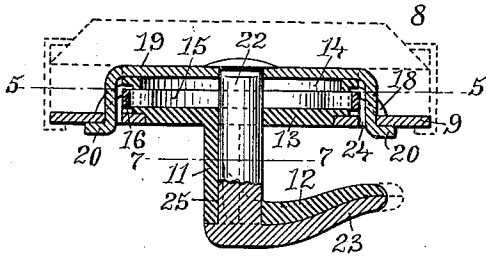

Fig. 5.

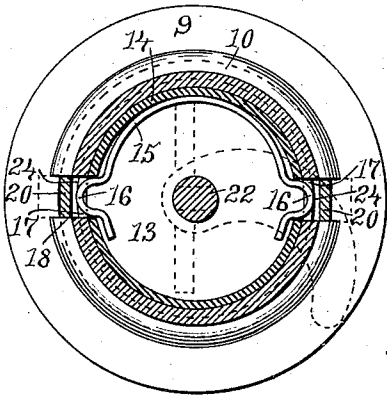

Fig. 6.

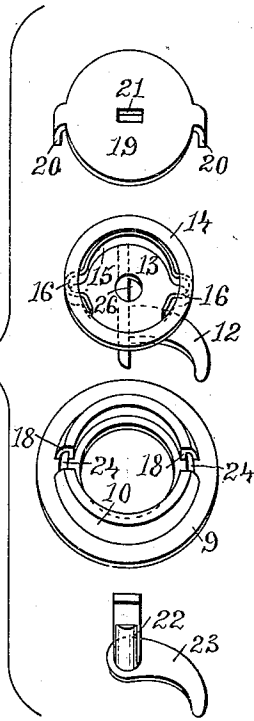
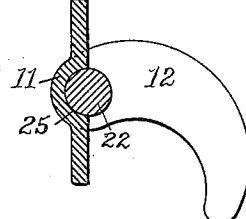

Fig. 7.



WITNESSES:

M. F. Bligh
Chas. H. Luther Jr

INVENTOR:

William Loeb
by Joseph A. Miller & Co.

UNITED STATES PATENT OFFICE.

WILLIAM LOEB, OF PROVIDENCE, RHODE ISLAND.

BUTTON OR STUD.

SPECIFICATION forming part of Letters Patent No. 416,470, dated December 3, 1889.

Application filed March 18, 1889. Serial No. 303,661. (No model.)

To all whom it may concern:

Be it known that I, WILLIAM LOEB, of Providence, in the county of Providence and State of Rhode Island, have invented certain new and useful Improvements in Buttons or Studs, of which the following is a full, clear, and exact description, reference being had to the accompanying drawings, forming part of this specification.

My invention relates to the class of buttons known as "cuff-buttons;" but the invention is also applicable to collar-buttons or studs by simply reducing the size of the various parts of the device to conform to the size of the button or stud to be produced.

The object of my invention is to provide a button which may be easily and readily inserted and fastened to the cuff and as readily removed therefrom without danger of the loss of any part thereof.

To the above purpose my invention consists in the arrangement and combination of the several parts of the button, as will be more fully set forth hereinafter.

In the accompanying drawings, Figure 1 is a side view of the button, looking at the edge of the wings. Fig. 2 is a side view of the button, looking at the side of the wings. Fig. 3 is a plan view of the under side of the button. Fig. 4 is a sectional view taken on the line 4 4 of Fig. 3. Fig. 5 is a sectional view taken on the line 5 5 of Fig. 4. Fig. 6 is perspective view of the individual parts of the button. Fig. 7 is a sectional view taken on the line 7 7 of Fig. 4, the fixed post being removed.

In the said drawings like numbers of reference designate corresponding parts throughout.

Referring to the drawings, 8 designates the head of the button. To the under side of the head of the button the back plate 9 is attached. This plate 9 has the raised rib 10 formed thereon by striking up the plate in suitable dies. The winged post 11, carrying the curved shoe 12, is securely attached to the under side of the spring-plate 13, which is provided with the upwardly and outwardly extending flange 14. In the cavity formed by the upwardly-extending flange the spring 15, having the outwardly-bent ends 16 16, is

placed, the bent ends 16 16 of the spring extending outwardly through the holes or openings 17 17, formed in the sides of the flange 14, and entering the slots 18 18, cut in the rib 10, formed on the back plate 9. The top plate or cover 19 is provided with the two lugs 20 20 and the oblong hole 21. The fixed post 22 has its upper end formed to fit the hole 21, and its lower end is attached to the curved shoe 23. The two curved shoes 12 and 23 are of the same shape and size, one fitting directly under the other when they are in the closed position. They are also bent or shaped in the form of a spiral, so as to more readily enter the button-holes of the article to which they are to be attached.

The construction of the button is as follows: The spring-plate 13, having the winged post 11, provided with the curved shoe 12, is placed in position by passing the curved shoe 12 and winged post 11 through the hole in the center of the plate 9, thereby allowing the spring-plate 13 to rest on the plate 9. The two lugs 20 20 are then passed through the holes 24 24, formed in the plate 9, the ends of the lugs then being either turned over or riveted, after which the post 22 is passed up through the hole 25 in the shoe 12, through the hole 26 in the spring-plate, and the upper end then passes through the hole 21 in the plate 19, when it is riveted and securely held in place, the shoe 23 fitting snugly under the shoe 12.

The operation of the button is as follows: The free ends of the shoes are passed through the button-holes, in which action they have a slight spiral motion, until the winged post has entered lengthwise into the button-hole, after which the head is turned, causing the ends of the spring to move inward out of the slots and the shoe 23 to turn with the head until a half-revolution of the head is made and the shoe has assumed the position shown in Figs. 1, 2, and 3, when the bent ends of the spring will snap out into their respective slots and securely hold the button in position.

Having thus described my invention, I claim as new and desire to secure by Letters Patent—

1. In a detachable button or stud, the combination, with a back plate rigidly secured to the button, a circular rib slotted on opposite

points, and a post secured to the back-plate provided with a curved shoe, of a spring-plate, a slotted cylindrical projection on the spring-plate, a winged post secured to and turning
5 with the spring-plate, and the spring 15, constructed to enter the slots in the cylindrical rim of the spring-plate, as described.

2. In a detachable button or stud, the combination of the plate 9, having the rib 10, provided with the slots or openings 18 18, the
10 spring-plate 13, having the winged post 11, provided with the shoe 12, attached thereto,

the spring 15, having the bent ends 16 16, the plate 19, secured to the back plate by the lugs 20 20, and the post 22, provided with the shoe 23, the end of which post is secured in the hole 21, all substantially as herein shown and described. 15

In witness whereof I have hereunto set my hand.

WILLIAM LOEB.

Witnesses:

M. F. BLIGH,

J. A. MILLER, Jr.