

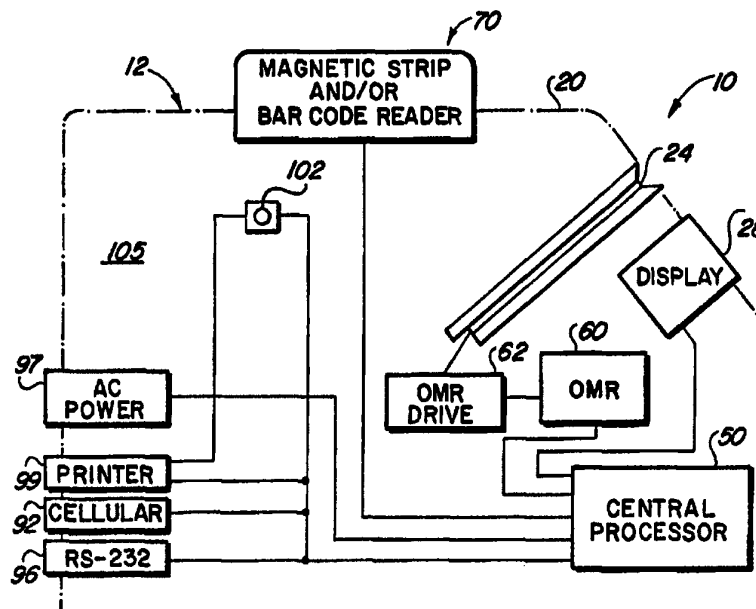

INTERNATIONAL APPLICATION PUBLISHED UNDER THE PATENT COOPERATION TREATY (PCT)

<p>(51) International Patent Classification <sup>6</sup> : <b>G06F 17/60</b></p>	<p>A1</p>	<p>(11) International Publication Number: <b>WO 96/42061</b> (43) International Publication Date: 27 December 1996 (27.12.96)</p>
<p>(21) International Application Number: PCT/US95/12297 (22) International Filing Date: 25 September 1995 (25.09.95) (30) Priority Data: 08/490,050 13 June 1995 (13.06.95) US (71)(72) Applicant and Inventor: CHUMBLEY, Gregory, R. [US/US]; Suite 902, 2999 Concorde Centre Drive, Miami, FL 33180 (US). (74) Agent: DOWNEY, Robert, M.; Robert M. Downey, P.A., Suite 1480, 701 Brickell Avenue, Miami, FL 33131 (US).</p>		<p>(81) Designated States: BR, JP, MX, European patent (AT, BE, CH, DE, DK, ES, FR, GB, GR, IE, IT, LU, MC, NL, PT, SE).  <b>Published</b> <i>With international search report.</i></p>

(54) Title: DATA COLLECTION DEVICE



(57) Abstract

A data collection device (10) for collecting polling data includes a housing (12), a visual character display (28) and slot opening (24) on the front face of the device. A central processor (50) stores data, including preprogrammed data and collected data in a primary memory, and controls operation of the components of the device, such as optical mark reader (60). The optical mark reader pulls a pre-printed data card through the slot opening for scanning data thereon and transferring the data to the primary memory for storage therein. A bar code reader and/or a magnetic strip reader (70) on the device reads encoded data on a respondent's identification card, so that the encoded data may also be transferred to the primary memory for storage. The device interconnects with external components such as a remote computer (100) and/or printer (99) to generate and print reports based on the collected data.

**FOR THE PURPOSES OF INFORMATION ONLY**

Codes used to identify States party to the PCT on the front pages of pamphlets publishing international applications under the PCT.

AM	Armenia	GB	United Kingdom	MW	Malawi
AT	Austria	GE	Georgia	MX	Mexico
AU	Australia	GN	Guinea	NE	Niger
BB	Barbados	GR	Greece	NL	Netherlands
BE	Belgium	HU	Hungary	NO	Norway
BF	Burkina Faso	IE	Ireland	NZ	New Zealand
BG	Bulgaria	IT	Italy	PL	Poland
BJ	Benin	JP	Japan	PT	Portugal
BR	Brazil	KE	Kenya	RO	Romania
BY	Belarus	KG	Kyrgystan	RU	Russian Federation
CA	Canada	KP	Democratic People's Republic of Korea	SD	Sudan
CF	Central African Republic	KR	Republic of Korea	SE	Sweden
CG	Congo	KZ	Kazakhstan	SG	Singapore
CH	Switzerland	LI	Liechtenstein	SI	Slovenia
CI	Côte d'Ivoire	LK	Sri Lanka	SK	Slovakia
CM	Cameroon	LR	Liberia	SN	Senegal
CN	China	LT	Lithuania	SZ	Swaziland
CS	Czechoslovakia	LU	Luxembourg	TD	Chad
CZ	Czech Republic	LV	Latvia	TG	Togo
DE	Germany	MC	Monaco	TJ	Tajikistan
DK	Denmark	MD	Republic of Moldova	TT	Trinidad and Tobago
EE	Estonia	MG	Madagascar	UA	Ukraine
ES	Spain	ML	Mali	UG	Uganda
FI	Finland	MN	Mongolia	US	United States of America
FR	France	MR	Mauritania	UZ	Uzbekistan
GA	Gabon			VN	Viet Nam

## DATA COLLECTION DEVICE

BACKGROUND OF THE INVENTIONField of the Invention

The present invention relates to data collection devices and, more specifically, to a device for collecting polling data from a data card of the type including a plurality of pre-printed enclosed spaces (or bubbles) intended to be selectively darkened in response to an inquiry, such as on a survey questionnaire or election ballot.

Description of the Related Art

Information is perhaps the most valuable resource to private businesses and governments, particularly information relating to public opinion and consumer satisfaction. However, the collecting of information from the public can be a daunting and expensive task, often requiring the services of a professional market research firm or polling service. Ordinarily, such information is gathered through the use of surveys specifically designed for a particular business, industry, or government agency. In some instances, gathering of information is directed at a particular controlled group of consumers or citizens, while other times it is desirable to determine general public opinion on a particular subject. Further, the election of government officials, whether municipal, county, state, or federal, requires collection and processing of information, in the form of votes, from large sectors of the public, encompassing possibly millions of voters.

In the past, there have been various survey conducting apparatus and other data collection devices developed in the art to facilitate automated collection of data.

Specifically, the U.S. Patent to Cadotte, et al., No. 4,345,315 discloses an electronic terminal for electronically collecting opinion data from consumers of a service organization as to the satisfaction with the services rendered. The terminal includes a keyboard that displays inquiries with multiple choice responses for each inquiry. A response is associated with each key, whereby the respondent presses the appropriate keys in connection with the associated response. A response, by operation of the keys is electronically recorded by a microprocessor controller, visually displaying to the customer each selection. A tally of the answers is permanently recorded in the terminal. Other related devices are disclosed in the patents to Johnson, et al., No. Re. 31,951 and Itoh, et al., No. 5,091,877. These devices are specifically designed to collect data electronically and transmit this data to a central memory.

A common drawback of the devices set forth above is that they require specific programming in order to correlate responses to the questions. Each time the questions to a survey are changed, or a new survey is created, these devices need to be reprogrammed. This procedure is not only time-consuming, but costly and generally requires the services of a person having expertise in programming such devices. Further, the market survey and data collection devices set forth above generally require the user to input responses to questions, using keys, thus requiring a substantial level of interaction with the device, inevitably leading to user error, frustration and/or inaccurate data input.

Accordingly, there is a need for a data collection device which can be conveniently installed, either permanently or temporarily, at virtually any select location and which is simple to operate, requiring only the insertion of a response card by respondents.

### Summary of the Invention

The present invention is directed to a device for collecting data from a data card which is distributed to respondents; the data card being of the type including an array of pre-printed enclosed areas (or bubbles) printed on the card in accordance with a predetermined arrangement and intended to be selectively and individually darkened in response to questions or selections, such as in a survey questionnaire or election ballot.

The device of the present invention includes a housing having a front face, a back panel, a base, and a slot opening in the front face. A central processor unit such as a PC-104 motherboard within an interior of the housing, includes a control circuit for controlling operation of the various components of the device and a memory means for storing data. A visual display means on the housing provides instructional information relating to use and operation of the device. An optical mark reader (OMR) positioned and disposed adjacent to the slot opening within the housing interior is structured to pull the data card through the slot opening for scanning in order to determine the location of the darkened (filled-in) bubbles relative to fixed timing marks along the outer borders of the card. The OMR sends data corresponding with the readings of the darkened bubbles to the central processor for storage in the central processor's memory.

After responding to each inquiry, by darkening the appropriate bubbles with a pen or pencil, the data card is inserted into the OMR. The data card may include a litho code or other identifying indicia along an edge of the card, the litho code corresponding to the particulars of a survey or ballot, such as: a survey or ballot version (i.e., version 1-12); whether the survey is single or double-sided; and whether the language on the character display is to be English, French, German, Spanish, Portuguese, or another language. Accordingly, when a data card is inserted in the device, the OMR reads the litho code thereon, enabling the

central processor to match the data card with these survey or ballot particulars.

A bar code and/or magnetic strip reader is attached to the top of the housing for reading data from a bar code or magnetic strip, such as may be provided on a voter registration or other identification card of the respondent. Upon passing the voter registration or other identification card along the elongate slot of the reader, exposing a bar code or magnetic strip within the slot of the reader, the identification data particular to that respondent is read and thereafter transmitted and stored in the central processor.

With the foregoing in mind, it is a primary object of the present invention to provide a data collection device adapted to read data on a data card, store the data in the central processor, and thereafter print a generated report based on the collected data.

It is a further object of the present invention to provide a device for collecting data as is required for conducting surveys or balloting, wherein the device is designed either for mounting in a fixed, permanent position, or completely portable and supported on a table top or other suitable support surface.

It is still a further object of the present invention to provide a device for collecting data at remote locations for subsequent transfer to a central database in order to generate reports such as the results of a survey or election.

It is yet a further object of the present invention to provide a device for collecting data as is needed to conduct a survey or for balloting, wherein the device includes a bar code reader and/or a magnetic strip reader for reading user specific data as may be encoded on an ID card or voter registration card.

These and other objects of the present invention will be more readily apparent in the description which follows.

### Brief Description of the Drawings

For a fuller understanding of the nature of the present invention, reference should be had to the following detailed description taken in connection with the accompanying drawings in which:

Figure 1 is a front perspective view of the device of the present invention;

Figure 2 is a front elevational view of the device;

Figure 3 is a schematic diagram illustrating the functional relationship of the various components of the device of the present invention;

Figure 4 is a rear elevation of the device illustrating various ports for connecting with external devices including a serial and/or parallel port, a modem port, a power connection port, a printer port, and a cellular connection port;

Figure 5 is a rear perspective view of the device showing an access door on the side thereof;

Figure 6 is a bottom plan view of the device showing an access plate; and

Figure 7 is a schematic diagram of an alternative embodiment of the present invention.

Like reference numerals refer to like parts throughout the several views of the drawings.

### Detailed Description of the Preferred Embodiment

Referring initially to the several figures of the drawings, there is illustrated a data collection device of the present invention, referred to generally as 10. The data collection device 10 includes a housing 12 having a base 14, a front panel 16, opposite sides 17, 18 and a back panel 19. The front panel 16 may be formed and configured to extend from the top edge of the back panel 19 to the base 14, to define a top side 20 and a front face 22. The front face includes a slot opening 24, and a character display 28. The character display 28 provides visual messages to the respondent including instructional information relating to

operation of the device.

Referring to Figure 3, there is schematically illustrated the device 10 of the present invention, including the various component elements thereof which are powered by either AC power or by an internal battery. Specifically, the device 10 includes a central processor 50 including a control circuit for controlling operation of the various components of the device and a memory means for storing data therein. In a preferred embodiment, the central processor unit 50 is a PC-104 motherboard.

The visual character display 28 interconnects with the central processor 50 and receives messages from the central processor's memory for display. The particular messages transmitted from the central processor 50 to the display 28 are prompted by various actions and operations of the various components during use.

An optical mark reader (OMR) 60 supported within the housing 12 interior includes a drive assembly 62 specifically structured to pull the data card through the slot opening 24 and past the OMR 60 for scanning thereof. The OMR 60 is structured to scan and read the data card once pulled therethrough in order to detect and locate darkened areas on the card, including a litho code or other identifying indicia, timing marks, and darkened (filled-in) bubbles. The OMR sends data corresponding with the readings taken from the data card to the central processor for storage in the central processor's memory. This data is thereafter consolidated in the central processor's memory in accordance with the particular litho code identifying the survey or ballot version. Thus, all response data from the scanned data cards is grouped, consolidated and stored for each survey or ballot version.

A bar code and/or magnetic strip reader 70 is fitted to the top side 20 of the housing 12 and includes two parallel, elongate blocks 72, 74 disposed in spaced, parallel relation to define an elongate slot 76 therebetween. Either or both of the blocks 72, 74 may be provided with a magnetic strip



reader and/or bar code scanner element facing inwardly toward the elongate slot 76 so that a magnetic strip or bar code on a card or other substrate can be read upon passing the card along the length of the slot 76 so that the bar code and/or magnetic strip is exposed to the appropriate reading element. In use, respondents submitting a response data card within the device may have a previously issued identification card having a bar code or magnetic strip thereon which is encoded with identification data specific to that particular respondent. When conducting a ballot, for example, when each voter registers, they receive a voter registration card having the bar code or magnetic strip thereon. Upon submitting their ballot into the device 10, in the form of a data card as described above, the voter will also pass their voter registration card through the bar code scanner or magnetic strip reader in order to record the fact that the particular voter has cast his/her vote. This would prove valuable where the voter registration forms were lost, stolen, or destroyed. The identification data read from the bar code or magnetic strip is transmitted and stored in the memory of the central processor 50.

When data cards are submitted, by inserting them through the slot opening 24 to be read by the OMR 60, they may be either rejected or retained after scanning. For balloting purposes, the device will retain the data cards within the housing interior, in a removable bin, after scanning by the OMR. As seen in Figure 5, the housing 12 is provided with an access door 90 on the side panel 17 in order to facilitate access to the housing interior for retrieving deposited data cards. An access plate 101 on the bottom of the device opens by removing screws to enable repair or replacement of hardware components within the housing 12. The housing interior 105 is structured to provide a removable bin for storing approximately 2,000 ballot data cards. A key lock 89 or other suitable lock means enables the door 90 to be secured and locked in the closed position, preventing unauthorized access to the

housing interior.

The back panel 19 is provided with several ports and/or jacks to facilitate interconnection of the device with various external components such as a computer, an external printer, a modem, and a cellular transceiver. In particular, the back panel is provided with a modem port 92 to facilitate transfer of data between an external computer database and the central processor 50 via a telephone line connection. The port 92 further facilitates interconnection with a cellular transceiver enabling transfer of data via a wireless transmission media. An RS-232 serial port 96 facilitates direct connection of external computer devices to the central processor 50. An AC power connection 97 is further provided for connecting the device to an AC power source, which also serves to charge the internal battery supply.

As mentioned earlier, the device 10 can be interconnected with an external printer via a printer port 99. Alternatively, an internal printer may be provided within the device and interconnected with the central processor for on site printing of reports generated by the central processor. In either event, the device 10 is adapted to generate various reports based on the collected data. To obtain printed reports, the operator would depress a button 102 within the housing 12 to activate the internal or externally connected printer. For example, in the instance the device is used for balloting, several reports can be obtained including a printout which lists the voter registration number of each and every voter who used the device to cast his/her ballot, either in the form of numbers or in bar code form. This information would serve as a backup in the event that voter registration documents, signed by the voters at the polling stations, are lost, damaged, destroyed, stolen, or otherwise rendered unreadable. Another report which can be printed by depressing button 102 is a ballot summary providing the polling results.

Referring to figure 7, there is schematically illustrated another embodiment of the device 10 of the present invention, including the various component elements thereof. Specifically, the device 10 in figure 7 includes the central processor unit 50 including a control circuit for controlling operation of the various components of the device and a memory means for storing data therein. In a preferred embodiment, the central processor unit 50 is a PC-104 motherboard.

The visual character display 28 interconnects with the motherboard 50 and receives messages from the motherboard memory for display. The particular messages transmitted from the motherboard 50 to display 28 are prompted by various actions and operations of the various components.

The optical mark reader (OMR) 60 is supported within the housing 12 interior and includes a drive assembly 62 specifically structured to pull the data card through the slot opening and past the optical mark reader 60 for scanning thereof. The OMR 60 is specifically structured to scan and read the data card once pulled therethrough in order to detect and locate darkened areas on the card, including the litho-code, timing marks and darkened (filled-in) bubbles. The OMR sends data corresponding with the readings taken from the data card to the motherboard for storage in the motherboard's memory. This data is thereafter consolidated in the motherboard's memory in accordance with the particular litho code identifying the survey version. Thus, all response data from the scanned data cards is grouped and consolidated for each survey version.

A thermal printer 31 supported within the housing includes a printer memory 32 for storing precreated coupon designs. The specific coupon designs (files) are created using a Visual Basic program on the computer 100 and are subsequently downloaded to the PC-104 motherboard. This data is thereafter transferred to the printer's memory 72. Once the OMR sends the data from the scanned data cards to

the motherboard, indicating that the data card has been completed and inserted in the device, the motherboard 50 activates the thermal printer 31. Upon activation, the thermal printer 31 retrieves one of several stored coupons from the printer's memory 32 and prints the coupon onto thermal paper contained on a roll 34 adjacent the second slot opening. The thermal printer 31 includes means for pulling the paper from the roll 34 to deliver a predetermined length thereof through the coupon slot opening for retrieval by the user.

In order to facilitate downloading of the coupon data and survey files from the computer 100 to the motherboard 50, as well as uploading of data files created in the motherboard memory, the device 10 is provided with a 2400 baud modem 80. The modem 80 facilitates transfer of data between the computer 100 and the motherboard 50 via a telephone line connection 86 or a cellular connection transceiver 88. Alternatively, an RS-232 serial port 84 facilitates direct connection of the computer 100 to the device 10. The consolidated response data, once transferred from the motherboard's memory to the computer 100, is matched with the corresponding labeled file in the remote computer database. The data collected in the labeled file is thereafter used to generate various statistical reports based on responses received from various inquiries of the survey.

Printed reports can also be obtained from the device 10 using a control card having a specific litho code printed along a top of the card. In this instance, the control card is inserted through the first slot opening 24 so that the OMR reads the litho code thereon. The scanned litho code is transmitted to the motherboard 50, commanding the motherboard to consolidate the response data in accordance with a predetermined format, for a specific file or for all survey files (versions 1-12). The motherboard is further commanded to transmit this formatted data to the thermal printer 70 for printing thereof. The resultant report

generated and printed indicates the serial number of the device, the survey version number (1-12) the current date and time, and the total number of responses followed by a row and column number (coordinates) of each bubbled (darkened area) detected by the OMR from each of the scanned data cards inserted by the respondents. Further, the report indicates the total number of each and every bubble that has been recorded as having been darkened. For example, if 56 respondents who have completed and submitted a particular data card for a specific survey (I.e., version 1) have darkened in a bubble located at row 6, column 9 on the data card, then a printed report will show:

Row 6, Column 9 = 56

The report is printed from the thermal printer in order by survey version number (1-12); each page of the report being sequentially numbered. A separate control card is similarly used to delete the data in individual ones of the survey files.

While the instant invention has been shown and described in what is considered to be preferred and practical embodiments thereof, it is recognized that the invention is not to be limited in scope except as set forth in the following claims and within the Doctrine of Equivalents.

Now that the invention has been described,

Claims

1. A method of collecting polling data from respondents comprising the steps of:
  - distributing at least one data card to each of the respondents, the data card being of the type including an array of enclosed areas printed on the card in accordance with a predetermined arrangement and adapted to be completed by the respective respondent by selectively darkening particular ones of the areas in response to a corresponding inquiry,
  - accepting completed ones of said data cards from the respondents,
  - scanning said data cards with an optical mark reader to read polling data by identifying the darkened enclosed areas and other identifying indicia thereon,
  - transmitting said polling data read from each of the data cards to a memory means for storage therein,
  - generating a statistical report based on the collected polling data, and
  - printing said statistical report.
2. A method as recited in claim 1 further including the steps of:
  - reading identification data specific to a particular respondent from a bar code provided on an identification card of the respondent, and
  - transmitting said identification data to said memory means.
3. A method as recited in claim 1 further including the steps of:
  - reading identification data specific to a particular respondent from a magnetic strip provided on an identification card of the respondent, and
  - transmitting said identification data to said memory means.
4. A method of collecting data from respondents comprising the steps of:
  - accepting a substrate from each respondent having

response data thereon,

scanning said substrate with an optical mark reader device to read said response data,

storing said response data in a memory means, and processing said response data to generate a report.

5. A method as recited in claim 4 further including the step of identifying each of the respondents.

6. A method as recited in claim 5 wherein said step of identifying each of the respondents includes scanning an identification card to read respondent specific data and transferring said respondent specific data to said memory means for storage therein.

7. A method as recited in claim 6 wherein said respondent specific data is encoded in a bar code for scanning by a bar code reader.

8. A method as recited in claim 6 wherein said respondent specific data is encoded on a magnetic strip for scanning by a magnetic strip reader.

9. A device for collecting data from a data card of the type including an array of enclosed areas printed on the card in accordance with a predetermined positioning and arrangement thereof, the enclosed areas to be selectively darkened in response to an inquiry, wherein each darkened area represents a response to a corresponding inquiry;

said device comprising:

a housing including a front face, a back panel, a base, and a slot opening in said front face sized and configured for receipt of the data card therethrough,

a central processor unit within an interior of said housing and including control circuit means for controlling operation of said device, and primary memory means for storing data therein,

visual display means on said housing for displaying information including instructional information relating to use and operation of said device, and

an optical mark reader positioned and disposed within said interior of said housing in communication with said

slot opening and structured to scan and read said data card to identify the darkened enclosed areas thereon and transmit response data to said central processor unit corresponding with the location of said identified darkened area within said array relative to a fixed reference on said data card, said response data being stored in said primary memory means.

10. A device as recited in claim 9 further including a magnetic strip reader interconnected to said central processor unit and structured and disposed to read data encoded on a magnetic strip.

11. A device as recited in claim 10 wherein said magnetic strip reader is structured and disposed to facilitate passage of a substrate through a slot thereof, wherein the substrate includes a magnetic strip thereon.

12. A device as recited in claim 9 further including a bar code reader interconnected to said central processor unit and structured and disposed to scan a bar code and transmit scanned data obtained from said bar code for storage in said central processor unit.

13. A device for collecting data from a data card of the type including an array of enclosed areas printed on the card in accordance with a predetermined positioning and arrangement thereof, the enclosed areas to be selectively darkened in response to an inquiry;

said device comprising:

a housing including a front face, a back panel, a base, a first slot opening in said front face sized and configured for receipt of the data card therethrough and a second slot opening sized and configured for dispensing a predetermined length of a paper strip therefrom;

a central processor unit within an interior of said housing and including control circuit means for controlling operation of said device, and primary memory means for storing data therein,

visual display means on said housing for displaying information including instructional information relating to



use and operation of said device,

an optical mark reader positioned and disposed within said interior of said housing in communication with said first slot opening and structured to scan and read said data card to identify the darkened enclosed areas thereon and transmit response data to said central processor unit corresponding with the location of each identified darkened area within said array relative to a fixed reference on said data card, said response data being stored in said primary memory means, and

printer means supported within said housing interior and including a printer memory means, said printer means being actuated by said central processor unit to print indicia on said paper strip corresponding with stored data in said printer memory means, and said printer means being further structured to dispense a select length of said paper strip through said second slot for retrieval by a user of said device.

14. A device as recited in claim 13 wherein said optical mark reader includes drive means for engaging and pulling said data card through said first slot opening for scanning thereof.

15. A method of collecting data from respondents using the device as recited in claim 13, comprising the steps of:

creating one or more questionnaires, including said data card, using a visual basic computer program, and storing said questionnaire in one a plurality of labeled files in said remote computer database, said questionnaire having one or more inquiries requiring a response, and wherein each of said enclosed areas on said data card corresponds to a select answer to said one or more inquiries of said questionnaire,

assigning an identification code to said created questionnaire, the identification code corresponding to the labeled file in which said questionnaire is stored,

printing a master copy of said questionnaire including said identification code printed thereon,

making a select number of duplicate copies of said questionnaire from said master copy,

distributing said duplicate copies of said questionnaire to the respondents, wherein the respondents respond to the inquiries by darkening select ones of said enclosed areas on said data card, thereby completing said data card,

accepting completed data cards individually from the respondents through said first slot opening of said device,

scanning said data cards with said optical mark reader to identify the darkened enclosed areas and the assigned identification code thereon,

transmitting said response data relating to the identified darkened enclosed areas and assigned identification code from said optical card reader to said primary memory means for storage therein,

consolidating said response data from said scanned data cards in accordance with said identification code.

transmitting said consolidated response data to said remote computer database,

matching said consolidated response data with the corresponding labeled file in said remote computer database, and

generating a statistical report for each of said labeled files based on a comparison of said consolidated response data with said inquiries of said questionnaire.

16. A method as recited in claim 15 further including the step of printing said generated statistical reports.

17. A method as recited in claim 15 further including the steps:

creating a coupon using the visual basic computer program, and storing said created coupon in a coupon data file in said remote computer database,

transmitting said coupon data file to said central processor unit of said device for storage therein,

transmitting said coupon data file from said central processor unit to said printer memory means,

printing said created coupon on said paper strip upon actuation of said printer means by said central processor unit, and

dispensing said paper strip with said created coupon printed thereon from said second slot opening of said device.

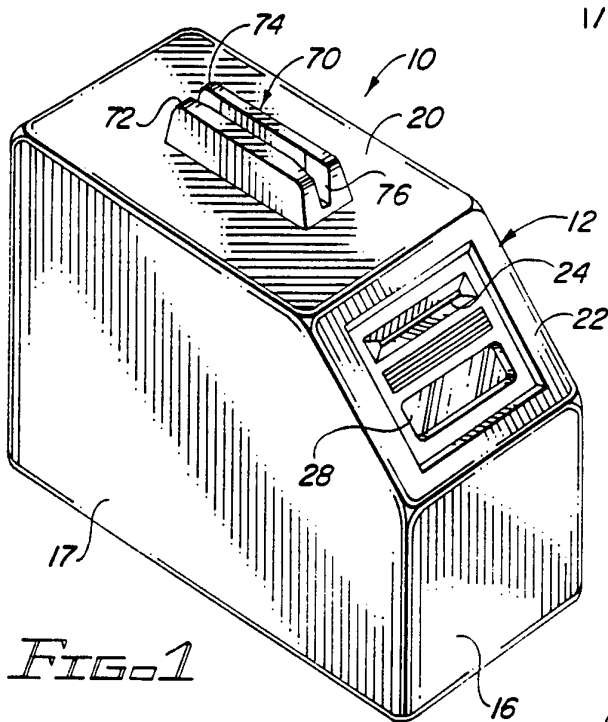

FIG. 1

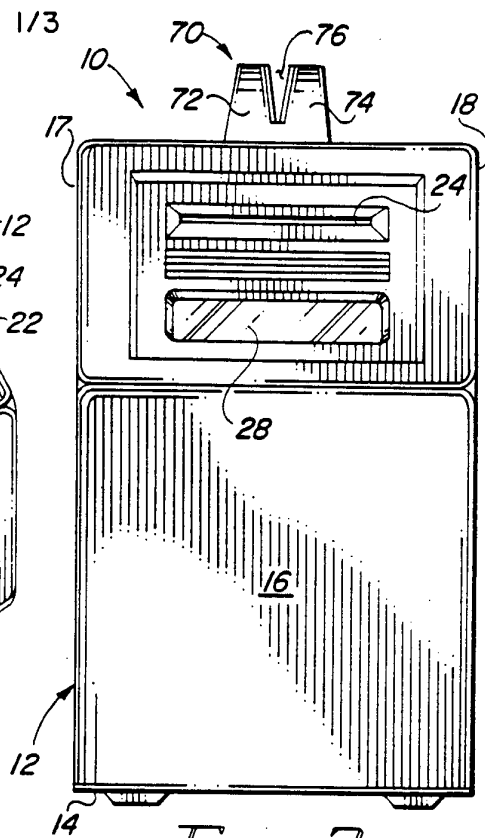

FIG. 2

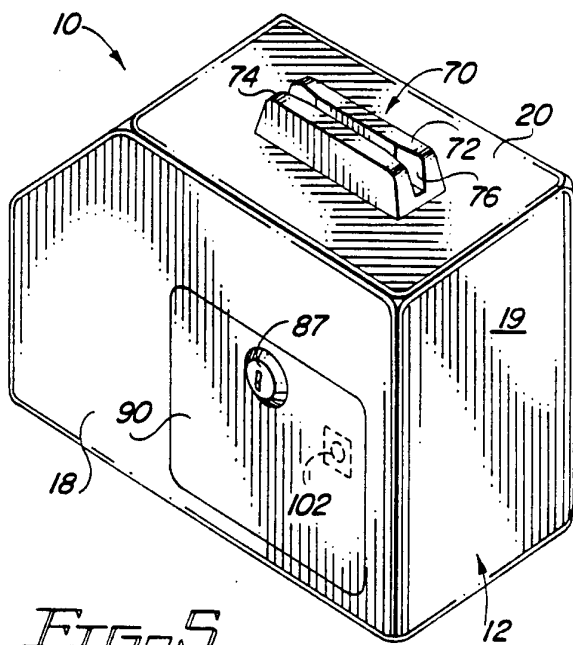

FIG. 5

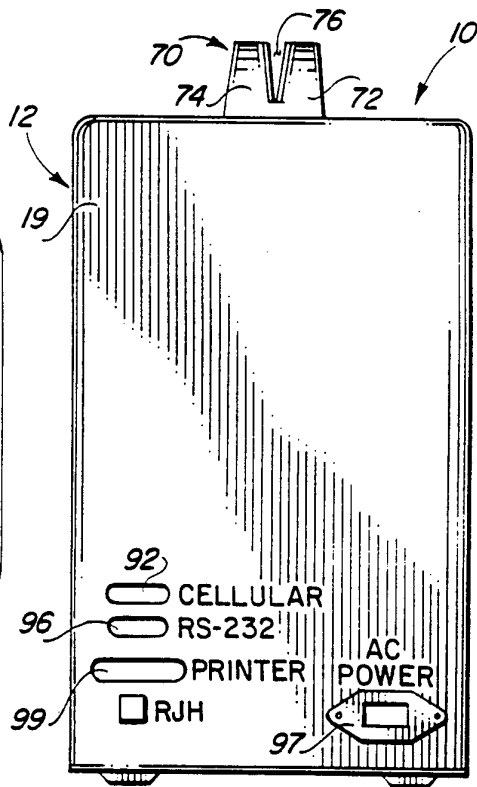

FIG. 4

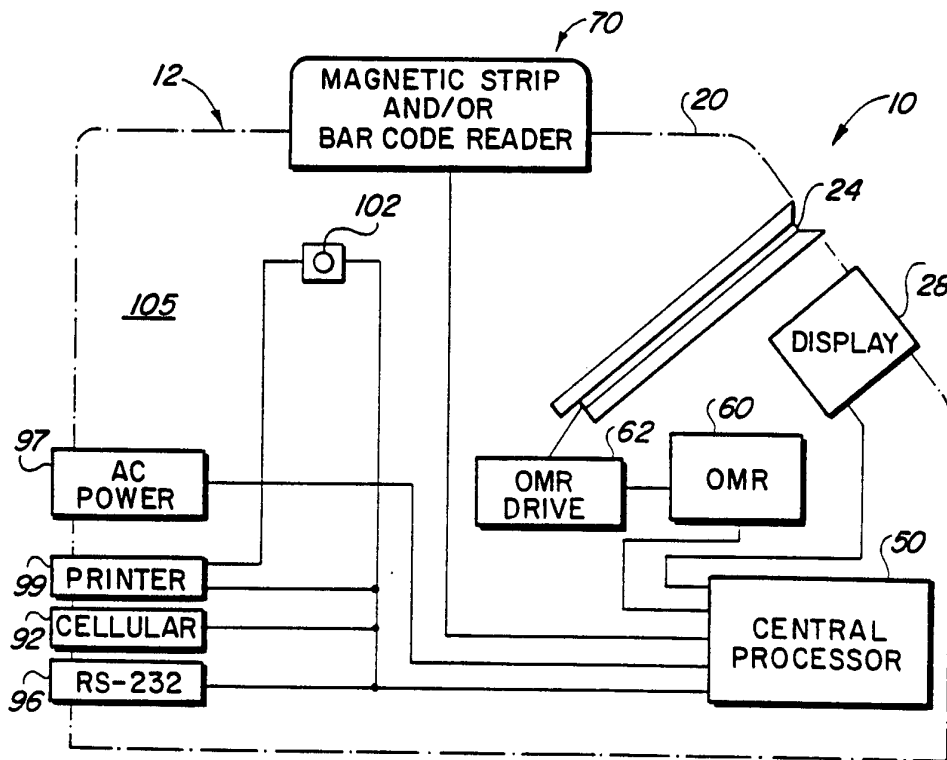

FIG. 3

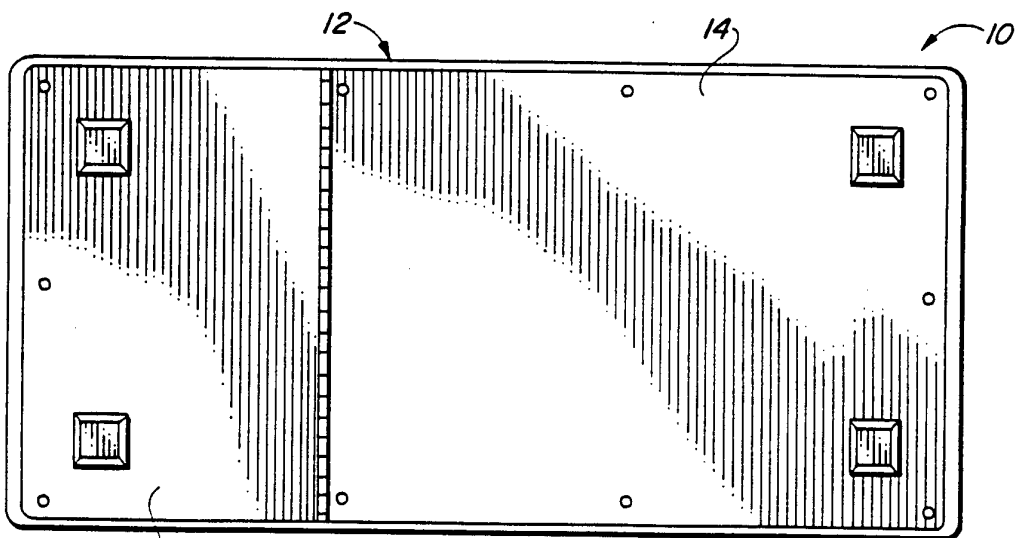

FIG. 6

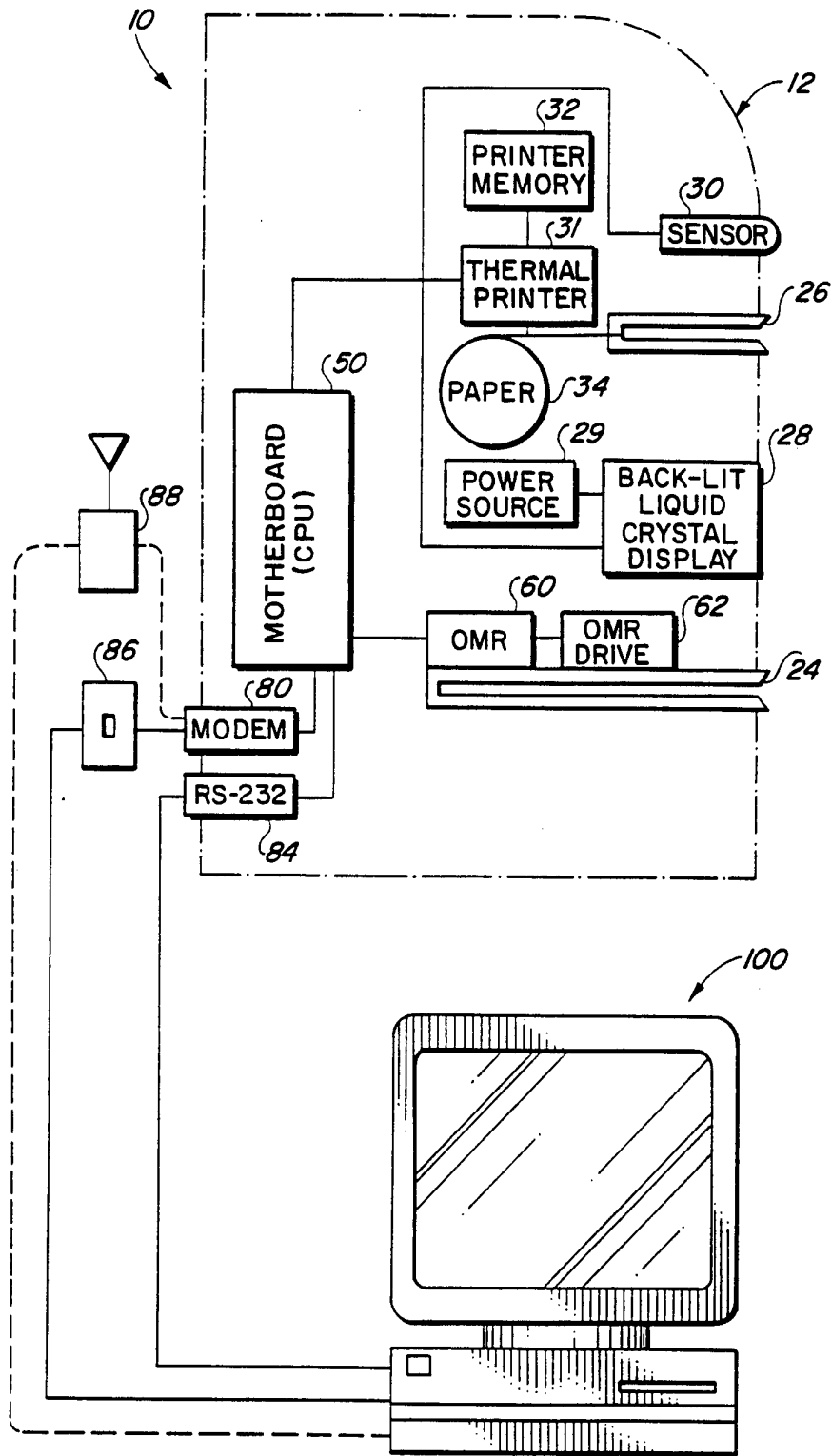

FIG. 7

INTERNATIONAL SEARCH REPORT

International application No.  
PCT/US95/12297

**A. CLASSIFICATION OF SUBJECT MATTER**

IPC(6) :G06F 17/60

US CL :235/386, 440, 454, 449, 375; 364/408, 409

According to International Patent Classification (IPC) or to both national classification and IPC

**B. FIELDS SEARCHED**

Minimum documentation searched (classification system followed by classification symbols)

U.S. : 235/386, 440, 454, 449, 375; 364/408, 409

Documentation searched other than minimum documentation to the extent that such documents are included in the fields searched

Electronic data base consulted during the international search (name of data base and, where practicable, search terms used)

Please See Extra Sheet.

**C. DOCUMENTS CONSIDERED TO BE RELEVANT**

Category*	Citation of document, with indication, where appropriate, of the relevant passages	Relevant to claim No.
X	US, A, 4,774,665 (WEBB) 27 September 1988, whole document	1, 4, 9, and 13-14
Y	US, A, 4,774,665 (WEBB) 27 September 1988, whole document	15-17
Y	FR, A, 2,659,465 (MACAIGNE ALAIN) 13 September 1991, whole document	2, 5-7, and 12
Y	US, A, 4,373,134 (GRACE ET AL) 08 February 1983, whole document	3, 8, and 10-11
Y	US, A, 5,023,435 (DENIGER) 11 June 1991, whole document	2, 5-7, and 12
Y	US, A, 4,396,902 (WARTHAN ET AL) 02 August 1983, whole document	3, 8, and 10-11

Further documents are listed in the continuation of Box C.  See patent family annex.

* Special categories of cited documents:	"T" later document published after the international filing date or priority date and not in conflict with the application but cited to understand the principle or theory underlying the invention
"A" document defining the general state of the art which is not considered to be of particular relevance	"X" document of particular relevance; the claimed invention cannot be considered novel or cannot be considered to involve an inventive step when the document is taken alone
"E" earlier document published on or after the international filing date	"Y" document of particular relevance; the claimed invention cannot be considered to involve an inventive step when the document is combined with one or more other such documents, such combination being obvious to a person skilled in the art
"L" document which may throw doubts on priority claim(s) or which is cited to establish the publication date of another citation or other special reason (as specified)	"&" document member of the same patent family
"O" document referring to an oral disclosure, use, exhibition or other means	
"P" document published prior to the international filing date but later than the priority date claimed	

Date of the actual completion of the international search

17 NOVEMBER 1995

Date of mailing of the international search report

03 JAN 1996

Name and mailing address of the ISA/US  
Commissioner of Patents and Trademarks  
Box PCT  
Washington, D.C. 20231

Facsimile No. (703) 305-3230

Authorized officer

MICHAEL G. LEE

Telephone No. (703) 305-3503

## INTERNATIONAL SEARCH REPORT

International application No.  
PCT/US95/12297

C (Continuation). DOCUMENTS CONSIDERED TO BE RELEVANT		
Category*	Citation of document, with indication, where appropriate, of the relevant passages	Relevant to claim No.
Y	US, A, 3,761,683 (ROGERS) 25 September 1973, whole document	2-3, 5-8, and 10-12
Y	US, A, 5,084,819 (DEWEY ET AL) 28 January 1992, whole document	1, 4, 9, and 13
Y	JP, A, 2-251497(A) (TAKIGUCHI) 09 October 1990, whole document	2-3, 5-8, and 10-12
Y	JP, A, 4-340183(A) (KATO) 26 November 1992, whole document	3, 8, and 10-11



INTERNATIONAL SEARCH REPORT

International application No.  
PCT/US95/12297

**B. FIELDS SEARCHED**

Electronic data bases consulted (Name of data base and where practicable terms used):

**APS:**

search terms: (device or apparatus or system or machine), (slot or opening or access), scann? and read?, processor and memory and display, magnetic strip? and bar code and indicia, card or substrate, (tally? or poll? or ballot?), printer, survey, (identification or verification)