



US00D734723S

(12) **United States Design Patent**  
**Scholeno**

(10) **Patent No.:** **US D734,723 S**

(45) **Date of Patent:** **\*\* Jul. 21, 2015**

(54) **HOUSING FOR ELECTRICAL CONNECTOR**

(71) Applicant: **Michael Scholeno**, York, PA (US)

(72) Inventor: **Michael Scholeno**, York, PA (US)

(73) Assignee: **FCI AMERICAS TECHNOLOGY LLC**, Carson City, NV (US)

(\*\*) Term: **14 Years**

(21) Appl. No.: **29/484,625**

(22) Filed: **Mar. 11, 2014**

(51) **LOC (10) Cl.** ..... **13-03**

(52) **U.S. Cl.**  
USPC ..... **D13/133**

(58) **Field of Classification Search**  
USPC ..... D13/110, 123, 133, 146, 147, 154-15,  
D13/184, 196; D14/443  
CPC ..... H01P 5/00; H01R 12/70; H01R 13/66;  
H01R 33/00; H01R 24/00; H01R 25/00;  
H01R 27/00; H01R 29/00; H01R 13/20;  
H01R 31/06; H01B 1/10  
See application file for complete search history.

(56) **References Cited**

**U.S. PATENT DOCUMENTS**

D446,501	S	*	8/2001	Donnell et al.	.....	D13/133
D454,333	S	*	3/2002	Ikeda et al.	.....	D13/133
D676,385	S	*	2/2013	Gassauer	.....	D13/133
D676,386	S	*	2/2013	Gassauer	.....	D13/133
D684,118	S	*	6/2013	Yang et al.	.....	D13/133
D689,821	S	*	9/2013	Yang et al.	.....	D13/133
D701,491	S	*	3/2014	Miyoshi	.....	D13/147
2013/0017711	A1		1/2013	Houtz		
2014/0302710	A1	*	10/2014	Tada et al.	.....	439/527

\* cited by examiner

*Primary Examiner* — Thomas Johannes

*Assistant Examiner* — Shawn T Gingrich

(74) *Attorney, Agent, or Firm* — Baker & Hostetler LLP

(57) **CLAIM**

The ornamental design for a housing for an electrical connector, as shown and described.

**DESCRIPTION**

FIG. 1 is a top, left, front perspective view of a housing for an electrical connector according to the first embodiment of my design;

FIG. 2 is a bottom, right, front perspective view thereof;

FIG. 3 is a top, left, rear perspective view thereof;

FIG. 4 is a top, right, front perspective view thereof;

FIG. 5 is a bottom, left, front perspective view thereof;

FIG. 6 is a front elevation view thereof;

FIG. 7 is a rear elevation view thereof;

FIG. 8 is a right side elevation view thereof;

FIG. 9 is a left side elevation view thereof;

FIG. 10 is a top plan view thereof;

FIG. 11 is a bottom plan view thereof;

FIG. 12 is a top, left, front perspective view of a housing for an electrical connector according to the second embodiment of my design;

FIG. 13 is a bottom, right, front perspective view thereof;

FIG. 14 is a top, left, rear perspective view thereof;

FIG. 15 is a top, right, front perspective view thereof;

FIG. 16 is a bottom, left, front perspective view thereof;

FIG. 17 is a front elevation view thereof;

FIG. 18 is a rear elevation view thereof;

FIG. 19 is a right side elevation view thereof;

FIG. 20 is a left side elevation view thereof;

FIG. 21 is a top plan view thereof;

FIG. 22 is a bottom plan view thereof;

FIG. 23 is a top, left, front perspective view of a housing for an electrical connector according to the third embodiment of my design;

FIG. 24 is a bottom, right, front perspective view thereof;

FIG. 25 is a top, left, rear perspective view thereof;

FIG. 26 is a top, right, front perspective view thereof;

FIG. 27 is a bottom, left, front perspective view thereof;

FIG. 28 is a front elevation view thereof;

FIG. 29 is a rear elevation view thereof;

FIG. 30 is a right side elevation view thereof;

FIG. 31 is a left side elevation view thereof;

FIG. 32 is a top plan view thereof;

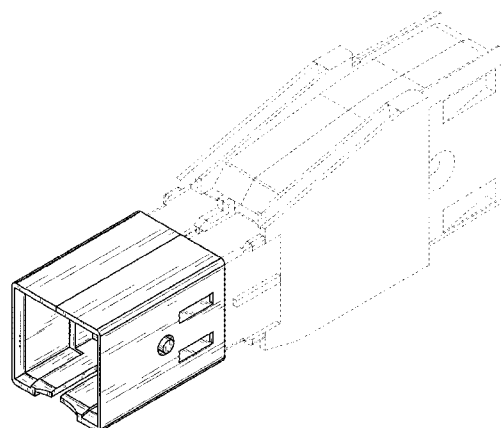
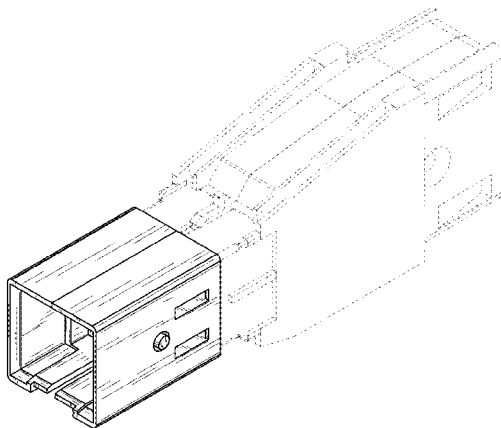

FIG. 33 is a bottom plan view thereof;  
FIG. 34 is a top, left, front perspective view of a housing for an electrical connector according to the fourth embodiment of my design;  
FIG. 35 is a bottom, right, front perspective view thereof;  
FIG. 36 is a top, left, rear perspective view thereof;  
FIG. 37 is a top, right, front perspective view thereof;  
FIG. 38 is a bottom, left, front perspective view thereof;  
FIG. 39 is a front elevation view thereof;  
FIG. 40 is a rear elevation view thereof;  
FIG. 41 is a right side elevation view thereof;  
FIG. 42 is a left side elevation view thereof;  
FIG. 43 is a top plan view thereof;  
FIG. 44 is a bottom plan view thereof;  
FIG. 45 is a top, left, front perspective view of a housing for an electrical connector according to the fifth embodiment of my design;  
FIG. 46 is a bottom, right, front perspective view thereof;

FIG. 47 is a top, left, rear perspective view thereof;  
FIG. 48 is a top, right, front perspective view thereof;  
FIG. 49 is a bottom, left, front perspective view thereof;  
FIG. 50 is a front elevation view thereof;  
FIG. 51 is a rear elevation view thereof;  
FIG. 52 is a right side elevation view thereof;  
FIG. 53 is a left side elevation view thereof;  
FIG. 54 is a top plan view thereof; and,  
FIG. 55 is a bottom plan view thereof.  
FIGS. 4-7, 15-18, 26-29, 37-40, and 48-51 are shown in an enlarged scale for illustrative clarity.  
The broken line portion of the figure drawings is included to show unclaimed subject matter only for the purpose of illustrating environment and forms no part of the claimed design.  
The nature of this product is an electrically insulative housing for an electrical connector.

**1 Claim, 25 Drawing Sheets**

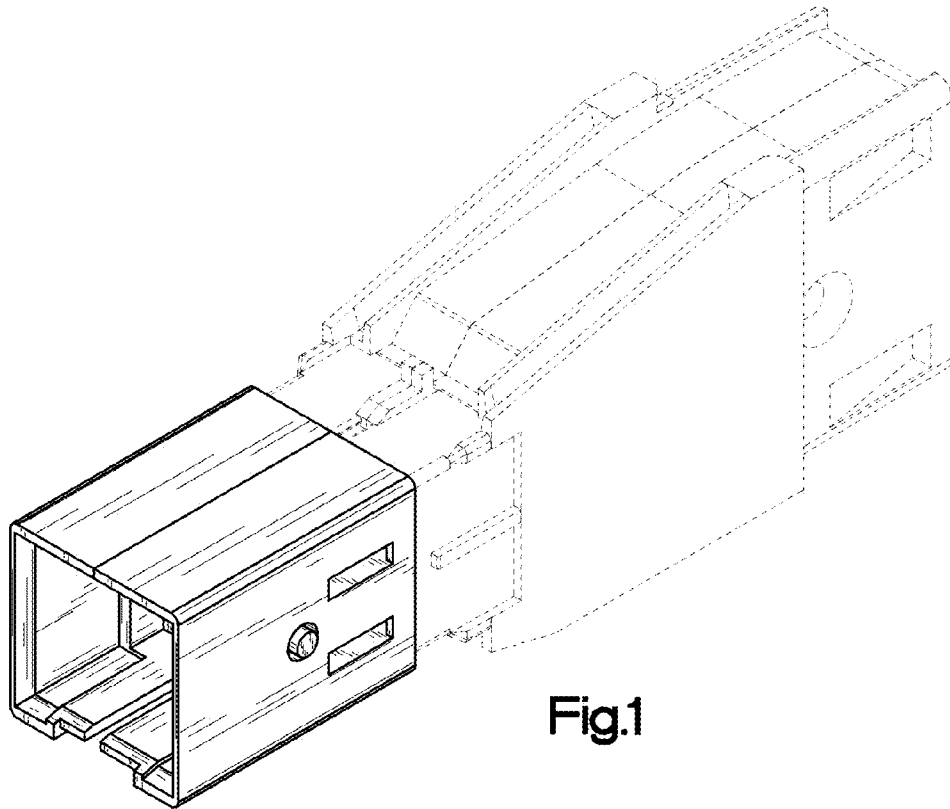

Fig.1

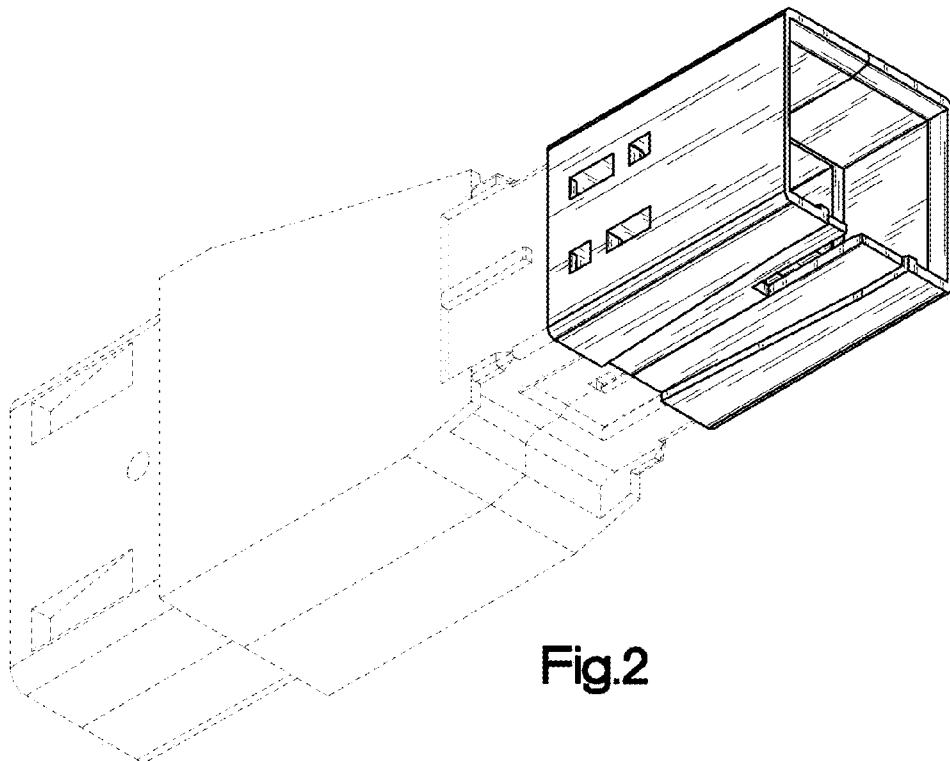

Fig.2

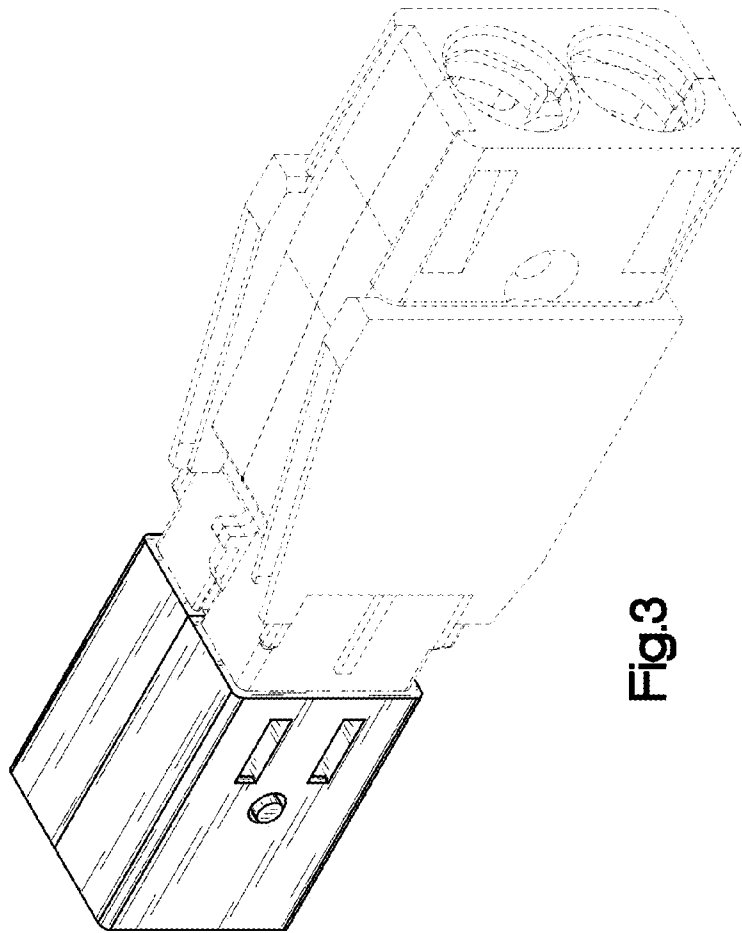

Fig.3

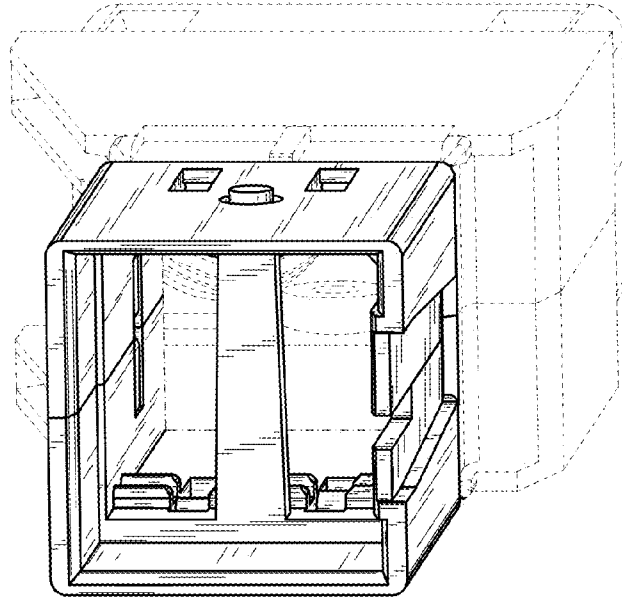

Fig.5

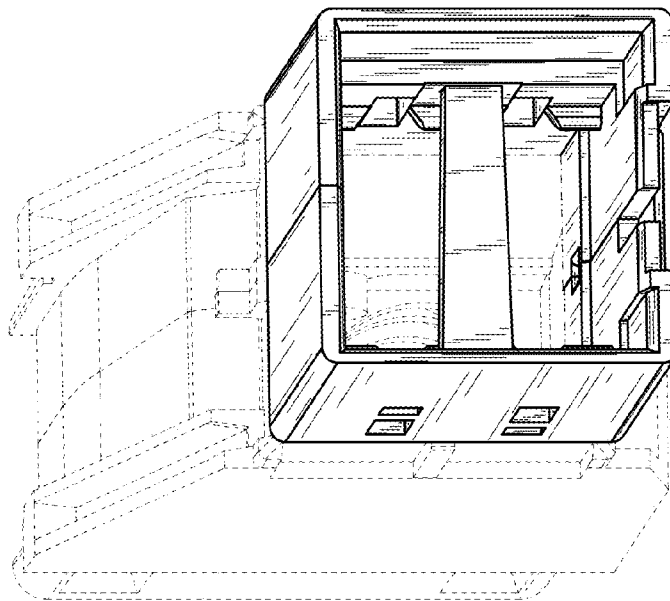

Fig.4

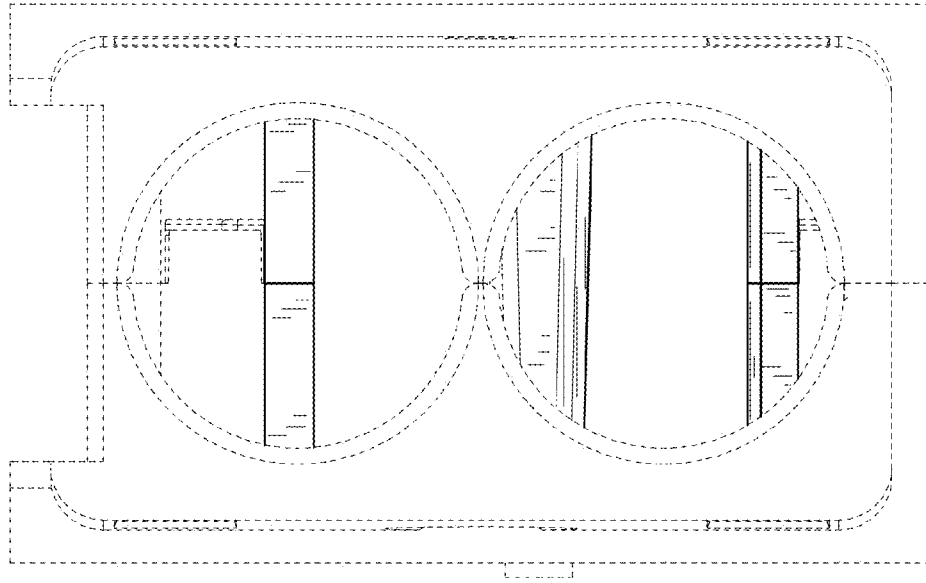

Fig.7

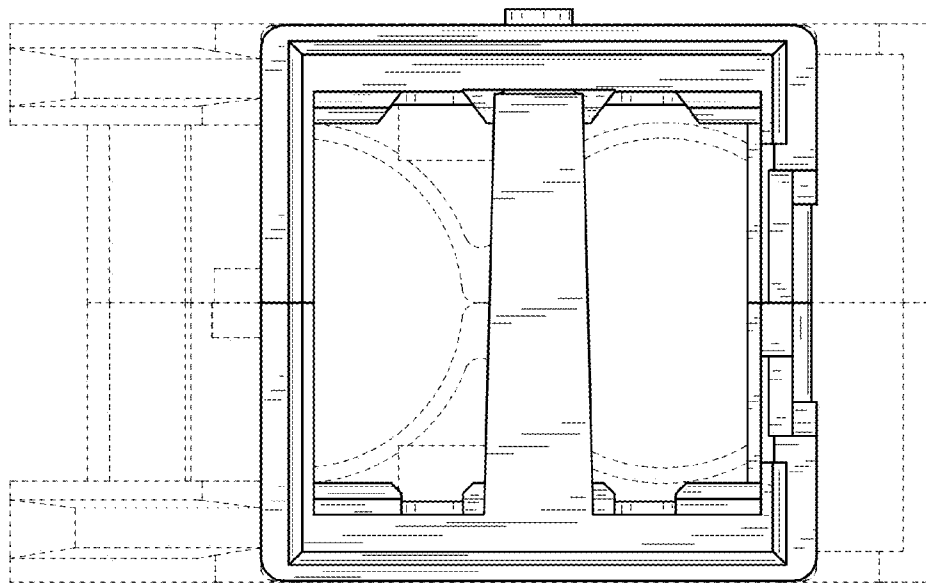

Fig.6

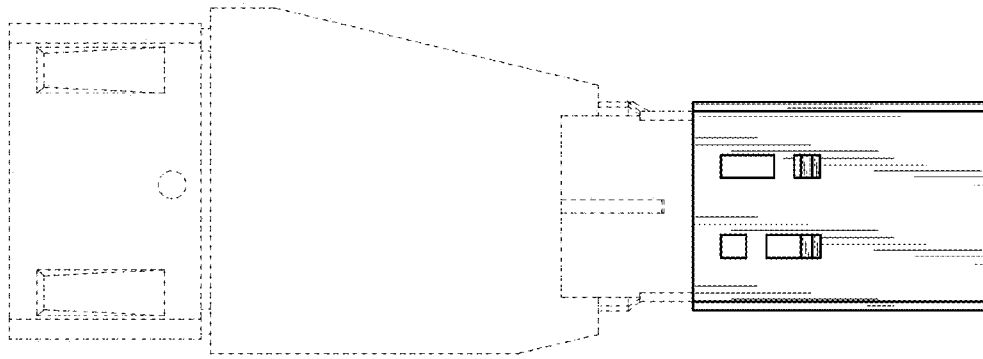

Fig.8

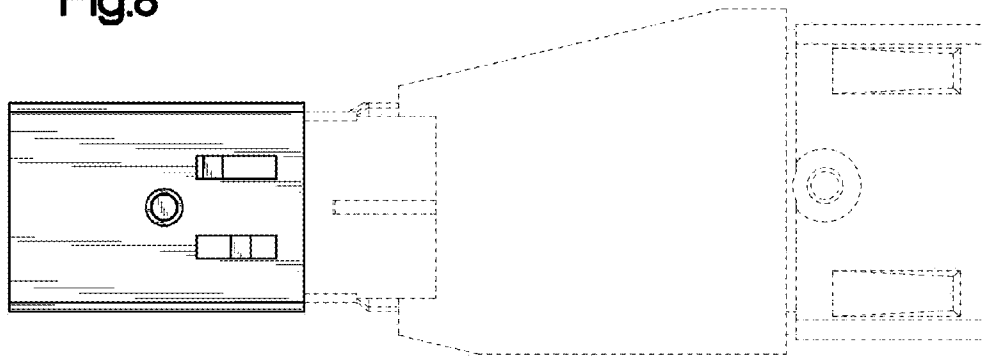

Fig.9

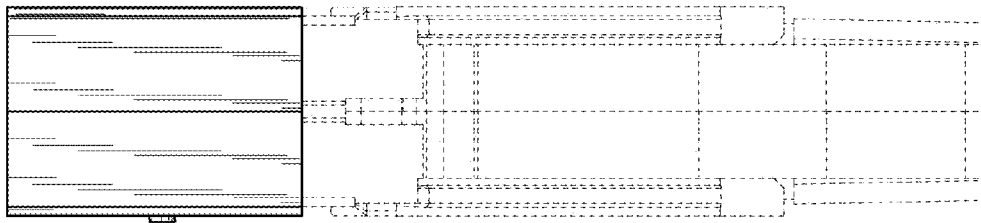

Fig.10

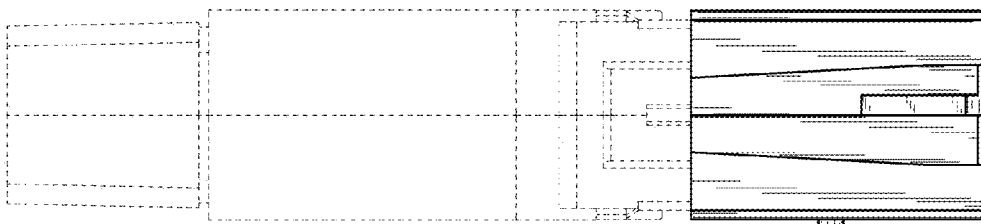

Fig.11

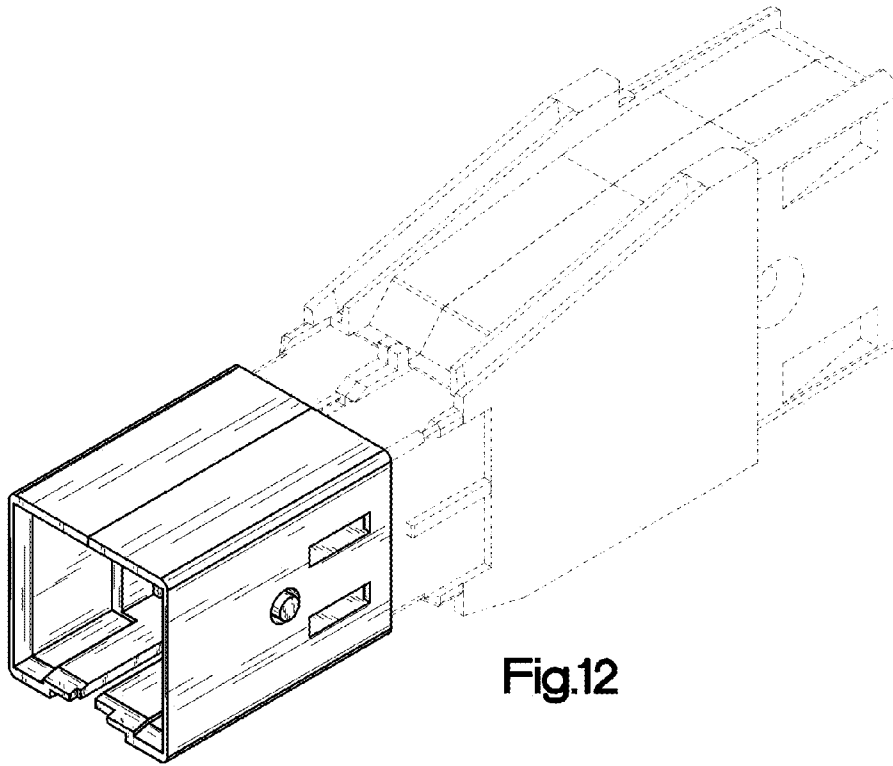

Fig.12

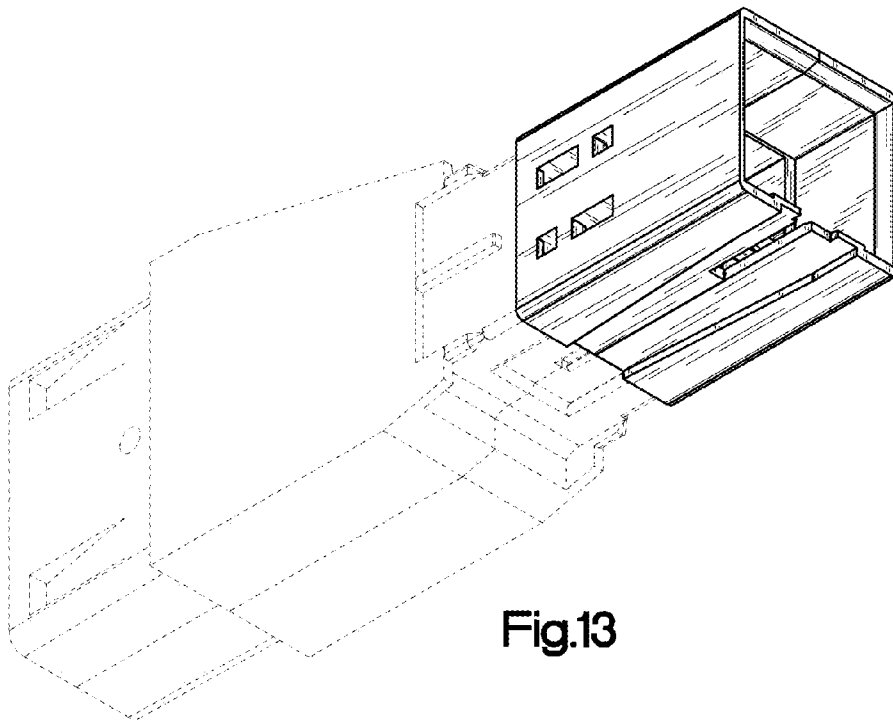

Fig.13

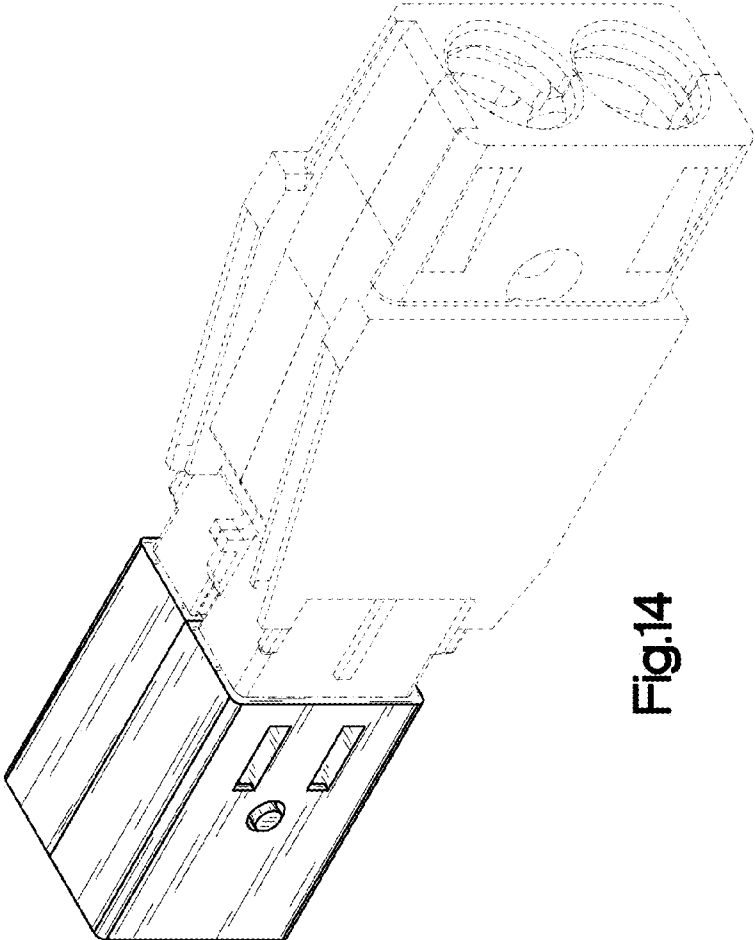

Fig.14

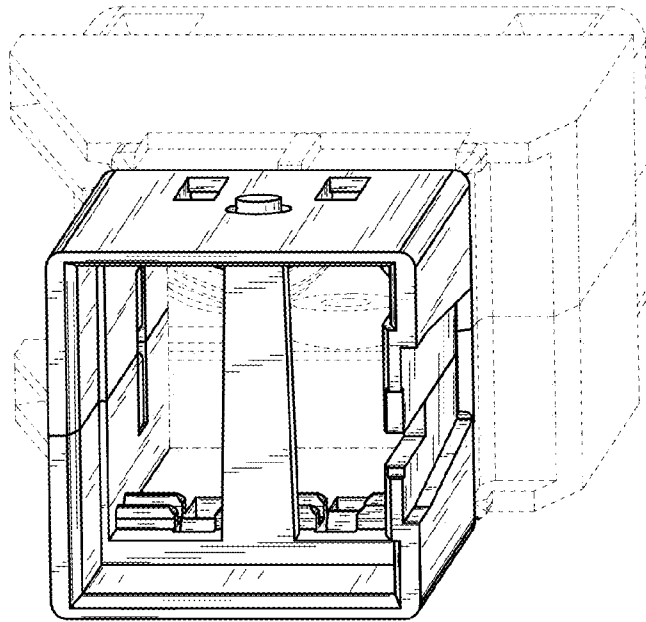

Fig.16

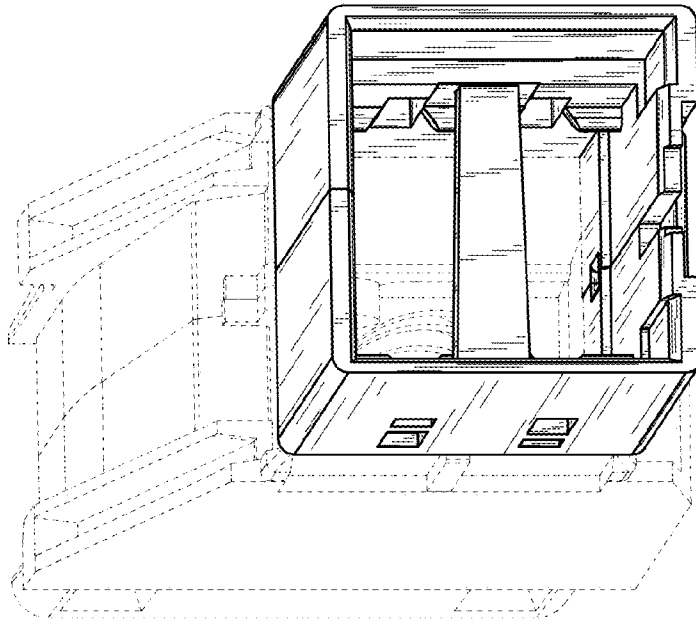

Fig.15

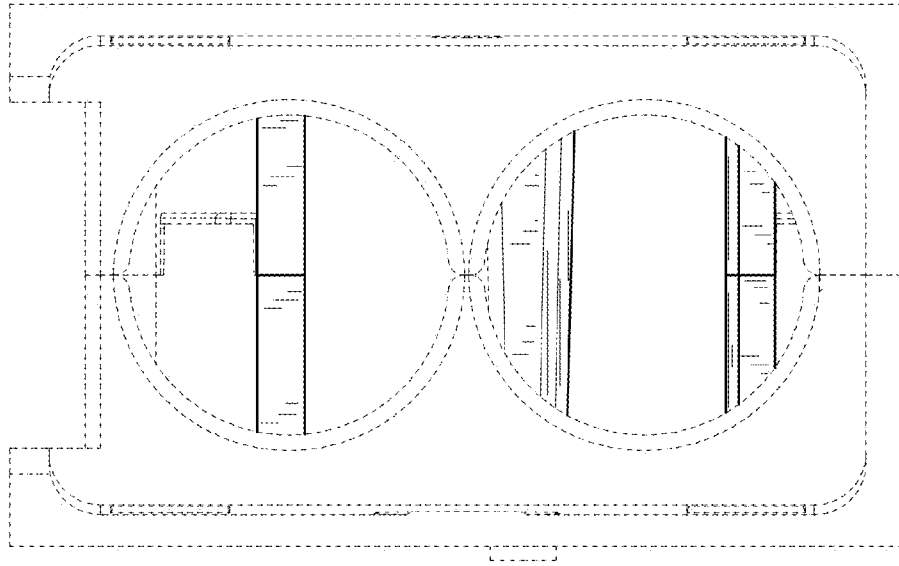

Fig.18

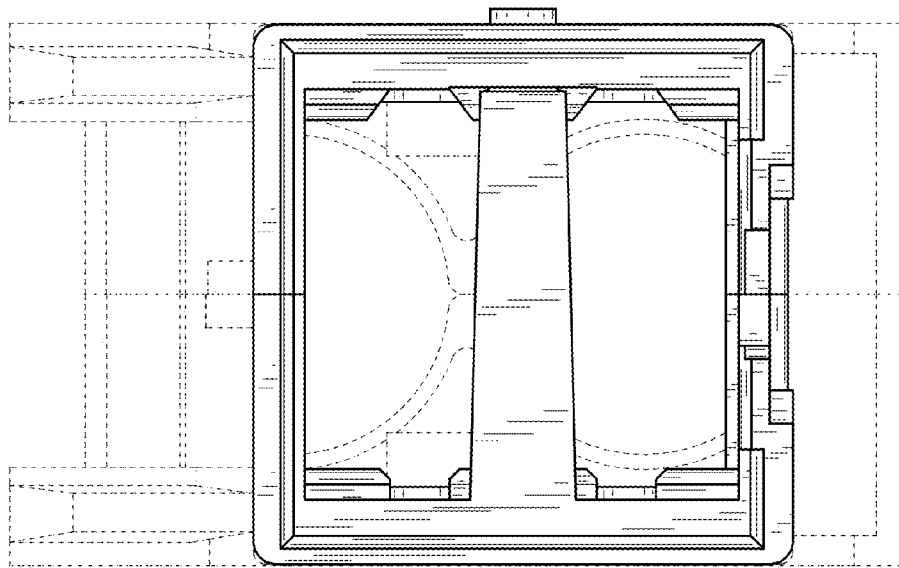

Fig.17

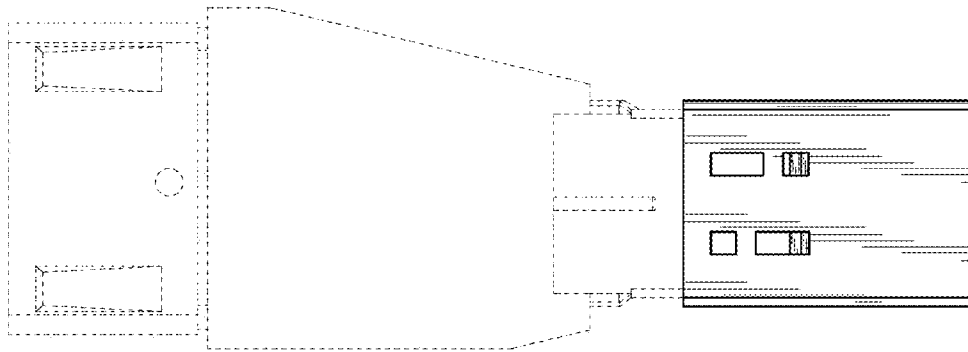

Fig.19

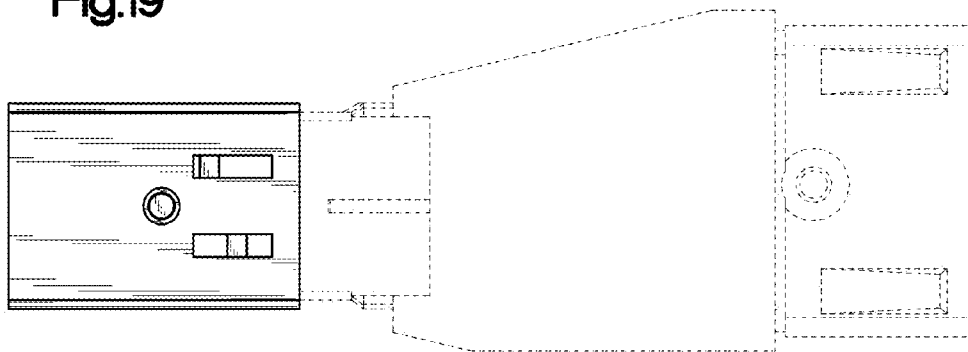

Fig.20

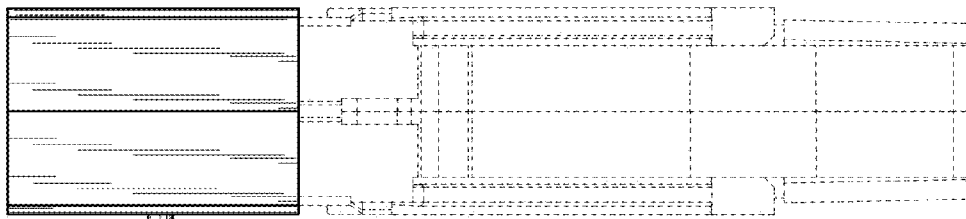

Fig.21

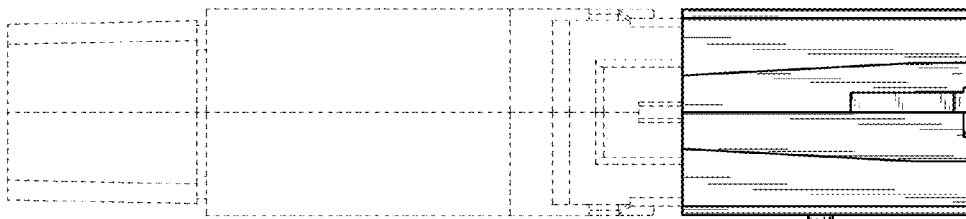

Fig.22

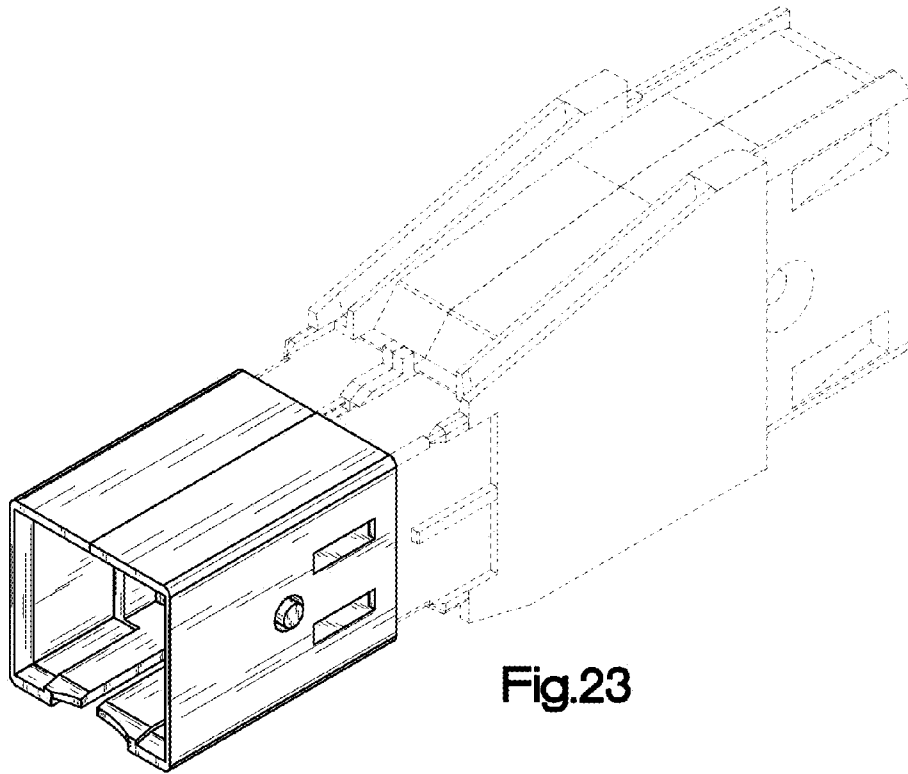

Fig.23

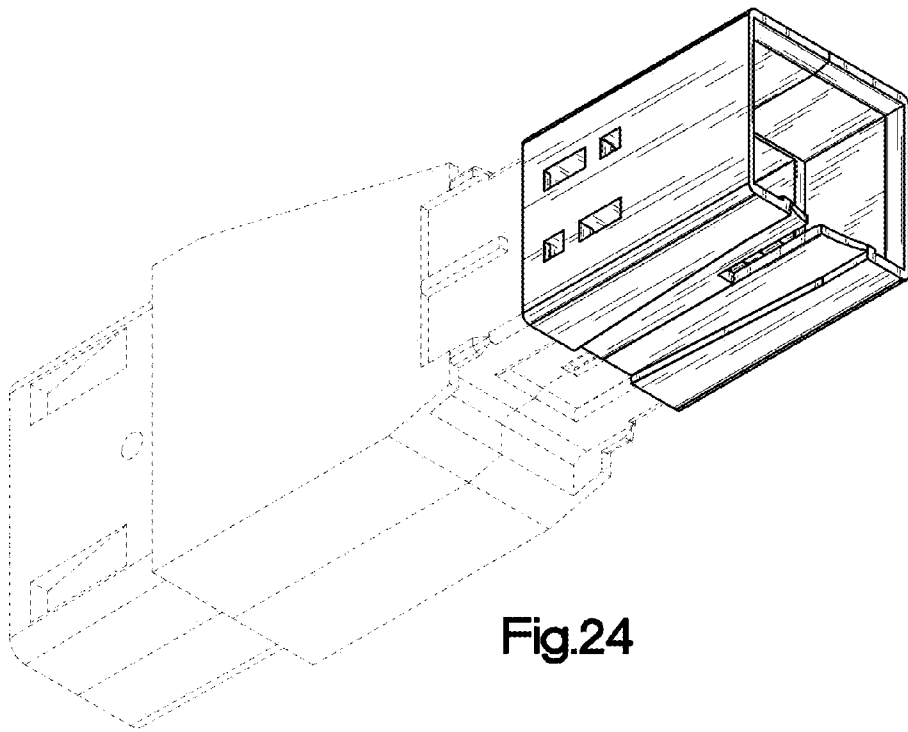

Fig.24

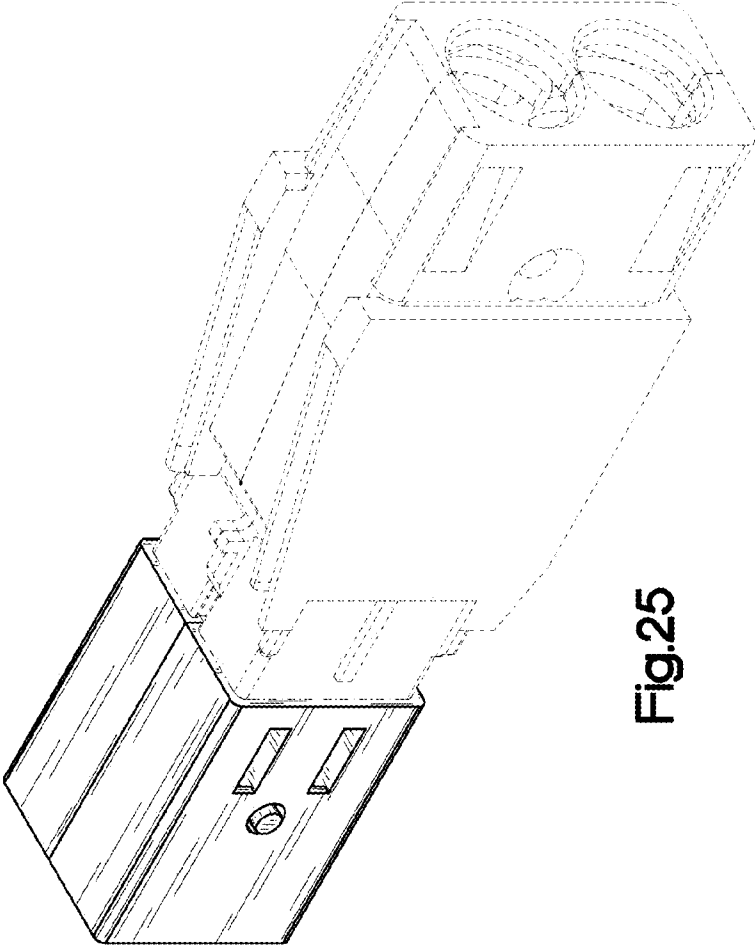

Fig.25

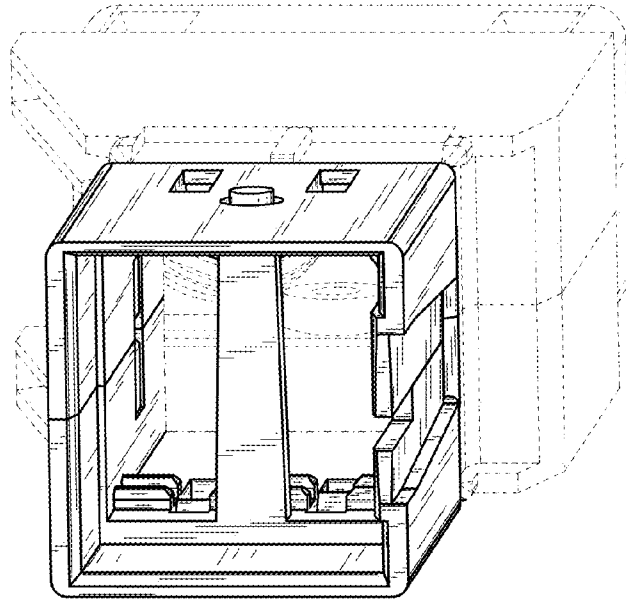

Fig.27

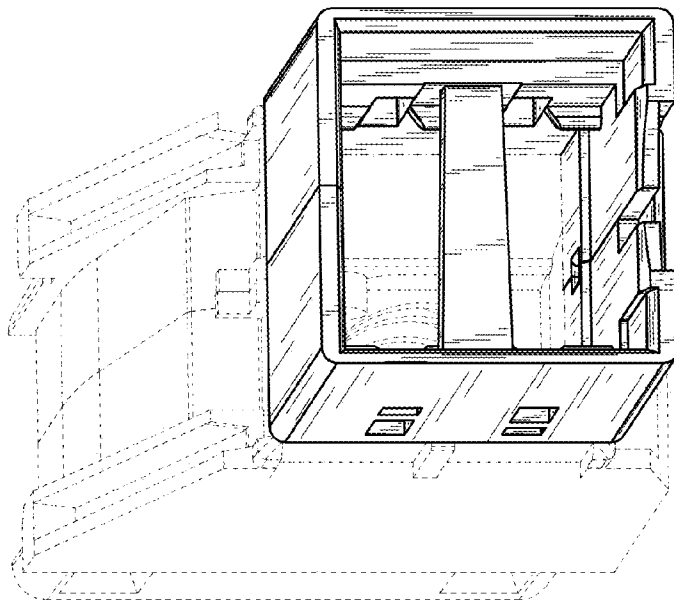

Fig.26

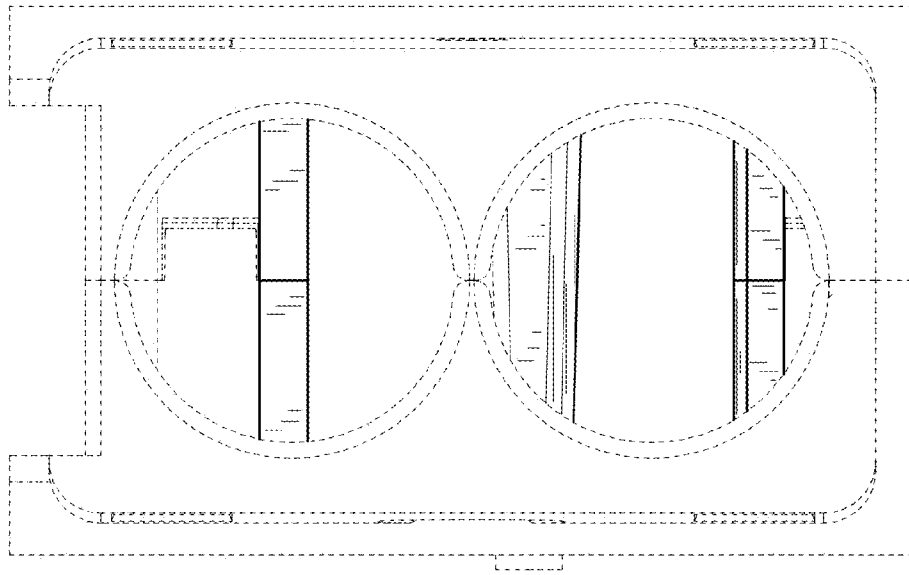

Fig.29

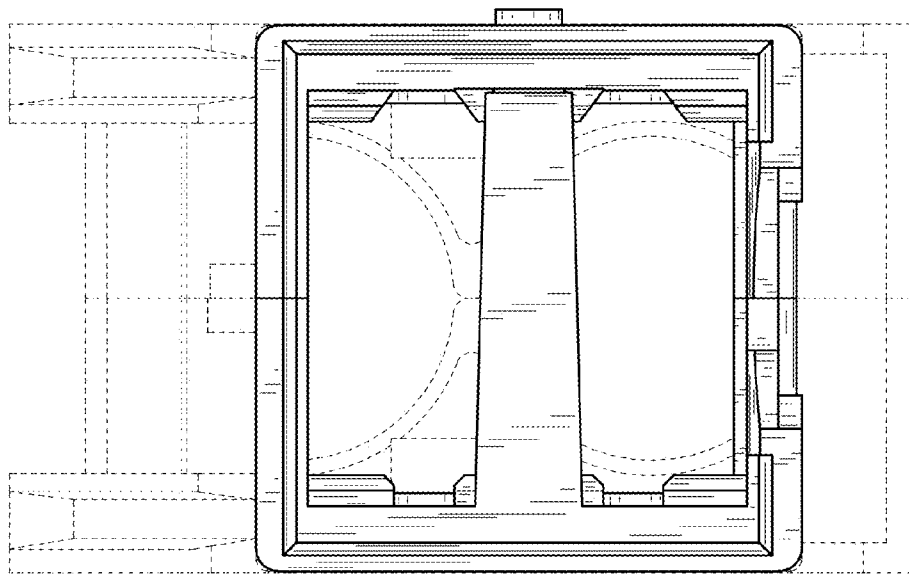

Fig.28

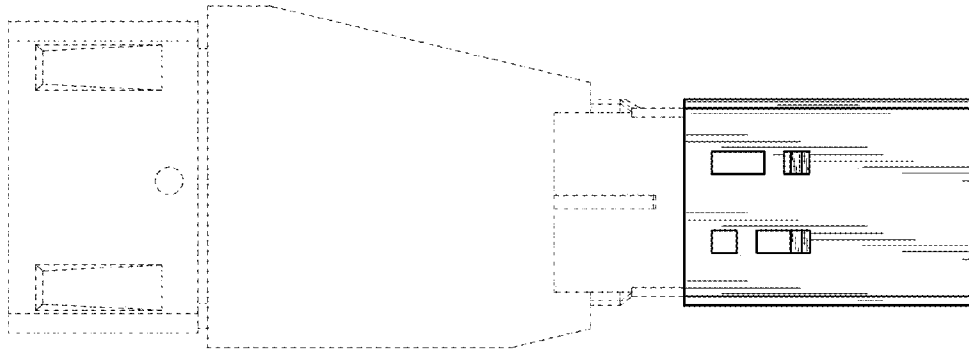

Fig.30

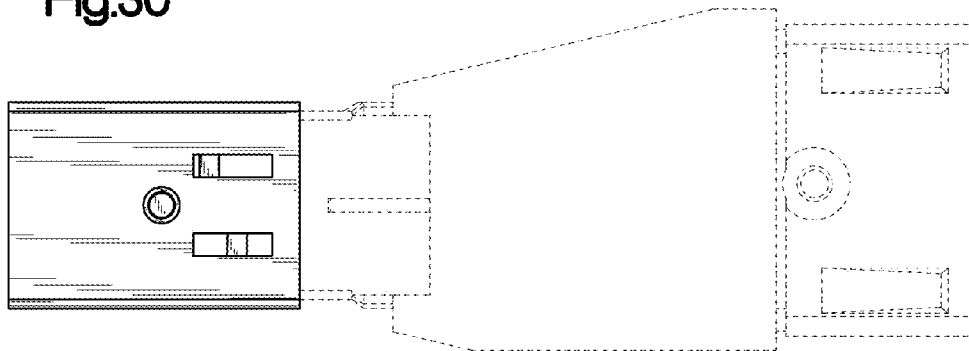

Fig.31

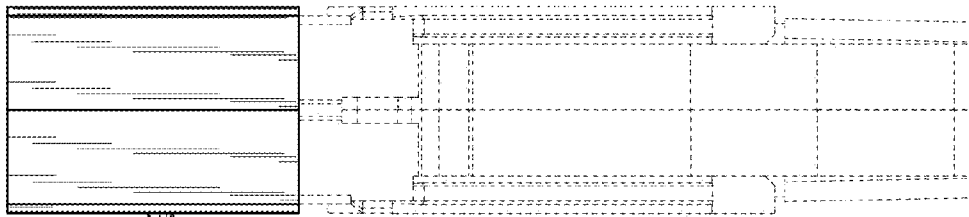

Fig.32

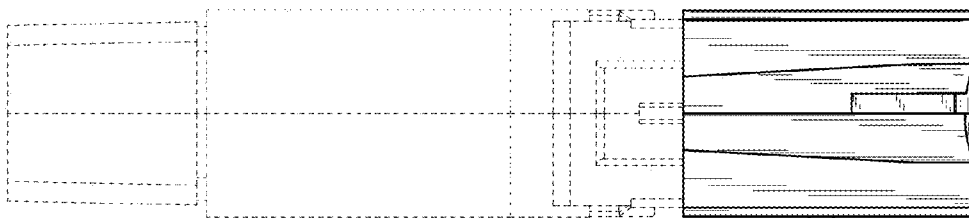

Fig.33

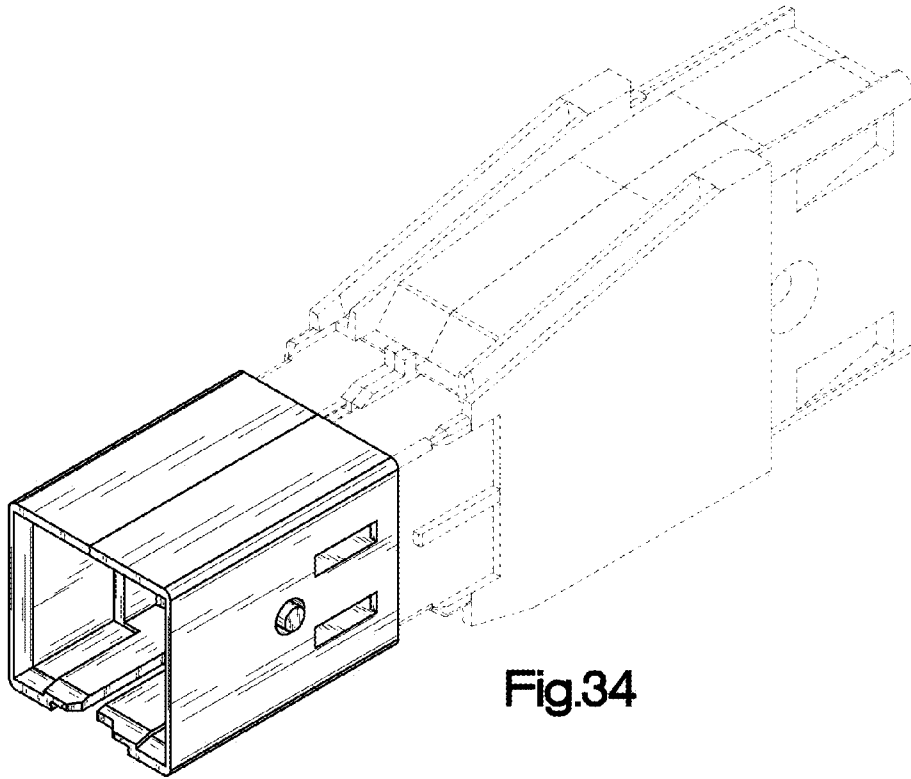

Fig.34

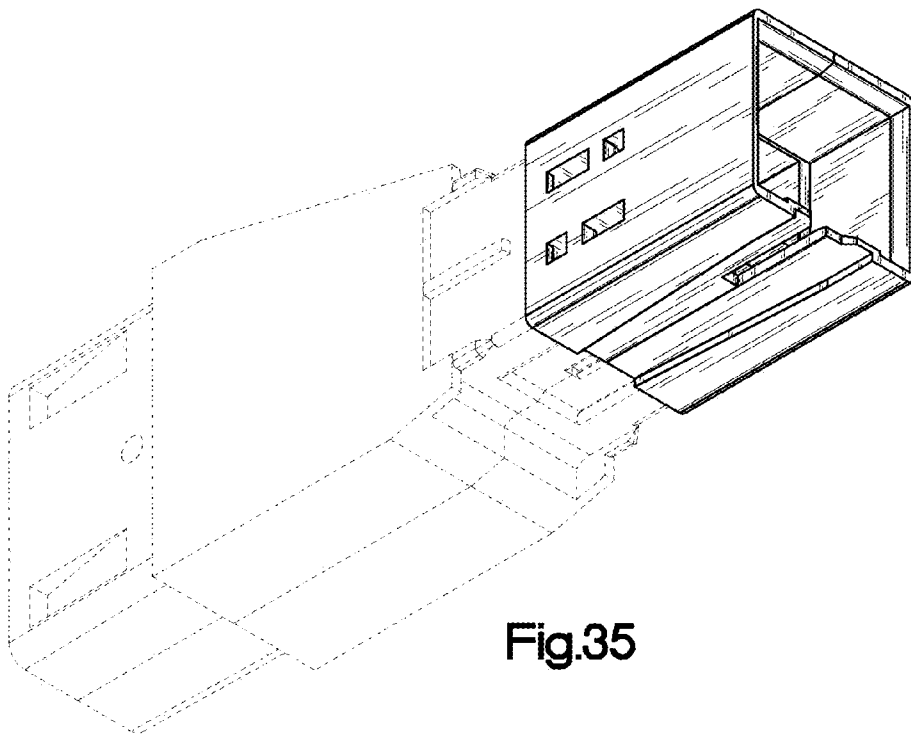

Fig.35

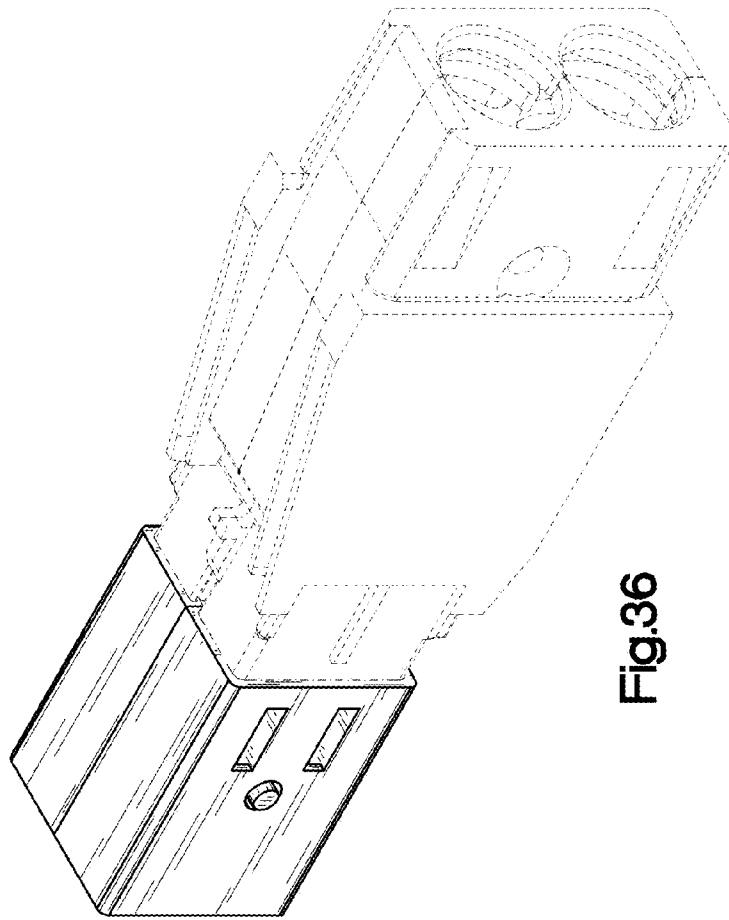

Fig.36

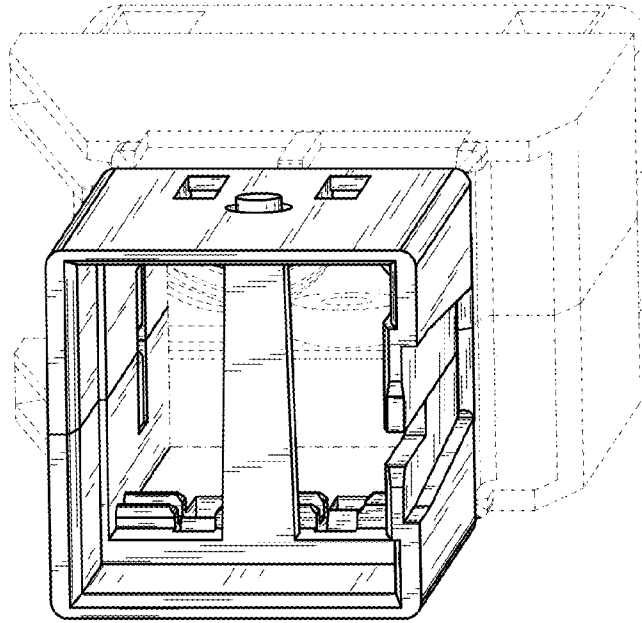

Fig.38

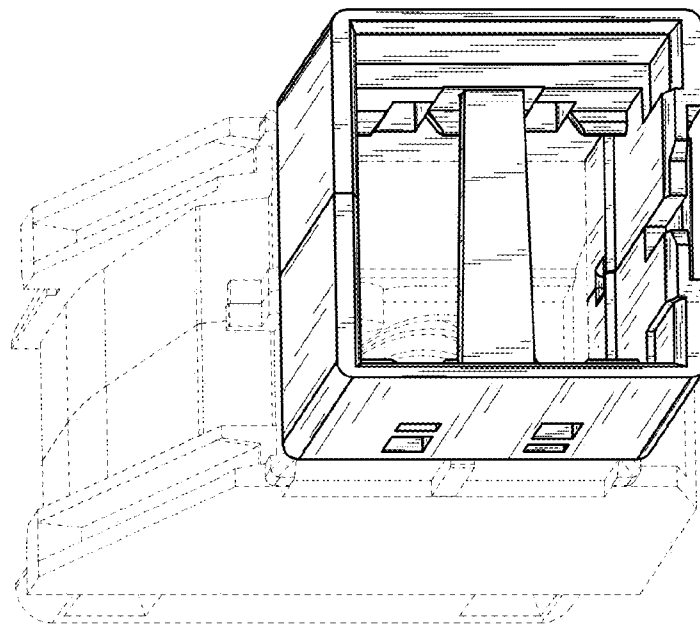

Fig.37

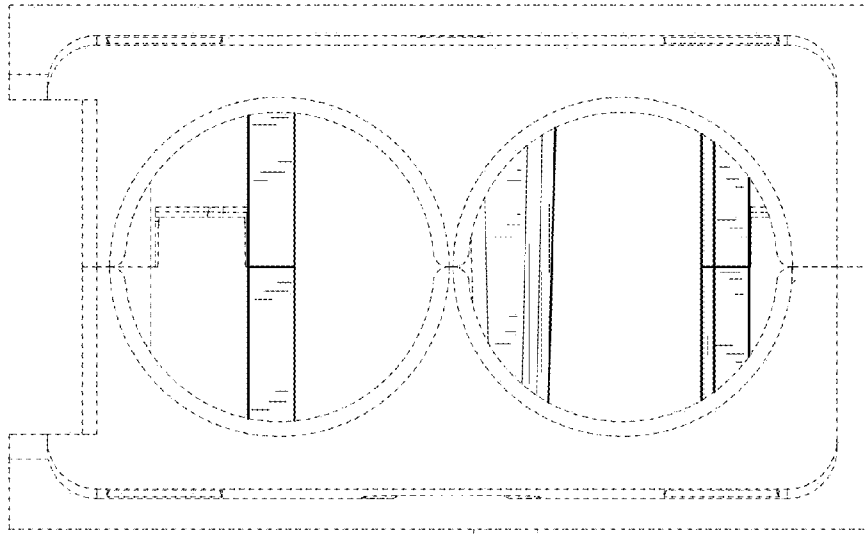

Fig.40

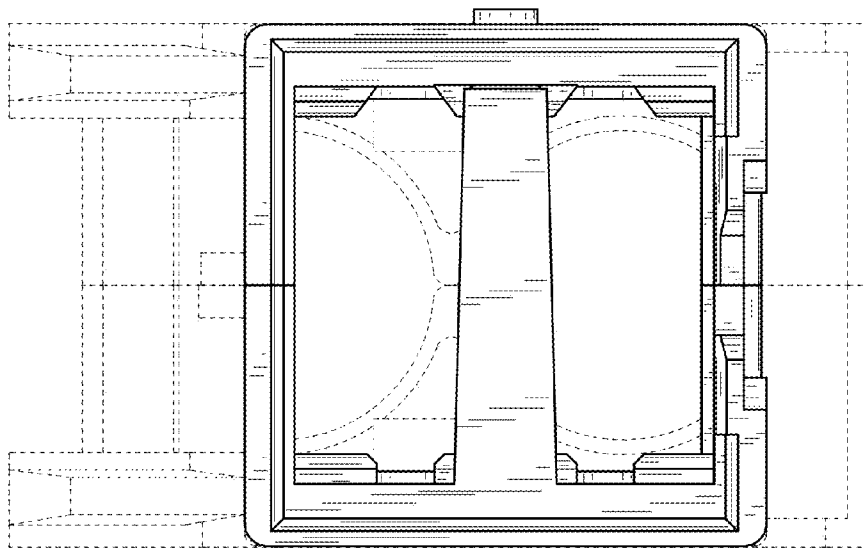

Fig.39

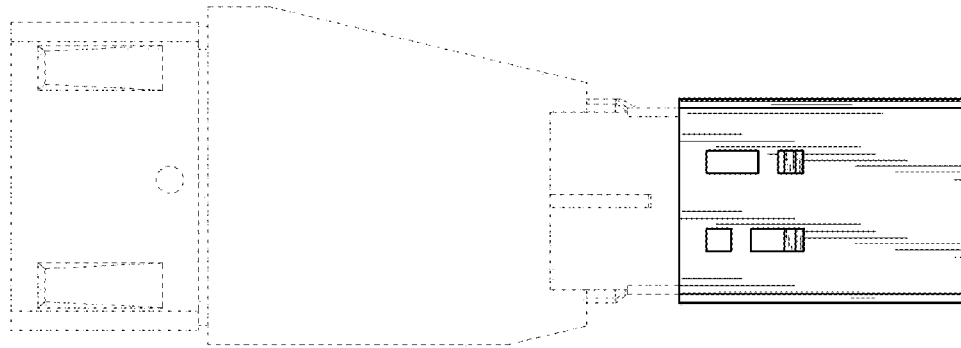

Fig.41

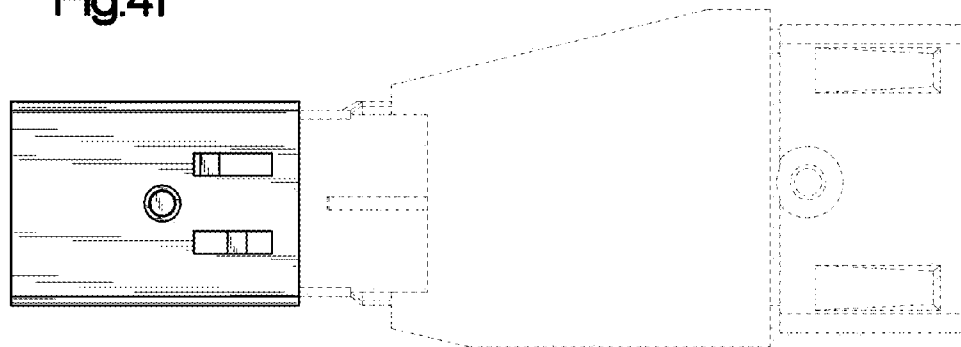

Fig.42

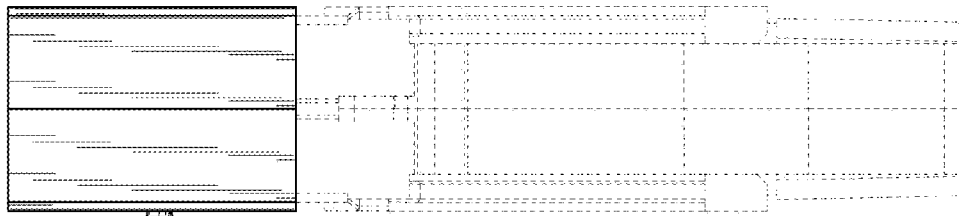

Fig.43

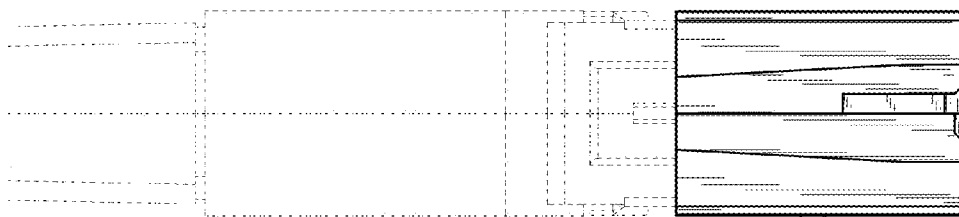

Fig.44

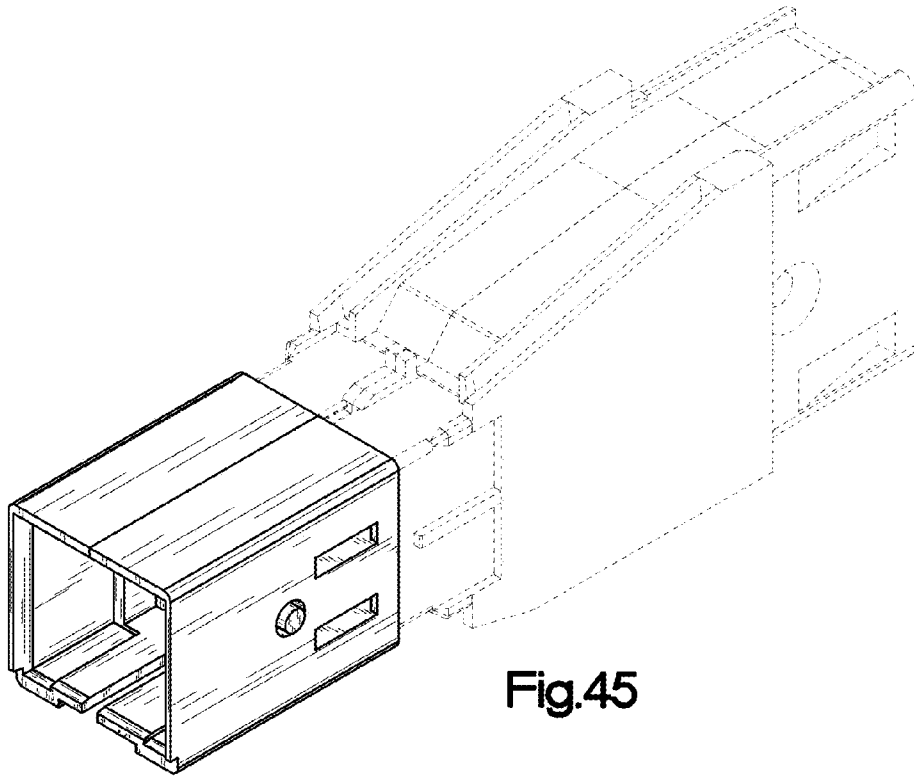

Fig.45

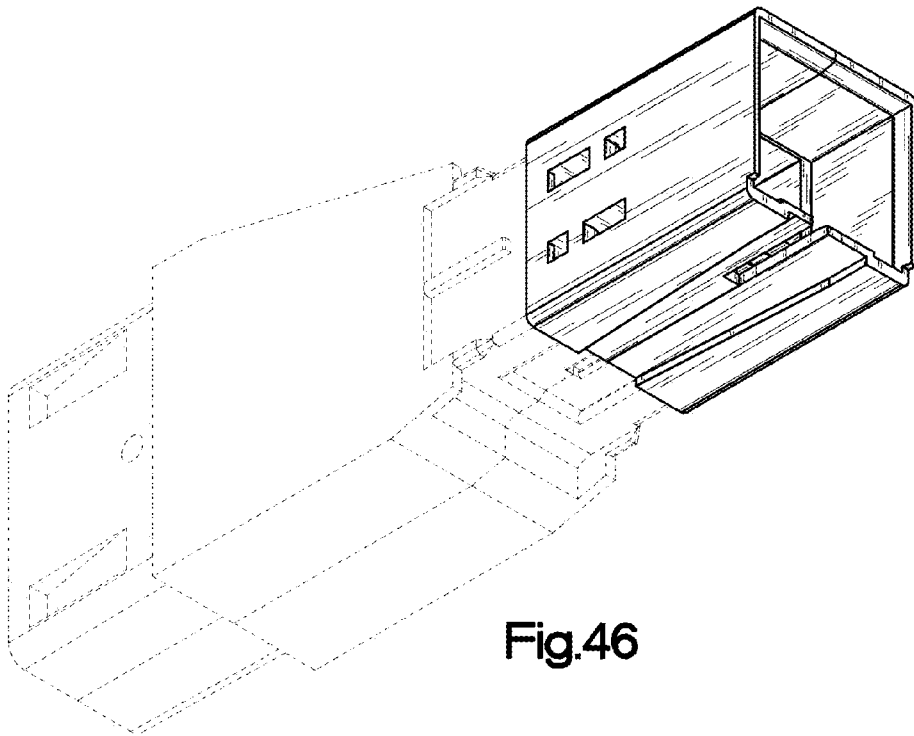

Fig.46

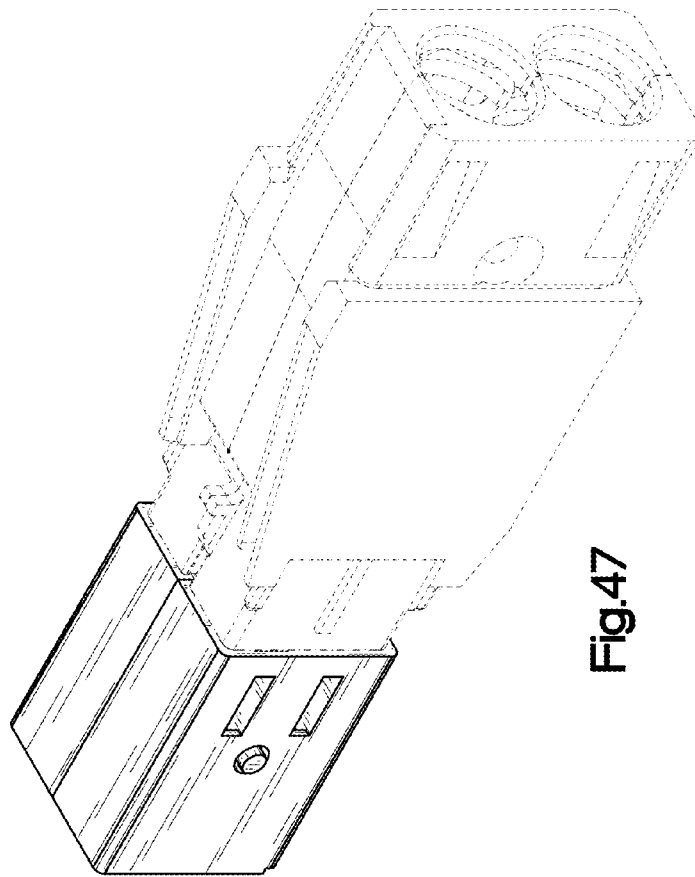

Fig.47

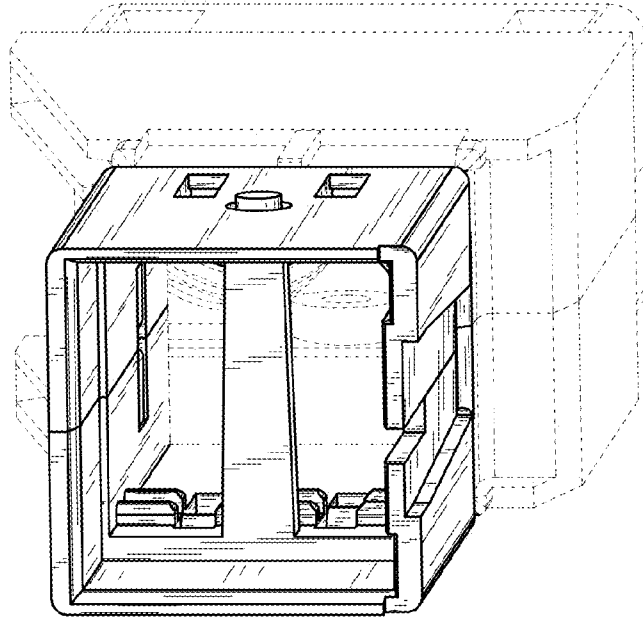

Fig.49

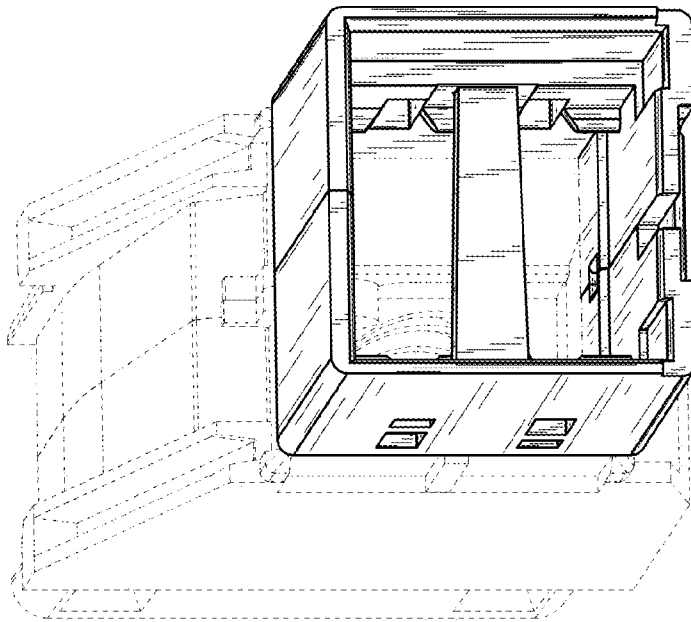

Fig.48

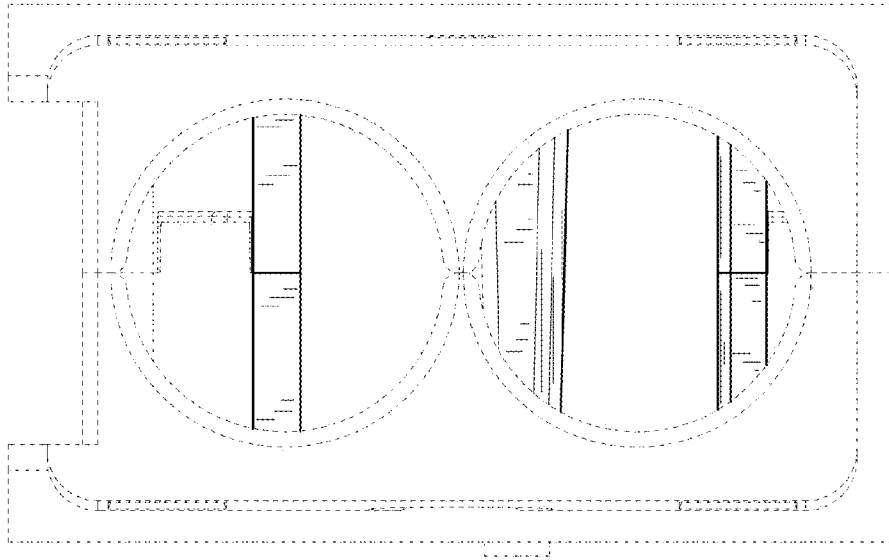

Fig.51

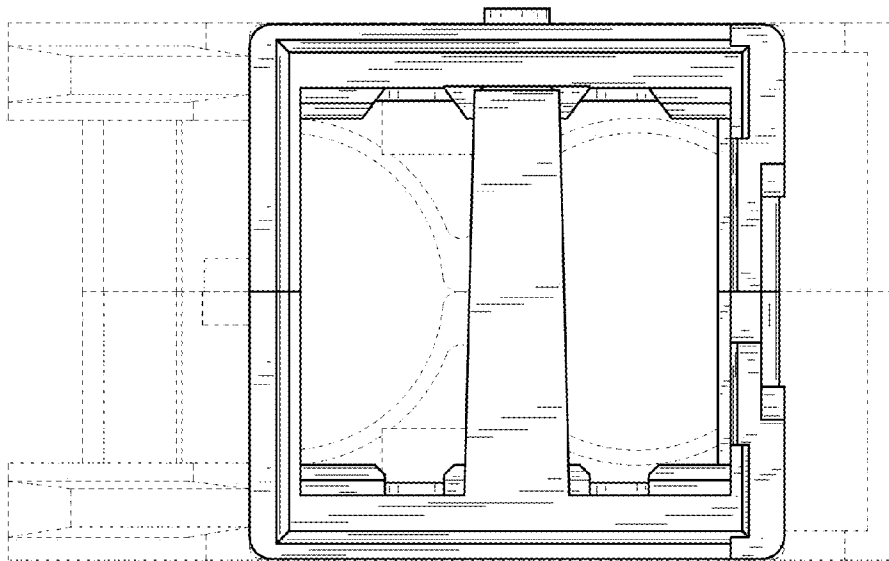

Fig.50

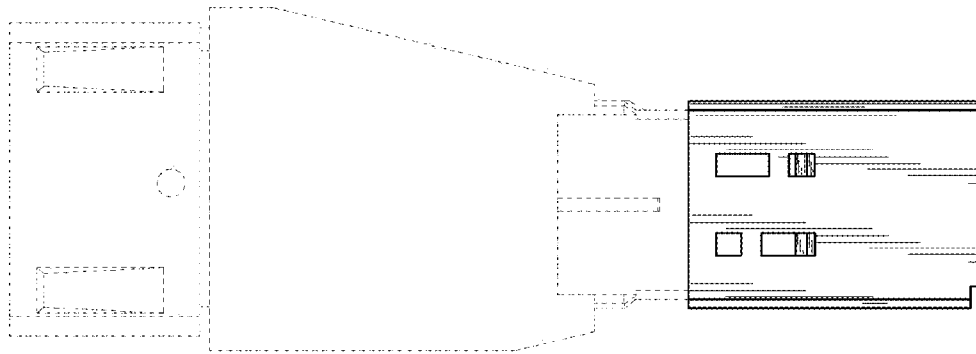

Fig.52

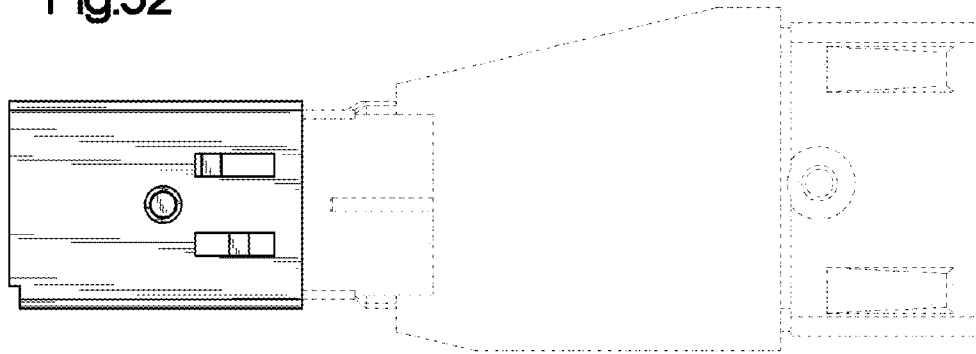

Fig.53

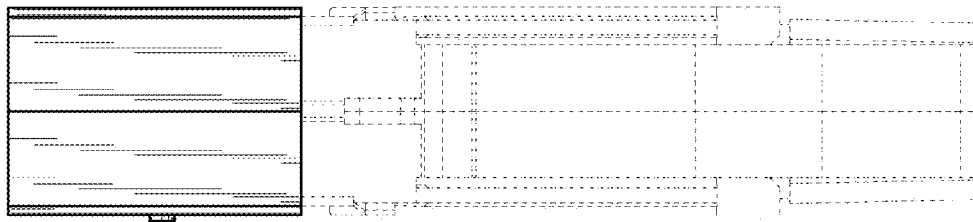

Fig.54

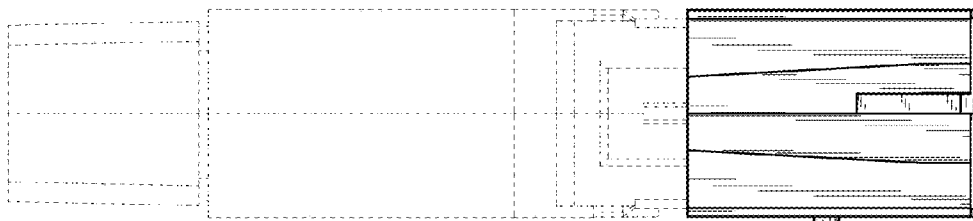

Fig.55