

K. DOUGAN.  
 FEED REGULATOR.  
 APPLICATION FILED JULY 19, 1907.

997,048.

Patented July 4, 1911.

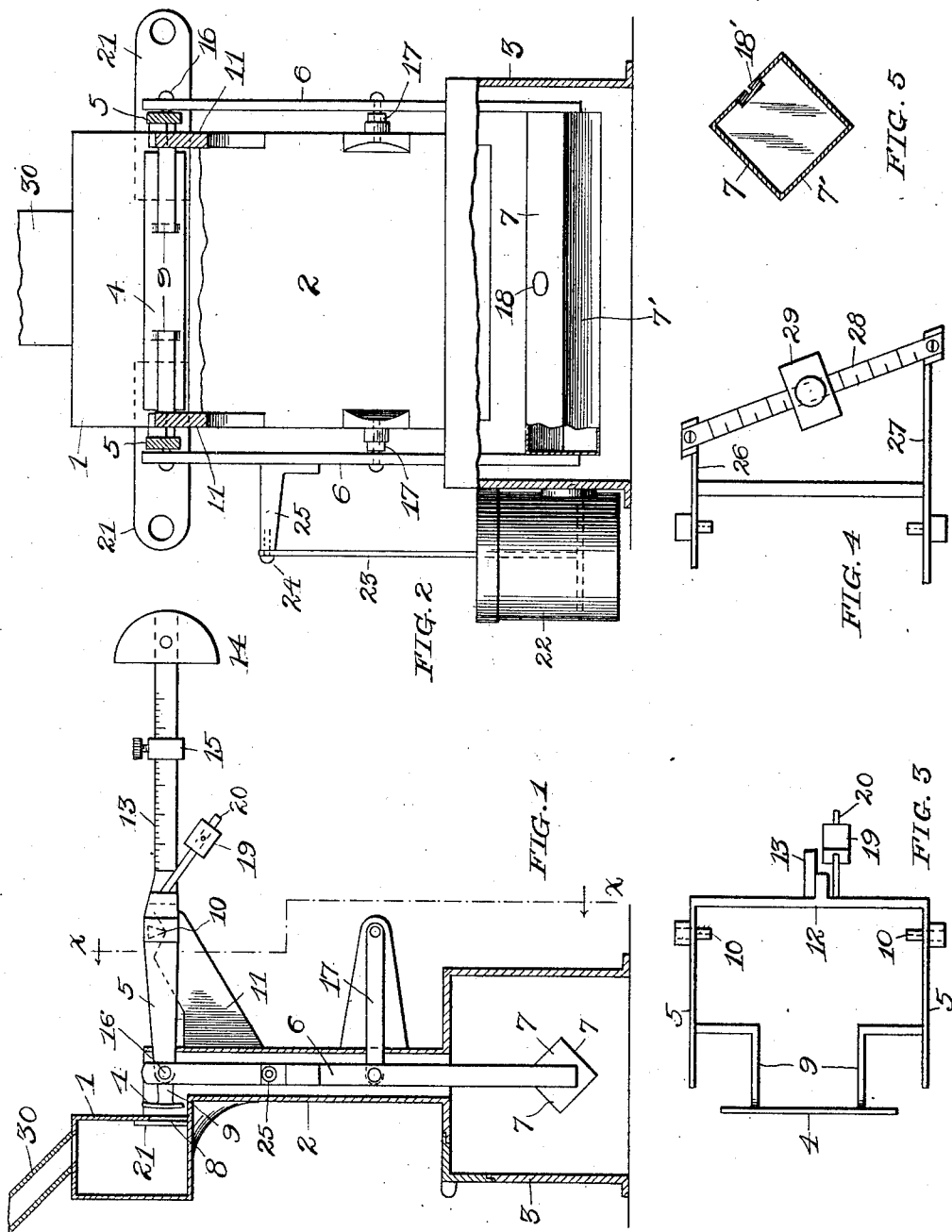

Witnesses:  
 A. M. Imboden,  
 K. Vertz.

Inventor,  
 Kennedy Dougan.

# UNITED STATES PATENT OFFICE.

KENNEDY DOUGAN, OF MINNEAPOLIS, MINNESOTA.

## FEED-REGULATOR.

997,048.

Specification of Letters Patent.

Patented July 4, 1911.

Application filed July 19, 1907. Serial No. 384,588.

To all whom it may concern:

Be it known that I, KENNEDY DOUGAN, a citizen of the United States, residing at Minneapolis, in the county of Hennepin and State of Minnesota, have invented a new and useful Improvement in Feed-Regulators, of which the following is a specification.

This invention relates to feed regulators or governors, and has for its general object to provide a machine that will feed in a continuous unbroken uniform stream, any predetermined number of units of a fluid, such as grain or water, per unit of time, and, in the case of wheat, regardless of the conditions of the wheat relative to its specific gravity, roughness, size, or state of dampness.

A special object of the invention is to provide a feed governor in which the throat and receiver cannot become clogged by the lodging of straws, etc., contained in the grain being operated on.

The features of novelty are pointed out in the appended claims.

A preferred embodiment of the invention is shown in the accompanying drawings, in which—

Figure 1 is a side elevation, partly in section; Fig. 2 is a vertical section viewed on line  $x-x$  of Fig. 1, parts of the casing being broken away; Fig. 3 is a plan of the valve frame, detached; Fig. 4 represents a modified counterweight structure; and Fig. 5 is a detail of the receiver.

The body of the machine comprises the receiving chamber 1, a casing forming the throat 2, having the enlarged lower portion 3, and brackets referred to below. Further the machine comprises a valve or gate 4, mounted on two horizontally disposed arms 5; a pair of depending rods 6 pivotally connected to said arms; and an impact receiving device 7, hereinafter termed the "receiver."

The receiving chamber 1 communicates with the upper end of the throat 2 by an opening 8. The valve or gate 4 is set close to but not in contact with the wall of said opening and is of substantially the same size as the opening. The valve is carried by arms 9, branching from the arms 5, which

latter are provided with knife pivots 10 resting upon brackets 11 secured to the casing of the throat.

Preferably the valve 4 is curved as shown, to the arc of a cylinder whose center is the pivotal axis of the arms 5. Said arms are rigidly connected by a yoke-bar 12 to which is secured the graduated beam 13 provided with a fixed weight 14 and an adjustable weight 15. Depending from the respective arms 5 and pivoted thereto at 16, are two rods or links, 6 which carry at their lower ends the receiver, 7. Openings for said links are provided in the enlarged base 3. The receiver 7 as shown is in the form of a four sided tube disposed horizontally with its opposed upper faces 7 inclined outward and downward.

The links 6 are secured to the ends of this receiver, and are guided by parallel arms 17 which are set parallel to the valve arms 5. By this device, the receiver 7 will always present the same angle to a vertical plane, in any position which it may assume vertically considered. This feature is important, as feed governors having receivers that vary their angle to the stream of material falling upon them are inaccurate, and therefore do not fulfil their purpose.

The receiver is provided with an opening 18 for the reception of shot to be employed for proportioning the weight of the receiver to that of the arm 13, weight 14, etc. Said opening may be made in one end of the receiver if preferred.

The lower two plates 7' of the receiver are not essential to the operation of the stream upon the receiver, but are provided merely to form a receptacle for the shot. When the governor is in use the opening 18 is closed with a plug as 18' seen in Fig. 5.

The beam 5-13 is provided with a compensating weight 19, set upon an inclined rod 20. By properly adjusting this weight 19 at the factory, the uniform regulation of wet and dry grains will be assured. That is to say: by adjusting said weight to a certain point on its beam, (which adjustment is made at the factory) the governor will be caused to feed the same number of units of grain per unit of time, regardless of the spe-

cific gravity, dampness or dryness, smoothness or roughness, of the grain. The weight of the compensating weight 19 is to be made about equal to the average impact force of the grain upon the receiver 7; which force is only about a quarter of one ounce produced by a stream of wheat falling at the rate of 10 bushels per hour.

To prevent the inertia of the movable parts (when in operation) from carrying them too far in either direction, a retarding device or dashpot 22 is employed; its piston-rod 23 being pivotally connected at 24 to a bracket 25 on one of the links 6. The pot 22 is filled with glycerin or the like.

The receiving chamber 1 may be provided with manually operated cutoff slides 21, by which the width of the stream flowing through the opening 8 may be varied to that found to be most practical. A closing movement of the slides is followed by decreased impact upon the receiver, ascent of the gate 4, and such increase of depth of the stream as will maintain the previous rate of flow.

Fig. 4 shows a modified arrangement of the graduated beam that is especially desirable in larger sizes of feed governors. Its purpose is to obviate an inconveniently long beam as 13, projecting outward beyond the body of the machine as in Fig. 1. The arms 5 are extended to unequal lengths, forming arms 26 and 27, between which the beam 28 is disposed horizontally. It is obvious that as the weight 29 is moved along upon the beam it will either approach or recede from the pivotal axis of the yoke, the effect being the same as that of the weight 15 in Fig. 1.

The operation is as follows: The weight 15 is moved to the left to the limit of its movement and secured there by its thumb screw. Shot having previously been placed in the receiver 7 through the hole 18 to put the parts in balance on the pivots 10, grain is spouted into the hopper 1 through a spout 30. The weight 15 is then moved out to the mark on the beam representing the amount it is desired to feed. This will cause the valve 4 to rise and let grain drop onto part 7. When the force of the grain striking the receiver is sufficient to check the further downward movement of weight 15 an equilibrium will be established between the striking force of the grain upon the receiver, and the weights 15 and 19, as the instant the striking force becomes heavier the gate 4 will be closed partly down, and the instant it becomes lighter the gate will be raised by the weight.

I claim as my invention:

1. A feed regulator comprising an inlet chamber having an outlet, a valve or gate adjacent said outlet, an impact receiver in

communication with the stream passing said valve or gate, an operative connection between said receiver and valve, and parallel rock-arms guiding said connection.

2. In a feed regulator, a stationary casing forming a vertical throat for passage of the material to be fed, a valve or gate adjacent the upper end of said throat, an impact receiving member comprising a pair of opposed, outwardly and downwardly inclined plates, positioned to be impinged upon by the falling material, an operative connection between said valve and said receiver and parallel rock-arms guiding said connection.

3. In a feed regulator, a horizontally disposed rock-arm, a fixed support for said arm, a valve or gate actuated by movement of said arm, an inlet chamber having an outlet controlled by said valve or gate, an impact receiver operatively connected with said arm, a downwardly inclined arm rigidly connected with said pivoted arm at the opposite side of the pivot of said arm from said valve or gate, and a compensating weight carried by said downwardly inclined arm, for the purpose specified.

4. In a feed regulator, an inlet chamber having an outlet, a horizontally disposed pivoted arm, a feed-gate carried by said arm adjacent said outlet, a weight mounted adjustably on said arm, a downwardly inclined arm rigidly secured to said first arm, extending away from the feed-gate, a compensating weight mounted on said inclined arm, a movable impact receiver, and operative connection between said receiver and the first named arm.

5. In a feed regulator, a horizontally disposed arm fulcrumed on hair pivot bearings and provided at opposite sides of said bearings with a valve and a counterweight; an inlet chamber having an outlet adjacent said valve; an impact receiver, operative connections between said receiver and said arm, and parallel rock-arms guiding said connections.

6. In a feed regulator, a frame, an inlet chamber having an outlet, upper and lower parallel arms horizontally disposed and pivoted on said frame, a gate or valve carried by said upper arms, links pivotally connecting said upper and lower arms, and an impact receiver supported by said links.

7. In a feed regulator, a casing forming a throat for the stream to be governed, upper and lower parallel arms pivoted on brackets on said casing, an inlet chamber having an outlet, a gate or valve carried by said upper arms to control the flow through said outlet, links pivotally connecting said upper and lower arms, and an impact receiver supported by said links, arranged in said throat below the valve or gate.

8. A feed regulator comprising an inlet chamber having an outlet, a valve or gate for said outlet, an impact receiver located in the path of the stream from said outlet,  
5 an operative connection between said receiver and valve, a pivoted yoke supporting said gate and connection, separate parallel arms pivoted to and guiding said connection, and a retarding device for the movable parts of the regulator.

KENNEDY DOUGAN.

Witnesses:

K. M. IMBODEN,

K. VERTZ.

---

Copies of this patent may be obtained for five cents each, by addressing the "Commissioner of Patents, Washington, D. C."

---