

(12) STANDARD PATENT
(19) AUSTRALIAN PATENT OFFICE

(11) Application No. **AU 2008292775 B2**

(54) Title
Article comprising an impeller

(51) International Patent Classification(s)
F04D 3/00 (2006.01) **F04D 29/18** (2006.01)
F04D 3/02 (2006.01) **F04D 29/24** (2006.01)

(21) Application No: **2008292775** (22) Date of Filing: **2008.09.11**

(87) WIPO No: **WO09/029959**

(30) Priority Data

(31) Number	(32) Date	(33) Country
12/201,561	2008.08.29	US
60/968,864	2007.08.29	US

(43) Publication Date: **2009.03.05**

(44) Accepted Journal Date: **2012.01.12**

(71) Applicant(s)
Medical Value Partners, LLC.

(72) Inventor(s)
Shifflette, Michael J.

(74) Agent / Attorney
Spruson & Ferguson, Level 35 St Martins Tower 31 Market Street, Sydney, NSW, 2000

(56) Related Art
US 3510229 A
US 2006/062672 A1
US 5112292 A
US 5749855 A

(12) INTERNATIONAL APPLICATION PUBLISHED UNDER THE PATENT COOPERATION TREATY (PCT)

(19) World Intellectual Property Organization
International Bureau



(43) International Publication Date
5 March 2009 (05.03.2009)

PCT

(10) International Publication Number
WO 2009/029959 A3

(51) International Patent Classification:
F04D 3/00 (2006.01) *F04D 29/18* (2006.01)
F04D 3/02 (2006.01) *F04D 29/24* (2006.01)

(21) International Application Number:
PCT/US2008/075993

(22) International Filing Date:
11 September 2008 (11.09.2008)

(25) Filing Language: English

(26) Publication Language: English

(30) Priority Data:
60/968,864 29 August 2007 (29.08.2007) US
12/201,561 29 August 2008 (29.08.2008) US

(71) Applicant (for all designated States except US): **MEDICAL VALUE PARTNERS, LLC**, [US/US]; 1800 Century Park East, Suite 600, Los Angeles, CA 90067 (US).

(72) Inventor; and

(75) Inventor/Applicant (for US only): **SHIFFLETTE, J., Michael** [US/US]; 19406 NW. 62 Avenue, Alachua, FL 32615 (US).

(74) Agents: **DEMONT, Jason, Paul** et al.; DEMONT & BREYER, LLC, Suite 250, 100 Commons Way, Holmdel, NJ 07733 (US).

(81) Designated States (unless otherwise indicated, for every kind of national protection available): AF, AG, AI, AM, AO, AT, AU, AZ, BA, BB, BG, BH, BR, BW, BY, BZ, CA, CH, CN, CO, CR, CU, CZ, DE, DK, DM, DO, DZ, EC, EE, EG, ES, FI, GB, GD, GE, GH, GM, GT, HN, HR, HU, ID, IL, IN, IS, JP, KE, KG, KM, KN, KP, KR, KZ, LA, LC, LK, LR, LS, LT, LU, LY, MA, MD, ME, MG, MK, MN, MW, MX, MY, MZ, NA, NG, NI, NO, NZ, OM, PG, PH, PL, PT, RO, RS, RU, SC, SD, SE, SG, SK, SL, SM, ST, SV, SY, TJ, TM, TN, TR, TT, TZ, UA, UG, US, UZ, VC, VN, ZA, ZM, ZW.

(84) Designated States (unless otherwise indicated, for every kind of regional protection available): ARIPO (BW, GH, GM, KE, LS, MW, MZ, NA, SD, SL, SZ, TZ, UG, ZM, ZW), Eurasian (AM, AZ, BY, KG, KZ, MD, RU, TJ, TM), European (AT, BE, BG, CH, CY, CZ, DE, DK, EE, ES, FI, FR, GB, GR, HR, HU, IE, IS, IT, LT, LU, LV, MC, MT, NL, NO, PL, PT, RO, SE, SI, SK, TR), OAPI (BF, BJ, CF, CG, CI, CM, GA, GN, GQ, GW, ML, MR, NE, SN, TD, TG).

Published:

- with international search report
- before the expiration of the time limit for amending the claims and to be republished in the event of receipt of amendments

[Continued on next page]

(54) Title: ARTICLE COMPRISING AN IMPELLER

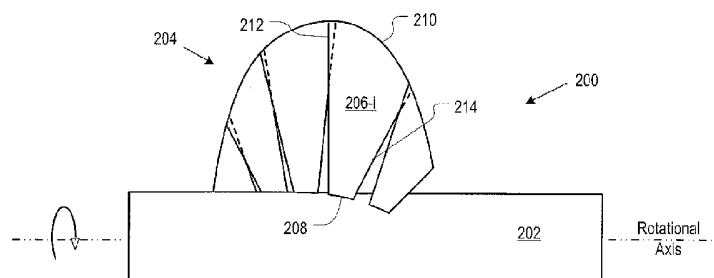

FIG. 2A

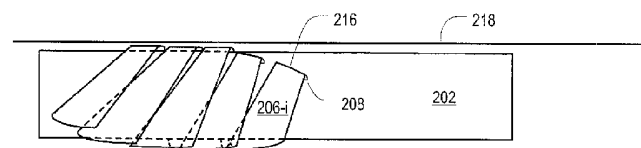

FIG. 2B

(57) Abstract: An impeller for use in conjunction with a percutaneously-insertable blood pump or other rotatable equipment includes a blade that is segmented into a plurality of overlapping or abutting bladelets. In some embodiments, the bladelets are foldable and one side of each bladelet is concave.

WO 2009/029959 A3

WO 2009/029959 A3



— *with information concerning request for restoration of the right of priority in respect of one or more priority claims*

(88) Date of publication of the international search report:

23 April 2009

Article Comprising an Impeller

Statement of Related Cases

[0001] This case claims priority of U.S. Patent Application Serial No. 60/968,864 filed August 29, 2007, which is incorporated herein by reference.

Background

[0002] An impeller is a rotating component that includes a hub and at least one blade. In operation, the impeller is used to accelerate and/or pressurize a fluid. More particularly, an impeller converts the rotary mechanical energy of a drive (*e.g.*, a motor, *etc.*) into kinetic energy (flow) and potential energy (pressure) of a fluid being acted upon. Impellers are used in various types of equipment, including pumps, water jets, agitated tanks, washing machines, and vacuum cleaners, to name but a few.

[0003] The impeller is designed to enable a pump, *etc.*, to achieve certain performance characteristics, such as a certain mass flow rate, pressure ratio, and/or efficiency. Device performance is ultimately a function of the operating conditions (*e.g.*, inlet pressure, temperature, fluid density, *etc.*) as well as geometrical parameters of the impeller (*e.g.*, hub diameter, blade geometry, *etc.*).

[0004] Impeller blades often have a very complex blade geometry intended to optimize hydrodynamic efficiency or meet other design criteria. Furthermore, the structure of impeller blades can vary dramatically as a function of intended application. Consider, for example, an airplane propeller blade or mixer blade. These blades tend to be relatively long in span and short in chord length. Contrast those blades with a screw-type impeller blade (*e.g.*, Archimedes screw, *etc.*) having a single helical vane that exhibits a significant degree of wrap around the central hub. These screw-type blades are relatively short in span and long in chord length.

[0005] There are some specialized applications in which the impellers might have additional design requirements, such as an ability to expand and collapse. One such application is the *percutaneously-inserted* blood pump.

[0006] A blood pump is a cardiac-assist device that is useful as an intervention for some patients who have acute heart failure or who are at risk of developing it. An effective cardiac assist device assumes some of the heart's

pumping function, thereby unloading the heart and enabling it to recover. The blood pump is typically intended as a temporary measure, usually in operation for less than a week.

[0007] Percutaneously-inserted blood pumps are designed to be inserted into a patient using a minimally-invasive procedure. These blood pumps are usually inserted via established cath-lab techniques, such as by inserting the blood pump into a peripheral vessel (*e.g.*, femoral artery, *etc.*) and advancing it to the ascending aorta or the heart (*e.g.*, Seldinger, *etc.*). To be percutaneously inserted into a peripheral vessel, a blood pump must be quite small. In particular, it is desirable for these blood pumps to have a 12-French (4 millimeter) or smaller catheter. This places a severe constraint on the size of the impeller blades and, hence, the amount of blood that the device can pump.

[0008] In an attempt to address this size constraint, the "expandable" blood pump has been proposed. This type of pump, which is suitably small for percutaneous insertion, includes an impeller that expands once in place within the heart or larger vasculature nearby. The blade span attained by the expanded impeller is greater than is otherwise possible for a non-expandable impeller (that is also percutaneously inserted). As a consequence, the expandable impeller can pump more blood per revolution and operate at a lower rotational speed. Most expandable blood pumps use one of several different implementations of the expandable impeller: inflatable impellers, pivoting impellers, or foldable impellers. Some examples of prior-art blood pumps that use these types of impellers are discussed below.

[0009] U.S. Pat. No. 6,981,942 discloses a percutaneously-insertable blood pump having an inflatable housing and an inflatable impeller, which includes an inflatable hub and a single blade-row of inflatable blades. The housing is attached to a long sheath that couples the pump (ultimately sited in/near the heart) to extracorporeal elements, such as a motor and source of pressurized air. A drive shaft that couples the impeller to the motor and inflation tubes for inflating the housing and impeller are disposed in the sheath.

[0010] U.S. Pat. No. 5,749,855 discloses a percutaneously-insertable blood pump having a pivoting impeller. The impeller comprises a single blade row of two blades that are surrounded by an expandable cage. A drive cable extends from an extracorporeal motor to the distal end of the cage. In the absence of an applied, axially-directed force, the cage and impeller remain in a collapsed state.

[0011] The drive cable is designed so that its inner part is movable relative to its outer part. As the inner part of the drive cable is drawn in the proximal direction by an axially-applied force (e.g., by a medical practitioner tugging on the inner part), relative movement between the inner and outer parts of the drive cable expands the cage and pivots the blades into a deployed state. The deployed propeller can then freely spin within the expanded cage.

[0012] U.S. Pat. No. 6,533,716 discloses a percutaneously-insertable blood pump having a foldable helical rotor. The rotor consists of a helical frame, which is embodied as a helically-twisted segment of Nitinol wire. Both ends of the helically-twisted segment are coupled to an elastic band that lies along the axis of rotation of the helical frame. A surface of the rotor "blade" is formed from a membrane that extends between the helical frame and the centrally-disposed elastic band. The membrane is formed from a spongy, woven tissue.

[0013] The helical rotor is in a collapsed state for insertion into the vascular system. In this state, a tube overlies the helical frame and forces it into an elongated configuration along the central axis. The centrally-disposed elastic band is under maximum tension and the covering membrane is compressed. When the covering tube is withdrawn, the elongated Nitinol wire contracts axially and assumes the helical shape. As this occurs, the elastic band contracts and the membrane forms a smooth surface that functions as the surface of the rotor.

[0014] U.S. Pat. No. 4,753,221 discloses a percutaneously-insertable blood pump that includes attributes of both inflatable and foldable impellers. This blood pump comprises a catheter, the distal end of which is formed from a flexible material that is capable of expanding. Blades, which are disposed in a single blade row, are formed from an elastic material and are disposed in the catheter at the flexible region. When the catheter is in a delivery or collapsed state, the blades are "bent over," substantially parallel to the rotational axis of the pump. To deploy the blades, the distal end of the catheter is enlarged by inflating a balloon that couples to the exterior of the catheter. As the distal end of the catheter expands, the blades unfold into an operational position wherein they extend orthogonally to the rotational axis.

[0015] U.S. Pat. No. 4,919,647 discloses a percutaneously-insertable blood pump having a catheter to which four foldable impeller blades arranged in a single blade row are coupled. The blades are formed of an elastic material and are biased to naturally project radially outward. The blades are disposed in the distal end of a catheter, which has a cup-shaped form and is made from an

expandable material. For insertion into a patient, the impeller blades and the cup-shaped portion are contracted radially inward, such as by placing the catheter within a tubular guide. When the guide is removed, the blades and the cup-shaped portion expand.

[0016] U.S. Publ. Pat. Appl. No. 2008/0114339 discloses a percutaneously-insertable blood pump having an impeller with foldable blades arranged in a plurality of blade rows. This reference discloses that it is difficult to fold a long helical blade that exhibits a substantial amount of wrap around the central hub. To address this problem, the reference discloses that a long blade should be segregated into two, three or perhaps more shorter blades that are arranged (*i.e.*, spaced apart) into a like number of blade rows.

[0017] Although impeller design is a well-understood discipline, the expandable impeller, especially in the context of a blood pump, raises a variety of design challenges. In particular, and among any other issues, careful consideration must be paid to the structural adaption of the impeller that enables it to expand/collapse and the manner in which expansion/collapse is actuated. These issues are important because they typically affect the structural configuration of the surrounding pump structure (*e.g.*, pump housing, *etc.*) and the way in which the impeller is integrated in the surrounding structure.

[0018] It is notable that even though the patent literature is replete with expandable blood pumps, including those discussed above, not one of them is currently in use. A need therefore remains for an expandable impeller that can be used in percutaneously-insertable blood pumps, among other applications.

Object of the Invention

[0019] It is the object of the present invention to substantially overcome or ameliorate one or more of the disadvantages of the prior art, or at least provide a useful alternative.

Summary of the Invention

[0020] In accordance with an aspect of the present invention, there is provided an apparatus comprising an impeller, wherein the impeller comprises:

a hub; and

a first plurality of bladelets disposed on the hub, wherein the first plurality of bladelets collectively define a first blade, wherein each bladelet has a root, a tip, a pressure face and a suction face, and further wherein:

- (a) each bladelet is movable between a deployed state in which the tip thereof is relatively further from the hub and a non-deployed state in which the tip is relatively closer to the hub;
- (b) the pressure face of each bladelet is concave; and
- (c) the root of each bladelet is narrower than the tip of each bladelet.

[0021] In accordance with another aspect of the present invention, there is provided an apparatus comprising an impeller, wherein the impeller comprises:

a hub; and

a first plurality of bladelets disposed on the hub, wherein the first plurality of bladelets collectively define a first blade, wherein each bladelet has a root and a tip, and further wherein each bladelet is movable between a deployed state in which the tip thereof is relatively further from the hub and a non-deployed state in which the tip is relatively closer to the hub.

[0022] In accordance with another aspect of the present invention, there is provided an apparatus comprising a temporary cardiac-assist device, comprising:

a flexible drive cable;

a rigid drive shaft, wherein the flexible drive cable and the rigid drive shaft are coupled to one another;

an impeller hub, wherein the impeller hub is operatively coupled to the drive shaft;

and

a first plurality of individually-movable bladelets disposed on the impeller hub, wherein the first plurality of bladelets collectively define a first blade, and wherein each bladelet is movable between a deployed state in which a tip thereof is relatively further from the hub and a non-deployed state in which the tip is relatively closer to the hub.

[0023] In accordance with another aspect of the present invention, there is provided an apparatus comprising a single-stage impeller having a single blade row, wherein the single-stage impeller comprises:

- a hub;
- a first blade depending from the hub; and
- a second blade depending from the hub and diametrically opposed to the first blade,

wherein:

- (a) the blade row comprises the first blade and the second blade;
- (b) the first blade and the second blade are segmented into bladelets, each bladelet having a root, a tip, and a pressure face;
- (c) the bladelets are widest at the tip thereof and narrowest at the root;
- (d) each bladelet is foldable proximate to the root thereof; and
- (e) the pressure face of each bladelet is concave.

[0024] – [0034] *Left intentionally Blank*

Brief Description of the Drawings

[0035] Preferred embodiments of the invention will be described hereinafter, by way of examples only, with reference to the accompanying drawings.

[0036] FIG. 1A depicts a representation of a prior-art impeller having a single blade row.

[0037] FIG. 1B depicts a representation of a prior-art impeller having two blade rows.

[0038] FIG. 2A depicts an embodiment of an impeller comprising bladelets in accordance with the illustrative embodiment of the present invention. The impeller is shown in a deployed or unfolded state and depicts overlap between adjacent bladelets.

[0039] FIG. 2B depicts the impeller of FIG. 2A, but in folded or delivery state.

[0040] FIG. 3 depicts an embodiment of an impeller comprising abutting bladelets in accordance with the present teachings. The impeller depicts a helical blade that exhibits more than 180 degrees of wrap around the hub.

[0041] FIG. 4A depicts an end view of an impeller in accordance with the present teachings, wherein the impeller has one blade row with two blades and exhibits bilateral symmetry.

[0042] FIG. 4B depicts an end view of an impeller in accordance with the present teachings, wherein the impeller has one blade row with three blades and exhibits tri-lateral symmetry.

[0043] FIG. 5 depicts an embodiment of an impeller comprising bladelets in accordance with the illustrative embodiment of the present invention. The bladelets exhibit a "tape-measure" geometry, wherein one side of each bladelet is concave and the other is convex.

[0044] FIG. 6 depicts further detail of a bladelet exhibiting tape-measure geometry in accordance with present teachings.

[0045] FIG. 7 depicts an embodiment of an impeller similar to FIG. 5 and wherein the bladelets of the blade are in a folded or delivery state.

[0046] FIG. 8A depicts an embodiment of an impeller in accordance with the present teachings, wherein a blade, which comprises a plurality of bladelets, is covered by a membrane.

[0047] FIG. 8B depicts an embodiment of an impeller in accordance with the present teachings, wherein a membrane connects adjacent bladelets of an impeller blade.

[0048] FIG. 9A depicts a blood pump that incorporates an expandable impeller in accordance with the present teachings. The blood pump is shown in an operational state in which the impeller is deployed or unfolded.

[0049] FIG. 9B depicts the blood pump of FIG. 9A, wherein the blood pump is shown in a collapsed or delivery state in which the impeller is folded.

Detailed Description

[0050] The following explicit definitions are provided for various terms that appear in this disclosure and the appended claims and are to be used for the interpretation thereof.

[0051] "**Bladelet**" means a discrete segment of an impeller blade; that is, a plurality of bladelets compose a single impeller blade. Tips of adjacent bladelets abut one another or overlap. (Non-traditional definition.)

[0052] "**Blade row**" is a grouping of impeller blades that have a similar axial position along a hub and are typically equally circumferentially spaced apart. By way of example, FIGs. 1A and 1B depict conventional impellers with blades arranged in blade rows.

[0053] FIG. 1A depicts impeller **100A**, which has four blades **104** that are grouped into a single blade row **106** on hub **102**. Blades **104** are relatively long in span and short in chord, like those of an airplane propeller. FIG. 1B depicts impeller **100B** having hub **112** that supports two blades rows **120** and **124** each having two impeller blades. Blades **114-1** and **114-2** are arranged in blade row **120**. Similarly, blades **118-1** and **118-2** are arranged in blade row **124**. The blades in blade rows **120** and **124** are long helical blades that exhibit a significant degree of wrap around hub **112**.

[0054] The blades within a given blade row can exhibit a slight axial offset with respect to each other. For example, in blade row **120** of impeller **100B**, leading edge **126-1** of blade **114-1** is forward of leading edge **126-2** of blade **114-2**.

[0055] "**Chord**" or ("**chord length**") is a straight line (or the length thereof) connecting the leading and trailing edges of a blade or bladelet.

[0056] "**Helix**" or "**helical**" means the curve formed by a straight (or curved) line drawn on a plane when that plane is wrapped around a cylindrical (or conical) surface of any kind, especially a right circular cylinder, as the curve of a (variable-pitch) screw.

[0057] "**Multi-stage Pump**" means a pump having an impeller having blade rows of rotating blades that are interspersed between blade rows of stator (non-rotating) blades that are attached to a housing. As a result, the flow path proceeds from rotor to stator (*i.e.*, from one stage to the next) changing direction and using its momentum from the multiple changes in velocity and direction to achieve higher pressure head.

[0058] "**Pressure face**" means, in the context of an impeller blade or bladelet, the pump-discharge-side face.

[0059] "**Root**" means, in the context of an impeller blade or bladelet, the portion thereof nearest to the hub.

[0060] "**Suction face**" means, in the context of an impeller blade or bladelet, the pump-inlet-side face.

[0061] "**Tip**" means, in the context of an impeller blade or bladelet, the portion furthest from the hub.

[0062] Definitions of other terms may appear elsewhere in this disclosure.

[0063] FIG. 2A depicts impeller **200** in accordance with the illustrative embodiment of the present invention. Impeller **200** has hub **202** that supports blade **204**. Embodiments of an impeller in accordance with the present teachings will usually, but not necessarily, include at least two blades. This is particularly important for impellers that are intended to rotate at speeds of thousands of rpm, such as is required for a percutaneously-inserted blood pump. Impeller **200** can be assumed to possess a second blade, which is not shown for the sake of clarity.

[0064] Blade **204** comprises a plurality of bladelets **206-i**. In this embodiment, blade **204** includes five bladelets. In other embodiments, however, fewer bladelets or more bladelets may suitably be used as a function, for example, of the chord length of blade. More particularly, a blade having a relatively longer chord length will generally have more bladelets than a blade having a relatively shorter chord length.

[0065] Each bladelet **206-i** is characterized as having root **208**, tip **210**, leading edge periphery **212** and trailing edge periphery **214**. The distance between root **208** and tip **210** depicts the span of the bladelet. The distance between leading edge periphery **212** and trailing edge periphery **214** depicts the extent of bladelet **206-i** in the chord-wise direction.

[0066] The ratio of the chord of tip **210** to the chord of root **208** of each bladelet is typically in a range from about 1 to about 4, and more typically in a range from about 1.5 to about 3. The ratio of the span of a bladelet to the chord length of tip **210** of a bladelet is typically in a range from about 1 to about 4, and more typically in a range from about 2 to about 4. The ratio of the span of bladelet **206-i** to the diameter of hub **202** is typically in a range from about 0.5 to about 3, and more typically in a range from about 1 to about 2.

[0067] In the embodiment depicted in FIG. 2A, adjacent bladelets overlap near tip **210**. The precise amount of overlap will vary as a function of bladelet geometry; in particular the ratio of the chord length of tip **210** to the chord length of root **208**, among other parameters. The greater the ratio, the greater the overlap, as a function of the root spacing between adjacent bladelets.

[0068] In some embodiments, overlap is minimal, such that the trailing edge and leading edge at tip **210** of adjacent bladelets simply abut each other.

But in all embodiments in accordance with the present teachings, there must be at least minimal contact at the tip of adjacent bladelets. This ensures that the bladelets collectively define a single blade. If space is present between adjacent bladelets, then those bladelets are part of two different blades in two different blade rows.

[0069] In some embodiments, bladelets **206-i** are foldable. In such embodiments, FIG. 2A can be considered to depict the bladelets in an unfolded or deployed state and FIG. 2B shows the bladelets in a folded or delivery state. As depicted in FIG. 2B, bladelets **206-i** fold at location **216** near root **208**.

[0070] It is to be understood that, for drawing convenience, Figures that show an impeller in two different states (*i.e.*, unfolded and folded), such as FIGs. 2A/2B (*see also* FIGs. 5 and 7), do not necessarily depict the same impeller. That is, for pedagogical purposes or other reasons, an impeller might appear as a "right-handed" screw in one Figure and as a "left-handed" screw in what appears to be a complementary Figure. This apparent "inconsistency" is inconsequential since it is not germane to the purpose of the illustrations and will not cause any confusion for those skilled in the art.

[0071] In some embodiments, the bladelets are formed from a material that is characterized by a resilience or an ability to return to a specific configuration once a restraining force that is deforming the bladelets is withdrawn. For example, the bladelets can be folded by advancing conduit **218** (*e.g.*, catheter, *etc.*) over hub **202** and the bladelets. In this folded state, the collapsed diameter of impeller **200** is not substantially larger than the diameter of hub **202**.

[0072] When conduit **218** is withdrawn, the bladelets unfold (via the potential energy stored in the bladelets during the folding process). Bladelets having an ability to fold and unfold are particularly useful in conjunction with percutaneously-inserted blood pumps. An embodiment of blood pump utilizing an impeller in accordance with the present teachings is described later in this disclosure.

[0073] Foldable bladelets can suitably be formed from superelastic Nitinol, stainless steel, or various polymers, such as polyimide, polypropylene, and the like. Hub **202** is suitably formed from stainless steel, nitinol, or any of a variety of polymers.

[0074] The geometry (*e.g.*, chord, *etc.*) of blade **204** is application specific. For most applications, blade **204** will wrap at least partially around hub **202** along a helical path. For use in an expandable blood pump, blade **204** will wrap around hub **202** over an angle that is typically in the range of about 30 to 90 degrees. But, as a function of application specifics, blade **204** can wrap a full 360 degrees or more. FIG. 3 depicts impeller **300**, wherein blade **304** comprising a plurality of bladelets **306-*i*** wraps over 180 degrees about hub **302**.

[0075] As noted in the definition of "blade row," most impellers, and particularly those intended to operate at high rotational speeds, will typically have at least two blades that are equally circumferentially spaced-apart about the impeller hub. That is, the impeller (or blade row) will exhibit *n*-fold symmetry such that the blades are positioned about $360/n$ degrees apart from each other about the circumference of the hub, wherein *n* is the total number of blades in the blade row.

[0076] FIGs. 4A and 4B depict two examples of impellers in accordance with the present teachings that display *n*-fold symmetry. FIG. 4A depicts an end view of impeller **400A** having two blades **404-1** and **404-2**, each comprising a plurality of bladelets **406-1-*i*** and **406-2-*i***, respectively. Blades **404-1** and **404-2** are spaced $360/n$ degrees apart, where *n* equals 2, or 180 degrees apart about hub **402A**. FIG. 4B depicts an end view of impeller **400B** having three blades **404-1**, **404-2**, and **404-3**, each comprising a plurality of bladelets **406-1-*i***, **406-2-*i***, and **406-3-*i***, respectively. Blades **404-1**, **404-2**, and **404-3** are disposed $360/n$ degrees apart, where *n* equals 3, or 120 degrees apart about hub **402B**.

[0077] FIG. 5 depicts impeller **500** in accordance with a variation of the illustrative embodiment. Impeller **500** includes two blades **504-1** and **504-2** that are organized into a single blade row about hub **502**. In accordance with the present teachings, blade **504-1** comprises a plurality of overlapping bladelets **506-1-*i*** and blade **504-2** comprises a plurality of overlapping bladelets **506-2-*i***. In this embodiment, each blade comprises five bladelets.

[0078] The operational rotational direction of impeller **500** is indicated by the arrow in FIG. 5 (*i.e.*, counterclockwise). The fluid to be pumped is flowing "out of the page." As a consequence, the pressure face of each bladelet **506-1-*i*** in blade **504-1** is the "visible" face (in FIG. 5). The suction face of bladelets **506-1-*i*** is the obscured face. Likewise, the pressure face of each bladelet **506-2-*i*** in blade **504-2** is the "visible" face and the suction face is the obscured face.

[0079] In accordance with the illustrative embodiment, the pressure face of the bladelets is concave and the suction face of the bladelets is convex. In other words, during normal operation, the concave face of the bladelets is the leading face (*i.e.*, the face that is pushing through the fluid).

[0080] As previously described, this geometry is analogous to that of a metallic wind-up tape measure. A tape measure can be extended many feet against gravity, yet remain substantially straight if the tape is in a concave-side-up orientation. In this orientation, the concave side of the tape measure is exposed to the load (*i.e.*, gravity). If, however, the tape measure is inverted, so that it assumes a concave-side-down orientation, the tape will readily succumb to gravity and buckle and fold. In this manner, the curvature of the tape measure provides rigidity against buckling/folding when exposed to loads, but only in one direction. Similarly, bladelets **506-1-*i*** and **506-2-*i*** depicted in FIG. 5 provide the same one-way rigidity when exposed to a load, such as the mass of the fluid being pumped. But it is critical that the pressure face is concave.

[0081] FIG. 6 depicts additional detail of an individual bladelet, which is representative of bladelets **506-1-*i*** and **506-2-*i***. Other bladelets that would normally be present to collectively define a blade are not depicted in FIG. 6 for the sake of clarity. The bladelet depicted in FIG. 6 is characterized by root **608**, tip **610**, edge **612** and edge **614**. Face **620** is concave and face **622** is convex.

[0082] Like bladelets **206-*i*** of impeller **200**, the ratio of the chord length of tip **610** to the chord length of root **608** of each concave/convex bladelet is typically in a range from about 1 to about 4, and more typically in a range from about 1.5 to about 3. The ratio of the span of a bladelet to the chord length of tip **610** of a bladelet is typically in a range from about 1 to about 4, and more typically in a range from about 1.5 to about 4. The ratio of the span of a bladelet to the diameter of hub **602** is typically in a range from about 0.5 to about 3, and more typically in a range from about 1 to about 2. The radius of curvature of root **608** is typically in a range of about 0.2 to about 2.5 times the chord length of the root. This equates to curvature for root **608** that is in a range of about 12 degrees to about 150 degrees. More typically, the curvature of root **608** will be within the range of about 30 degrees to about 60 degrees.

[0083] Returning to FIG. 5, adjacent bladelets **506-1-*i*** in blade **504-1** overlap near the tips thereof. Likewise, adjacent bladelets **506-2-*i*** in blade **504-2** overlap near the tips thereof. The precise amount of overlap will vary as a function of bladelet geometry; in particular the ratio of the chord length of tip

610 (FIG. 6) to the chord length of root **608**, among other parameters. The greater the ratio, the greater the overlap, as a function of the root spacing between adjacent bladelets. In some embodiments, overlap is minimal, such that the trailing edge and leading edge at the tip of adjacent bladelets simply abut each other.

[0084] In some embodiments, the concave/convex bladelets disclosed herein are foldable, like bladelets **206-i**. In such embodiments, FIG. 5 can be considered to depict the bladelets of an impeller in an unfolded or deployed state and FIG. 7 shows bladelets of an impeller in a folded or delivery state.

[0085] In some of the embodiments in which the concave/convex bladelets are intended to be foldable, they are formed from a material that is characterized by a resilience or an ability to return to a specific configuration once a restraining force that is deforming the bladelets is withdrawn. Foldable bladelets can suitably be formed from superelastic Nitinol, stainless steel, or various polymers, such as polyimide, polypropylene, and the like.

[0086] For initial deployment (*e.g.*, into a patient's vasculature, *etc.*), foldable concave/convex bladelets can be folded by advancing conduit **728** (*e.g.*, catheter, *etc.*) over hub **702** and bladelets **706-1-i** of blade **706-1** and **706-2-I** of blade **706-2**. (Most of the bladelets of blade **706-2** are obscured.) When conduit **728** is withdrawn, the bladelets unfold via the potential energy stored in the bladelets during the folding process.

[0087] In the various embodiments of impellers disclosed herein, there is some open space between adjacent bladelets beneath the tips thereof. Fluid (*e.g.*, blood, *etc.*) will pass through this space, thereby resulting in decreased impeller efficiency. To prevent that from happening, in some embodiments, a membrane is disposed over or between the bladelets. FIGs. 8A and 8B depict two embodiments of impellers with membranes.

[0088] FIG. 8A depicts impeller **800A** having membrane **830** that completely encapsulates blade **804** and all bladelets **806-i**. The membrane can either be bonded to the root of each bladelet or to hub **802** near the root. FIG. 8B depicts impeller **800B** wherein membrane **840** is implemented as a webbing that is disposed between opposing peripheral edges of adjacent bladelets **806-i**. In other words, in the embodiment depicted in FIG. 8B, membrane **840** covers only a portion of blade **804** whereas for the embodiment depicted in FIG. 8A, membrane **830** covers the full blade.

[0089] As a function of application specifics, the membrane may be formed from polyurethane, silicone, latex rubber, other elastomeric compounds, or a biologic membrane such as bovine pericardium.

[0090] FIGs. 9A and 9B depict the pump-assembly portion **950** of a temporary cardiac assist device or blood pump, as is suitable for percutaneous insertion into the vascular system of a patient.

[0091] Since pump assembly **950** is intended for percutaneous insertion, it is advantageously sized so that it can be introduced into the vascular system (*e.g.*, Femoral artery, *etc.*) via a 12-French or smaller-diameter catheter. Historically, it has been difficult to achieve average flows greater than about 2 to 2.5 liters per minute against physiologic pressures through a 12-French catheter, which has a diameter of 4 millimeters. To that end, pump assembly **950** is collapsed for insertion and delivery, as depicted in FIG. 9B, and expanded for pumping (as depicted in FIG. 9A) when it reaches its intended deployment site.

[0092] Pump assembly **950** includes proximal support housing **952**, impeller **900**, distal support **954**, nose cone **956**, casing **960**, proximal support ring **962**, and distal support ring **964**.

[0093] Pump assembly **950** is based on a design for a percutaneously-inserted, expandable, cardiac-assist device that was disclosed in U.S. Published Pat. Application 2008/0132747, incorporated by reference herein. Pump assembly **950** departs from that design by incorporating an impeller having a plurality of overlapping bladelets as disclosed herein. That document can be referenced for additional information concerning the pump assembly design.

[0094] Impeller **900** comprises impeller hub **902** and two impeller blades **904-1** and **904-2** that are arranged in a single blade row. Each impeller blade comprises a plurality of overlapping bladelets **906-1-*i*** and **906-2-*i***.

[0095] A plurality of spaced-apart ribs **958** are axisymmetrically arranged about central axis **A-A** of pump assembly **950**. The ribs collectively define cage or casing **960**. In the embodiment that is depicted in FIG. 9A, wherein the pump assembly is in the expanded state, the ribs exhibit an arcuate shape, so that open, cage-like casing **960** adopts a typically ellipsoidal or prolate-spheroid form. In this state, the casing exhibits its maximum diameter. This maximum or enlarged diameter is required to accommodate impeller blades **904-1** and **904-2** when they are deployed for operation.

[0096] Casing **960** provides one or more of the following functions:

- it prevents the spinning impeller blades of pump assembly **950** from contacting anatomical features;
- it establishes structural integrity;
- it provides a framework for an overlying membrane.

[0097] Regarding the final point above, a membrane (not depicted for reasons of clarity) covers a portion of casing **960**; the end regions of the casing remain uncovered. The purpose of the membrane is to channel or confine the blood in the vicinity of impeller blades **904-1** and **904-2** so that a flow field develops. Blood enters and exits pump assembly **950** through the uncovered regions of the casing. In various embodiments, the membrane is formed from polyurethane, silicone, latex rubber, or other elastomeric compounds.

[0098] In some embodiments, ribs **958** are formed in such a way (*e.g.*, processing, materials of fabrication, *etc.*) that in the absence of a restraining force, they exhibit the aforementioned non-planar (*e.g.*, arcuate, *etc.*) shape, such that pump assembly **950** “naturally” assumes the expanded configuration. As a consequence, no actuating force is required to place pump assembly **950** into its operating configuration. Rather, for such embodiments, a force must be applied to *restrain* pump assembly **950** from expanding. A super-elastic material such as nitinol, *etc.*, can be used to form ribs **952**.

[0099] Elements of pump assembly **950** are coaxial and, in some cases, linearly arranged with respect to one another. This provides stability to pump assembly **950**. Specifically, in the illustrative embodiment, proximal support housing **952**, impeller hub **902**, and distal support **954** are linearly arranged. Proximal support housing **952** and impeller hub **902** are coaxial with respect to drive shaft **948**. Casing **960**, which comprises ribs **958**, proximal support ring **962**, and distal support ring **964**, is coaxial with respect to proximal support housing **952**, impeller hub **902**, and distal support **954**. In some embodiments, proximal support housing **952**, impeller hub **902**, and distal support **954** comprise injection molded polymer.

[0100] To develop pumping action, torque from an extracorporeal motor (not depicted) must be delivered to impeller blades **904-1** and **904-2**. This is accomplished via a flexible drive cable (not shown) and rigid drive shaft **948**.

[0101] In more detail, the proximal end of the drive cable is coupled to the motor and the distal end of the drive cable is coupled to drive shaft **948**. The drive shaft enters the proximal end of pump assembly **950** and is operatively

coupled to impeller hub **902**. The drive shaft extends a relatively short distance (less than about 3 centimeters) proximal of pump assembly **950**.

[0102] The drive cable and the drive shaft are distinct components and the distinction between them is an important one. In particular, the drive cable must be flexible to enable it to be easily advanced in the vasculature and, if required, beyond the aortic arch. In contrast, drive shaft **948** is rigid in order that the requisite seal and bearing in proximal support housing **952** function properly. Although less preferable, it is possible to operate a pump using only a drive cable (*i.e.*, without a drive shaft), with appropriate modifications to the pump assembly and/or drive cable.

[0103] In the illustrative embodiment, drive shaft **948** passes through proximal support housing **952** to impeller hub **902** and terminates therein. In some embodiments, the drive shaft terminates approximately at the axial mid-point of impeller hub **902**. Proximal support housing **952** provides a non-rotating support surface for the proximal support ring **962**, thereby supporting the proximal end of casing **960**. Since casing **960** does not rotate, it cannot couple to a rotating surface, such as impeller hub **902**.

[0104] Since proximal support housing **952** does not rotate but impeller hub **902** does, they are separated by gap. And since drive shaft **948** passes through proximal support housing **952**, a bearing must be provided within the housing to accommodate the rotational movement of drive shaft **948**. A seal must also be provided within proximal support housing **952** to prevent blood from entering. If blood were to enter housing **952** in the small gap between drive shaft **948** and the bore that accepts it, the blood might be hemolyzed by the action of drive shaft **948**.

[0105] The bore of the bearing within proximal support housing **952** provides substantially all of the structural rigidity for impeller blades **904-1** and **904-2**/impeller hub **902**. Materials suitable for the bearing include, without limitation, low friction polymers, such as Teflon® (polytetrafluoroethylene), Torlon® (polyamide-imide), Rulon® (proprietary polytetrafluoroethylene-based compounds), Vespel® (thermoplastic polyimide) sleeve bearings, biocompatible bearings and the like. In some embodiments, polyurethane or silicon lip seals or o-rings are used as the seal.

[0106] In some embodiments, drive shaft **948** is formed as an integral part of impeller hub **902**. In some other embodiments, impeller hub **902** is

formed around drive shaft **948**. In any case, drive shaft **948** is rigidly coupled to impeller hub **902** to efficiently drive the impeller blades. Drive shaft **948** is formed of stainless steel or other materials having specific dimensions, hardness, surface finish, and radiused edges for damage-free seal insertion. Surface finish will be specified by the bearing or seal manufacturer to ensure compatibility with same.

[0107] In some embodiments, the drive cable (not shown) is formed of stainless steel (but in such a way that the cable remains flexible). In some embodiments, the drive cables disclosed in U.S. Pat. Application S.N. 11/758,402 are used.

[0108] Impeller blades **904-1** and **904-2** are depicted in a deployed or unfolded state in FIG. 9A. In this state, they extend substantially orthogonally from impeller hub **902**.

[0109] The impeller blades comprise a plurality of bladelets, consistent with embodiments described earlier in this disclosure. In preferred embodiments, the bladelets have concave pressure side and a convex suction side, as per impeller **500** of FIG. 5. In the illustrative embodiment, the bladelets of impeller blades **904-1** and **904-2** are biased to deploy; that is, they must be restrained to be kept in the folded state. In that embodiment, the bladelets are formed of a resilient material, as previously described. In some other embodiments, the bladelets must be "spun-up" to the deployed state. In other words, the rotation of the impeller hub causes the bladelets to deploy. In a collapsed state, impeller **900** has a diameter of about 3 millimeters (9 Fr).

[0110] For the illustrative embodiment, the design speed of the impeller is in the range of between about 1,000 RPM to about 20,000 RPM. The impeller is expected to pump at least 2.5 liters per minute of blood at 100 mmHg (4 cP) and 37°C using a 10 Fr delivery system. The impeller is designed for a 100% duty cycle for a seven-day service life.

[0111] The following dimensions provide an impeller design suitable for use in conjunction with pump assembly **950** for the design conditions stated above. It is to be understood that the dimensions are provided as indicative of a typical design for impellers described herein, when used in this service:

Diameter of impeller hub **902**: about 2 millimeters (mm)

Span of impeller bladelets **906-1-i/906-2-i**: about 3 mm

Chord length of bladelets at the root: about 1 mm

Chord length of bladelets at the tip: about 2 mm

Bladelets per blade **904-1/904-2**: typically 3-7

Radius of curvature of bladelets at root: about 1 mm

Radius of curvature of bladelets at tip: greater than 2 mm

[0112] Casing **960** is advantageously supported at its distal end. Such support is provided by distal support **954**, which receives distal support ring **964**. Like proximal support housing **952**, the distal support is not rotating. Since, however, impeller hub **902** is rotating, the impeller hub and distal support **954** are separated by a gap. Because drive shaft **948** does not extend beyond the impeller blades, a locating pin or other means is required to couple distal support **954** to impeller hub **902**.

[0113] In the illustrative embodiment, locating pin **953** depends from proximal end of distal support **954**. The pin couples the proximal end of the distal support to the distal end of impeller hub **902**. Disposed within the distal end of impeller hub **902** are a bearing and seal (not depicted). Since, as previously disclosed, impeller hub **902** is rotating and distal support **954** is not, a bearing is required to accommodate the differential movement. And the seal prevents leakage of blood into impeller hub **902**. In some embodiments, the bearing and seal in the impeller hub are formed of the same materials as the bearing and seal in proximal support housing **952**.

[0114] The distal end of distal support **954** terminates in nose cone **956**, which provides an atraumatic surface that is contoured for easy insertion and navigation through a patient's vascular system.

[0115] FIG. 9B depicts pump assembly **950** in its delivery state. In this state, casing **960** (and pump assembly **950**) exhibits its minimum diameter. In this state, ribs **952** are straight and substantially parallel to axis **A-A** of pump assembly **950**. Casing **960** adopts a substantially cylindrical shape.

[0116] It will be appreciated that to the extent pump assembly **950** has a relatively smaller diameter, the task of negotiating the vascular system, and in particular the aortic arch, is simplified. As a consequence, pump assembly **950** is introduced into the body (*e.g.*, the femoral artery, *etc.*) in the folded or delivery state. Typically, it is after pump assembly **950** has passed the aortic arch and entered the ascending aorta or other final locations that casing **960** is expanded for operation.

[0117] In some embodiments, pump assembly **950** is deployed into the vascular system via an "introducing" tube, such as a catheter, sheath, or the like. In some embodiments, the wall of the introducing tube provides the restraining force to maintain casing **960** in the contracted state. To expand casing **960**, pump assembly **950** is simply advanced beyond the distal end of the tube. To provide this functionality, the introducing tube must possess a suitably radially-inelastic wall. Standard catheters are suitably radially-inelastic for this purpose. In conjunction with the present disclosure, it is within the capabilities of those skilled in the art to provide an introducing tube having a suitably radially-inelastic wall to maintain casing **960** in the contracted state.

[0118] One of either the proximal end or the distal end of casing **960** is movable in an axial direction. This facilitates the expansion and contraction of the casing. In embodiments in which casing **960** is to be collapsed simply by the act of inserting the proximal end of pump assembly **950** into an introduction/extraction catheter, then it is advantageous (but not necessary) for the distal end of casing **960** to be the movable end. In such embodiments, distal support ring **964** is movably coupled to distal support **964** so that it is able to readily slide along the support in either direction.

[0119] Pump assembly **950** may be collapsed as follows for extraction from the vascular system. Optionally, impeller **900** is rotated *slowly* in the reverse direction, such that the convex face of the bladelets becomes the pressure face. By virtue of their structure, the bladelets will readily collapse once the convex side is exposed to a load. Pump assembly is then drawn back into the introducing tube.

[0120] Depending upon materials selection and bladelet geometry, the bladelets might or might not remain collapsed (after the cessation of reverse impeller rotation). For some embodiments in which the bladelets do not remain collapsed, the pump assembly is drawn back into the introducing tube while the impeller is still in motion. The reverse rotational motion is stopped only after the pump assembly is within the introducing tube, wherein the wall of the tube will maintain the bladelets in the collapsed state.

[0121] Alternatively, impeller rotation is simply stopped and pump assembly **950** is drawn back into the introducing tube. One benefit of the curved structure of the bladelets is that, even though the "closure" force is being applied to the side that is best able to resist it, once the buckling force is exceeded, the bladelets will readily fold and collapse against hub **902**.

[0122] It is to be understood that the above-described embodiments are merely illustrative of the present invention and that many variations of the above-described embodiments can be devised by those skilled in the art without departing from the scope of the invention. For example, in this Specification, numerous specific details are provided in order to provide a thorough description and understanding of the illustrative embodiments of the present invention. Those skilled in the art will recognize, however, that the invention can be practiced without one or more of those details, or with other methods, materials, components, *etc.*

[0123] Furthermore, in some instances, well-known structures, materials, or operations are not shown or described in detail to avoid obscuring aspects of the illustrative embodiments. It is understood that the various embodiments shown in the Figures are illustrative, and are not necessarily drawn to scale. Reference throughout the Specification to "one embodiment" or "an embodiment" or "some embodiments" means that a particular feature, structure, material, or characteristic described in connection with the embodiment(s) is included in at least one embodiment of the present invention, but not necessarily all embodiments. Consequently, the appearances of the phrase "in one embodiment," "in an embodiment," or "in some embodiments" in various places throughout the Specification are not necessarily all referring to the same embodiment. Furthermore, the particular features, structures, materials, or characteristics can be combined in any suitable manner in one or more embodiments.

The claims defining the invention are as follows:

1. An apparatus comprising an impeller, wherein the impeller comprises:
a hub; and
a first plurality of bladelets disposed on the hub, wherein the first plurality of bladelets collectively define a first blade, wherein each bladelet has a root, a tip, a pressure face and a suction face, and further wherein:
 - (a) each bladelet is movable between a deployed state in which the tip thereof is relatively further from the hub and a non-deployed state in which the tip is relatively closer to the hub;
 - (b) the pressure face of each bladelet is concave; and
 - (c) the root of each bladelet is narrower than the tip of each bladelet.
2. An apparatus comprising an impeller, wherein the impeller comprises:
a hub; and
a first plurality of bladelets disposed on the hub, wherein the first plurality of bladelets collectively define a first blade, wherein each bladelet has a root and a tip, and further wherein each bladelet is movable between a deployed state in which the tip thereof is relatively further from the hub and a non-deployed state in which the tip is relatively closer to the hub.
3. An apparatus comprising a temporary cardiac-assist device, comprising:
a flexible drive cable;
a rigid drive shaft, wherein the flexible drive cable and the rigid drive shaft are coupled to one another;
an impeller hub, wherein the impeller hub is operatively coupled to the drive shaft;
and
a first plurality of individually-movable bladelets disposed on the impeller hub, wherein the first plurality of bladelets collectively define a first blade, and wherein each bladelet is movable between a deployed state in which a tip thereof is relatively further from the hub and a non-deployed state in which the tip is relatively closer to the hub.

4. The apparatus of any one of claims 1 to 3, further comprising a second plurality of bladelets disposed on the hub, wherein the second plurality of bladelets collectively define a second blade, and wherein the first blade and the second blade collectively define a first blade row, and further wherein the first blade row exhibits n -fold symmetry, wherein n is the number of blades in the first blade row.

5. An apparatus comprising a single-stage impeller having a single blade row, wherein the single-stage impeller comprises:

a hub;

a first blade depending from the hub; and

a second blade depending from the hub and diametrically opposed to the first blade,

wherein:

(a) the blade row comprises the first blade and the second blade;

(b) the first blade and the second blade are segmented into bladelets, each bladelet having a root, a tip, and a pressure face;

(c) the bladelets are widest at the tip thereof and narrowest at the root;

(d) each bladelet is foldable proximate to the root thereof; and

(e) the pressure face of each bladelet is concave.

6. The apparatus of any one of claims 1 to 5, wherein the first plurality of bladelets are helically arranged about the hub.

7. The apparatus of any one of claims 1 to 5, wherein respective tips of adjacent bladelets abut each other.

8. The apparatus of any one of claims 1 to 5, wherein respective tips of adjacent bladelets overlap each other.

9. The apparatus of any one of claims 1 to 5, wherein leading and trailing peripheral edges of each bladelet are straight.

10. The apparatus of any one of claims 1 to 5, wherein a ratio of chord length of the tip to the chord length of the root is at least about 1.5.

11. The apparatus of any one of claims 1 to 5, wherein a ratio of a span of each bladelet to a chord length of the tip of each bladelet is at least about two.

12. The apparatus of any one of claims 1 to 5, further comprising a membrane, wherein the membrane covers at least a portion of the first blade.

13. The apparatus of claims 2 or 3, wherein at least some of the bladelets are widest at the tip and narrowest at the root thereof.

14. The apparatus of any one of claims 2 to 4, wherein each bladelet has a pressure face and a suction face, and further wherein the pressure face of at least some of the bladelets is concave.

15. The apparatus of any one of claims 2 to 4, wherein each bladelet has a pressure face and a suction face, and further wherein the suction face of at least some of the bladelets is convex.

16. The apparatus of any one of claims 1, 2, or 5 further comprising:
a flexible drive cable; and
a rigid drive shaft, wherein the flexible drive cable and the rigid drive shaft are coupled to one another, and further wherein the hub is operatively coupled to the drive shaft.

17. The apparatus of claim 16, further comprising an extracorporeal motor, wherein the motor is coupled to the flexible drive cable.

18. The apparatus of claim 3, further comprising an extracorporeal motor, wherein the motor is coupled to the flexible drive cable.

19. An apparatus substantially as hereinbefore described with reference to the accompanying drawings.

Dated 2 December, 2011

Medical Value Partners, LLC.

Patent Attorneys for the Applicant/Nominated Person

SPRUSON & FERGUSON

FIG. 1A
PRIOR
ART

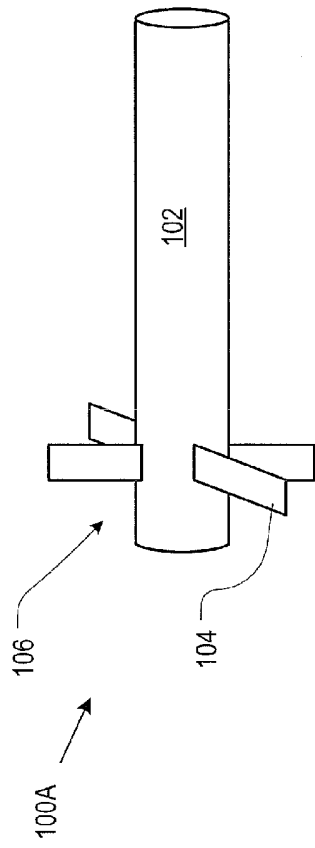
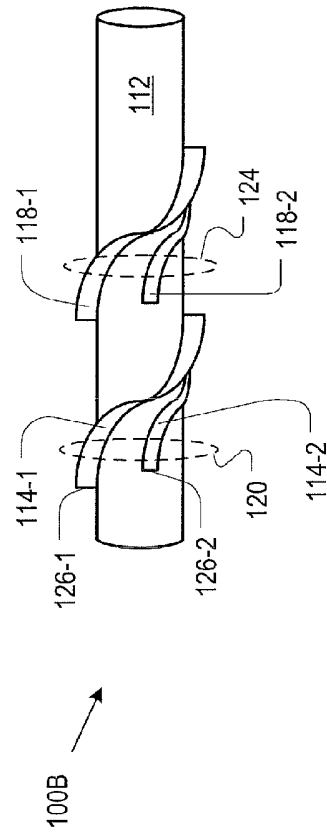

FIG. 1B
PRIOR
ART



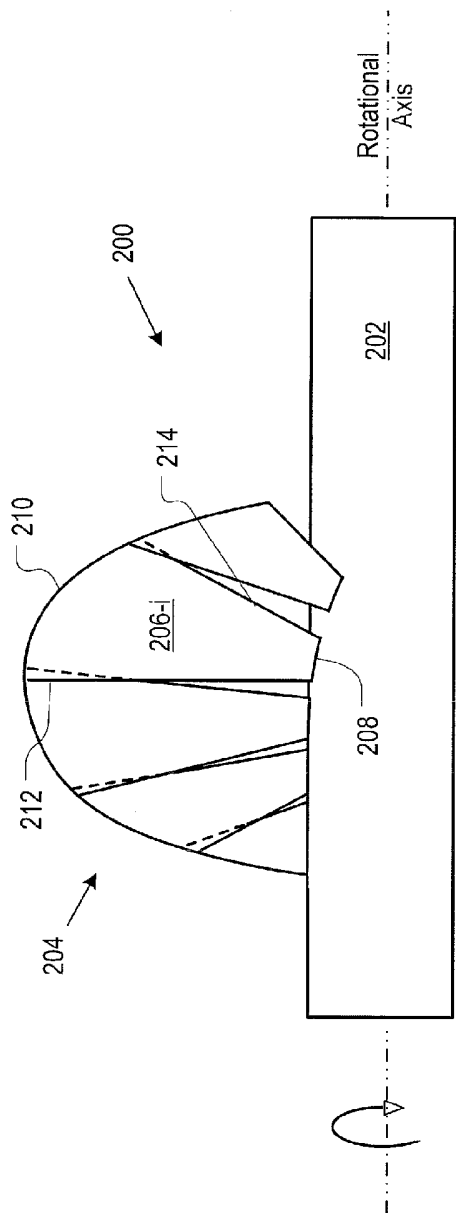

FIG. 2A

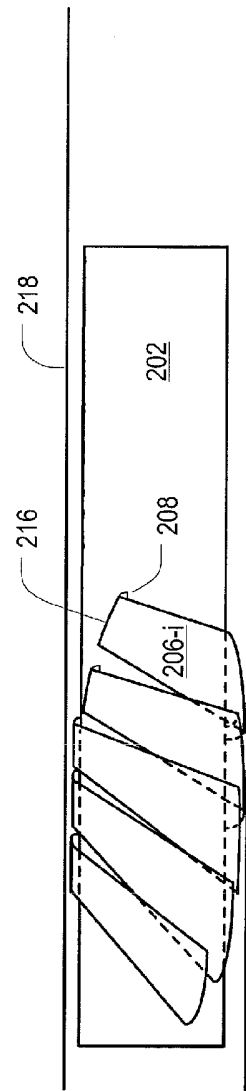

FIG. 2B

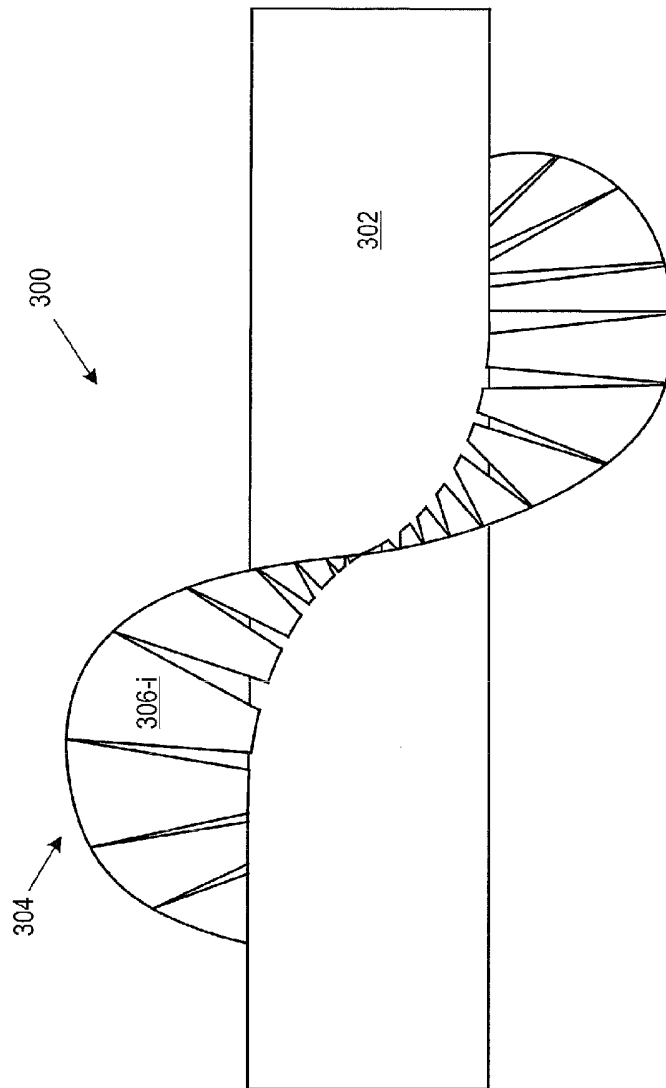
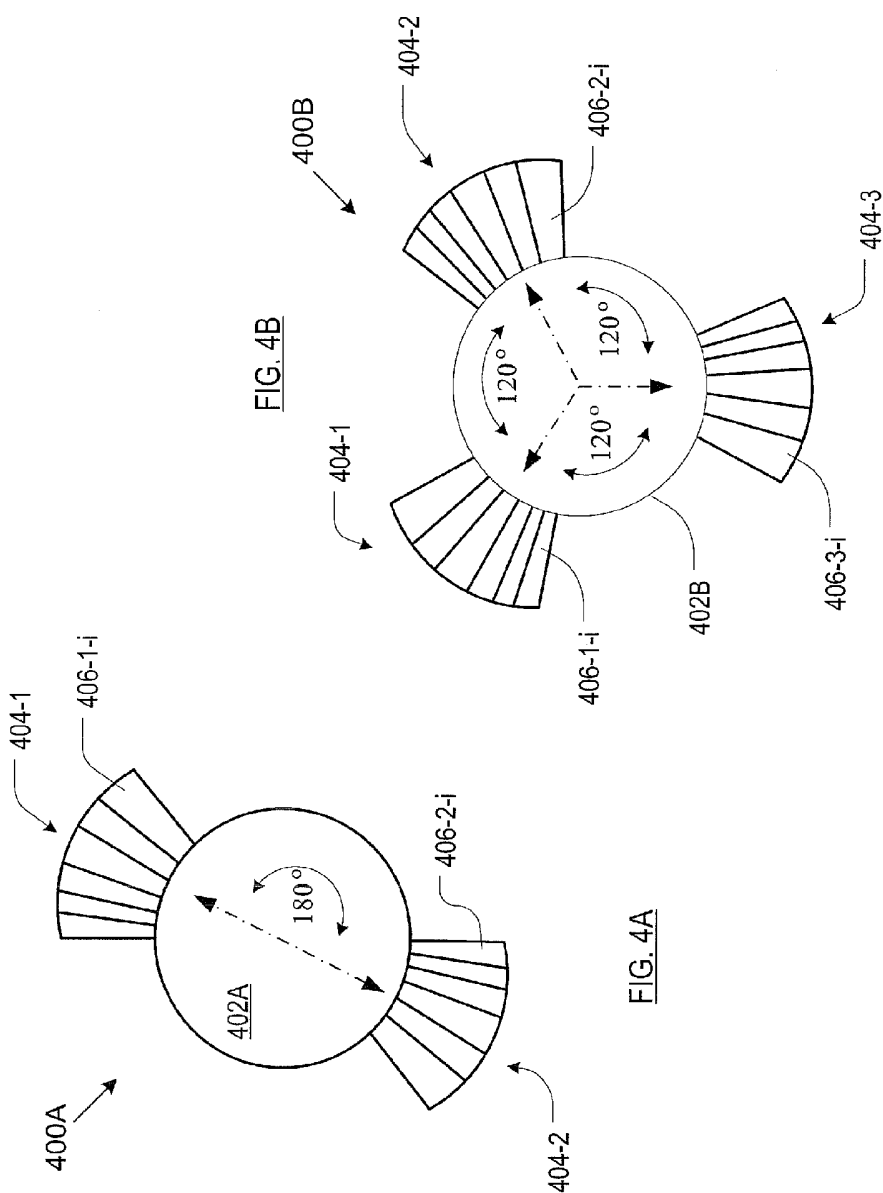

FIG. 3



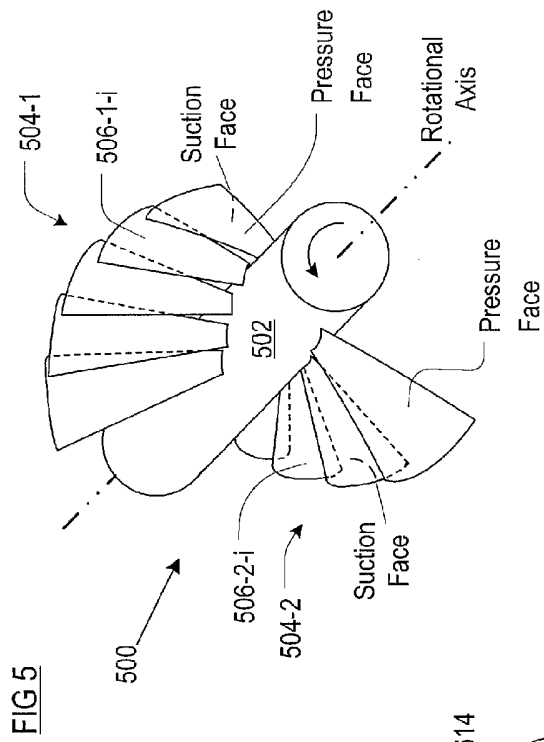

FIG. 5

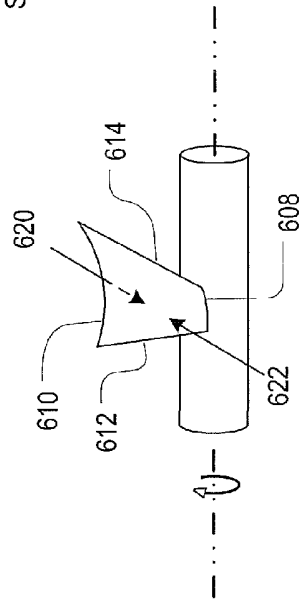

FIG. 6

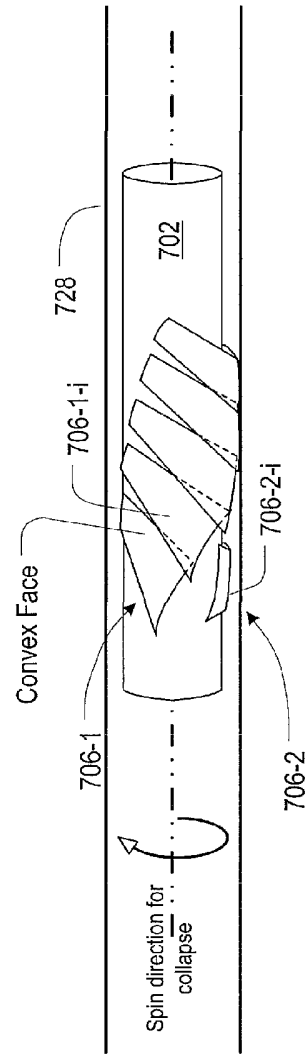

FIG. 7

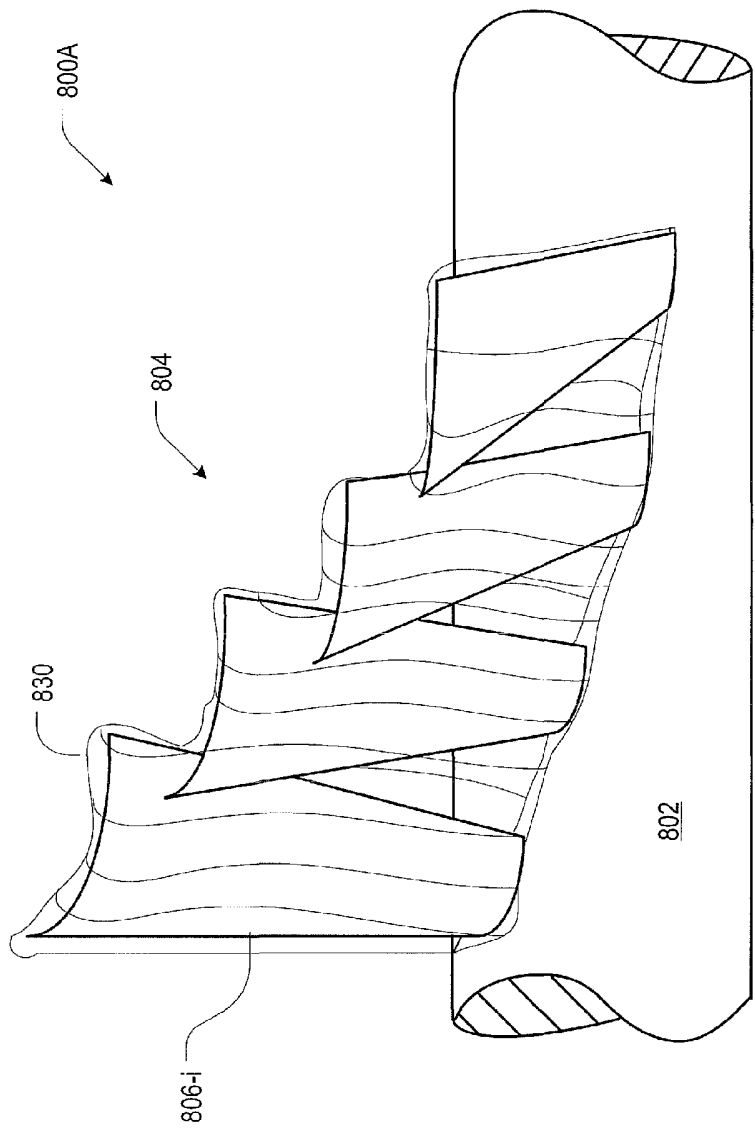

FIG. 8A

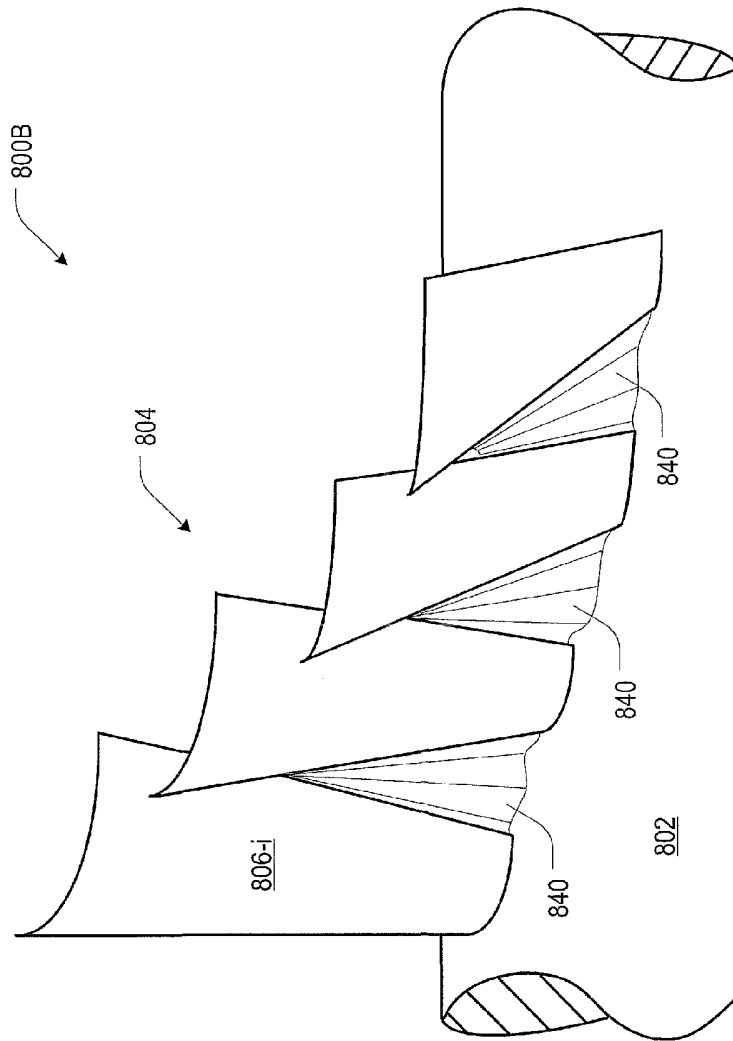

FIG.8B

