

(19) World Intellectual Property Organization  
International Bureau



(43) International Publication Date  
27 September 2007 (27.09.2007)

PCT

(10) International Publication Number  
**WO 2007/108787 A3**

- (51) **International Patent Classification:**  
*B64D 33/02* (2006.01)      *B64D 41/00* (2006.01)
- (21) **International Application Number:**  
PCT/US2006/009023
- (22) **International Filing Date:** 13 March 2006 (13.03.2006)
- (25) **Filing Language:** English
- (26) **Publication Language:** English
- (71) **Applicant (for all designated States except US):** HONEYWELL INTERNATIONAL INC. [US/US]; 101 Columbia Road, P.O. Box 2245, Morristown, NJ 07960 (US).
- (72) **Inventors; and**
- (75) **Inventors/Applicants (for US only):** HEIN, Jeffrey, M. [US/US]; 1834 E. Carver Road, Tempe, AZ 85284 (US). WILLIAMS, Nicholas, A. [US/US]; 844 E. Windsor Avenue, Phoenix, AZ 84006 (US).
- (74) **Agents:** HOIRIIS, David et al.; Honeywell International Inc., 101 Columbia Road, P.O. Box 2245, Morristown, NJ 07960 (US).
- (81) **Designated States (unless otherwise indicated, for every kind of national protection available):** AE, AG, AL, AM, AT, AU, AZ, BA, BB, BG, BR, BW, BY, BZ, CA, CH, CN,

CO, CR, CU, CZ, DE, DK, DM, DZ, EC, EE, EG, ES, FI, GB, GD, GE, GH, GM, HR, HU, ID, IL, IN, IS, JP, KE, KG, KM, KN, KP, KR, KZ, LC, LK, LR, LS, LT, LU, LV, LY, MA, MD, MG, MK, MN, MW, MX, MZ, NA, NG, NI, NO, NZ, OM, PG, PH, PL, PT, RO, RU, SC, SD, SE, SG, SK, SL, SM, SY, TJ, TM, TN, TR, TT, TZ, UA, UG, US, UZ, VC, VN, YU, ZA, ZM, ZW.

(84) **Designated States (unless otherwise indicated, for every kind of regional protection available):** ARIPO (BW, GH, GM, KE, LS, MW, MZ, NA, SD, SL, SZ, TZ, UG, ZM, ZW), Eurasian (AM, AZ, BY, KG, KZ, MD, RU, TJ, TM), European (AT, BE, BG, CH, CY, CZ, DE, DK, EE, ES, FI, FR, GB, GR, HU, IE, IS, IT, LT, LU, LV, MC, NL, PL, PT, RO, SE, SI, SK, TR), OAPI (BF, BJ, CF, CG, CI, CM, GA, GN, GQ, GW, ML, MR, NE, SN, TD, TG).

**Published:**  
— with international search report  
— before the expiration of the time limit for amending the claims and to be republished in the event of receipt of amendments

(88) **Date of publication of the international search report:**  
15 November 2007

For two-letter codes and other abbreviations, refer to the "Guidance Notes on Codes and Abbreviations" appearing at the beginning of each regular issue of the PCT Gazette.

(54) **Title:** PRE-HUNG INLET DOOR SYSTEM

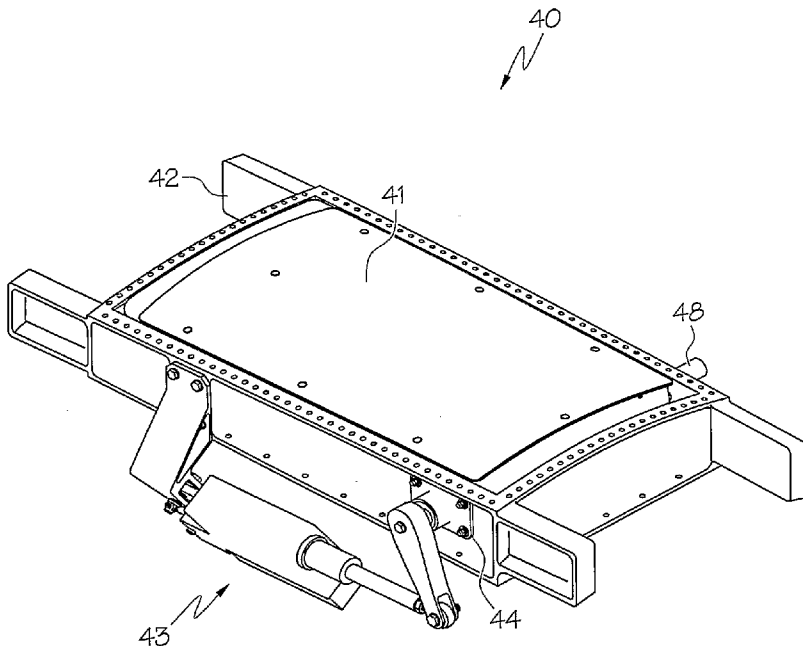

(57) **Abstract:** A pre-hung air inlet door assembly comprises an inlet door (41), a door box frame (42), and an actuation system (43). The door box frame is fastened to the support structure of an aircraft. The inlet door is operationally connected to the actuation system. The entire pre-hung air inlet door assembly can be pre-assembled for quick installation into an aircraft. Pre-assembly eliminates trimming operations and rigging and misalignment issues. The pivot shafts (46, 47) and bearing housings (44, 45) of the pre-hung air inlet door assembly can be accessed from outside the aircraft when repairs and/or replacement components are needed.

WO 2007/108787 A3

**INTERNATIONAL SEARCH REPORT**

International application No  
PCT/US2006/009023

**A. CLASSIFICATION OF SUBJECT MATTER**  
INV. B64D33/02 B64D41/00

According to International Patent Classification (IPC) or to both national classification and IPC

**B. FIELDS SEARCHED**

Minimum documentation searched (classification system followed by classification symbols)  
B64C B64D

Documentation searched other than minimum documentation to the extent that such documents are included in the fields searched

Electronic data base consulted during the international search (name of data base and, where practical, search terms used)

EPO-Internal, WPI Data

**C. DOCUMENTS CONSIDERED TO BE RELEVANT**

Category*	Citation of document, with indication, where appropriate, of the relevant passages	Relevant to claim No.
X	WO 2005/016748 A (HONEYWELL INT INC [US]; HEIN JEFFREY M [US]; BROWN DANIEL [US]; SELLAH) 24 February 2005 (2005-02-24) paragraphs [0019] - [0022]; figures 2, 3A, 5A, 7A, 8A	1-4, 6-10  5
A		
X	US 6 264 137 B1 (SHEORAN YOGENDRA Y [US]) 24 July 2001 (2001-07-24) abstract; figure 2	1-4, 6-10
X	US 6 349 899 B1 (RALSTON MARK D [US]) 26 February 2002 (2002-02-26) cited in the application column 2, line 55 - column 4, line 25; figure 1	1-4, 6-10
	----- -/--	

Further documents are listed in the continuation of Box C.

See patent family annex.

\* Special categories of cited documents :

- \*A\* document defining the general state of the art which is not considered to be of particular relevance
- \*E\* earlier document but published on or after the international filing date
- \*L\* document which may throw doubts on priority claim(s) or which is cited to establish the publication date of another citation or other special reason (as specified)
- \*O\* document referring to an oral disclosure, use, exhibition or other means
- \*P\* document published prior to the international filing date but later than the priority date claimed

- \*T\* later document published after the international filing date or priority date and not in conflict with the application but cited to understand the principle or theory underlying the invention
- \*X\* document of particular relevance; the claimed invention cannot be considered novel or cannot be considered to involve an inventive step when the document is taken alone
- \*Y\* document of particular relevance; the claimed invention cannot be considered to involve an inventive step when the document is combined with one or more other such documents, such combination being obvious to a person skilled in the art.
- \* & \* document member of the same patent family

Date of the actual completion of the international search  
  
27 August 2007

Date of mailing of the international search report  
  
03/09/2007

Name and mailing address of the ISA/  
European Patent Office, P.B. 5818 Patentlaan 2  
NL - 2280 HV Rijswijk  
Tel. (+31-70) 340-2040, Tx. 31 651 epo nl,  
Fax: (+31-70) 340-3016

Authorized officer  
  
Kaysan, Rainer

## INTERNATIONAL SEARCH REPORT

International application No

PCT/US2006/009023

C(Continuation). DOCUMENTS CONSIDERED TO BE RELEVANT		
Category*	Citation of document, with indication, where appropriate, of the relevant passages	Relevant to claim No.
A	US 5 305 969 A (ODELL RICHARD B [US] ET AL) 26 April 1994 (1994-04-26) figure 1	1,5
A	EP 0 876 954 A2 (BOEING CO [US]) 11 November 1998 (1998-11-11) abstract; figure 2	1,5

## INTERNATIONAL SEARCH REPORT

Information on patent family members

International application No

PCT/US2006/009023

Patent document cited in search report		Publication date	Patent family member(s)	Publication date
WO 2005016748	A	24-02-2005	BR PI0412795 A	26-09-2006
			CA 2533394 A1	24-02-2005
			EP 1646560 A2	19-04-2006
			US 2006102781 A1	18-05-2006
			US 2006102776 A1	18-05-2006
			US 2005224635 A1	13-10-2005
US 6264137	B1	24-07-2001	AT 284348 T	15-12-2004
			CA 2401649 A1	30-08-2001
			DE 60107658 D1	13-01-2005
			DE 60107658 T2	16-03-2006
			EP 1257468 A2	20-11-2002
			WO 0162592 A2	30-08-2001
US 6349899	B1	26-02-2002	NONE	
US 5305969	A	26-04-1994	NONE	
EP 0876954	A2	11-11-1998	CA 2236750 A1	09-11-1998
			CN 1212937 A	07-04-1999
			DE 69817911 D1	16-10-2003
			DE 69817911 T2	13-05-2004
			US 5931415 A	03-08-1999