

No. 748,485.

PATENTED DEC. 29, 1903.

W. CURTIS.
WINDMILL.

APPLICATION FILED JUNE 2, 1903.

NO MODEL.

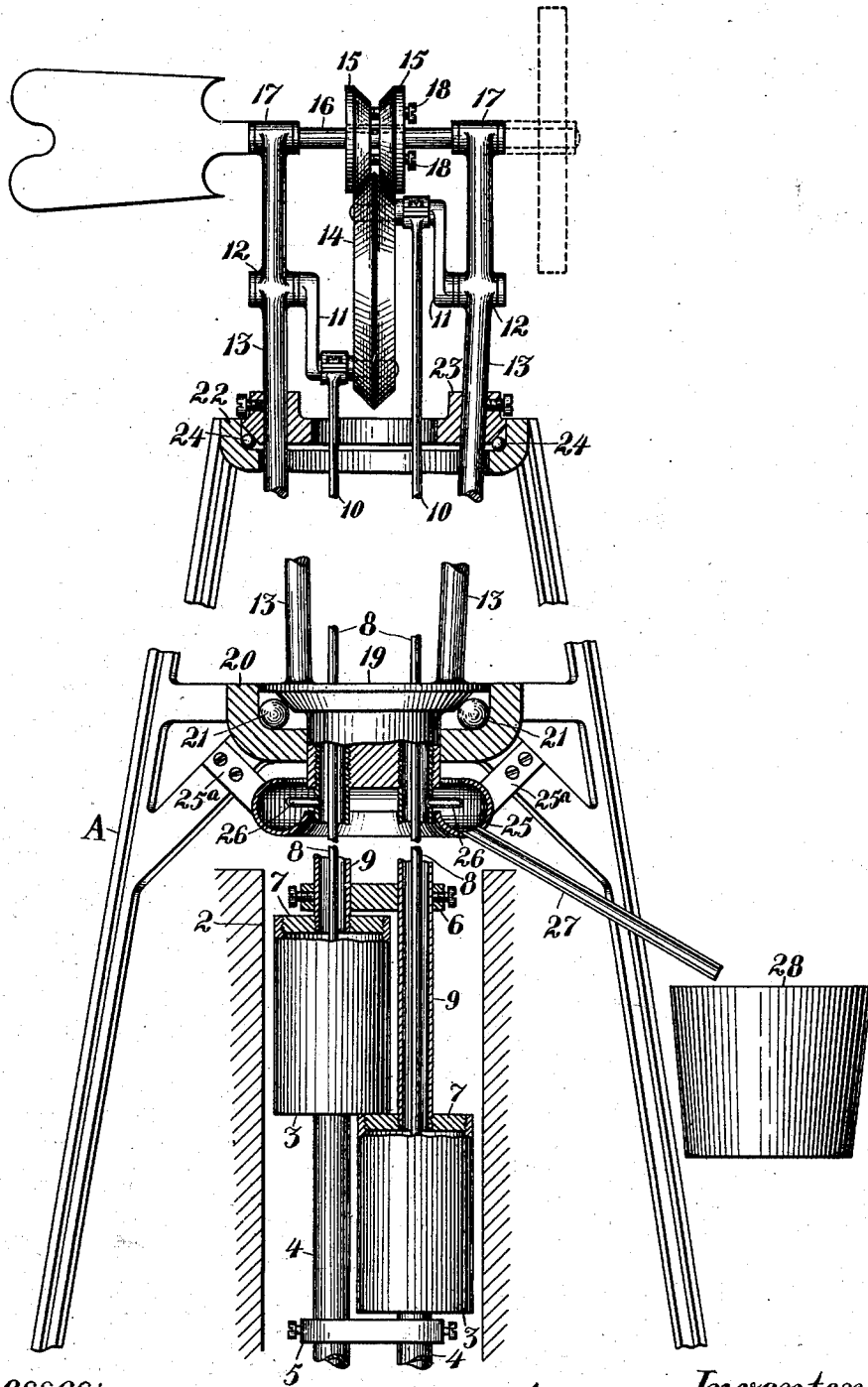

Witnesses:
F. C. Fiedner
J. A. Morse

Inventor:
Winfield Curtis
Geo. H. Strong
att'y

UNITED STATES PATENT OFFICE.

WINFIELD CURTIS, OF SACRAMENTO, CALIFORNIA, ASSIGNOR OF ONE-HALF TO EDWARD F. MAY, OF SAN FRANCISCO, CALIFORNIA.

WINDMILL.

SPECIFICATION forming part of Letters Patent No. 748,485, dated December 29, 1903.

Application filed June 2, 1903. Serial No. 159,747. (No model.)

To all whom it may concern:

Be it known that I, WINFIELD CURTIS, a citizen of the United States, residing at Sacramento, county of Sacramento, State of California, have invented an Improvement in Windmills; and I hereby declare the following to be a full, clear, and exact description of the same.

My invention relates to improvements in windmills.

It consists in a novel means of transmitting power from the wind-wheel shaft to the counter-shaft by which pumping or other mechanism is driven, a means for turnably supporting the wind-wheel and connected mechanism, and arrangement of a pair of pumps and their connection with the mechanism of the mill, so that they may both be disposed within the well and its casing.

It also comprises details of construction which will be more fully explained by reference to the accompanying drawing, in which the figure is an elevation and partial section of my apparatus.

It is the object of my invention to provide a mechanism which is especially designed for pumping and in the supporting of the pumps and mechanism upon antifrictional bearings, so that the mill is easily turnable to allow the wind-wheel to be faced toward the direction from which the wind comes or turned out of the wind when desired.

The connection between the wind-wheel shaft and the counter-shaft, to which power is transmitted, is especially designed to avoid the use of oil or lubricants and to transmit power without the use of gearing, belts, sprocket-chains, or the like.

In the drawings, A represents a framework or support for the apparatus, which may be of the usual form of tower used for windmills or of any suitable or desired construction. The upper and lower portions of the mill are brought closely together, the intermediate portion being cut away, and the well-tube and pumps are in like manner brought up close to the operating parts of the mill for convenience of illustration; but it will be understood that the mill may be placed at any suitable height above the ground and in suitable relation with the well 2, which is located be-

neath it. Within this well are fitted a pair of pumps 3. These pumps may be of any usual or suitable description having plungers and the ordinary well-known arrangement of valves, which are not here shown, as forming no part of the present invention.

The suction-pipes 4 pass through a yoke or clamp 5' at the bottom, and the discharge-pipes 9, which are preferably centrally located, pass through a similar yoke 6 at the top, and the openings in the yokes are so disposed with relation to each other that the two pump-cylinders overlap the side of each one lying close to the suction or discharge pipe of the other. The object of this construction is to allow two pump-cylinders of as large diameter as possible to be placed in a well of less than twice the diameter of the cylinders, and by connecting them, as here shown, by the yokes which form a single structure, which may be let down into the well to the point where they are to be operated. To further economize room I make the pump-cylinder heads 7 without exterior flanges, but thread their outer peripheries and also the interior of the pump-cylinders, so that they may be screwed in without projecting flanges, thus leaving the outsides of the cylinders flush and occupying the least possible space within the well.

The pump-rods 8 are here shown as passing up through the discharge-pipes 9, and the upper ends are suitably guided at the top of said pipes, and by means of pitmen 10 they are connected with the cranks 11. The outer ends of the shafts upon which these cranks are formed are turnable in boxes 12, which are formed or fixed upon the vertical supports 13, as shown, these boxes being transversely in line. The crank-pins to which the pitmen 10 connect pass directly through and are rigidly secured in the friction-wheel 14 and at opposite sides and equidistant from its center, the center of this wheel being in line with the crank-shafts, which turn in the boxes 12, so that the wheel is practically supported from these boxes and turnable concentrically with the shafts therein. The periphery of this wheel may be of any suitable construction. I have here shown it as made V-shaped and adapted to engage with the corresponding

but oppositely-inclined sides of the wheels or disks 15, which are fixed upon the wind-wheel shaft 16. This shaft is journaled in boxes 17 in the top of the standards or supports 13, and the two disks 15 are movable to or from each other by means of adjusting-screws, as 18, so that they may be kept constantly in frictional contact with the periphery of the wheel 14, and in case of wear or a tendency of the surfaces to separate it is only necessary to turn these screws to move the disks a little nearer to each other, and thus insure a sufficient frictional contact, so that the revolution of the shaft 16 will be transmitted to revolve the wheel or disk 14, and thus drive the pumps.

It will be understood that the disks 15 are slidable upon a key or feather, which insures their revolving with the shaft.

The wind-wheel may be supported upon one end of the shaft 16 and the tail-vane upon the other, and any change of the wind will turn the whole apparatus, including the supports or standards 13. In order to allow of this and to make the turning of the apparatus easy, I have shown the lower ends of the standards 13 as fixed upon a turn-table 19.

20 is a circular cup of a greater diameter than that of the turn-table, and within this cup are fitted any desired number of balls or rollers, as at 21, so that the lower surface of the turn-table may rest upon these balls, thus relieving friction as much as possible.

It will be understood that the shape of the cup and the contact-surface of the table may be of any suitable or desired shape to insure the best results.

In order to support and steady the upper portion of the mill, I have shown a cup 22, supported by the mill-frame at a point sufficiently above the cup 20, and within this cup is fitted a disk or runner 23, and this disk or runner is also supported upon balls within the cup, as at 24.

The cup 22 is of annular structure, having a central opening of sufficient diameter for the passage of the pitmen 10, and the disk 23 may be similarly formed, so as to allow for the oscillation of the pitmen as the cranks turn.

In order to avoid as far as possible the necessity of attending to the mill and supplying lubricants, all the bearings at 12 17 and the pitman connections with the cranks are in the form of ball or roller bearings, which will reduce friction and the necessity of attention as much as possible.

The balls 21 and 24 are preferably of considerable diameter, and especially the former, as the whole weight of the mill is practically supported upon the balls 21.

The disk 23 may be fixed to the supports 13, if desired; but it is preferable to allow it freedom of motion, so that while it supports these standards against side movement it will allow the whole weight to rest upon balls 21. It will thus be seen that the whole apparatus, including the pumps, is freely turnable upon

these antifrictional supports, and by reason of the frictional driving between the disks 15 and the disk or wheel 14 power is transmitted by frictional contact. These contacting surfaces may be made wholly of metal, or one surface of metal and the other of fiber or some suitable and equivalent material, so that the noise caused by the rotation of the mill will be reduced to a minimum, and as there are no teeth to be lubricated, as in the case of gearing, but little attention will be needed to maintain the mill in good running order.

25 is an annular chamber fixed at a point near the upper portion of the discharge-pipes 9 and, as here shown, supported below the disk 19 by the brackets 25^a. Pipes or passages 26 open out from the discharge-pipes into the interior of the chamber 25, so that the water lifted through the discharge-pipes is delivered into the annular space within the exterior of this chamber 25.

A pipe 27 serves to convey the fluid from the chamber 25 and discharge it into a tank 28 of any suitable or desired description.

It will be noted that the annular chamber 25 is supported in a stationary manner from the framework of the mill, and the central portion at both top and bottom is open to a sufficient diameter to allow the discharge-pipes and turnable portions of the mill to revolve within this stationary chamber without contact. The discharge-pipes 26, being turnable with the other portions of the mill, may discharge into any portion of the circumference of the receiver 25. By this construction it will be seen that the pumps may be fixed to the discharge-pipes, and these pipes may be made of any length to allow the pumps to be let down into the well 2 to such a point as to be properly operated, and the whole mill, including the pumps, being practically supported upon the disk 19 and the antifrictional bearings 21 and guided by similar bearings at 24 it will be easily turnable in light airs.

By supporting the disk or wheel 14 from the ends of the crank-arms, so that its center is substantially in line with the bearings or crank-shafts 12, I am enabled to dispense with separate supports for this disk and to apply the power from the wind-wheel shaft between the cranks 11.

Having thus described my invention, what I claim, and desire to secure by Letters Patent, is—

1. The combination in a wind-wheel of the wind-wheel shaft, crank-shafts, frictional disks through which power is transmitted from one to the other, standards in which said shafts are journaled, a horizontally-revoluble disk or table to which the standards are fixed and antifrictional bearings for the table and pumps with suction and discharge pipes suspended from said table.

2. The combination in a windmill of a horizontally-revoluble table, a stationary cup and ball or like bearings located within the

cup and upon which the table is supported, pumps having suction and discharge pipes and suspended from said table, standards extending upwardly from the table, a horizontally-revoluble guide through which the standards pass, a ball-carrying cup within which the guide is revoluble, a wind-wheel shaft and crank-shafts journaled in said standards, a centrally-disposed friction-wheel fixed to the cranks with its center unsupported and in line with the crank-shafts, frictional disks mounted upon the wind-wheel shaft and contacting with the crank-carried disk.

3. The combination in a windmill of a ball-bearing horizontally-revoluble table having pumps with suction and discharge pipes suspended therefrom within the well, standards extending upwardly from the table, a ball-bearing guide through which the upper portions of said standards pass and by which they are maintained in position, a wind-wheel shaft journaled across the top of the standards, crank-shafts journaled in line below the wind-wheel shaft, a friction disk or wheel fixed to the ends of the cranks with its center in line with the crank-shaft bearings, a pair of disks movable upon a feather on a wind-wheel shaft having faces adapted to engage the periphery of the crank-wheel, and screws by which said disks are adjustable with relation to the crank-wheel.

4. The combination in a windmill of a ball-

bearing table having standards extending upwardly therefrom, a wind-wheel and crank-shafts journaled in said standards, frictional disks through which motion is transmitted from the wind-wheel shaft to revolve the crank-shafts, pitmen extending from the crank-shafts within the discharge-pipes to the pumps, an annular fixed chamber surrounding the discharge-pipes and out of contact therewith, means for delivering the contents of the discharge-pipes into said chamber, and a conductor leading from the chamber.

5. The combination in a windmill of a horizontally-revoluble ball-bearing table, standards extending upwardly therefrom, a wind-wheel shaft and crank-shafts journaled in said standards, frictional disks by which motion is transmitted from the wind-wheel shafts to revolve the crank-shafts, pumps having suction-pumps below and discharge-pipes above said pipes being fixed to and turnable with the ball-bearing table and frame or yokes to which the discharge and suction pipes are fixed so that the pumps are supported one above the other and overlapping each other as shown.

In witness whereof I have hereunto set my hand.

WINFIELD CURTIS.

Witnesses:

S. H. NOURSE,
JESSIE C. BRODIE.