

(19) **DANMARK**

(10) **DK/EP 3862505 T3**



Patent- og
Varemærkestyrelsen

(12) **Oversættelse af
europæisk patentskrift**

-
- (51) Int.Cl.: **E 04 F 11/18 (2006.01)**
- (45) Oversættelsen bekendtgjort den: **2023-07-24**
- (80) Dato for Den Europæiske Patentmyndigheds bekendtgørelse om meddelelse af patentet: **2023-05-10**
- (86) Europæisk ansøgning nr.: **21150524.3**
- (86) Europæisk indleveringsdag: **2021-01-07**
- (87) Den europæiske ansøgnings publiceringsdag: **2021-08-11**
- (30) Prioritet: **2020-02-06 FI 20205124**
- (84) Designerede stater: **AL AT BE BG CH CY CZ DE DK EE ES FI FR GB GR HR HU IE IS IT LI LT LU LV MC MK MT NL NO PL PT RO RS SE SI SK SM TR**
- (73) Patenthaver: **Lumon Invest Oy, Kaitilankatu 11, 45130 Kouvola, Finland**
- (72) Opfinder: **Hilliaho, Esa, Vehnäpellontie 59 B, Valkeala 45360, Finland**
- (74) Fuldmægtig i Danmark: **Plougmann Vingtoft A/S, Strandvejen 70, 2900 Hellerup, Danmark**
- (54) Benævnelse: **LÅSEANORDNING TIL FASTGØRELSE AF EN KANTLISTE PÅ EN PLADE**
- (56) Fremdragne publikationer:
US-A1- 2012 189 378
US-A1- 2015 007 514
US-B1- 8 863 440

DESCRIPTION

Field of the invention

[0001] The presented solution relates to a locking arrangement. The locking arrangement can be used for locking a panel to an edge strip. The locking arrangement can be applied in a panel system.

[0002] The solution presented also relates to a method for assembling the locking arrangement.

Background of the invention

[0003] Different types of panel systems may be incorporated in buildings, for example, in conjunction with the balcony or terrace of a building. In many cases, a glass panel is made of tempered glass and may comprise several laminated glass layers. A glass panel system typically comprises several glass panels which are preferably placed one after another and which in the closed position constitute a wall.

[0004] A panel system typically comprises an upper guide track and a lower guide track for guiding the travelling of the glass panel, one or more hinge elements and/or guide elements being placed within or on top of the guide tracks and fixed to the panel. The hinge element and/or control element controls the travelling of the panel, or the panel is suspended on the upper guide track by means of them, or the panel rests through them on the lower guide track which supports the panel. Typically, the panel may be movable along the upper and lower guide tracks by means of the said hinge element or guide element. Moving typically takes place manually by pushing.

[0005] The upper and lower guide tracks are normally installed in the horizontal position and fixed, for example, to structures of a building. The lower guide track may be positioned on floor level or higher, for example, on a railing structure. The panel is usually openable sideways and closable.

[0006] Two or more glass panels which are moved to a position in which they can be opened, may be placed next to each other in a bundle in the open position, whereby an open space is formed in the glass panel system, for example for ventilation or passage.

[0007] Some panel systems are disclosed in documents EP 1892362 A1, EP 3138984 A1 and WO 2014/068178 A1.

[0008] A solution for attaching an edge strip to the panel is disclosed in document EP 2119864

A2. Solutions for attaching accessory parts to the edge strip of the panel are disclosed in WO 2007/065972 A1 and EP 2677109 A1.

[0009] Applying the solution, the fastening of the edge strip to the panel should be as easy and reliable as possible. The solution should also allow a compact structure and, if necessary, the use of accessory parts.

[0010] A locking arrangement according to the preamble of claim 1 is disclosed in US 2012/0189378 A1.

Brief summary of the invention

[0011] The locking arrangement according to the presented solution is disclosed in claim 1. The method according to the presented solution is disclosed in claim 13.

[0012] The presented solution is applicable in panel systems presented above. The panel system according to the solution can be installed in a building, for example in connection with a balcony, a terrace, a shelter, or a lean-to. The panel system can also be provided in connection with a terrace, a shelter or a lean-to separate from a building, for example to form wall structures for a roof construction. In an example, the system comprises a number of panels made of glass or a similar material which is particularly transparent.

[0013] The presented solution has the advantage of securing the engagement of a locking groove in a panel with a matching protrusion in a locking element. This is possible because the locking groove and the protrusion are placed against each other even before the locking element and the panel are installed in the edge strip. They are thus visible, unlike in solutions of prior art, in which, firstly, a corresponding panel with its locking groove has to be inserted in the edge strip provided with said protrusion.

[0014] Furthermore, the presented solution has the advantage of allowing the fastening of accessory parts, for example in a compact way or in the vicinity of the panel.

Brief description of the drawings

[0015] The solution presented will be described in greater detail in the following, with reference to the accompanying drawings.

Figure 1 shows a front view of a panel system in which the presented solution can be applied and in which all the panels are closed, parallel, and arranged one after the other.

Figure 2 shows a panel according to an example, in which the presented solution is applied.

Figure 3 shows a locking arrangement according to an example of the presented solution, viewed from the end of the edge strip.

Figure 4 shows the first step of a method according to the presented solution.

Figure 5 shows the second step of the method according to the presented solution.

Figure 6 shows a fastening arrangement according to an example, viewed from the end of the edge strip.

Figure 7 shows a fastening arrangement according to another example.

Fig. 8 shows a fastening arrangement according to a third example.

Fig. 9 shows a fastening arrangement according to a fourth example.

Figure 10 shows a fastening arrangement according to a fifth example.

Detailed description of various embodiments of the invention

[0016] In the figures, the same or corresponding parts are marked with the same reference number.

[0017] In this description, a direction Z is defined, as well as directions X and Y, which are crosswise, preferably orthogonal to it as well as to each other. As shown in Figs. 1 and 2, the directions Z and X can be horizontal, in which case the direction Y is vertical, oriented upwards.

[0018] Figure 1 shows an example of a panel system to which the presented solution may be applied.

[0019] The panel system comprises one or more panels 10, 12. When closed, the panels are preferably parallel and positioned in succession in such a way that they form a wall or window or an access opening.

[0020] The panel system comprises a lower profile 18 and an upper profile 16, which are parallel, spaced from each other and placed on top of each other in the direction Y. The panels 10, 12 are placed between the lower profile 18 and the upper profile 16 in such a way that the panels are parallel with the direction Y. The panels 10, 12 are engaged with the lower profile 18 and the upper profile 16. The two opposite upright edges of the panel 10, 12 are parallel with the direction Y, and the upper and lower edges of the panel are parallel with the direction Z.

[0021] The lower profile 18 is mounted to a railing or a suitable surface, or is embedded in it,

for example in a floor. The upper profile 16 is mounted to, for example, a ceiling or another suitable structure.

[0022] In Fig. 1, the panels 10, 12 are shown in a closed position so that they are parallel with the lower and upper profiles 16, 18.

[0023] According to an example shown in Fig. 1, the panel 10, 12 is stationary or movable along the lower and upper profiles 16, 18. In addition, the panel 10, 12 may be openable so that it pivots about a rotation axis Y1, Y2. The rotation axis Y1, Y2 is perpendicular to the longitudinal directions of the lower and upper profiles 16, 18 which join the direction Z. Said rotation axis Y1 (see panel 12), Y2 (see panel 10) is also located close to one vertical edge of the panel 10, 12.

[0024] The upper and lower edges of the panel 10, 12 may be provided with elements, such as a hinge element 20, 22, 28, and 30 or a guide element 14, which are placed within the upper profile 16 or the lower profile 18 and allow the panel 10, 12 to be opened and/or moved.

[0025] The upper edge of the panel 10, 12 may be provided with an edge strip 26, to which said elements are fastened and by means of which the panel 10, 12 can be engaged with the upper profile 16. Furthermore, the lower edge of the panel 10, 12 may be provided with an edge strip 24, to which said elements are fastened and by means of which the panel 10, 12 can be engaged with the lower profile 18.

[0026] According to an example shown in Fig. 1, the panel 10, 12 may be provided with elements, such as a locking element 36, a wire 34, a chain, a thread, or the like, or a handle element 32, by means of which the panel 10, 12 can be released or locked.

[0027] In the description below, reference numeral 10 will refer to either one of said panels 10 and 12. Correspondingly, in the description below, reference numeral 24 will refer to either one of said edge strips 24 and 26.

[0028] Figure 2 shows an example of a panel 10 which is equipped with an edge strip and to which the solution presented may be applied.

[0029] When the panel 10 is provided with edge strips 24 at the upper and lower edges, said panel 10 can be applied in a panel system according to Fig. 1.

[0030] In another example, the panel 10 only comprises one edge strip, for example the edge strip 24 at the upper edge of the panel. Said panel can thus be utilized in a panel system which only comprises the above-described upper profile 16, to which the panel 10 is connected and along which the panel 10 is movable. In such a case, the panel 10 is, for example, not openable in the above-described way.

[0031] Figure 3 shows a locking arrangement according to the presented solution. Said

solution can be applied in the panel 10 of Figs. 1 and 2 as well as in the above-presented panel 10 with only one edge strip 24 at the upper or lower edge of the panel.

[0032] The locking arrangement according to the presented solution comprises a panel 10 equipped with a locking groove 80, and an edge strip 24 as well as a locking element 40.

[0033] According to an example shown in Fig. 3, the panel 10 comprises two parallel side faces 76, 78 delimited by a straight edge 84 of the panel. Normally, a total of four straight edges are provided, forming a rectangular railing panel 10. Preferably, the angle between each side face 76, 78 and the straight edge 84 is bevelled.

[0034] The panel 10 comprises at least one locking groove 80 provided in one of the side faces 76, 78, for example in the side face 78, as shown in Fig. 3. The locking groove 80 is parallel with the above-mentioned straight edge 84. The locking groove 80 is spaced from the straight edge 84 and preferably extends across the entire side face 78 to its both edges. The locking groove 80 may be U-shaped. The side face 76 on the opposite side of the panel 10 is preferably even.

[0035] Using the locking groove 80, it is simpler to install and lock the panel 10 to the edge strip 24.

[0036] According to an example shown in Fig. 3, the edge strip 24 comprises an open groove which faces upwards when the edge strip 24 is in the use position and fastened to the lower edge of the panel 10. Said groove faces downwards when the edge strip 24 is in its use position and fastened to the upper edge of the panel 10. The edge of the panel 10 is inserted in said open groove. The edge strip 24 and its longitudinal direction are parallel with the direction Z.

[0037] For fastening e.g. hinge elements 20, 22, 28, 30 and/or guide elements 14, the edge strip 16 may comprise a groove 56 which is open in an opposite direction with respect to said open groove for the panel 10.

[0038] According to an example shown in Fig. 3, the edge strip 24 comprises at least two opposite side walls 58, 60 and a bottom wall 62 which delimit and constitute said open groove in which the locking element 40 and the panel 10 can be installed. According to an example, as shown in Figs. 3 and 10, the side walls 58, 60 and the bottom wall 62 are seamless, integral parts of the edge strip 24. Each side wall 58, 60 is placed on one side of the panel 10 and may consist of several parts which are, for example, fastened to the bottom wall 62. Simultaneously, each side wall 58, 60 constitutes, for example, part of the outer face of the edge strip 24, in combination with the locking element 40, if necessary.

[0039] Said open groove may resemble, for example, the shape of a U. The side wall 58, 60 or the bottom wall 62 may comprise forms 64, 66, 68, 70, 72, 74 which are, for example, protrusions or grooves. Said protrusions or grooves may delimit a space which forms said U

shape. Said protrusions or grooves may be placed against the locking element 40 or the panel 10, for example against the side face 76 of the panel 10 or the side face 50 of the locking element 40, and fix the position of the locking element 40 and the panel 10.

[0040] Preferably, the locking groove 80 of the installed panel 10 is inserted in said open groove.

[0041] According to an example shown in Fig. 3, the locking element 40 is a separate, stand-alone component which is inserted in the open groove of the edge strip 24, adjacent to the panel 10. In the direction X, the locking element 40 is between one side wall 60 of the edge strip 24 and the panel 10, 12. At least part of the locking element 40 or its length, or all of it, is placed in said space.

[0042] According to an example shown in Fig. 3, the locking element 40 comprises a body 54 with a first end 44 and an opposite second end 46. The body 54 comprises two side faces 50 and 52, of which the first side face 52 is placed against one side face 78 of the panel, and the other side face 50 is placed against one side wall 60 of the edge strip 24, 26, as shown in Fig. 3.

[0043] The first end 44 extends towards the bottom wall 62, and in an example it may also extend between the bottom wall 62 and the panel 10 in the transverse direction so that it is between the bottom wall 62 and the straight edge 84 of the panel 10, seen in the direction Y. The first end 44 may thus be placed against the straight edge 84. Consequently, the panel 10 can be used to push the locking element 40 and the end 44 into the edge strip 24 when the panel 10 is being installed.

[0044] According to an example shown in Fig. 3, the body 54 and the end 44 together constitute the shape of an L.

[0045] According to an example shown in Fig. 3, the second end 46 extends towards the opening formed by the open groove of the edge strip 24, wherein the end 46 can be fitted between the side wall 60 of the edge strip 24, 26 and the side face 78 of the panel 10, 12. In this way, the body 54 and the end 44 together form, for example, the shape of an I.

[0046] According to an example and Fig. 10, the locking element 40 may also extend beyond said opening, extending e.g. sideways or away from the side face 78 and, if necessary, also towards the bottom wall 62. Thus, the body 54 and the end 44 together form the shape of, for example, an L, a J, or a U.

[0047] According to Fig. 3, one side face 52 of the locking element 40 is provided with a protrusion 42 which is fitted in the locking groove 80 when the panel 10 is installed in the edge strip 24. The protrusion 42 is inside said open groove when the locking element 40 is fitted in said open groove.

[0048] The protrusion 42 is a bulge, a step, a stop, a tooth, or a cog on the side face 52 which - when fitted in the locking groove 80 - has the function of preventing the detachment of the panel 10 from the edge strip 24 when it is subjected to forces. In particular, the purpose is to prevent the movement of the panel 10 in the direction Y, away and apart from the edge strip 24. It is necessary for the locking element 40 to remain in place in the edge strip 24.

[0049] For the panel 10 and the locking element 40 to be insertable together and simultaneously in the edge strip 24, the width of the open groove of the edge strip 24 has to be designed wider than the panel 10, particularly in the direction X. During the insertion, the panel 10 moves in a direction opposite to the direction Y.

[0050] Said width also accommodates for the insertability of the panel 10 in the edge strip 24 in such a way that the panel 10 and the locking element 40 are together and abutting each other so that the protrusion 42 is fitted in the locking groove 80. Said width is also adjusted to prevent or delimit the movement of the panel 10 and the locking element 40 in the direction X when they are fitted in the edge strip 24. In particular, said width is adjusted to prevent the locking element 40 from withdrawing in the direction X so far from the panel 10 that the protrusion 42 would come off the locking groove 80.

[0051] After this, the above-described function of the locking groove 80 to prevent the detachment of the panel 10 is possible. However, it is also required that the locking element 40 is simultaneously locked within the edge strip 24 and its movement in the direction Y, away and apart from the edge strip 24, is prevented.

[0052] According to examples shown in Figs 3 and 10, for said locking of the locking element 40, a form 64 is provided in the side wall 60 or the bottom wall 62. The form 64 is a protrusion, for example a bulge, a step, a stop, a tooth, or a cog, or alternatively a groove, which may be U-shaped, in the side or bottom wall 60, 62. The form 64 is, for example, provided at the opening constituted by the open groove of the edge strip 24, as shown in Fig. 3. Preferably, the form 64 is a seamless, integral part of the side or bottom wall 60, 62.

[0053] Furthermore, the locking element 40, for example its side wall 50, is provided with a form 48 against which the form 64 is fitted when the locking element 40 and the panel 10 are installed in the edge strip 24. The form 48 is a protrusion in the locking element 40, for example a bulge, a step, a stop, a tooth, or a cog, or alternatively a groove which may be U-shaped. Preferably, the form 48 is a seamless, integral part of the locking element 40.

[0054] When placed against the matching form 48, the form 64 has the function of preventing the simultaneous detachment of the locking element 40 and the panel 10 from the edge strip 24 when it is subjected to forces. In particular, the purpose is to prevent the locking element 40 from moving in the direction Y, away and apart from the edge strip 24.

[0055] The forms 48 and 64 can be selected more specifically by, for example, experimenting so that they do not come apart or do not force the side or bottom wall 60, 62 to bend and

cause detachment of the locking element 40 when subjected to minor or ordinary forces encountered under normal conditions of use.

[0056] According to an example of the solution shown in Fig. 3, the locking element 40 is at least partly wedge-shaped so that its cross section in the direction X tapers when viewed in a direction towards the bottom wall 62, opposite to the direction Y. The side faces 50 and 52 are thus inclined with respect to each other. The wedge-shaped structure facilitates the insertion of the locking element 40 together with the panel 10, 12 into the edge strip 24, 26. For example in the situation of Fig. 3, the inclined side face 50 will thus slide along the form 64 and simultaneously force the side wall 60 to give way until the form 48 is engaged with the form 64 and the side wall 60 can re-assume its position.

[0057] According to an example of the presented solution, the straight edge 84 of the panel 10 is fastened to the bottom wall 62 of the edge strip 24 by means of an adhesive. The function of the adhesive is to prevent the movement of the panel 10 in the direction Z along the edge strip 24 and its bottom wall 62 when these are subjected to forces.

[0058] The method according to the presented solution for fastening the edge strip 24 to the panel 10 is implemented as follows. Said method applies the locking arrangement according to the above-presented solution for fastening the edge strip 24 to the panel 10.

[0059] In the first step of the method, as shown in the example of Fig. 4, the locking element 40 is placed against the panel 10 so that the protrusion 42 of the locking element 40 is received in the locking groove 80 of the panel 10. This is done, for example, by placing the side face 52 against the side wall 78 and, if necessary, by placing the first end 44 against the straight edge 84.

[0060] In the next, second step, as shown in the example of Fig. 5, the locking element 40 and the panel 10 are together inserted in the edge strip 24, in its open groove, for example by a movement opposite to the direction Y. The locking element 40 is thus placed between the panel 10 and one side wall 60 of the edge strip 24.

[0061] In the next, third step, the locking element 40 and the panel 10 are together plunged into the open groove so that the form 48 of the locking element 40 is received by the form 64 of the edge strip 24.

[0062] In an example, if the locking element 40 is wedge-shaped as presented above, the inclined side face 50 is placed against the side wall 60, for example against the form 64, in said second step. Thus, in the third step of the method, the inclined side face 50 is slid along the side wall 60 or the form 64, simultaneously forcing the side wall 60 to give way in the direction X until the form 48 is received by the form 64 and the side wall 60 can re-assume its position.

[0063] After the presented third step, the locking element 40 and the panel 10 are placed in the edge strip 24, as shown in Fig. 3 or 10. The above description of the locking arrangement

according to the presented solution applies to the examples of these Figs. 3 and 10, and their function.

[0064] In an example, before or after the first step, an adhesive is applied onto the bottom wall 62 of the edge strip 24, to which the straight edge 84 of the panel 10 will adhere in the third step.

[0065] According to an example shown in Fig. 3, at the opening formed by the open groove of the edge strip 24, the locking element is placed between the side wall 60 of the edge strip 24 and the side face 78 of the panel 10. At said opening, the side wall 60 extends towards the side face 78. According to another example shown in Fig. 10, at the opening formed by the open groove of the edge strip 24, the locking element 40 extends away from the side face 78.

[0066] In an example, the side wall 60 or the locking element 40, or their combination, constitutes an upper surface at said opening, next to the panel 10, 12, the upper surface being transverse to the side face 78 of the panel. Correspondingly, the side wall 58 may constitute an upper surface at said opening, next to the panel 10, the upper surface being transverse to the side face 76 of the panel. The section of the side wall 58, 60 or of the locking element 40, left between said upper surface and the bottom wall 62, may be substantially parallel with the side faces 76, 78.

[0067] Figure 6 shows an edge strip 24 equipped with a fastening groove 100.

[0068] The fastening groove 100 makes it possible to fasten accessory parts, such as a sunshade screen, to the edge strip 24. For example, a means for fastening the sunshade screen can be placed in said fastening groove 100.

[0069] Said fastening groove 100 can be applied in the panel 10 of Figs. 1 and 2 as well as in the above presented panel 10 with only one edge strip 24 at the upper or lower edge of the panel. Said fastening groove 100 can also be applied in the above presented arrangement, shown e.g. in Fig. 3 or in Fig. 10, for fastening the edge strip 24 to the panel 10.

[0070] In another example, the fastening groove 100 is applied in the edge strip 24 to which the panel 10 is fastened. In a third example, said panel 10 is also equipped with a locking groove 80, as presented above. In a fourth example, said edge strip 24 is further equipped with a locking element 40, as presented above.

[0071] We shall discuss these examples jointly in the following.

[0072] According to an example shown in Fig. 6, the fastening groove 100 is provided next to the side wall 60, adjacent to its outer face, for example next to the upper surface formed by said side wall 60.

[0073] According to an example shown in Fig. 7, the fastening groove 100 is provided in the

side wall 60, on its outer face, for example on the upper face of the side wall 60. According to another example shown in Fig. 8 or Fig. 9, the fastening groove 100 is provided in the side wall 58, on its outer face, for example on the upper surface formed by the side wall 58.

[0074] According to an example shown in Fig. 10, the fastening groove 100 is provided in the locking element 40, on its outer face, for example on the upper surface formed by the locking element 40. This makes it possible to use fastening grooves of various types or different positions, because the locking element can be replaced with a different one.

[0075] The fastening groove 100 extends continuously in the longitudinal direction of the edge strip 24, in the direction Z, forming a groove-shaped structure.

[0076] The fastening groove 100 is accessible from the outside of the panel 10, for example from the direction Y in the use position of Fig. 6, or from a direction opposite to the direction Y, depending on whether the edge strip 24 is installed in the lower edge of the panel 10, as shown in Fig. 3, or in the upper edge of the panel 10, as shown in Fig. 2.

[0077] In an example, the fastening groove 100, namely its first section 102, first extends from the outer face of the edge strip 24 towards its inner part, and the first section 102 is followed by a second section 104, after which the fastening groove bends or curves in a direction transverse to the section 102. In an example, the first section 102 extends towards the panel 10, and the second section 104 extends towards the bottom wall 62. In an example shown in Figs. 6 and 10, the first section 102 extends towards the bottom wall 62, and the second section 104 extends away from the panel 10.

[0078] In an example shown in Figs. 6 and 10, the first section 102 extends from the above-mentioned upper surface towards the bottom wall 62, and the second section 104 extends away from the panel 10 which is installed in the edge strip 24, for example in the direction X. The second section 104 extends, within the side wall 60 or the locking element 40, away from the side face 78, in a direction transverse to it. The second section 104, when in the side wall 58, extends, within the side wall 58, away from the side face 76, in a direction transverse to it.

[0079] In an example, the fastening groove 100 is L-shaped, J-shaped or curved, whereby a compact structure is achieved.

[0080] In an example, the second section 104 is designed so that part of the side wall 58, 60 will be left between the outer surface or said upper surface and the second section 104. Said part of the side wall 58, 60 constitutes a cover or a protrusion extending above the second section 104, as shown in Figs. 6 to 10. Said fastening member can be supported below said cover or protrusion.

[0081] The above-mentioned outer face or upper surface of the side wall 58, 60 is provided with an opening of the first section 102, via which the fastening groove 100 is accessible.

[0082] According to the first alternative, the outer or upper surface of the side wall 58, 60 delimits the fastening groove 100 and its opening, at its both edges, as shown in Figs. 7, 8 and 9.

[0083] In the above-presented examples applying the fastening groove 100, an alternative panel may be used, which corresponds to the above-presented panel 10 and its different examples in other respects but does not have a locking groove 80, whereby the side face 78 is, for example, even. Alternatively, a corresponding locking groove is provided in the side face 76. Thus, the side wall 58 may comprise a form, for example a form 66, 68, 70, which is for example a protrusion. Said form is inserted in the locking groove of the panel 10 and prevents the panel 10 from coming off the edge strip 24.

[0084] Furthermore, in the above-presented examples applying the fastening groove 100, an alternative locking element may be used, which corresponds to the above-presented locking element 40 and its various examples in other respects but does not have a protrusion 42, whereby the side face 52 is, for example, even. Said locking element is used, for example, for forcing the panel 10 against the above-presented form.

[0085] Furthermore, in the above-presented examples applying the fastening groove 100, an alternative edge strip may be used, which corresponds to the above-presented edge strip 24 and its various examples in other respects but does not apply the above-presented locking element 40. One example is shown in Fig. 9. In this case, the panel 10 is installed in the open groove of the edge strip 24 without a locking element 40. Thus, the forms of the side walls 58, 60 can also be placed against the side face 78. The above-described locking groove may be applied.

[0086] In the above-presented first alternative, the locking element 40 is separate from the locking groove 100, as shown in the example of Fig. 7 or 8, when the locking element 40 is also applied in the solution.

[0087] According to another alternative, the locking groove 100 is between the side wall 60 and the locking element 40, as shown in the example of Fig. 6. In this second alternative, for example the side wall 60, for example its outer or upper surface, delimits the fastening groove 100 and its opening, at its one edge, and the above-presented locking element 40 delimits the fastening groove 100 and its opening at its opposite, second edge.

[0088] In an example, the form 64 of the edge strip 24 delimits the fastening groove 100 or constitutes the bottom of the fastening groove 100, at least in part. Furthermore, in an example, the end 46 of the locking element 40 may delimit the fastening groove 100 and be placed between the fastening groove 100 and the panel 10.

[0089] Considering the above-presented fastening groove 100 a solution of its own, that is, a fastening arrangement for accessory parts, the fastening arrangement comprises, first of all, the edge strip 24 with opposite side walls 58, 60 and a bottom wall 62, forming an open

groove, in which the straight edge 84 of the panel 10 can be installed. Secondly, it comprises the fastening groove 100 for accessory parts, the fastening groove 100 being provided in the side wall 58 or 60, for example in said upper surface.

[0090] In one alternative, the fastening arrangement according to this solution further comprises a locking element 40 inserted in the open groove of the edge strip 24, the locking element 40 being placed between one side wall 60 of the edge strip 24 and the panel 10 to be installed. In this alternative, the fastening groove 100 may be provided between said side wall 60 and the locking element 40.

[0091] In one alternative, the fastening arrangement according to this solution further comprises a panel 10 with two parallel side faces 76 and 78 delimited by the straight edge 84 of the panel 10.

[0092] In this solution of the fastening arrangement, it is possible to apply the above described fastening grooves 100 and/or edge strips 24 and/or panels 10 and/or locking elements 40.

[0093] The upper profile 16 and/or the lower profile 18, or the edge strip 24, and/or the locking element 40 are, in an example, made of aluminium or an aluminium alloy, and have a continuous or elongated shape, the longitudinal direction being parallel with the direction Z. It is possible to use other materials and metals as well.

[0094] The hinge element 20, 22, 28 or 30, or the guide element 14 is preferably a piece made of plastic material, but other materials, such as metal, may also be used.

[0095] The panel 10 is made of e.g. glass, according to one example, tempered glass. The panel made of glass may be a laminated structure. Other glass materials may be used as well. The panel 10 is preferably transparent, but opaque panels can also be used.

[0096] The solutions presented are not limited merely to the examples shown in the accompanying figures or specifically disclosed in the foregoing description, or to which reference has been made in the description. The different embodiments of the presented solution are disclosed in the accompanying claims.

REFERENCES CITED IN THE DESCRIPTION

Cited references

This list of references cited by the applicant is for the reader's convenience only. It does not form part of the European patent document. Even though great care has been taken in

compiling the references, errors or omissions cannot be excluded and the EPO disclaims all liability in this regard.

Patent documents cited in the description

- [EP1892362A1 \[0007\]](#)
- [EP3138984A1 \[0007\]](#)
- [WO2014068178A1 \[0007\]](#)
- [EP2119864A2 \[0008\]](#)
- [WO2007065972A1 \[0008\]](#)
- [EP2677109A1 \[0008\]](#)
- [US20120189378A1 \[0010\]](#)

Patentkrav**1. Låseanordning omfattende**

- (i.) en plade (10, 12) med
 - 5 - to parallelle sideflader (76, 78) afgrænset af en lige kant (84) af pladen, og
 - en låserille (80) tilvejebragt i en af sidefladerne og parallelt med den lige kant og en første retning (Z);
 - (ii.) en kantliste (24, 26) med
 - 10 - modstående sidevægge (58, 60) og en bundvæg (62), som udgør en åben rille, i hvilken åbne rille pladens lige kant (84) er installeret, og
 - en første form (64) tilvejebragt i en af sidevæggene; og
 - (iii.) et låseelement (40) med to sideflader (50, 52) og indsat i kantlistens (24, 26) åbne rille, idet låseelementet (40) er placeret i det mindste delvist eller helt mellem pladen (10, 12) og en af sidevæggene (60) af kantlisten,
 - hvor låseelementet (40) omfatter:
 - 15 - en anden form (48) tilvejebragt i en af sidefladerne (50) af låseelementet, idet den anden form passer til og er placeret mod
 - 20 den første form (64) af kantlisten, idet den anden form (48) er konfigureret at forhindre låseelementet (40) i at løsne sig fra kantlisten (24, 26) og i at bevæge sig i den anden retning (Y);
- kendetegnet ved, at** låseelementet (40) yderligere omfatter:
- 25 - et fremspring (42) dannet i en af sidefladerne (52) af låseelementet og indsat i pladens låserille (80), idet fremspringet er konfigureret til at forhindre pladen (10, 12) i at løsne sig fra kantlisten (24, 26) og i at bevæge sig i en anden retning (Y), som er på tværs af den første retning (Z).

- 30 **2.** Låseanordningen ifølge krav 1, hvor bredden af kantlistens (24, 26) åbne rille i en tredje retning (X) er konfigureret til at svare til samlingsbredden af pladen (10, 12) og låseelementet (40) for at forhindre eller begrænse pladen (10, 12) og/eller låseelementet (40) i at bevæge sig i den tredje retning (X) inden for kantlisten (24, 26), for at forhindre fremspringet (42) af låseelementet i at blive løsnet fra

pladens (10, 12) låserille (80), og hvor den tredje retning (X) er på tværs af både den første retning (Z) og den anden retning (Y).

3. Låseanordningen ifølge krav 1 eller 2, hvor pladens lige kant (84) er fastgjort til bundvæggen (62) af kantlisten ved hjælp af et klæbemiddel for at forhindre pladen (10, 12) i at bevæge sig i den første retning (Z) langs kantlisten (24, 26).

4. Låseanordningen ifølge et hvilket som helst af kravene 1 til 3, hvor den første form (64) af kantlisten er et fremspring eller en rille, og/eller den anden form (48) af låseelementet er et fremspring eller en rille, der passer til den første form (64) af kantlisten.

5. Låseanordningen ifølge et hvilket som helst af kravene 1 til 4, hvor fremspringet (42) af låseelementet er tilvejebragt på en modsat side af låseelementet (40) i forhold til den anden form (48) af låseelementet.

6. Låseanordningen ifølge et hvilket som helst af kravene 1 til 5, hvor låseelementet (40) er i det mindste delvist eller helt kileformet.

7. Låseanordningen ifølge et hvilket som helst af kravene 1 til 6, hvor låseelementet (40) omfatter et legeme (54) med en første ende (44), som først strækker sig mod bundvæggen (62) og derefter strækker sig i en lateral retning mellem bundvæggen (62) og den lige kant (84) af pladen (10, 12).

8. Låseanordningen ifølge et hvilket som helst af kravene 1 til 7, hvor kantlisten (24, 26) er forsynet med en fastgørelsesrille (100) til tilbehørsdele, idet fastgørelsesrillen (100) er anbragt mellem låseelementet (40) og en af sidevæggene (60) af kantlisten.

9. Låseanordningen ifølge krav 8, hvor den ene sidevæg (60) af kantlisten udgør en øvre overflade ved siden af pladen (10, 12), idet den øvre overflade er på tværs af en af sidefladerne (78) af pladen, og hvor fastgørelsesrillen (100) støder op til den øvre overflade.

10. Låseanordningen ifølge et hvilket som helst af kravene 1 til 7, hvor låseelementet (40) og/eller en af sidevæggene (58, 60) af kantlisten udgør en øvre overflade ved siden af pladen (10, 12), idet den øvre overflade er på tværs af en af sidefladerne (76, 78) af pladen, og hvor den øvre overflade er forsynet med en fastgørelsesrille (100) til tilbehørsdele.

11. Låseanordningen ifølge et hvilket som helst af kravene 8 til 10, hvor fastgørelsesrillen (100) omfatter:

- 10 - en første sektion (102), der strækker sig fra en ydre flade af kantlisten (24, 26) mod det indre af kantlisten (24, 26), og
- en anden sektion (104), der danner en forlængelse af den første sektion (102) og bøjer eller buer i en tværgående retning i forhold til den første sektion (102).

15 **12.** Pladesystem omfattende:

- en nedre profil (18) og/eller en øvre profil (16), hvortil mindst en plade (10, 12) er forbundet, hvor en låseanordning ifølge et hvilket som helst af kravene 1 til 11 er påført.

20 **13.** Fremgangsmåde til samling af en låseanordning ifølge et hvilket som helst af kravene 1 til 11, hvor fremgangsmåden omfatter:

- i et første trin at placere låseelementet (40) mod pladen (10, 12), således at fremspringet (42) af låseelementet indsættes i pladens låserille (80),
- i et andet trin at indsætte låseelementet (40) og den lige kant (84) af pladen (10, 12) sammen i kantlistens (24, 26) åbne rille, således at 25 låseelementet (40) er i det mindste delvist eller helt placeret mellem pladen (10, 12) og den ene sidevæg (60) af kantlisten, og
- i et tredje trin at nedsænke låseelementet (40) og pladen (10, 12) i den åbne rille, således at den anden form (48) af låseelementet modtages af 30 den første form (64) af kantlisten.

14. Fremgangsmåden ifølge krav 13, hvor låseelementet (40) og pladen (10, 12) sammen indsættes i kantlistens (24, 26) åbne rille ved en bevægelse i en retning modsat den anden retning (Y).

15. Fremgangsmåden ifølge krav 13 eller 14, hvor låseelementet (40) er i det mindste delvist eller helt kileformet og omfatter en første af sidefladerne (52), som er placeret mod en af sidefladerne (78) af pladen (10, 12) og en modstående, skrånende anden af sidefladerne (50), som er placeret mod en af sidevæggene (60) af kantlisten (24, 26), og hvor fremgangsmåden i det tredje trin omfatter:

- at glide den anden sideflade (50) langs den ene sidevæg (60) af kantlisten og samtidig at tvinge den ene sidevæg (60) til at give efter, indtil den anden form (48) af låseelementet modtages af den første form (64) af kantlisten, og samtidigt antager den ene sidevæg (60) sin position.

DRAWINGS

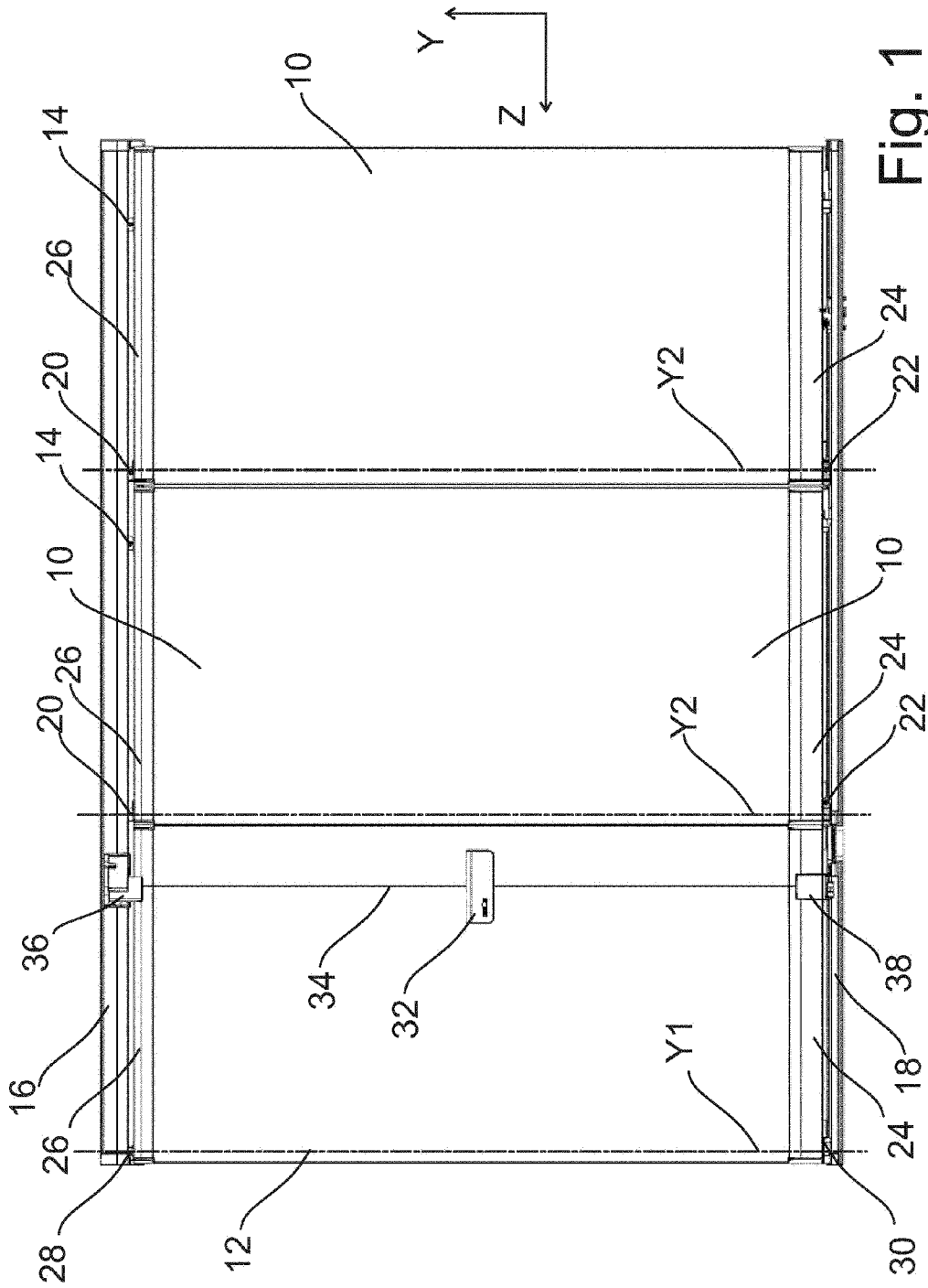
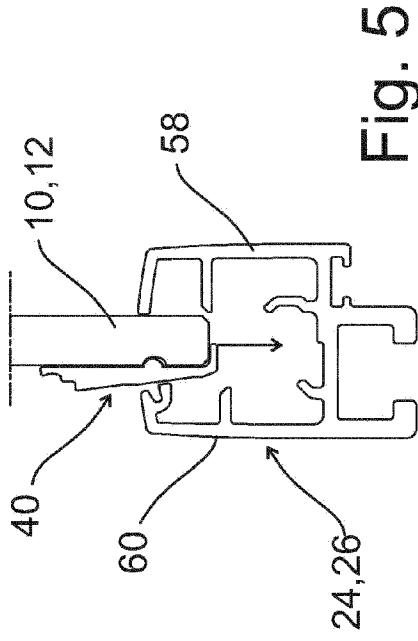
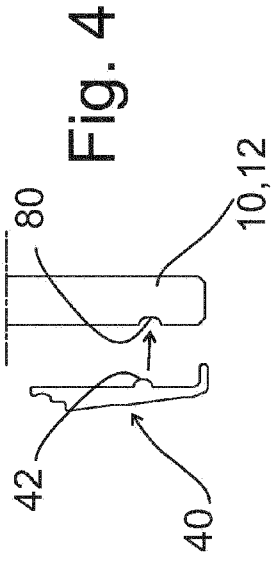
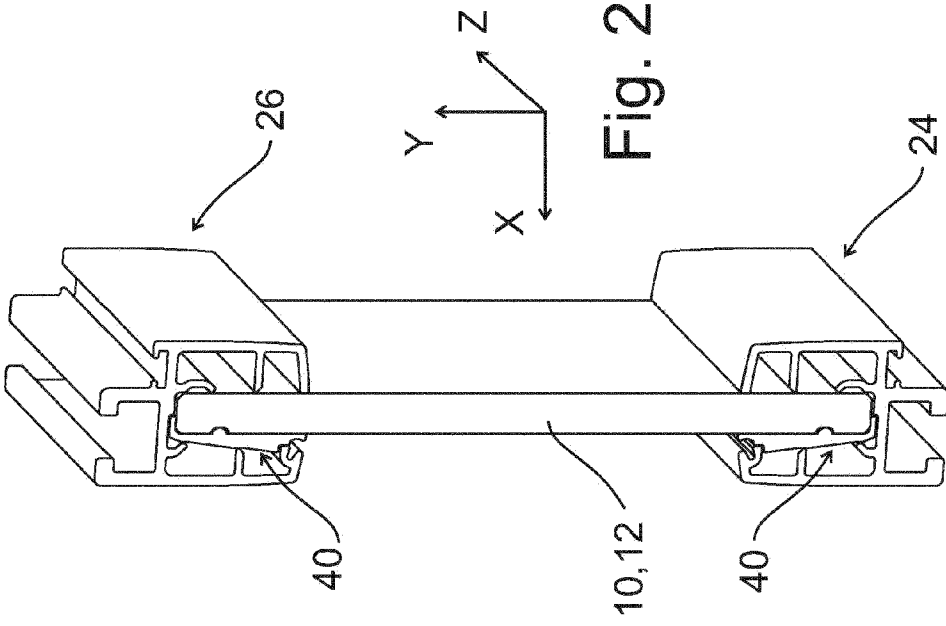

Fig. 1



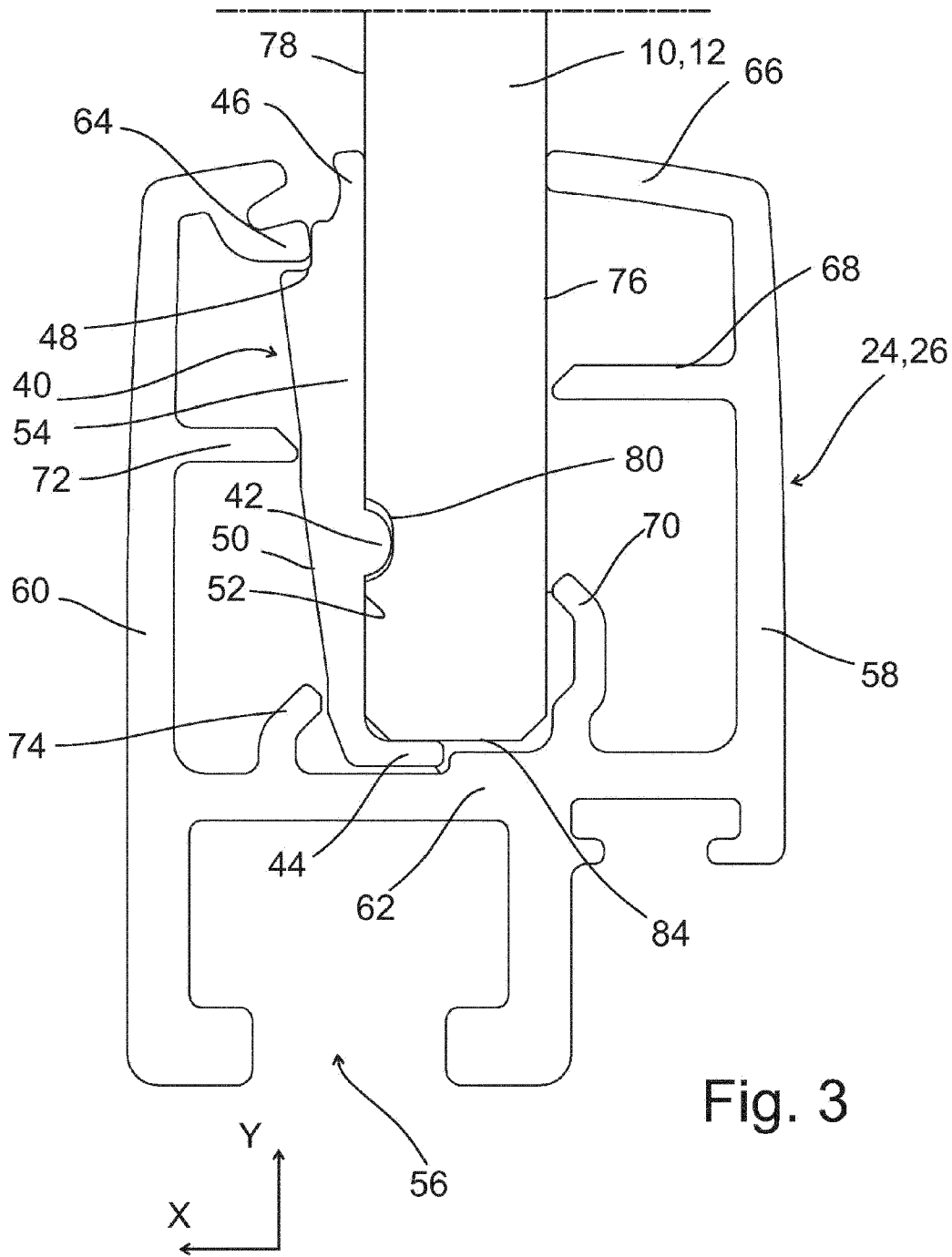

Fig. 3

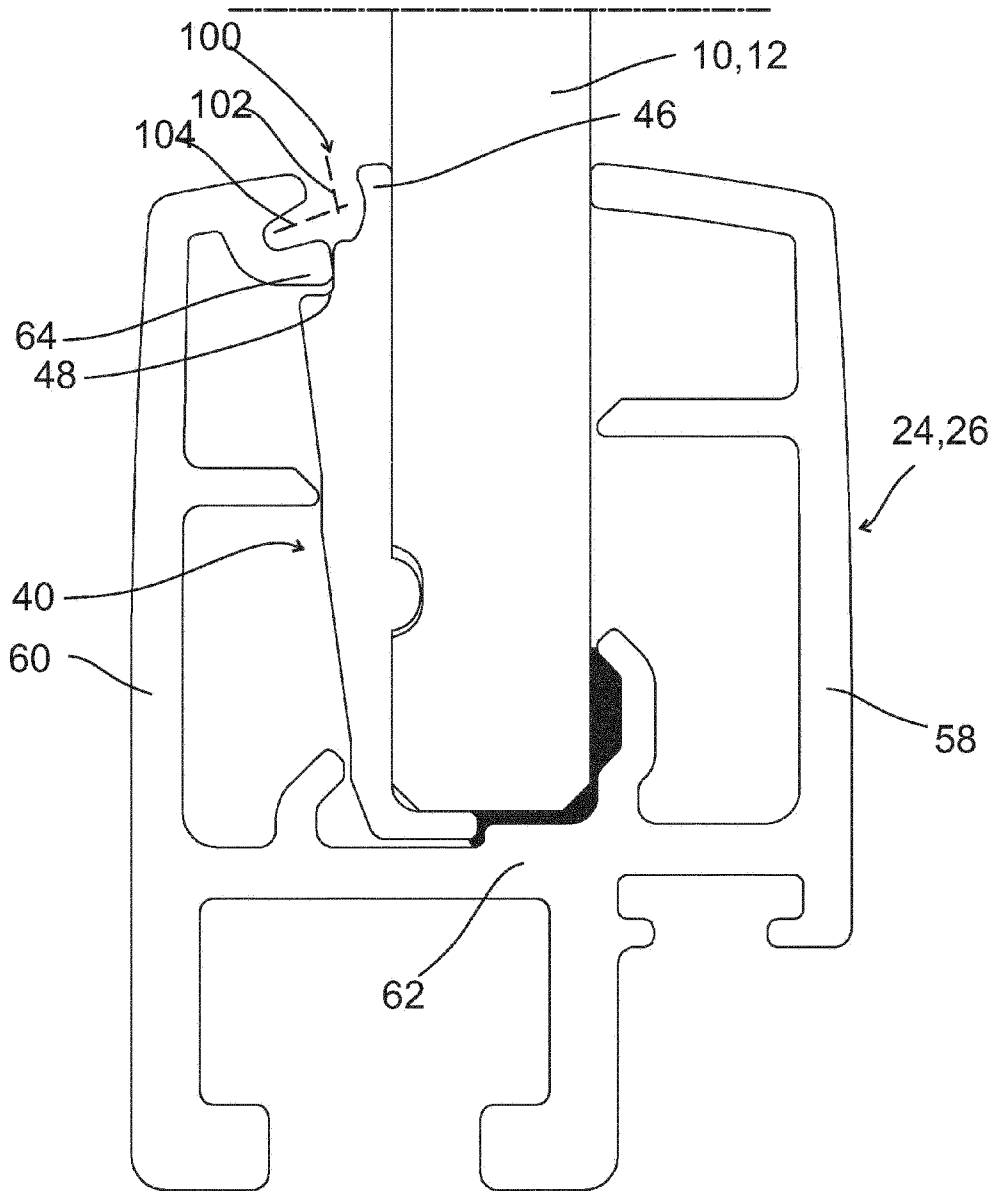

Fig. 6

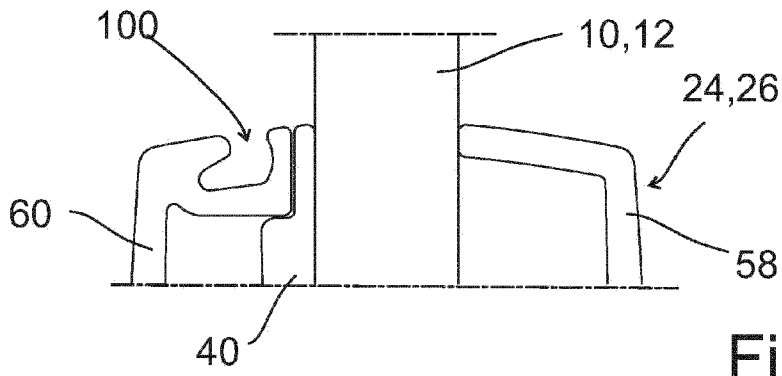

Fig. 7

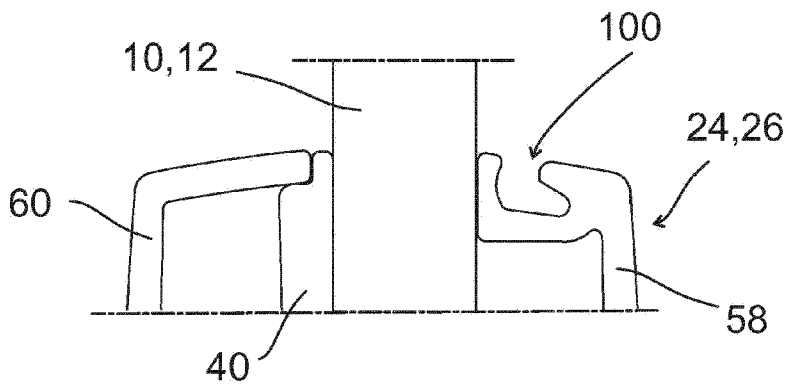

Fig. 8

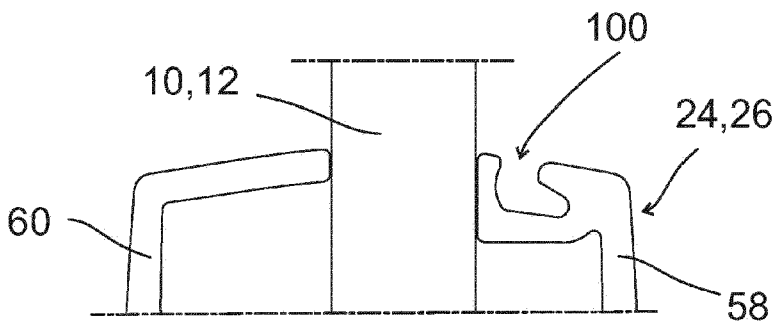

Fig. 9

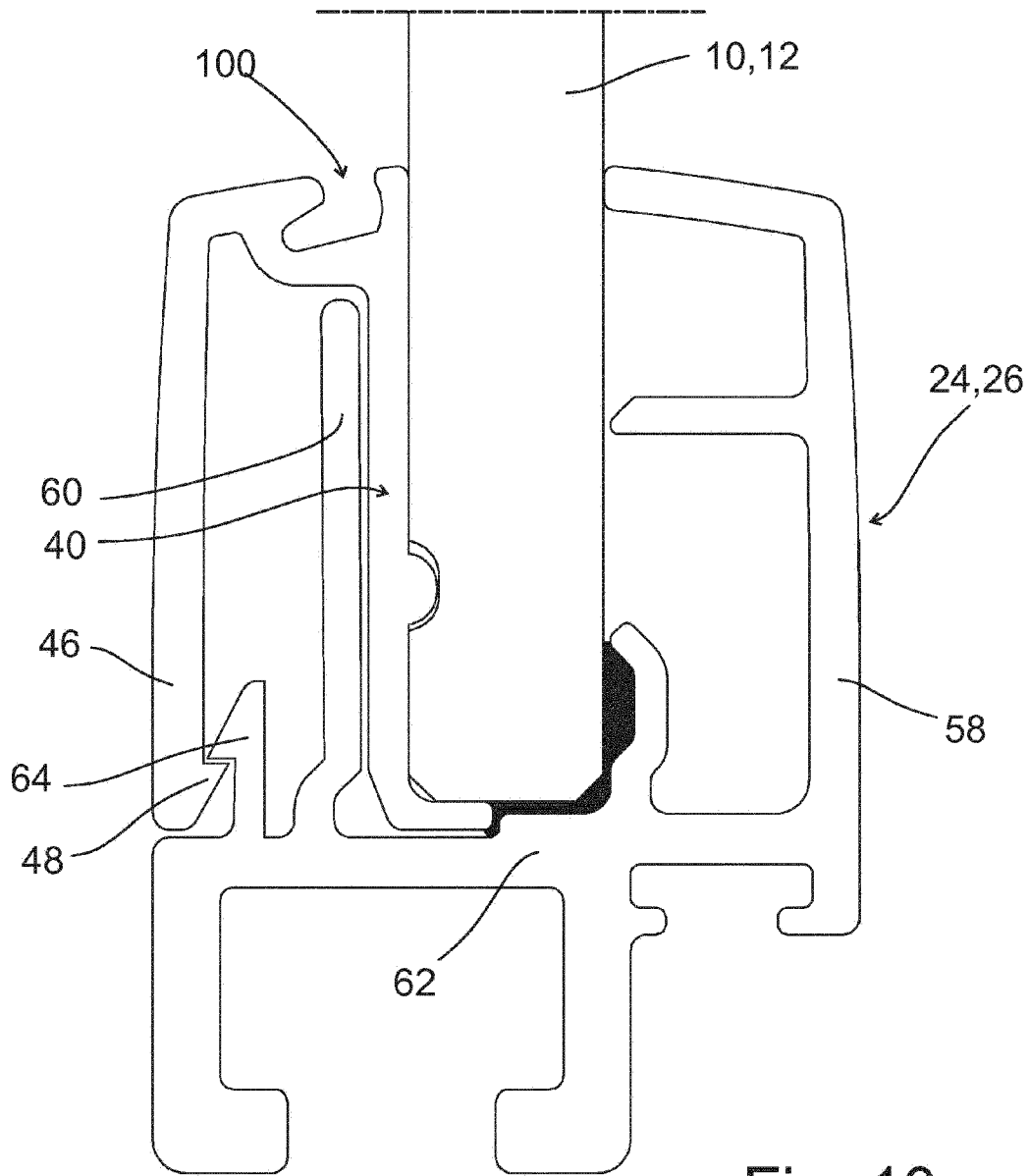

Fig. 10