

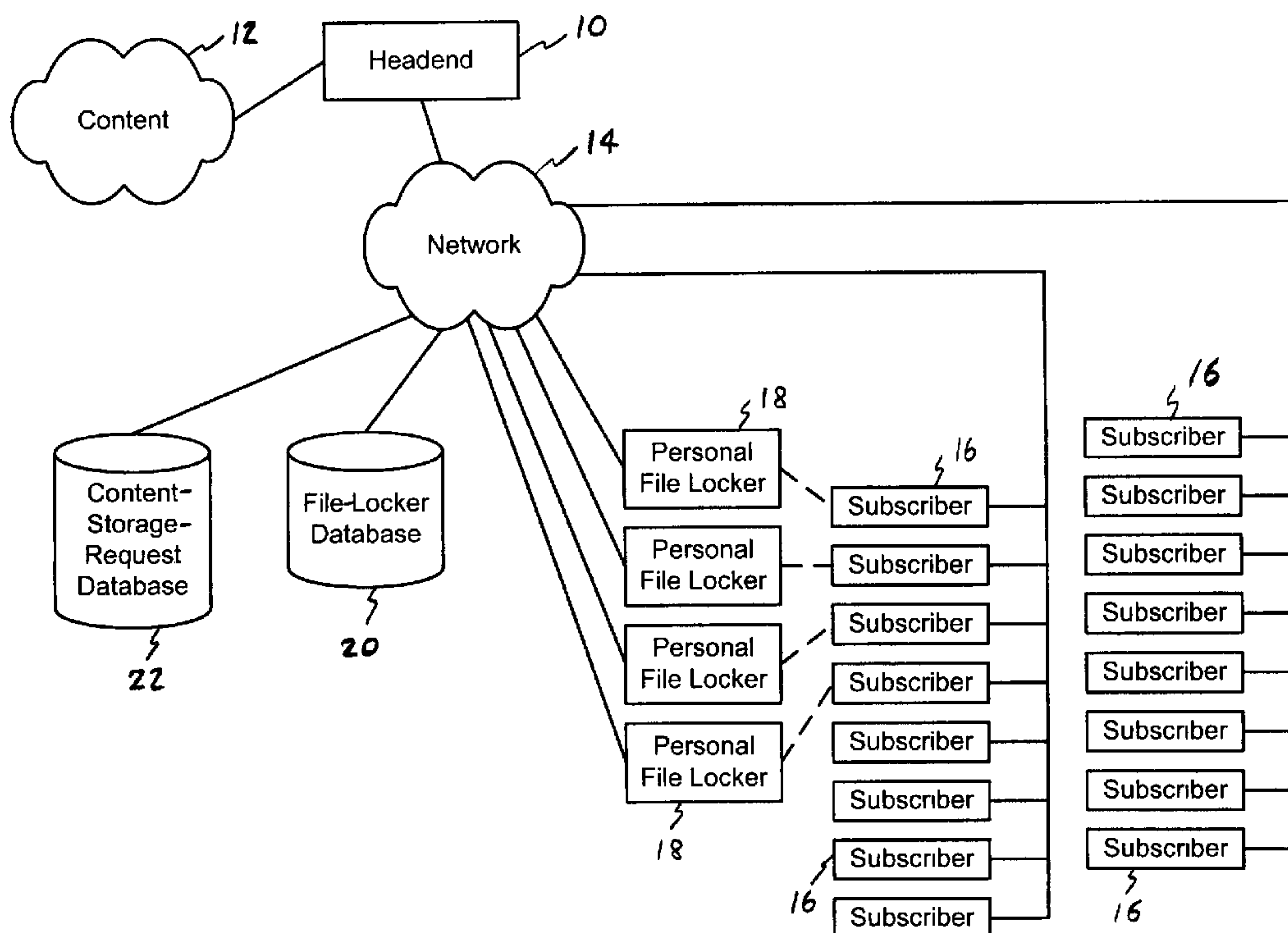

(86) Date de dépôt PCT/PCT Filing Date: 2005/02/16
 (87) Date publication PCT/PCT Publication Date: 2005/10/13
 (85) Entrée phase nationale/National Entry: 2006/09/21
 (86) N° demande PCT/PCT Application No.: US 2005/004832
 (87) N° publication PCT/PCT Publication No.: 2005/094419
 (30) Priorité/Priority: 2004/03/22 (US10/806,251)

(51) Cl.Int./Int.Cl. *H04N 5/76* (2006.01),
G06F 17/30 (2006.01), *H04N 5/7617* (2006.01),
H04N 5/765 (2006.01), *H04N 7/16* (2006.01)
 (71) Demandeur/Applicant:
 COMCAST CABLE HOLDINGS, LLC, US
 (72) Inventeur/Inventor:
 COMPTON, CHARLES L., US
 (74) Agent: BORDEN LADNER GERVAIS LLP

(54) Titre : PROCEDE ET SYSTEME DE STOCKAGE DE CONTENU
 (54) Title: CONTENT STORAGE METHOD AND SYSTEM



(57) Abrégé/Abstract:

A content storage method and system for use in a content distribution network are provided. A personal file locker is established on the network for a user. A content-storage-request database is established. The database tracks requests by the user for placing video programs into the user's file locker for personal use by the user. Upon the broadcasting of a video program for which there exists a request by the user to place the video program into the user's file locker, the requested video program is stored in the user's file locker. The stored video program is then made available to the user for viewing. Alternative approaches to content storage methods and systems are also described.

**Declarations under Rule 4.17:**

- *as to applicant's entitlement to apply for and be granted a patent (Rule 4.17(ii)) for the following designations AE, AG, AL, AM, AT, AU, AZ, BA, BB, BG, BR, BW, BY, BZ, CA, CH, CN, CO, CR, CU, CZ, DE, DK, DM, DZ, EC, EE, EG, ES, FI, GB, GD, GE, GH, GM, HR, HU, ID, IL, IN, IS, JP, KE, KG, KP, KR, KZ, LC, LK, LR, LS, LT, LU, LV, MA, MD, MG, MK, MN, MW, MX, MZ, NA, NI, NO, NZ, OM, PG, PH, PL, PT, RO, RU, SC, SD, SE, SG, SK, SL, SM, SY, TJ, TM, TN, TR, TT, TZ, UA, UG, UZ, VC, VN, YU, ZA, ZM, ZW, ARIPO patent (BW, GH, GM, KE, LS, MW, MZ, NA, SD, SL, SZ, TZ, UG, ZM, ZW), Eurasian patent (AM, AZ, BY, KG, KZ, MD, RU, TJ, TM), European patent (AT, BE, BG, CH, CY, CZ, DE, DK, EE, ES, FI, FR, GB, GR, HU, IE, IS, IT, LT, LU, MC, NL, PL, PT, RO, SE, SI, SK, TR), OAPI patent (BF, BJ, CF, CG, CI, CM, GA, GN, GQ, GW, ML, MR, NE, SN, TD, TG)*
- *as to the applicant's entitlement to claim the priority of the earlier application (Rule 4.17(iii)) for the following designations AE, AG, AL, AM, AT, AU, AZ, BA, BB, BG, BR, BW, BY, BZ, CA, CH, CN, CO, CR, CU, CZ, DE, DK, DM, DZ,*

EC, EE, EG, ES, FI, GB, GD, GE, GH, GM, HR, HU, ID, IL, IN, IS, JP, KE, KG, KP, KR, KZ, LC, LK, LR, LS, LT, LU, LV, MA, MD, MG, MK, MN, MW, MX, MZ, NA, NI, NO, NZ, OM, PG, PH, PL, PT, RO, RU, SC, SD, SE, SG, SK, SL, SM, SY, TJ, TM, TN, TR, TT, TZ, UA, UG, UZ, VC, VN, YU, ZA, ZM, ZW, ARIPO patent (BW, GH, GM, KE, LS, MW, MZ, NA, SD, SL, SZ, TZ, UG, ZM, ZW), Eurasian patent (AM, AZ, BY, KG, KZ, MD, RU, TJ, TM), European patent (AT, BE, BG, CH, CY, CZ, DE, DK, EE, ES, FI, FR, GB, GR, HU, IE, IS, IT, LT, LU, MC, NL, PL, PT, RO, SE, SI, SK, TR), OAPI patent (BF, BJ, CF, CG, CI, CM, GA, GN, GQ, GW, ML, MR, NE, SN, TD, TG)

- *of inventorship (Rule 4.17(iv)) for US only*

Published:

- *without international search report and to be republished upon receipt of that report*

For two-letter codes and other abbreviations, refer to the "Guidance Notes on Codes and Abbreviations" appearing at the beginning of each regular issue of the PCT Gazette.

CONTENT STORAGE METHOD AND SYSTEM

BACKGROUND OF THE INVENTION

1. Field of the Invention

5 The invention relates to content distribution techniques and to personal video recorders (PVRs).

2. Background Art

10 The video cassette recorder (VCR) has been used for many years to allow users to record video programming to tape for personal use. Most modern video cassette recorders (VCRs) include a programmable memory to allow users to program the VCR in advance to later record a particular program. In this way, at the programmed time, the VCR tunes to the programmed channel and records the present video programming to tape. Over time, the VCR programmable memory
15 feature has been enhanced to simplify programming.

 Today, many viewers have turned to the personal video recorder (PVR) to record video programming for personal use. The PVR usually includes a hard disk drive and records video programming as digital video files on the hard disk drive. The PVR is able to provide all of the functionality associated with the
20 traditional VCR, and provide some additional capabilities. One of these additional capabilities that has become quite popular is the ability to pause, rewind, and fast forward live broadcast programming.

 Existing PVRs have been quite successful, but some have perceived certain disadvantages associated with the PVR. U.S. Pub. No. 2003/0208767 A1
25 enumerates some perceived disadvantages of the PVR and describes network-based interactive programming and services. All content is recorded at the headend and a content license approach is utilized where a user may reserve programs.

SUMMARY OF THE INVENTION

It is an object of the invention to provide an improved content storage method that utilizes a file locker-based approach. A user has a personal file locker on the network. When content is stored in the user's file locker, it is available for the user to watch. This innovative file locker-based approach provides improvements over the existing PVR by, for example, providing added flexibility and economy of scale. At the same time, this innovative file locker-based approach may avoid some of the limitations associated with a content license approach. In this way, the personal file locker provides a solution that is not comprehended by the prior art.

In carrying out the invention, a content storage method is provided for use in a content distribution network. The content distribution network provides broadcast video programming over the network to a plurality of users in accordance with a broadcasting schedule. The method comprises establishing a personal file locker on the network for a user. The file locker includes network storage space allocated for personal use by the user. The method further comprises establishing a content-storage-request database. The database tracks requests by the user for placing broadcast video programs into the user's file locker for personal use by the user. Requested content is stored in the user's file locker upon broadcast thereof and is thereafter made available to the user. Upon a request to view by the user, content stored in the user's file locker may be viewed. In this way, the invention provides a content storage area or file locker that a user can manage as if it were in his/her home. Operations supported include adding content, accessing content, and removing content.

It is appreciated that the file locker-based approach provided by the invention provides flexibility and economy of scale by implementing a personal file locker for the user on the network. It is further appreciated that the file locker-based approach provided by the invention provides a personal storage-space allocation for personal use by the user and in this way may avoid some of the limitations associated with a content license approach. The invention provides an

improved content storage method that provides the flexibility and economy of scale of a network solution, and provides the personal use and management of an in-home solution, brought together in the file locker-based method.

At a more detailed level, the invention comprehends many possible features as further described below. The personal file locker may be established in any suitable way such as a directory or other file system/volume construct that is created to hold the user's content. A database entry in a file-locker database notes the details of the file locker. It is also to be appreciated that the content-storage-request database may be established in any suitable way. In a suitable approach, the content-storage-request database has entries corresponding to scheduled video programs, and a content-storage request by the user results in the addition of a pointer to the content-storage-request database entry for the requested program. The pointer points to the requesting user's file locker, or more specifically, points to the user's record in the file-locker database. When the pointer is added, the user's record in the file-locker database is also annotated so that the requests for that file locker can be tracked.

In the approach just described, a request by the user to delete a previous content-storage request is handled by removing the previously added pointer and removing the corresponding annotation.

Further, it is appreciated that the invention contemplates storing a requested video program to the user's file locker upon broadcast of the video program. It is further appreciated that the invention comprehends the storing of a requested video program to the user's file locker upon the general making of the video program available to the end user in any suitable fashion.

With regard to storing the video program in the user's file locker, it is appreciated that any suitable data storage technique may be utilized to effectively get the data available at the appropriate file lockers. With regard to the later viewing of the stored video program, content viewing requests are authenticated to identify which subscriber is making the request so that access to a subscriber's file

locker is limited to that subscriber. Preferably, the user may utilize pause, rewind, and fast forward features while viewing.

Further, in carrying out the invention, a content storage system for use in a content distribution network is provided. The content distribution network provides broadcast video programming over the network to a plurality of users in accordance with a broadcasting schedule. The system comprises a personal file locker on the network for a user. The file locker is a construct created to hold the user's content and includes network storage space allocated for personal use by the user. The system further comprises a content-storage-request database for tracking requests by the user for placing broadcast video programs into the user's file locker for personal use by the user. The system further comprises computer instructions executable by a computer on the network. Upon the broadcasting of a video program for which there exists a request by the user to place the video program into the user's file locker, the computer instructions direct the storage of the video program in the user's file locker, and make the stored video program available to the user for viewing.

The system may incorporate any of the various aspects of the content storage methods provided. As appropriate, computer instructions executable by a computer on the network are utilized to carry out various aspects of the invention. It is appreciated that the implementation of computer instructions executable by a computer may be achieved in any suitable way. In addition, it is appreciated that the content storage systems and methods may be used in other arrangements where broadcast programming is provided over a network and are not strictly limited to broadcast video programming arrangements.

Further, in carrying out the invention, a content storage method is provided in which a plurality of personal file lockers are established on the network for a plurality of users. Each file locker includes network storage space allocated for personal use by the corresponding user. The method further comprises establishing a content-storage-request database for tracking requests by the plurality of users for placing broadcast video programs into their file lockers for personal

use. The method further comprises, upon the broadcasting of a video program for which there exists at least one request by a user to place the program into the user's file locker, storing that video program in each requesting user's file locker. The stored video program is made available for viewing by each user whose file locker
5 received the video program.

In another aspect of the invention, a content storage system comprising a plurality of personal file lockers on the network for a plurality of users is provided. In the system, computer instructions executable by a computer on the network are utilized to store video programs in appropriate file lockers and make the
10 stored video programs available for viewing by users.

In addition to the various approaches described above for carrying out the invention in ways that involve providing content storage methods and systems that use a file locker-based approach, instantiation of the invention may take place in alternative ways and involve independent alternative approaches to carrying out
15 the invention to achieve independent alternative embodiments of the invention. Thus, the invention as a whole comprehends various different alternative and independent approaches for carrying out the various concepts involved.

In carrying out the invention in a first alternative approach, a method for time-shifted viewing of content for use in a content distribution network is
20 provided. The content distribution network delivers a plurality of broadcast video programs over the network to a plurality of viewers in accordance with a broadcast schedule. The method comprises allocating a remote personal storage resource on the network for a user. The method further comprises receiving a request by the user for storage of a desired one or more of the broadcast video programs. The
25 method further comprises, only if the request is received no later than a scheduled broadcast of the desired program, in response to the request automatically storing the desired video program in the user's remote personal storage resource upon the scheduled broadcasting of the desired video program. The method further comprises automatically making the stored video program available to the user over
30 the network for viewing at a subsequent time specified by the user.

At a more detailed level, the method in the first alternative approach comprehends further features. For example, a quantity limit on how much total content can be stored for the user in the remote personal storage resource may be established. For example, one or more limits for each of the stored video programs, including one or more limits selected from: {an expiration date, a maximum permitted number of repeated viewings} may be established. For example, the user may be charged a fee in exchange for raising one or more of the limits. Further, the desired broadcast video program may be a television series, and the user request may be a single interactive request for storage of a plurality of installments of the series. The content distribution network may include broadband network infrastructure selected from one or more of the following: {cable television network, satellite network, telephone network, wireless network, power line network}. The content distribution network may include packet-switched network infrastructure.

In carrying out the invention in a second alternative approach, a method for providing personal video recorder ("PVR") functionality to a user via a content distribution network is provided. The method comprises receiving a request by the user for storage of desired video content no later than a scheduled telecast to a plurality of viewers of the desired content. The method further comprises, in response to the request only upon the scheduled telecast of the desired content, and only if the user is one of the viewers who is entitled to receive the desired program at the time of the scheduled telecast, storing the desired content in a remote network-based storage facility for the user. The method further comprises making the stored content available to the user over the network with viewing functionality including at least one or more PVR features selected from: {time-shifted viewing, pause, rewind, fast-forward}.

At a more detailed level, the method in the second alternative approach comprehends further features. For example, the request may be received from the user during the scheduled telecast, the user request may be for storage of a not-yet-telecast portion of the desired video content, storing the desired content may comprise storing the portion. For example, the user request may be for rolling storage of currently viewed video content and storing the requested video content

may comprise storing most recently viewed video content in a buffer of predetermined length in the remote storage facility. For example, the method may further include non-real-time display for the user of at least some of the desired content during the scheduled telecast of the content, in response to an interactive
5 request of the user. The non-real-time display may include at least one or more viewing modes selected from {pause, rewind, fast forward}.

In carrying out the invention in a third alternative approach, a network-based personal video recording system is provided. The system comprises
10 a network-based storage resource configured to store desired video programming in response to a remote user's electronic request. The system further comprises a content distribution network configured to deliver the stored desired programming to the user. The system automatically performs the storing and delivering of the desired programming under the interactive control of the requesting user, without
15 a need for legal permission from a copyright owner of the desired programming to perform the storing and distributing.

At a more detailed level, the method in the third alternative approach comprehends further features. For example, the automatic storing and delivering of the desired video programming under interactive control of the user may be
20 performed in a manner intended to qualify as a fair use under copyright law.

It is appreciated that in this approach, storing and delivering without a need for legal permission from a copyright owner of the desired programming to perform the storing and distribution means that these actions use the desired programming in a way that those of ordinary skill in the art of copyrights as applied
25 in personal video recording systems would appreciate and understand does not require legal permission. It is further appreciated by those skilled in the relevant arts that the actions use the desired programming in a way that does not require legal permission from a copyright owner of the desired programming and that these actions occur in a particular combination of other structures and functions which
30 include the network-based storage resource and the content distribution network. This approach to carrying out the invention also comprehends performing storing

and delivering actions that use the desired programming in a way that those skilled in the relevant arts would appreciate and understand does not give rise to legal liability.

Accordingly, it is to be understood that this approach to carrying out the invention is not to be limited to any specific instance of the factors involved in determining the absence of a need for legal permission, or the absence of legal liability. Rather, this approach to carrying out the invention transcends such specific instances of these factors and should be considered as comprehending the combination of a network-based personal video recording system including a network-based storage resource, and a content distribution network wherein the system performs the actions of storing and delivering in a way that does not require legal permission from a copyright owner in the particular situation at hand as would be readily understood by those skilled in the relevant arts.

Also comprehended is a combination of a network-based personal video recording system including a network-based storage resource, and a content distribution network wherein the system performs the actions of storing and delivering in a way that does not give rise to legal liability in the particular situation at hand as would be readily understood by those skilled in the relevant arts.

One instance of the factors involved in determining the absence of a need for legal permission is the present existing fair use privilege of individuals to take certain actions with content without the need for legal permission. One instance of the factors involved in determining the absence of legal liability occurs in the provisions of the Digital Millennium Copyright Act (DMCA) which shields online service providers from direct, vicarious and contributory liability for content stored at the direction of users.

BRIEF DESCRIPTION OF THE DRAWINGS

FIGURE 1 is a content distribution network and content storage system in an embodiment of the invention;

FIGURE 2 illustrates the content-storage-request database, file-locker
5 database, and file locker cooperation in more detail;

FIGURE 3 illustrates a content storage method in an embodiment of the invention;

FIGURE 4 illustrates authentication and viewing of a video program in more detail;

FIGURE 5 illustrates a first alternative approach to carrying out the
10 invention;

FIGURE 6 illustrates a second alternative approach to carrying out the invention; and

FIGURE 7 illustrates a third alternative approach to carrying out the
15 invention.

DETAILED DESCRIPTION OF THE PREFERRED EMBODIMENT

With reference to Figures 1 and 2, a content distribution network and content storage system in an embodiment of the invention are illustrated. Signals are distributed by headend 10. Headend 10 receives content from source 12. The
20 distribution network 14 is shown in a simplified fashion with the final signal distribution reaching subscribers 16. A user or subscriber 16 has a personal file locker 18 on the network 14. This file locker-based content storage system implementation further includes file-locker database 20 and content-storage-request database 22. Headend 10 provides broadcast video programming over network 14

to users 16 in accordance with a broadcasting schedule. A personal file locker 18 is established for each user 16 and includes network storage space allocated for personal use by the user. Content-storage-request database 22 tracks requests by the users for placing broadcast video programs into the users' file lockers 18. More specifically, a specific user's requested content is stored in that user's file locker upon broadcast thereof and is thereafter made available to that user.

The personal file locker may be established in any suitable fashion such as a directory or other file system/volume construct that is created to hold the user's content. A database entry in the file-locker database 20 notes details of the file locker. This is best illustrated in Figure 2 where each block 30 represents a file-locker description entry within file-locker database 20. As shown, each file-locker description 30 corresponds to a particular personal file locker 18, which in turn corresponds to a particular user or subscriber 16.

Content-storage-request database 22 may be established in any suitable way. As best shown in Figure 2, in the illustrated embodiment, content-storage-request database 22 has entries 32 corresponding to scheduled video programs. A content-storage request by a user results in the addition of a pointer 34 to the content-storage-request database entry for the requested program.

As shown in Figure 2, when a subscriber 16 requests a particular video program for placement in the subscriber's personal file locker 18, a pointer 34 is added in the entry 32 for the particular video program within the content-storage-request database 22. The added pointer points to the file-locker description 30 for the personal file locker 18 for the subscriber 16 making the request. Further, the subscriber's entry in the file-locker database 20 is annotated so that the requests for any particular file locker may be tracked within the corresponding file-locker description in file-locker database 20. In the approach just described, a request by the user to delete a previous content-storage request is handled by removing the previously added pointer and removing the corresponding annotation to the file-locker description.

As mentioned, the video program 32 is stored to the user's file locker 18 upon the general making of the video program available to the end user in any fashion, for example, when the video program is broadcasted. The file locker-based approach provided by the illustrated embodiment provides flexibility and economy of scale by implementing a personal file locker for the user on the network. Personal file lockers 18 on network 14 provide the flexibility and economy of scale of a network solution, while at the same time, providing the personal feel of an in-home solution and avoiding some limitations typically associated with a content license management approach.

With regard to the storing of the programs in the file lockers, any suitable data storage technique may be utilized to effectively get the data available at the appropriate file lockers. Once data is stored in a file locker, access requests to view the contents are authenticated to assure that contents of a file locker are handled as personal-use copies for the associated subscriber. During playback of content from the file locker, the subscriber may utilize pause, rewind, and fast forward features while viewing.

In the implementation of the illustrated embodiment, the customer subscribes to the file-locker service and specifies or selects an amount of storage (expressed in Gigabytes, hours of video content, and/or number of shows) for his/her personal file locker 18. With a file locker established, the subscriber is able to request that content be placed in his/her personal file locker 18. Only content that is available to the subscriber on his/her television (or other devices receiving broadcast content such as computers) can be placed in his/her file locker 18. Access to the file locker 18 is restricted to the subscriber, and optionally, further restricted to the subscriber's premises (but could allow viewing from any of the televisions, computers, or other video display devices). Various techniques are contemplated for the subscriber to control content within the file locker. That is, the subscriber can direct content additions to his/her file locker using a web interface, and/or a television-based interface. Content that the user has requested is stored in his/her personal file locker. This content counts against the amount of storage associated with the subscription to the service.

When content is stored in a service user's file locker, it becomes available for the user to watch. The user can also direct content deletions from the file locker to free up space. In another aspect, the user may be able to set up expiration dates for content, essentially requesting that the system remove content
5 after a certain period of time to preserve free space inside the file locker. The user may be able to specify rules for the automated management of the file locker in another aspect of the invention, for example, what should happen when the file locker does not have enough space to store a program that the user has requested.

When the user selects a piece of content from the file locker for
10 viewing, the user is able to watch it very much the way that he/she would be able to watch VCR or PVR recorded content. For example, fast forward, rewind, pause, and other viewing commands may be available to the user.

With reference to Figures 3 and 4, further details of the technical aspects of the illustrated embodiment are explained below. In Figure 3, the content
15 storage method in an embodiment of the invention is illustrated. At block 40, the file-locker database is established. At block 42, the content-storage-request database is established. At block 44, a personal file locker is established on the network for a user. More specifically, when a user signs up for the file-locker service, the system sets up a file locker and reserves storage space for it. The content-storage-
20 request database tracks which users have requested which programs be placed in their respective file lockers. A web or television interface that allows users to request content only allows a user to request content that the user is entitled to access as part of his/her normal video subscription.

According to the database of user content requests, the system stores
25 the requested content when it is broadcast. For example, if the user requests that the 6:00 p.m. news on channel 7 be saved in the user's file locker, the 6:00 p.m. news is stored in the locker, ideally in real time starting at 6:00 p.m. The content becomes available to the user as soon as it is stored in the user's file locker.

If a number of users request the same content, the system may store a separate copy in each requesting user's file locker. If a user unsubscribes from the file-locker service, the user's file locker is deallocated and any content in it is deleted. In addition, the database entry in the file-locker database is deleted or
5 marked inactive.

When a content storage request is received from the user, first a check is made to see if the user's file locker has enough space to store the selected content. The check considers the current amount of space available, any pending content storage requests, and any storage management policies in place for that file
10 locker. If sufficient space is available, a pointer is added for the given program that points to the file-locker database entry for the file locker of the subscriber making the request. The subscriber's record in the file-locker database is also annotated.

In Figure 3, blocks 46 and 48 illustrate adding pointers to the content-storage-request database entries in response to user requests and annotating file-locker database entries to note the pointers. This concept is also illustrated in
15 Figure 2 where content-storage-request database 22 includes video programs 32 where pointers 34 point to file-locker descriptions 30 corresponding to personal file lockers 18 that correspond to subscribers 16.

At block 50 user requests/pointers are tracked and video programs are stored to file lockers. More specifically, the content-storage-request database is monitored. Each time a program begins (based on EPG data or other sources including human input), each file locker that is listed as having requested that content is given a copy of the program. The program may be stored in the file
20 lockers in real-time by streaming into a file in each locker, or the program may be copied in large blocks to each locker at the end of the program's broadcast. In no case is content available to the user from the file locker prior to broadcast or the otherwise general availability of the content. In the case where the content is available only in analog format, it is first digitally encoded and then stored in the file
25 locker.
30

In the case where the content is digitally encrypted, it is stored in encrypted form in the file locker. This encryption may be the default encryption or the content may be encrypted using an encryption system more appropriate for stored content.

5 At block 52, stored video programs in a user's file locker are made available to the user for viewing. More specifically, when a request is made to view a piece of content in a file locker, the request is first authenticated to identify which subscriber is making the request. This is illustrated in more detail in Figure 4 where block 54 illustrates authentication and block 56 illustrates providing the video program for viewing. Only content that is in a particular subscriber's file locker is available to that subscriber for viewing. Assuming that the content requested is in the authenticated user's file locker, the content is transmitted to the user. The user is able to use VCR or PVR commands including pause, fast forward, and rewind while viewing the content. When reaching the end of the content or pressing stop, 10 the user may be asked whether he/she would like to remove the content from his/her file locker. 15

In the preferred implementation, when a file is stored in a user's file locker, if there is not enough space for the file, the system may remove files using criteria set up by the user in order to make enough space for the new file. Such 20 criteria may include the age of the other files, whether the files have been accessed recently, and the size of the files.

There are also several optional improvements that may further be incorporated into embodiments of the invention. These optional improvements relate to the way that programs are stored in a user's file locker.

25 One optional improvement to the implementation is to implement a file system that recognizes multiple files with the same content being stored and efficiently stores them to reduce the redundant use of storage space. With the exception of performance, this file system behaves exactly as a traditional file system would behave. The differences are indistinguishable to the user except that

it delivers a greater level of performance at a lower cost. Ideally this file system would identify duplicate file storage requests through specified similarities in meta data associated with the file, for example, file name. An alternative is to enable bulk versions of traditional file system operations (such as file open, file write, etc.) that operate on multiple files simultaneously. In this way, the system could easily identify which files contained identical data and optimization of applications using the file system would be enhanced by reducing the number of file operations/procedure calls that are required. In any case, files, whether manipulated in bulk or individually, would always behave as if they were independent files.

Another optional improvement to the implementation is to allow the system to automatically expand a user's file locker to accommodate content that the user has requested. The user may be charged additional fees based on the total amount of storage used. This would change the implementation above in that instead of ensuring that a user does not exceed a given amount of space, a log or other mechanism would be kept so that the maximum amount of storage used by a user during a time period (e.g., a month) could be ascertained for billing purposes.

It is appreciated that embodiments of the invention provide an improved content storage system and method. As exemplified by the illustrated embodiment, the personal file locker on the network provides improvements over existing PVR by providing added flexibility and economy of scale while taking a personal-use approach that may avoid some difficulties encountered in a rights-management license approach.

In addition to the file locker approach embodiment illustrated in Figures 1-4, there are additional alternative approaches illustrated in Figures 5-7.

In Figure 5, a method for time-shifted viewing of content for use in a content distribution network is illustrated. The content distribution network delivers a plurality of broadcast video programs over the network to a plurality of viewers in accordance with a broadcast schedule. At block 60, a remote personal storage resource is allocated on the network for a user. At block 62, a request by

the user for storage of a desired one or more of the broadcast video programs is received. At block 64, only if the request is received no later than a scheduled broadcast of the desired program, in response to the request, the desired video program is automatically stored in the user's remote personal storage resource upon
5 the scheduled broadcasting of the desired video program. At block 66, the stored video program is automatically made available to the user over the network for viewing at a subsequent time specified by the user.

In Figure 6, a method for providing personal video recorder (PVR) functionality to a user via a content distribution network is illustrated. At block 70,
10 a request by the user for storage of desired video content is received. The request is received no later than a scheduled telecast to a plurality of viewers of the desired content. At block 72, in response to the request, only upon the scheduled telecast of the desired content, and only if the user is one of the viewers who is entitled to receive the desired program at the time of the scheduled telecast, the desired content
15 is stored in a remote network-based storage facility for the user. At block 74, the stored content is made available to the user over the network with viewing functionality including at least one or more PVR features selected from: {time-shifted viewing, pause, rewind, fast-forward}.

In Figure 7, a network-based personal video recording system carries
20 out the illustrated actions in blocks 80 and 82. At block 80, desired video programming is stored in response to a remote user's electronic request. A content distribution network is configured to deliver the stored desired video programming to the user. At block 82, the system automatically performs the storing and delivering of the desired programming under the interactive control of the user,
25 without a need for legal permission from a copyright owner of the desired programming to perform the storing and distributing.

It is appreciated that the additional alternative approaches illustrated in Figures 5-7 may involve additional features at the more detailed level. Further, it is appreciated that various approaches to carrying out the invention to achieve
30 various independent alternative embodiments of the invention are described above.

The invention as a whole comprehends various different alternative and independent approaches for carrying out the various concepts involved, and the invention may be instantiated in various ways to achieve various embodiments, including the particular embodiments described above and illustrated in the drawings, as well as
5 other embodiments of any of the innovative concepts presented.

While embodiments of the invention have been illustrated and described, it is not intended that these embodiments illustrate and describe all possible forms of the invention. Rather, the words used in the specification are words of description rather than limitation, and it is understood that various changes
10 may be made without departing from the spirit and scope of the invention.

WHAT IS CLAIMED IS:

1. A content storage method for use in a content distribution network, the content distribution network providing broadcast video programming over the network to a plurality of users in accordance with a broadcasting schedule,
5 the method comprising:

establishing a personal file locker on the network for a user, the file locker including network storage space allocated for personal use by the user;

establishing a content-storage-request database for tracking requests by the user for placing broadcast video programs into the user's file locker for
10 personal use by the user;

upon the broadcasting of a video program for which there exists a request by the user to place the video program into the user's file locker, storing that video program in the user's file locker; and

making the stored video program available to the user for viewing.

2. The method of claim 1 wherein the personal file locker is a
15 construct created to hold the user's content, and wherein the method further comprises:

establishing a file-locker database for storing a description of the file locker construct.

3. The method of claim 1 wherein the content-storage-request
20 database has entries corresponding to scheduled video programs, and wherein the method further comprises:

upon the occurrence of a content request by the user for a program, adding a pointer to the content-storage-request database entry for the requested
25 program, the pointer designating the requesting user's file locker; and

upon the broadcasting of the requested program, storing the requested program in the user's file locker.

4. The method of claim 3 wherein the personal file locker is a construct created to hold the user's content, and wherein the method further comprises:

5 establishing a file-locker database for storing a description of the file locker construct, wherein the added pointer points to the entry in the file-locker database for the requesting user's file locker.

5. The method of claim 4 further comprising:
annotating the entry in the file-locker database for the requesting user's file locker to note the presence of the pointer.

10 6. The method of claim 5 further comprising:
upon the occurrence of a request by the user to delete the previous content request by the user, removing the previously added pointer and removing the annotation.

15 7. The method of claim 1 wherein the content distribution network generally makes video programming available over the network to the plurality of users, and wherein the method further comprises:

tracking requests by the user for placing available video programs into the user's file locker for personal use by the user; and

20 upon the general making available of a video program for which there exists a request by the user to place the video program into the user's file locker, storing that video program in the user's file locker.

8. The method of claim 1 further comprising:
authenticating a request by the user to view the available stored video program to authenticate the requesting user.

25 9. The method of claim 1 further comprising:
providing the available stored video program to the user for viewing;
and
during viewing, providing pause, rewind, and fast forward features.

10. A content storage system for use in a content distribution network, the content distribution network providing broadcast video programming over the network to a plurality of users in accordance with a broadcasting schedule, the system comprising:

5 a personal file locker on the network for a user, the file locker being a construct created to hold the user's content and including network storage space allocated for personal use by the user;

10 a content-storage-request database for tracking requests by the user for placing broadcast video programs into the user's file locker for personal use by the user; and

15 computer instructions executable by a computer on the network to, upon the broadcasting of a video program for which there exists a request by the user to place the video program into the user's file locker, store that video program in the user's file locker, and make the stored video program available to the user for viewing.

11. The system of claim 10 further comprising:

a file-locker database for storing a description of the file locker construct.

12. The system of claim 10 wherein the content-storage-request database has entries corresponding to scheduled video programs, and wherein the system further comprises:

20 computer instructions executable by a computer on the network to, upon the occurrence of a content request by the user for a program, add a pointer to the content-storage-request database entry for the requested program, the pointer designating the requesting user's file locker; and

25 computer instructions executable by a computer on the network to, upon the broadcasting of the requested program, store the requested program in the user's file locker.

13. The system of claim 12 further comprising:

a file-locker database for storing a description of the file locker construct, wherein the added pointer points to the entry in the file-locker database for the requesting user's file locker.

5

14. The system of claim 13 further comprising:

computer instructions executable by a computer on the network to annotate the entry in the file-locker database for the requesting user's file locker to note the presence of the pointer.

10

15. The system of claim 14 further comprising:

computer instructions executable by a computer on the network to, upon the occurrence of a request by the user to delete the previous content request by the user, remove the previously added pointer and remove the annotation.

15

16. The system of claim 10 wherein the content distribution network generally makes video programming available over the network to the plurality of users, and wherein the system further comprises:

computer instructions executable by a computer on the network to track requests by the user for placing available video programs into the user's file locker for personal use by the user; and

20

computer instructions executable by a computer on the network to, upon the general making available of a video program for which there exists a request by the user to place the video program into the user's file locker, store that video program in the user's file locker.

25

17. The system of claim 10 further comprising:

computer instructions executable by a computer on the network to authenticate a request by the user to view the available stored video program to authenticate the requesting user.

18. The system of claim 10 further comprising:
computer instructions executable by a computer on the network to
provide the available stored video program to the user for viewing; and
computer instructions executable by a computer on the network to,
5 during viewing, providing pause, rewind, and fast forward features.

19. A content storage method for use in a content distribution
network, the content distribution network providing broadcast video programming
over the network to a plurality of users in accordance with a broadcasting schedule,
the method comprising:
10 establishing a plurality of personal file lockers on the network for a
plurality of users, each file locker including network storage space allocated for
personal use by the corresponding user;
establishing a content-storage-request database for tracking requests
by the plurality of users for placing broadcast video programs into their file lockers
15 for personal use;
upon the broadcasting of a video program for which there exists at
least one request by a user to place the video program into the user's file locker,
storing that video program in each requesting user's file locker; and
making the stored video program available for viewing by each user
20 whose file locker received the video program.

20. A content storage system for use in a content distribution
network, the content distribution network providing broadcast video programming
over the network to a plurality of users in accordance with a broadcasting schedule,
the system comprising:
25 a plurality of personal file lockers on the network for a plurality of
users, each file locker including network storage space allocated for personal use by
the corresponding user;
a content-storage-request database for tracking requests by the
plurality of users for placing broadcast video programs into their file lockers for
30 personal use;

computer instructions executable by a computer on the network to, upon the broadcasting of a video program for which there exists at least one request by a user to place the video program into the user's file locker, store that video program in each requesting user's file locker; and

5 computer instructions executable by a computer on the network to make the stored video program available for viewing by each user whose file locker received the video program.

21. A method for time-shifted viewing of content for use in a content distribution network, the content distribution network delivering a plurality of broadcast video programs over the network to a plurality of viewers in accordance with a broadcast schedule, the method comprising:

allocating a remote personal storage resource on the network for a user;

15 receiving a request by the user for storage of a desired one or more of the broadcast video programs;

only if said request is received no later than a scheduled broadcast of the desired program, in response to the request automatically storing the desired video program in the user's remote personal storage resource upon the scheduled broadcasting of the desired video program; and

20 automatically making the stored video program available to the user over the network for viewing at a subsequent time specified by the user.

22. The method of claim 21, further comprising:

establishing a quantity limit on how much total content can be stored for the user in the remote personal storage resource.

25 23. The method of claim 22, further comprising charging the user a fee in exchange for raising one or more of said limits.

24. The method of claim 21, further comprising:
establishing one or more limits for each of the stored video programs,
including one or more limits selected from: {an expiration date, a maximum
permitted number of repeated viewings}.
- 5 25. The method of claim 24, further comprising charging the user
a fee in exchange for raising one or more of said limits.
26. The method of claim 21, wherein the desired broadcast video
program is a television series, and the user request is a single interactive request for
storage of a plurality of installments of the series.
- 10 27. The method of claim 21, wherein the content distribution
network includes broadband network infrastructure selected from one or more of the
following: {cable television network, satellite network, telephone network, wireless
network, power line network}.
- 15 28. The method of claim 21, wherein the content distribution
network includes packet-switched network infrastructure.
29. A method for providing personal video recorder ("PVR")
functionality to a user via a content distribution network, comprising:
receiving a request by the user for storage of desired video content
no later than a scheduled telecast to a plurality of viewers of the desired content;
20 in response to the request and only upon the scheduled telecast of the
desired content, and only if the user is one of the viewers who is entitled to receive
the desired program at the time of the scheduled telecast, storing the desired content
in a remote network-based storage facility for the user;
making the stored content available to the user over the network with
25 viewing functionality including at least one or more PVR features selected from:
{time-shifted viewing, pause, rewind, fast-forward}.

30. The method of claim 29, wherein the request is received from the user during the scheduled telecast; the user request is for storage of a not-yet-telecast portion of the desired video content; and storing the desired content comprises storing said portion.

5 31. The method of claim 29, wherein the user request is for rolling storage of currently viewed video content; and storing the requested video content comprises storing most recently viewed video content in a buffer of predetermined length in the remote storage facility.

10 32. The method of claim 31, further includes non-real-time display for the user of at least some of the desired content during the scheduled telecast of said content, in response to an interactive request of the user.

33. The method of claim 32, wherein non-real-time display includes at least one or more viewing modes selected from: {pause, rewind, fast forward}.

15 34. A network-based personal video recording system, comprising:

a network-based storage resource, configured to store desired video programming in response to a remote user's electronic request;

a content distribution network configured to deliver the stored desired programming to the user;

20 wherein said system automatically performs said storing and delivering of the desired programming under the interactive control of the requesting user, without a need for legal permission from a copyright owner of the desired programming to perform said storing and distributing.

25 35. The method of claim 34, wherein the automatic storing and delivering of the desired video programming under interactive control of the user are performed in a manner intended to qualify as fair use under copyright law.

36. A content storage method for use in a content distribution network, the content distribution network providing broadcast programming over the network to a plurality of users in accordance with a broadcasting schedule, the method comprising:

- 5 establishing a personal file locker on the network for a user, the file locker including network storage space allocated for personal use by the user;
- establishing a content-storage-request database for tracking requests by the user for placing broadcast programs into the user's file locker for personal use by the user;
- 10 upon the broadcasting of a program for which there exists a request by the user to place the program into the user's file locker, storing that program in the user's file locker; and
- making the stored program available to the user for viewing.

37. A content storage system for use in a content distribution network, the content distribution network providing broadcast programming over the network to a plurality of users in accordance with a broadcasting schedule, the system comprising:

- 15 a personal file locker on the network for a user, the file locker being a construct created to hold the user's content and including network storage space
- 20 allocated for personal use by the user;
- a content-storage-request database for tracking requests by the user for placing broadcast programs into the user's file locker for personal use by the user; and
- computer instructions executable by a computer on the network to,
- 25 upon the broadcasting of a program for which there exists a request by the user to place the program into the user's file locker, store that program in the user's file locker, and make the stored program available to the user for viewing.

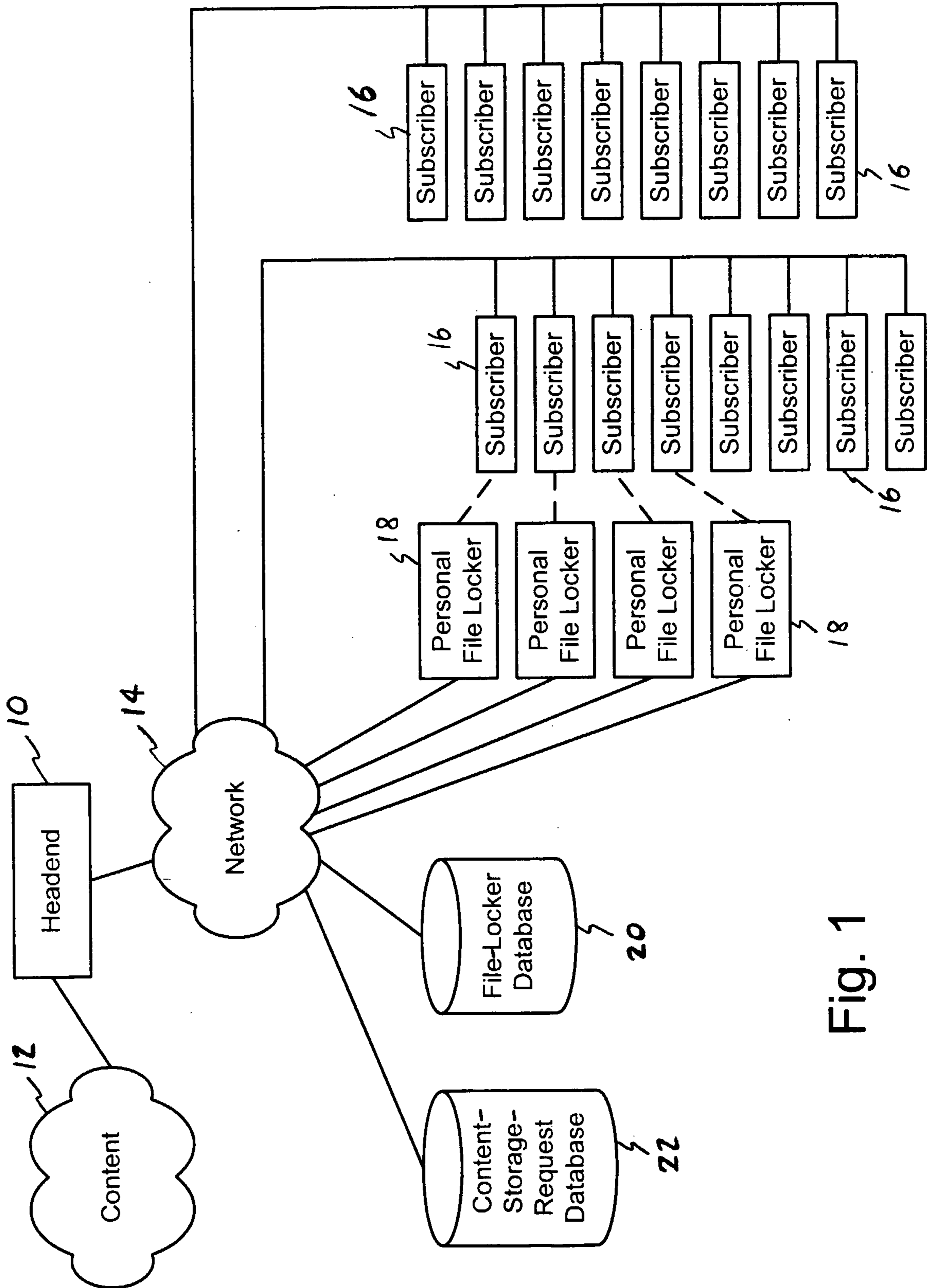

Fig. 1

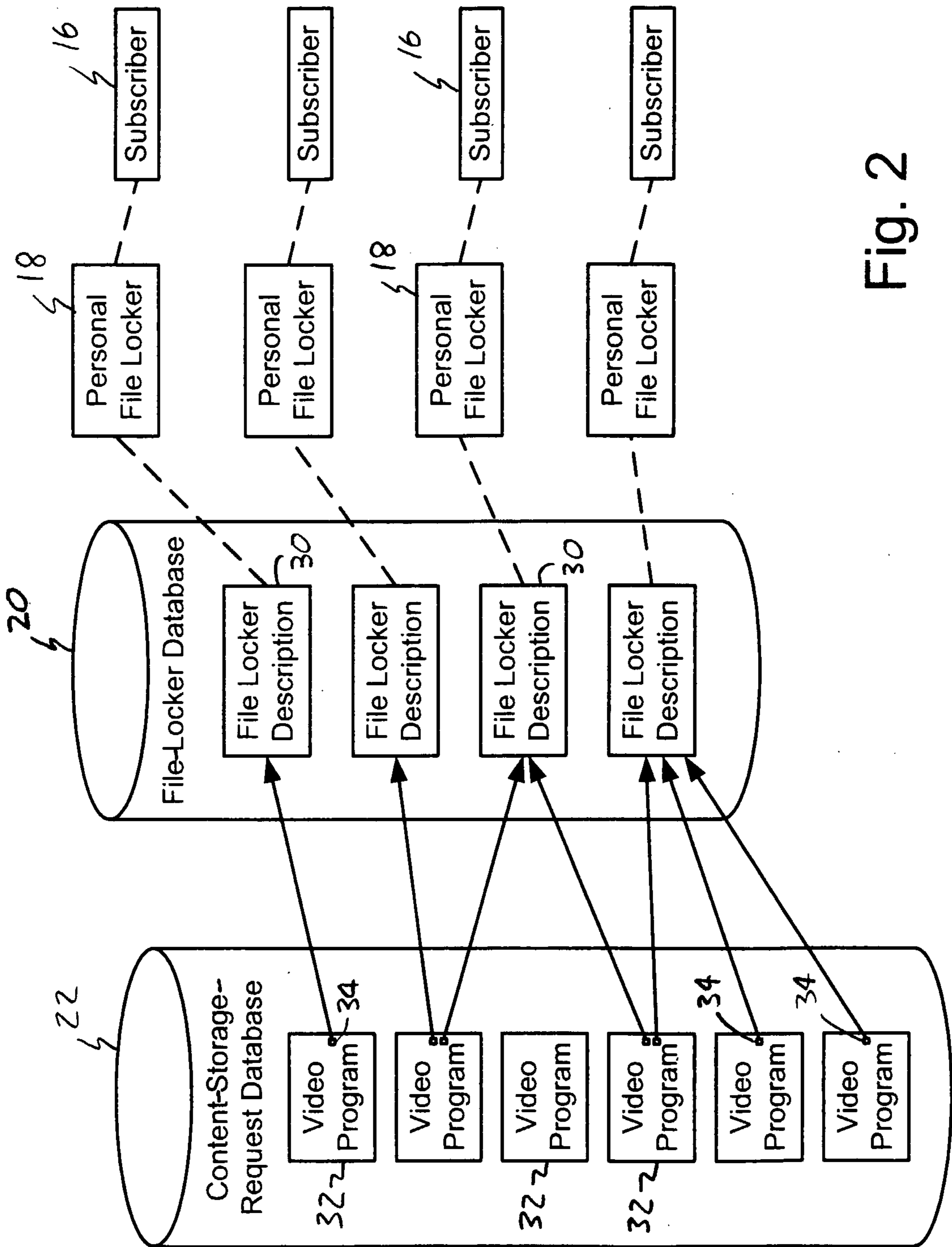

Fig. 2

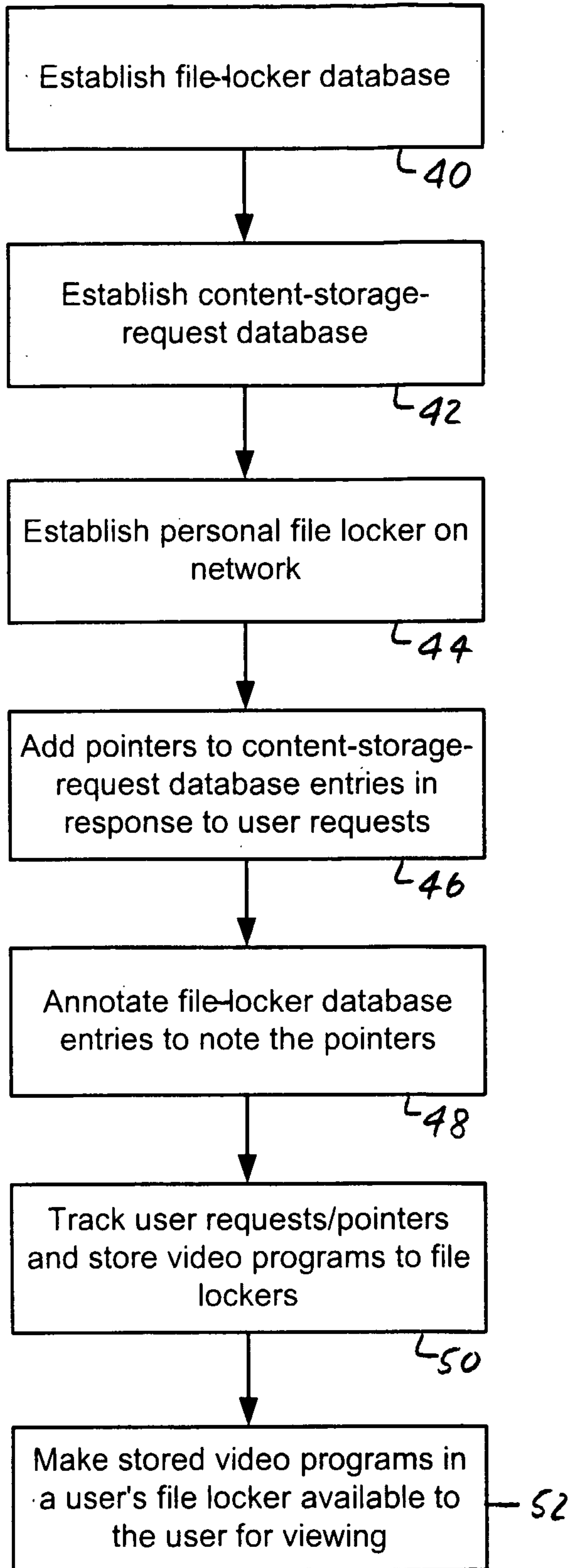

Fig. 3

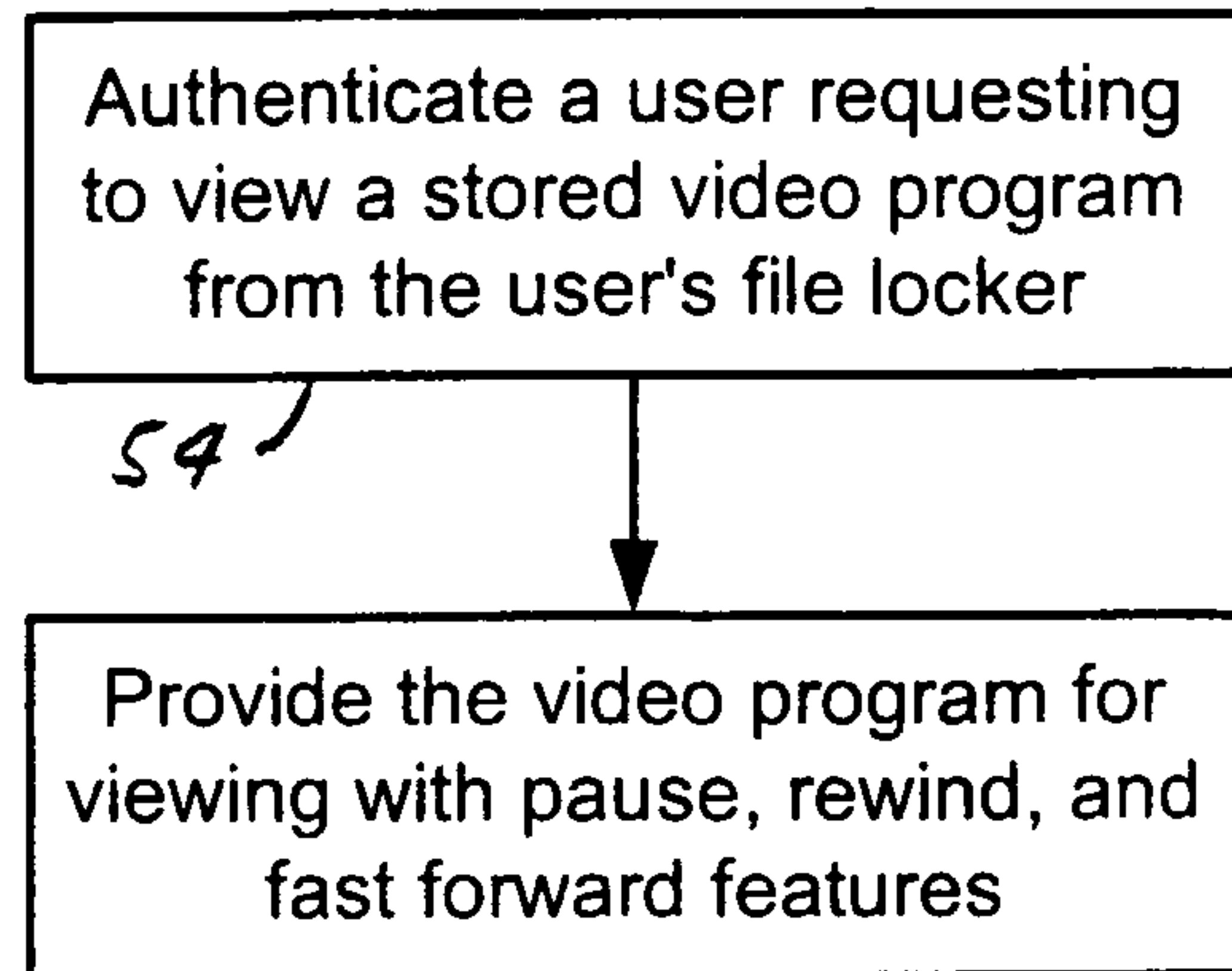
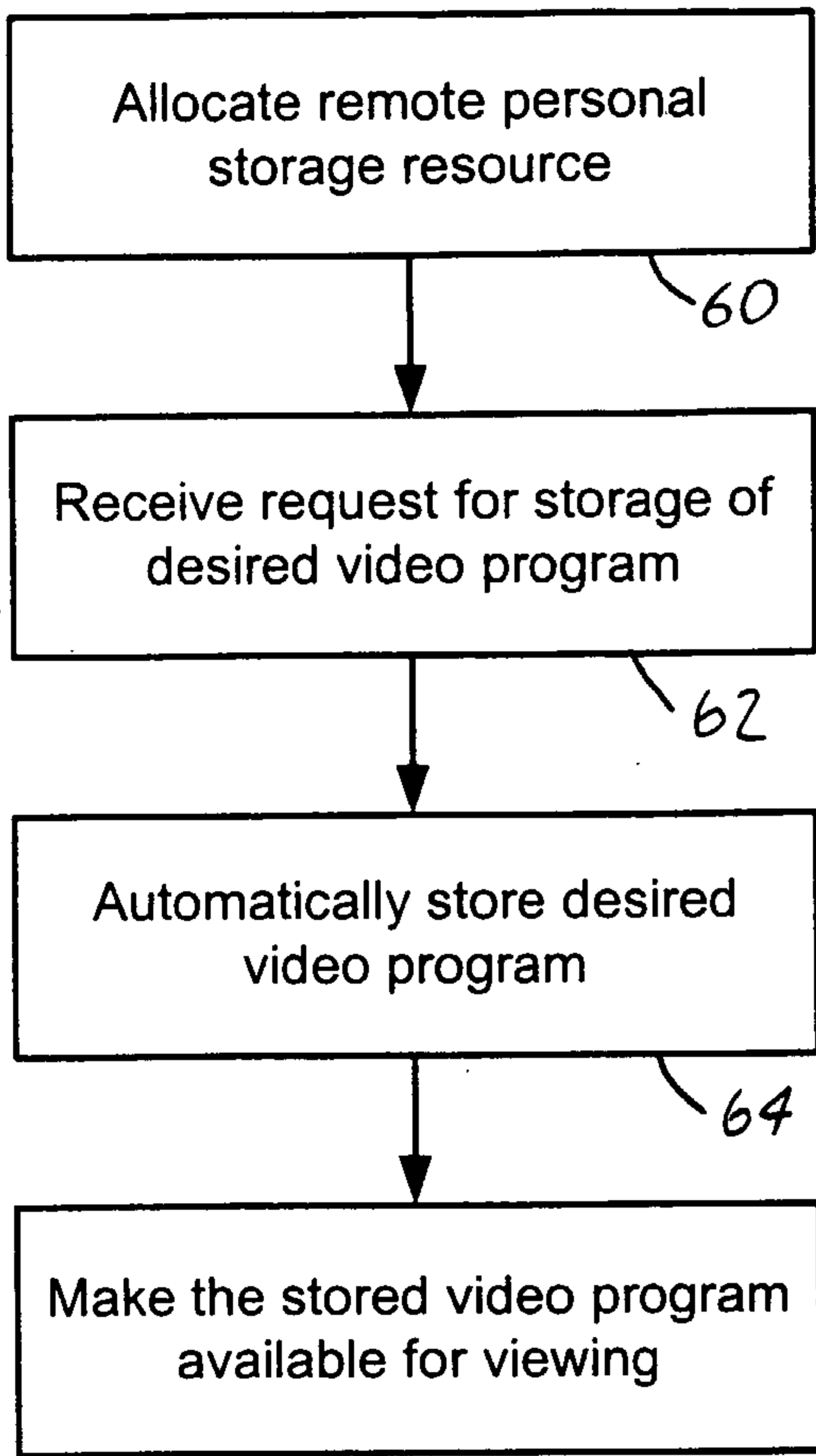
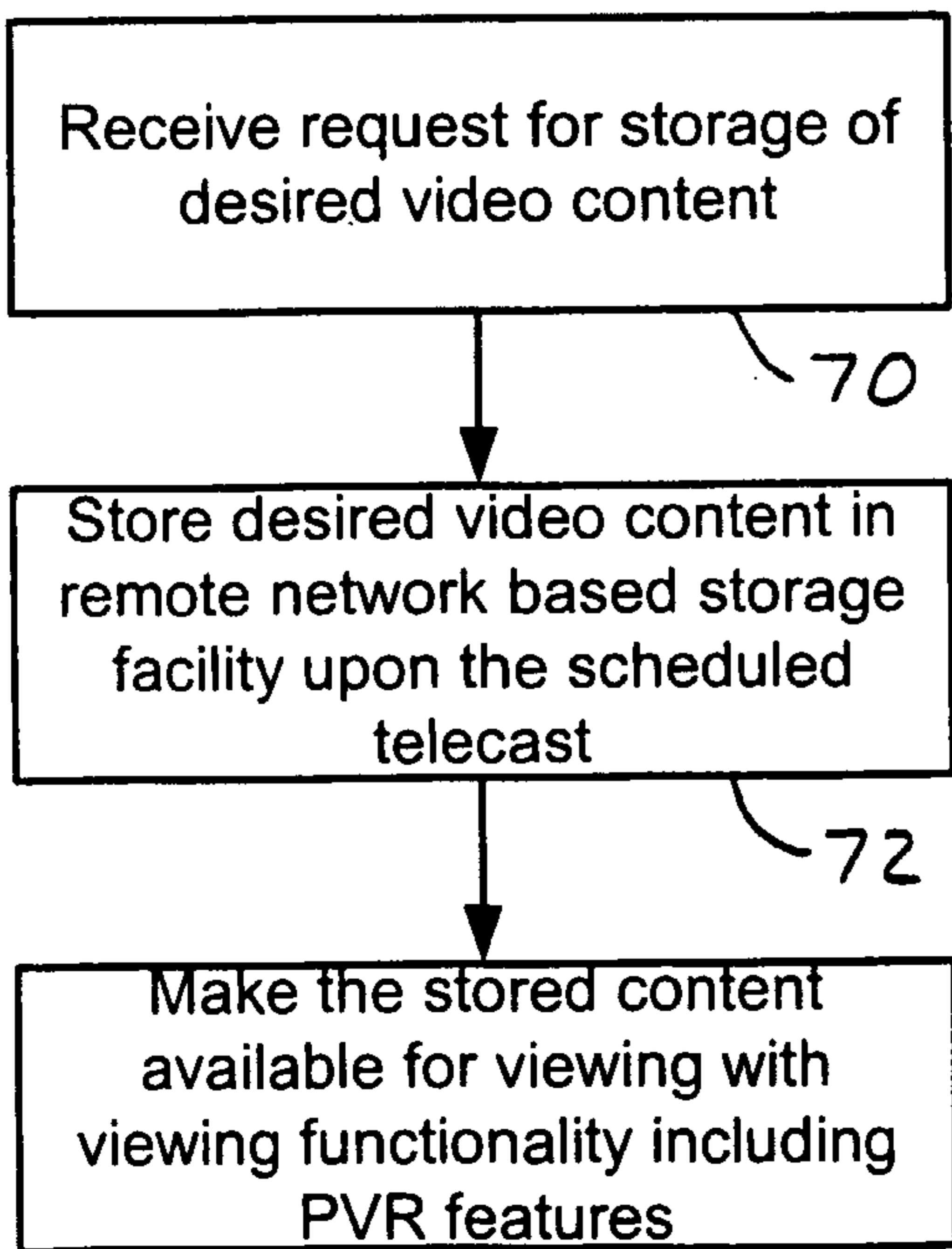

Fig. 4



66 Fig. 5



74 Fig. 6

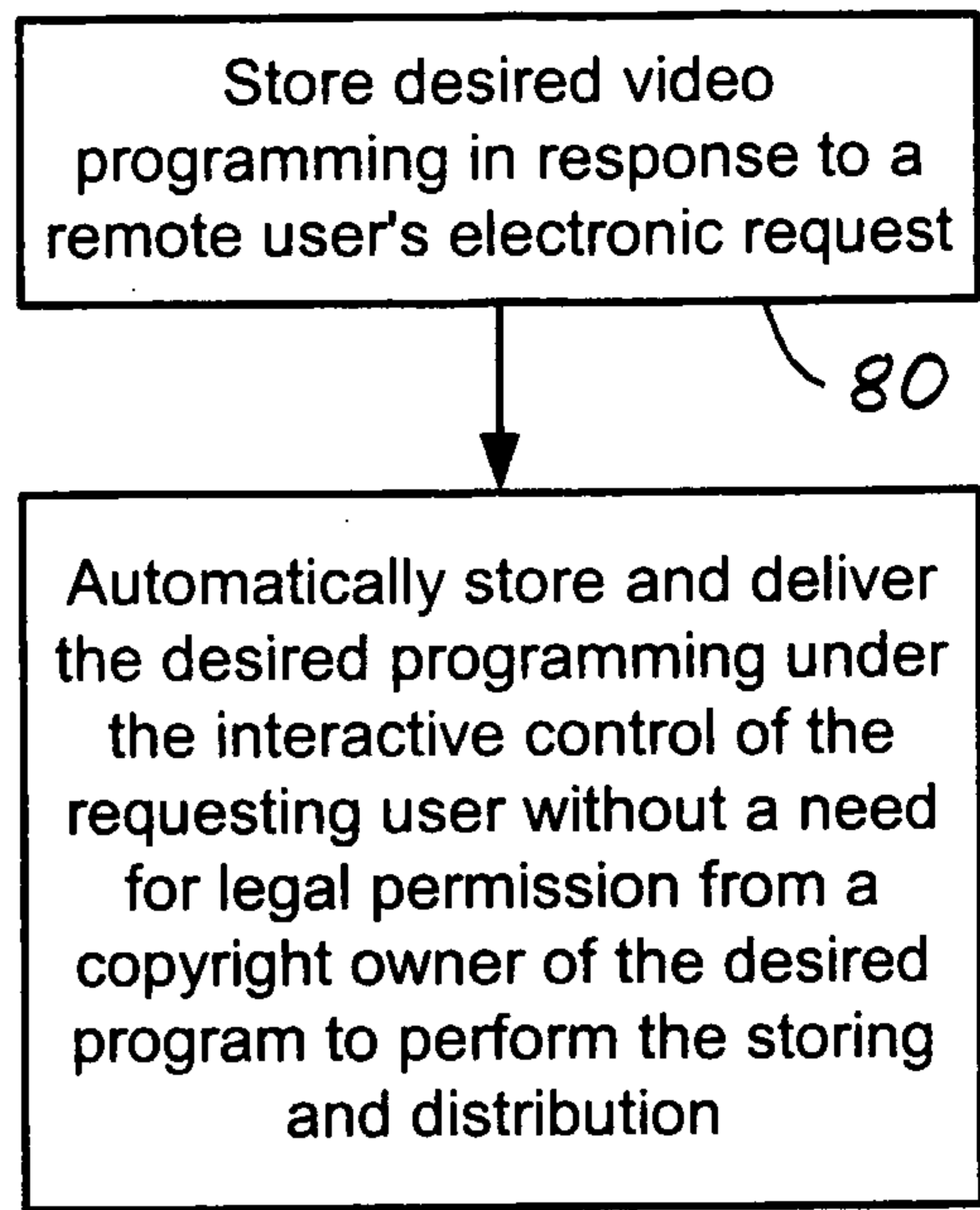

82 Fig. 7

