

(19) World Intellectual Property  
Organization  
International Bureau



(43) International Publication Date  
2 December 2004 (02.12.2004)

PCT

(10) International Publication Number  
**WO 2004/103619 A2**

- (51) International Patent Classification<sup>7</sup>: **B23B 31/20**,  
31/26
- (21) International Application Number:  
PCT/GB2004/002214
- (22) International Filing Date: 24 May 2004 (24.05.2004)
- (25) Filing Language: English
- (26) Publication Language: English
- (30) Priority Data:  
0311852.8 22 May 2003 (22.05.2003) GB
- (71) Applicant (for all designated States except US): **WEST-  
WIND AIR BEARINGS LTD** [GB/—]; Holton Road,  
Holton Heath, Poole, Dorset BH16 6KLN (GB).
- (72) Inventors; and
- (75) Inventors/Applicants (for US only): **PAVEY, Christo-  
pher, John** [GB/GB]; Yew Tree Lodge, 4 Ollivers Road,  
Colehill, Wimborne, Dorset BJ21 2NT (GB). **Tempest,  
Michael, Clinton** [GB/GB]; 8 Scarf Road, Canford Heath,  
Poole, Dorset HB17 8QQ (GB).
- (74) Agents: **FAULKNER, Thomas, John** et al.; FJ Cleveland,  
40-43 Chancery Lane, London WC2A 1JQ (GB).
- (81) Designated States (unless otherwise indicated, for every  
kind of national protection available): AE, AG, AL, AM,  
AT, AU, AZ, BA, BB, BG, BR, BW, BY, BZ, CA, CH, CN,  
CO, CR, CU, CZ, DE, DK, DM, DZ, EC, EE, EG, ES, FI,  
GB, GD, GE, GH, GM, HR, HU, ID, IL, IN, IS, JP, KE,  
KG, KP, KR, KZ, LC, LK, LR, LS, LT, LU, LV, MA, MD,  
MG, MK, MN, MW, MX, MZ, NA, NI, NO, NZ, OM, PG,  
PH, PL, PT, RO, RU, SC, SD, SE, SG, SK, SL, SY, TJ, TM,  
TN, TR, TT, TZ, UA, UG, US, UZ, VC, VN, YU, ZA, ZM,  
ZW.
- (84) Designated States (unless otherwise indicated, for every  
kind of regional protection available): ARIPO (BW, GH,  
GM, KE, LS, MW, MZ, NA, SD, SL, SZ, TZ, UG, ZM,  
ZW), Eurasian (AM, AZ, BY, KG, KZ, MD, RU, TJ, TM),  
European (AT, BE, BG, CH, CY, CZ, DE, DK, EE, ES, FI,  
FR, GB, GR, HU, IE, IT, LU, MC, NL, PL, PT, RO, SE, SI,

[Continued on next page]

(54) Title: ROTARY TOOL HOLDER ASSEMBLIE

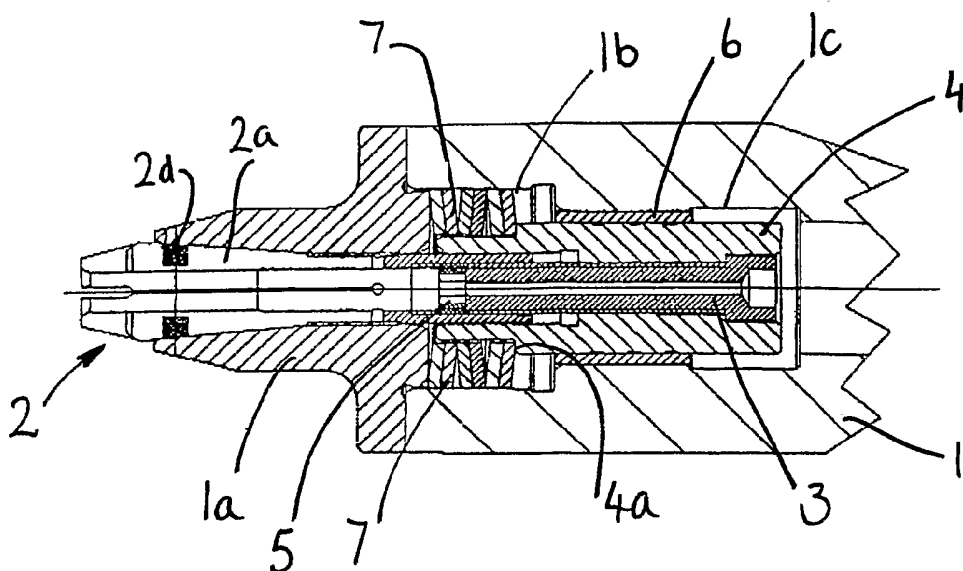

(57) Abstract: A rotary tool holder assembly comprising a collet (2) carried by a shaft (1). The collet (2) is moveable relative to the shaft (1) between a tool gripping position, in which an inserted tool can be gripped for rotation, and a tool release position. In some cases, the shaft (1) comprises a bore, an inner surface of which is shaped for contact with an outer surface of the collet (2). The shaft (1) and collet (2) are shaped such that when the rotary tool holder assembly is rotated at a predetermined high speed the shape of the inner surface of the shaft (1) substantially matches the shape of the outer surface of the collet (2). A friction reducing coating is provided between at least a portion of the inner surface of the shaft (1) and the outer surface of the collet (2). In alternatives, particular parts of the rotary tool holder may have a friction reducing coating.

WO 2004/103619 A2



SK, TR), OAPI (BF, BJ, CF, CG, CI, CM, GA, GN, GQ,  
GW, ML, MR, NE, SN, TD, TG).

*For two-letter codes and other abbreviations, refer to the "Guidance Notes on Codes and Abbreviations" appearing at the beginning of each regular issue of the PCT Gazette.*

**Declaration under Rule 4.17:**

— *of inventorship (Rule 4.17(iv)) for US only*

**Published:**

— *without international search report and to be republished upon receipt of that report*

### Rotary Tool Holder Assemblies

This invention relates to rotary tool holder assemblies, particularly rotary tool holder assemblies used in the printed circuit board manufacturing industry.

5 Typically, rotary tool holder assemblies are used in the printed circuit board manufacturing industry for high speed drilling or high speed machining using router bits.

Such rotary tool holders need a simple and effective means for gripping the  
10 tool for operation because of the high speeds of rotation used.

Because a relatively large number of tools will be used over time, rotary tool holders, and especially their mechanism for clamping and releasing tools are susceptible to wear.

15 Conventionally greases are used on surfaces within rotary tool holders which are liable to wear.

Furthermore, in at least some types of rotary tool holders, very low friction  
20 sliding between moving components within the tool holder can be important for providing a sufficiently strong grip on an inserted tool to allow proper operation. The provision of grease on the appropriate surfaces can at least initially provide the desired low friction between the sliding surfaces. However, if grease is lost or dries, the frictional forces will increase, impairing the  
25 performance of the rotary tool holder.

If the gripping force of a rotary tool holder reduces to the point where tool slippage occurs during use, damage can be caused to the tool holder assembly

and the tool. Typically a rotary tool holder assembly will comprise a collet in which the drill shank is held and this collet is particularly susceptible to damage. Other components in the rotary tool holder assembly can suffer fretting damage to their surfaces.

5

Greasing is almost universally used at present but has disadvantages. Firstly, whilst grease may be applied to almost any surface during the original manufacture of the tool holder, the further application of grease as part of a servicing operation can be difficult or impossible. Furthermore, in the high speed drilling and machining operations with which this application is particularly concerned, grease can be driven out from its desired location due to centrifugal effects.

Therefore, over the life of a rotary tool holder its performance can be significantly degraded due to wear and lack of lubrication.

15

It is an object of this invention to provide rotary tool holder assemblies which alleviate at least some of the problems associated with the prior art.

According to a first aspect of the present invention there is provided a rotary tool holder assembly for high speed rotation comprising a collet and a shaft, the collet being moveable relative to the shaft between a tool gripping position, in which an inserted tool can be gripped for rotation, and a tool release position, the shaft comprising a bore for receiving the collet, an inner surface of the shaft being shaped for contact with an outer surface of the collet, the shaft and collet shaped such that when the rotary tool holder assembly is rotated at a predetermined high speed the shape of the inner surface of the shaft substantially matches the shape of the outer surface of the collet and

20  
25

wherein a friction reducing coating is provided between at least a portion of the inner surface of the shaft and the outer surface of the collet.

According to a second aspect of the present invention there is provided a rotary  
5 tool holder assembly comprising:

a collet carried by a shaft, the collet being moveable relative to the shaft  
between a tool gripping position, in which an inserted tool can be gripped for  
rotation, and a tool release position; and  
spring means disposed in a spring receiving bore for biasing the collet towards  
10 the gripping position, a friction reducing coating being provided between at  
least a portion of the spring means and the spring receiving bore.

According to a third aspect of the present invention there is provided a rotary  
tool holder assembly comprising a collet carried by a shaft, wherein the collet  
15 is moveable relative to the shaft between a tool gripping position in which an  
inserted tool can be gripped for rotation and a tool release position, the collet is  
carried by a bobbin arranged for axial movement within a bore of the shaft and  
a friction reducing coating is provided between at least a portion of the bobbin  
and the bore of the shaft.

20

In this specification, a friction reducing coating is a coating which gives rise to  
a lower frictional force between relatively moving parts than would occur if the  
coating were not present.

25 The rotary tool holder will typically be arranged for high speed rotation which  
would typically be in excess of 80,000 rpm. The tool to be gripped will  
typically be a drill bit or a router bit.

Preferably, at least one portion of the collet is coated with a friction reducing coating.

In one set of embodiments, the shaft comprises a bore for receiving the collet.

- 5 At least part of an outer surface of the collet which faces the internal surface of the shaft bore may be coated with a friction reducing coating. Part or all of the internal surface of the shaft bore may be coated with a friction reducing coating.

- 10 The collet may comprise a plurality of jaw portions for gripping an inserted tool. Typical numbers of jaw portions are three, four, six or eight.

- The collet and/or shaft may be tapered so that axial movement of the collet relative to the shaft causes or allows the jaw portions of the collet to move in a  
15 direction transverse to the axis of the collet for gripping and releasing of an inserted tool. Preferably the tapering is such as to force the jaw portions into gripping contact with an inserted tool under movement of the collet relative to the shaft in one direction and the collet is arranged so that the jaw portions are biased away from gripping contact, so that an inserted tool will tend to be  
20 released as the result of movement of the collet relative to the shaft in the opposite direction.

- The taper surfaces of the collet and/or the shaft may be coated with a friction reducing coating. It is particularly preferred for some or all of the taper surface  
25 of the collet to be coated with a friction reducing coating. In cases where both the collet and the shaft have tapers, the taper angle of the collet may be greater than the taper angle of the shaft. The taper angle is the acute angle of the taper relative to the axis about which the tool holder assembly is arranged for

rotation. The difference in taper angle between the taper of the shaft and the taper of the collet may be between 1 and 10 arc minutes.

5 The collet will typically be generally cylindrical and substantially the whole of the outer curved surface of the cylinder may be coated with the friction reducing coating.

10 The shaft will typically be arranged to be journalled in a tooling machine. The surfaces of the shaft which are arranged to be received in the bearing(s) of the tooling machine may be coated with a friction reducing coating.

15 In one set of embodiments the collet may be carried by a bobbin arranged for axial movement within the bore of the shaft. The collet may be carried on the bobbin by virtue of being mounted on a stud retained within the bobbin. A guidebush insert may be provided within the bore of the shaft and the bobbin arranged for axial movement within the guide bush. Spring means may be provided for biasing the collet towards the gripping position. The spring means may be arranged for acting on the bobbin to bias the collet towards the gripping position. The spring means may be disposed in a spring receiving bore  
20 which may be provided in the shaft.

25 At least a portion of one of, or any combination of, the following components may be coated with a friction reducing coating: the bobbin, the guide bush, the spring means, the spring receiving bore.

In one embodiment each surface of each component of the assembly that moves in contact with the surface of another assembly component during the insertion and/or release of a tool is coated with a friction reducing coating.

Preferably the internal surface of the collet, and especially the inner tool gripping surfaces of the jaw portions of the collet are kept free of friction reducing coating.

- 5 The coating preferably has a very low coefficient of friction, say in the region of 0.1 or lower.

Preferably the coating is applied to parts using a low temperature process to avoid changing the properties of the materials of the coated components. The  
10 process may be conducted at room temperature.

Preferably the coating is thin. More preferably still, the coating is sufficiently thin that the coating may be applied after the finishing processes have been carried out on the components and, after coating, the components remain within  
15 the selected manufacturing tolerances.

Preferably the coating is applied evenly over the coated surfaces. This can ensure that the geometry of the components is maintained and there is no edge build up of coating material. The coating is preferably useable on heat treated  
20 materials without damage.

The coating is preferably compatible with at least one of, or any combination of: solvents, lubricating oils and greases.

- 25 The coating preferably has sufficient hardness to resist handling damage. The coating may have a hardness in the region of 30 Rc (Rockwell Hardness scale C).

The coating may be a tungsten di-sulphide coating.

According to a fourth aspect of the present invention there is provided a method of manufacturing a rotary tool holder assembly comprising a collet  
5 carried by a shaft, wherein the collet is moveable relative to the shaft between a tool gripping position, in which an inserted tool can be gripped for rotation, and a tool release position, and a spring means disposed in a spring receiving bore for biasing the collet towards the gripping position the method comprising the steps of machining and finishing a plurality of component parts of the  
10 assembly within selected manufacturing tolerances and after the machining and finishing steps, applying a friction reducing coating between at least one portion of the spring means and the spring receiving bore without causing the dimensions of the coated component to fall outside of the selected tolerances.

15 According to a fifth aspect of the present invention there is provided a method of manufacturing a rotary tool holder assembly comprising a collet carried by a shaft, wherein the collet is moveable relative to the shaft between a tool gripping position, in which an inserted tool can be gripped for rotation, and a tool release position, and the collet is carried by a bobbin arranged for axial  
20 movement within the bore of the shaft, the method comprising the steps of machining and finishing a plurality of component parts of the assembly within selected manufacturing tolerances and after the machining and finishing steps, applying a friction reducing coating between at least one portion of the bobbin and the bore of the shaft without causing the dimensions of the coated  
25 component to fall outside of the selected tolerances.

According to a sixth aspect of the present invention there is provided a rotary tool holder comprising:

a collet carried by a shaft, the collet being moveable relative to the shaft between a tool gripping position, in which an inserted tool can be gripped for rotation, and a tool release position; and  
spring means disposed in a spring receiving bore for biasing the collet towards  
5 the gripping position, a friction reducing coating being provided between at least a portion of the spring means and the spring receiving bore,  
wherein the collet is carried by a bobbin arranged for axial movement within a bore of the shaft, a friction reducing coating being provided between at least a portion of the bobbin and the bore of the shaft.

10

According to a seventh aspect of the present invention there is provided a rotary tool holder comprising:

a collet carried by a shaft, the collet being moveable relative to the shaft between a tool gripping position, in which an inserted tool can be gripped for  
15 rotation, and a tool release position; and

a spring disposed in a spring receiving bore for biasing the collet towards the gripping position, a friction reducing coating being provided between at least a portion of the spring and the spring receiving bore,

20 wherein the collet is carried by a bobbin arranged for axial movement within a bore of the shaft, a friction reducing coating being provided between at least a portion of the bobbin and the bore of the shaft.

According to an eighth aspect of the present invention there is provided a A rotary tool holder comprising:

25 a collet carried by a shaft, the collet being moveable relative to the shaft between a tool gripping position, in which an inserted tool can be gripped for rotation, and a tool release position; and  
means for biasing the collet towards the gripping position disposed in a

receiving bore, a friction reducing coating being provided between at least a portion of the means for biasing the collet and the receiving bore, wherein the collet is carried by a bobbin arranged for axial movement within a bore of the shaft, a friction reducing coating being provided between at least a portion of the bobbin and the bore of the shaft.

Embodiments of the present invention will now be described, by way of example only, with reference to the accompanying drawings in which:

10 Figure 1 is a sectional view of part of a rotary tool holder assembly;

Figure 1A is a schematic representation of part of the rotary tool holder shown in Figure 1;

15 Figure 2 is a sectional view of a collet of the rotary tool holder assembly shown in Figure 1; and

Figure 3 is an isometric view of the collet shown in Figure 2.

20 Figure 1 shows a rotary tool holder assembly which comprises a shaft 1 which carries a collet 2 for holding a tool (not shown). The collet 2 is arranged for movement within the shaft 1 between a gripping position in which an inserted tool is firmly gripped for rotation and a release position in which the tool may be relatively easily inserted into and removed from the collet 2.

25

The release position corresponds to the collet 2 projecting further out of the shaft 1 and the gripping position corresponds to the collet 2 being drawn back into the shaft 1. That is to say movement of the collet 2 towards the left in the

orientation shown in Figure 1 will release the gripping force on an inserted tool, whereas movement to the right will increase the gripping force on an inserted tool.

- 5 As is perhaps most clearly seen in Figure 3, the collet 2 is of generally cylindrical shape and although not shown in the drawings the shaft 1 similarly has a generally cylindrical shape.

10 As best seen in Figure 3, the collet 2 in this embodiment comprises four jaw portions 2a which are arranged for gripping an inserted tool. Slots 2b terminating in stress relieving apertures 2c are provided in the body of the collet 2 to allow the jaw portions 2a to flex relative to the remainder of the collet 2. In other embodiments there may be differing numbers of jaws, for example there may be three, six or eight jaw portions.

15

A central portion of each jaw portion 2a carries an external taper which mates with an internal taper in a front portion 1a of the shaft 1. When the collet 2 is moved axially relative to the shaft 2 these tapers interact to cause the jaws 2a to move closer to one another, to grip an inserted tool, as the collet 2 is moved into the shaft 1 and similarly allow the jaw portions 2a to move away from one another, to release an inserted tool, as the collet 2 is moved further out of the shaft 1.

20

Rubber inserts 2d (not shown in Figure 3) are provided in each of the jaw portions 2a to bear on the internal taper of the front portion 1a of the shaft 1. These inserts provide a dust seal to prevent or limit the ingress of dust into the assembly via the slots 2b.

25

The body of the shaft 1 comprises a main bore which has two portions of different diameter. The first portion of the bore is adjacent to the front portion 1a of the shaft and has a diameter which is larger than the diameter of the second portion of the bore 1c which is disposed further into the body of the shaft 1.

The collet 2 is threadingly mounted on a threaded stud 3, which itself is retained in a bobbin 4 arranged for movement within the shaft 1. The collet 2 is threaded onto the stud 3 during assembly and is locked in position using a locking grub screw 5. Thus in normal operation the collet 2, stud 3 and bobbin 4 move together relative to the shaft 1.

The collet 2, stud 3 and bobbin 4 are housed within the second portion of the main bore 1c of the shaft 1. A guide bush insert 6 is provided within the bore of the shaft 1 and is arranged to guide the movement of the bobbin 4 and hence the collet 2.

The first part of the main bore 1b houses a set of springs 7 which act on a shoulder 4a of the bobbin. The springs 7 are put under compression during assembly so that the springs 7 tend to drive the bobbin 4 further into the shaft 1 so retracting the collet 2. As described above, due to the mating tapers of the collet 2 and front portion 1a of the shaft, retraction of the collet 2 causes the collet jaw portions 2a to grip an inserted tool.

Therefore, when a tool is to be inserted into the rotary tool holder, a push rod is used to push the bobbin 4, and hence collet 2, forward such that the jaw portions 2a of the collet may spread to allow the insertion of a tool. When the force of the push rod is removed, the collet 2 and bobbin 4 retract under force

of the springs 7 into the shaft 1 causing the jaws 2a to close onto and grip the inserted tool.

It will be noticed that during the movement of the bobbin 4, stud 3 and collet 2  
5 relative to the shaft 1, there are various components which are in sliding contact with one another.

This has two implications. First of all these components are susceptible to wear and, secondly the frictional force between these sliding components must be  
10 kept to a minimum if a good gripping force is to be exerted on an inserted tool.

In the present embodiment, to give good wear characteristics and maximise the gripping force which is exerted on an inserted tool, components within the tool  
15 holder assembly are coated with a friction reducing coating.

In particular, the outer curved surfaces of the collet 2 are provided with a friction reducing coating.

20 Other surfaces in the tool holder assembly can also be coated with a friction reducing coating. These surfaces include: the internal curved surface of the guide bush insert 6; the taper surfaces of the front portion 1a of the shaft; the outer cylindrical surface of the bobbin 4; the internal cylindrical surface of the first part of the main bore 1b which houses the springs 7; and the whole of the  
25 surfaces of the springs 7, or at least those parts which come into contact with the bobbin 4 and/or the internal cylindrical surface of the first part of the main bore 1b.

On the other hand however, the internal cylindrical surface of the collet 2 and especially the internal surface of the jaw portions 2a is kept clean of friction reducing coating to ensure that maximum grip is exerted on an inserted tool.

5 The provision of friction reducing coating on these components, and first foremost on the external curved surfaces of the collet 2, in particular the taper surfaces of the collet 2, can give rise to a very low maintenance product which will retain a high gripping force on an inserted tool over a long period of time without the need for any regreasing.

10

The friction reducing coating should have a low coefficient of friction, preferably a very low coefficient of friction of in the region of 0.1 or lower. It is preferred that the friction reducing coating can be applied to parts using a low temperature application process, for example a room temperature application process. This is to avoid changing the material properties or conditions of the components during coating.

15

The coating is preferably thin, and in a preferred manufacturing process, the components are machined and finished to the desired size within chosen manufacturing tolerances and the friction reducing coating is then applied to the relevant surfaces of the components whilst staying within the manufacturing tolerances. Compared with the typical assembly tolerances (of say 2.5 microns on diameter) in devices of interest, the coating should be thin and say in the order of 0.5 microns or less.

20

The coating should follow the geometry of the existing machined surfaces and exhibit no edge build up.

25

The coating should be usable on heat treated materials without damage and, furthermore, should be compatible with solvents, lubricating oils and greases which may be used deliberately or may come into contact with the coated surfaces during assembly or use.

5

The coating needs to have a reasonable degree of hardness to resist handling damage. A hardness of 30 Rc (Rockwell hardness scale C) or greater is considered to be appropriate.

10 In preferred embodiments of the present invention the coating is a tungsten disulphide coating.

Although not shown in the drawings, the rotary tool holder assembly will be arranged to be received in a tooling machine for rotary drive. The shaft 1  
15 therefore has journal surfaces to be received in appropriate rotary bearings and these journal surfaces can be coated with a friction reducing coating to give low friction starting and anti-scuffing where air bearings are used, and to generally assist with bearing lubrication where mechanical bearings are used.

20 In an alternative embodiment, the rotary tool holder described above with reference to Figures 1 to 3 includes a tapering mis-match between the external tapers of the jaw portions 2a and the internal taper of the front portion 1a of the shaft 1. This mis-match even if it were shown in Figure 1 would not be readily discernable because the amount of mis-match is small compared to the  
25 dimensions of the components shown in Figure 1. This mis-match may, however, be seen in Figure 1A, which is a schematic representation of part of the rotary tool holder shown in Figure 1, but modified to include the tapering mis-match of this alternative embodiment.

Figure 1A shows part of the rotary tool holder in a stationary configuration. In this configuration the taper angle of the internal taper of the shaft 1 (which is the acute angle formed between the internal taper and the axis of the shaft) is less than the taper angle of the jaw portions 2a. The difference between the taper angle of the shaft and the taper angle of the jaw portions 2a is typically several arc minutes. Thus when the rotary tool holder is stationary the internal taper of the shaft 1 has only line contact with the taper of the jaw portions 2a at the very front of the shaft.

When the rotary tool holder is in use, it is typically rotated in excess of 80,000 rpm. At these speeds the shaft 1 tends to expand radially. This effect tends to be more pronounced towards the front end 1a of the shaft 1 where the shaft 1 is thinner. As the shaft 1 expands, it changes shape such that the mis-match between the internal taper of the shaft 1 and the external taper of the jaw portions 2a decreases. In preferred embodiments, the arrangement is such that the mis-match disappears and the taper of the shaft and the external taper of the jaw portions 2a become the same as one another. During this process, the jaw portions 2a are urged axially into the narrow end of the internal taper of the shaft by the springs 7 causing the collet 2 to slide relative to the shaft 1. The shape of the jaw portions 2a also changes as a result of rotation and so the tapers are ideally chosen with this in mind.

The presence of the friction reducing coating on the external taper of the jaw portions and the internal taper of the shaft is advantageous as the contact forces between the front portion 1a of the shaft 1 and the jaw portions 2a are initially very high due to the small area of contact. The friction reducing coating tends to allow the collet 2 to move relative to the shaft 1 without jamming or fretting of the surfaces.

## CLAIMS:

1. A rotary tool holder assembly for high speed rotation comprising a collet and a shaft, the collet being moveable relative to the shaft between a tool gripping position, in which an inserted tool can be gripped for rotation, and a tool release position, the shaft comprising a bore for receiving the collet, the shaft and collet shaped such that when the rotary tool holder assembly is rotated at a high speed the inner surface of the shaft bore substantially fits the outer surface of the collet.
2. A rotary tool holder according to claim 1 wherein at least one of the shaft and the collet are arranged such that when the rotary tool holder assembly is rotated at the high speed there is relative deformation between the outer surface of the collet and the inner surface of the shaft bore to give the substantial fit therebetween.
3. A rotary tool holder according to claim 1 or claim 2 wherein a friction reducing coating is provided between at least a portion of the inner surface of the shaft and the outer surface of the collet.
4. A rotary tool holder according to any preceding claim wherein the outer surface of the collet and the inner surface of the shaft are tapered, the collet and the shaft bore tapering inwardly away from a tool receiving mouth of the collet.
5. A rotary tool holder according to claim 4 wherein, when the rotary tool holder is stationary, the taper angle of the collet is greater than the taper angle of the shaft.

6. A rotary tool holder according to claim 5 wherein the difference in taper angle between the inner surface of the shaft and the outer surface of the collet is between 1 and 10 arc minutes.
- 5 7. A rotary tool holder assembly according to any preceding claim in which at least a portion of one of the collet and the inner surface of the shaft bore is coated with a friction reducing coating, and preferably at least part of an outer surface of the collet which faces the inner surface of the shaft bore is coated with a friction reducing coating.
- 10 8. A rotary tool holder assembly according to claim 1 in which the collet comprises a plurality of jaw portions for gripping an inserted tool, at least one of the collet and the shaft are tapered so that axial movement of the collet relative to the shaft causes or allows the jaw portions of the collet to move in a  
15 direction transverse to the axis of the collet for gripping and releasing of an inserted tool.
9. A rotary tool holder assembly according to any preceding claim in which the collet is generally cylindrical and substantially the whole of the outer  
20 curved surface of the cylinder is coated with the friction reducing coating.
10. A rotary tool holder assembly according to any preceding claim in which the shaft is arranged to be journalled in a tooling machine and surfaces of the shaft which are arranged to be received in the bearing of the tooling  
25 machine are at least partially coated with a friction reducing coating.
11. A rotary tool holder assembly according to any preceding claim in which the collet is carried by a bobbin arranged for axial movement within a

bore of the shaft.

12. A rotary tool holder assembly according to claim 11 in which at least a portion of the bobbin is coated with a friction reducing coating.

5

13. A rotary tool holder assembly according to claim 11 or claim 12 in which the collet is carried on the bobbin by virtue of being mounted on a stud retained within the bobbin.

10 14. A rotary tool holder assembly according to claim 11, claim 12 or claim 13 in which a guidebush insert is provided within the bore of the shaft and the bobbin is arranged for axial movement within the guide bush.

15 15. A rotary tool holder assembly according to claim 14 in which at least a portion of the guidebush is coated with a friction reducing coating.

16. A rotary tool holder assembly according to any preceding claim in which spring means are provided for biasing the collet towards the gripping position.

20

17. A rotary tool holder assembly according to any one of claims 11 to 15 comprising spring means arranged for acting on the bobbin to bias the collet towards the gripping position.

25 18. A rotary tool holder assembly according to claim 16 or claim 17 in which at least a portion of the spring means is coated with a friction reducing coating.

19. A rotary tool holder assembly according to any one of claims 16 to 18 in which the spring means is disposed in a spring receiving bore which is provided in the shaft.
- 5 20. A rotary tool holder assembly according to claim 19 in which at least a portion of the spring receiving bore is coated with a friction reducing coating.
21. A rotary tool holder assembly according to any preceding claim in which each surface of each component of the assembly that moves in contact  
10 with the surface of another assembly component during the insertion and/or release of a tool is coated with a friction reducing coating.
22. A rotary tool holder assembly according to any preceding claim in which the coating has a very low coefficient of friction.
- 15 23. A rotary tool holder assembly according to any preceding claim in which the coating is applied to parts using a low temperature process to avoid changing the properties of the materials of the coated components.
- 20 24. A rotary tool holder assembly according to any preceding claim in which the coating is sufficiently thin that the coating may be applied after the finishing processes have been carried out on the components and, after coating, the components remain within selected manufacturing tolerances.
- 25 25. A rotary tool holder assembly according to any preceding claim in which the coating is useable on heat treated materials without damage.
26. A rotary tool holder assembly according to any preceding claim in

which the coating is compatible with at least one of, or any combination of: solvents, lubricating oils and greases.

27. A rotary tool holder assembly according to any preceding claim in  
5 which the coating has a hardness in the region of 30 Rc (Rockwell Hardness scale C).

28. A rotary apparatus comprising a rotary tool holder according to any  
preceding claim and a tooling machine wherein the predetermined high speed is  
10 the maximum operational speed of the tooling machine.

29. A rotary tool holder assembly comprising:  
a collet carried by a shaft, the collet being moveable relative to the shaft  
between a tool gripping position, in which an inserted tool can be gripped for  
15 rotation, and a tool release position; and  
spring means disposed in a spring receiving bore for biasing the collet towards  
the gripping position, a friction reducing coating being provided between at  
least a portion of the spring means and the spring receiving bore.

20 30. A rotary tool holder assembly according to claim 29 which is arranged  
for high speed rotation.

31. A rotary tool holder assembly according to claim 29 or claim 30 in  
which at least one portion of the collet is coated with a friction reducing  
25 coating.

32. A rotary tool holder assembly according to any one of claims 29 to 31  
in which the shaft comprises a bore for receiving the collet and at least part of

an outer surface of the collet which faces the internal surface of the shaft bore is coated with a friction reducing coating.

5 33. A rotary tool holder assembly according to claim 32 in which at least part of the internal surface of the shaft bore is coated with a friction reducing coating.

10 34. A rotary tool holder assembly according to any one of claims 29 to 33 in which the collet comprises a plurality of jaw portions for gripping an inserted tool, at least one of the collet and the shaft are tapered so that axial movement of the collet relative to the shaft causes or allows the jaw portions of the collet to move in a direction transverse to the axis of the collet for gripping and releasing of an inserted tool and at least some of the taper surfaces of the collet and/or the shaft are coated with a friction reducing  
15 coating.

20 35. A rotary tool holder assembly according to any one of claims 29 to 34 in which the collet comprises taper surfaces which are coated with a friction reducing coating.

25 36. A rotary tool holder assembly according to any one of claims 29 to 35 in which the collet is generally cylindrical and substantially the whole of the outer curved surface of the cylinder is coated with the friction reducing coating.

37. A rotary tool holder assembly according to any one of claims 29 to 36 in which the shaft is arranged to be journalled in a tooling machine and surfaces of the shaft which are arranged to be received in the bearing of the

tooling machine are at least partially coated with a friction reducing coating.

38. A rotary tool holder assembly according to any one of claims 29 to 37  
in which the collet is carried by a bobbin arranged for axial movement within a  
5 bore of the shaft.

39. A rotary tool holder assembly according to claim 38 in which at least a  
portion of the bobbin is coated with a friction reducing coating.

10 40. A rotary tool holder assembly according to claim 38 or claim 39 in  
which the collet is carried on the bobbin by virtue of being mounted on a stud  
retained within the bobbin.

41. A rotary tool holder assembly according to claim 38, claim 39 or claim  
15 40 in which a guidebush insert is provided within the bore of the shaft and the  
bobbin is arranged for axial movement within the guide bush.

42. A rotary tool holder assembly according to claim 41 in which at least a  
portion of the guidebush is coated with a friction reducing coating.

20

43. A rotary tool holder assembly according to any one of claims 38 to 42  
in which the spring means is arranged for acting on the bobbin to bias the  
collet towards the gripping position.

25 44. A rotary tool holder according to any one of claims 29 to 43 wherein at  
least a portion of the spring means is coated with a friction reducing coating.

45. A rotary tool holder assembly according to claim 44 in which at least a

portion of the spring receiving bore is coated with a friction reducing coating.

46. A rotary tool holder assembly according to any one of claims 29 to 45  
in which each surface of each component of the assembly that moves in  
5 contact with the surface of another assembly component during the insertion  
and/or release of a tool is coated with a friction reducing coating.

47. A rotary tool holder assembly according to any one of claims 29 to 46  
in which the coating has a very low coefficient of friction.

10

48. A rotary tool holder assembly according to any one of claims 29 to 47  
in which the coating is applied to parts using a low temperature process to  
avoid changing the properties of the materials of the coated components.

15 49. A rotary tool holder assembly according to any one of claims 29 to 48  
in which the coating is sufficiently thin that the coating may be applied after  
the finishing processes have been carried out on the components and, after  
coating, the components remain within selected manufacturing tolerances.

20 50. A rotary tool holder assembly according to any one of claims 29 to 49  
in which the coating is useable on heat treated materials without damage.

51. A rotary tool holder assembly according to any one of claims 29 to 50  
in which the coating is compatible with at least one of, or any combination of:  
25 solvents, lubricating oils and greases.

52. A rotary tool holder assembly according to any one of claims 29 to 51  
in which the coating has a hardness in the region of 30 Rc (Rockwell Hardness

scale C).

53. A rotary tool holder assembly comprising a collet carried by a shaft, wherein the collet is moveable relative to the shaft between a tool gripping  
5 position in which an inserted tool can be gripped for rotation and a tool release position, the collet is carried by a bobbin arranged for axial movement within a bore of the shaft and a friction reducing coating is provided between at least a portion of the bobbin and the bore of the shaft.

10 54. A rotary tool holder assembly according to claim 53 which is arranged for high speed rotation.

15 55. A rotary tool holder assembly according to claim 53 or claim 54 in which at least one portion of the collet is coated with a friction reducing coating.

20 56. A rotary tool holder assembly according to any one of claims 53 to 55 in which the shaft comprises a bore for receiving the collet and at least part of an outer surface of the collet which faces the internal surface of the shaft bore is coated with a friction reducing coating.

25 57. A rotary tool holder assembly according to claim 56 in which at least part of the internal surface of the shaft bore is coated with a friction reducing coating.

58. A rotary tool holder assembly according to any one of claims 53 to 57 in which the collet comprises a plurality of jaw portions for gripping an inserted tool, at least one of the collet and the shaft are tapered so that axial

movement of the collet relative to the shaft causes or allows the jaw portions of the collet to move in a direction transverse to the axis of the collet for gripping and releasing of an inserted tool and at least some of the taper surfaces of the collet and/or the shaft are coated with a friction reducing coating.

59. A rotary tool holder assembly according to any one of claims 53 to 58 in which the collet comprises taper surfaces which are coated with a friction reducing coating.

60. A rotary tool holder assembly according to any one of claims 53 to 59 in which the collet is generally cylindrical and substantially the whole of the outer curved surface of the cylinder is coated with the friction reducing coating.

61. A rotary tool holder assembly according to any one of claims 53 to 60 in which the shaft is arranged to be journalled in a tooling machine and surfaces of the shaft which are arranged to be received in the bearing of the tooling machine are at least partially coated with a friction reducing coating.

62. A rotary tool holder assembly according to any one of claims 53 to 61 in which the collet is carried on the bobbin by virtue of being mounted on a stud retained within the bobbin.

63. A rotary tool holder assembly according to any one of claims 63 to 62 in which at least a portion of the bobbin is coated with a friction reducing coating.

64. A rotary tool holder assembly according to any one of claims 53 to 63

in which a guidebush insert is provided within the bore of the shaft and the bobbin is arranged for axial movement within the guide bush.

5 65. A rotary tool holder assembly according to claim 64 in which at least a portion of the guidebush is coated with a friction reducing coating.

66. A rotary tool holder assembly according to any one of claims 53 to 65 in which spring means are provided for biasing the collet towards the gripping position.

10

67. A rotary tool holder assembly according to any one of claims 53 to 66 comprising spring means arranged for acting on the bobbin to bias the collet towards the gripping position.

15 68. A rotary tool holder assembly according to claim 66 or claim 67 in which at least a portion of the spring means is coated with a friction reducing coating.

20 69. A rotary tool holder assembly according to any one of claims 66 to 68 in which the spring means is disposed in a spring receiving bore which is provided in the shaft.

70. A rotary tool holder assembly according to claim 69 in which at least a portion of the spring receiving bore is coated with a friction reducing coating.

25

71. A rotary tool holder assembly according to any one of claims 53 to 70 in which each surface of each component of the assembly that moves in contact with the surface of another assembly component during the insertion

and/or release of a tool is coated with a friction reducing coating.

72. A rotary tool holder assembly according to any one of claims 53 to 71 in which the coating has a very low coefficient of friction.

5

73. A rotary tool holder assembly according to any one of claims 53 to 72 in which the coating is applied to parts using a low temperature process to avoid changing the properties of the materials of the coated components.

10 74. A rotary tool holder assembly according to any one of claims 53 to 73 in which the coating is sufficiently thin that the coating may be applied after the finishing processes have been carried out on the components and, after coating, the components remain within selected manufacturing tolerances.

15 75. A rotary tool holder assembly according to any one of claims 53 to 74 in which the coating is useable on heat treated materials without damage.

20 76. A rotary tool holder assembly according to any one of claims 53 to 75 in which the coating is compatible with at least one of, or any combination of: solvents, lubricating oils and greases.

25 77. A rotary tool holder assembly according to any one of claims 53 to 76 in which the coating has a hardness in the region of 30 Rc (Rockwell Hardness scale C).

78. A method of manufacturing a rotary tool holder assembly comprising a collet carried by a shaft, wherein the collet is moveable relative to the shaft between a tool gripping position, in which an inserted tool can be gripped for

rotation, and a tool release position, and a spring means disposed in a spring receiving bore for biasing the collet towards the gripping position the method comprising the steps of machining and finishing a plurality of component parts of the assembly within selected manufacturing tolerances and after the  
5 machining and finishing steps, applying a friction reducing coating between at least one portion of the spring means and the spring receiving bore without causing the dimensions of the coated component to fall outside of the selected tolerances.

10 79. A method of manufacturing a rotary tool holder assembly comprising a collet carried by a shaft, wherein the collet is moveable relative to the shaft between a tool gripping position, in which an inserted tool can be gripped for rotation, and a tool release position, and the collet is carried by a bobbin arranged for axial movement within the bore of the shaft, the method  
15 comprising the steps of machining and finishing a plurality of component parts of the assembly within selected manufacturing tolerances and after the machining and finishing steps, applying a friction reducing coating between at least one portion of the bobbin and the bore of the shaft without causing the dimensions of the coated component to fall outside of the selected tolerances.

20

80. A rotary tool holder comprising:  
a collet carried by a shaft, the collet being moveable relative to the shaft between a tool gripping position, in which an inserted tool can be gripped for rotation, and a tool release position; and  
25 spring means disposed in a spring receiving bore for biasing the collet towards the gripping position, a friction reducing coating being provided between at least a portion of the spring means and the spring receiving bore,  
wherein the collet is carried by a bobbin arranged for axial movement within a

bore of the shaft, a friction reducing coating being provided between at least a portion of the bobbin and the bore of the shaft.

81. A rotary tool holder comprising:

- 5 a collet carried by a shaft, the collet being moveable relative to the shaft between a tool gripping position, in which an inserted tool can be gripped for rotation, and a tool release position; and  
a spring disposed in a spring receiving bore for biasing the collet towards the gripping position, a friction reducing coating being provided between at least a  
10 portion of the spring and the spring receiving bore,  
wherein the collet is carried by a bobbin arranged for axial movement within a bore of the shaft, a friction reducing coating being provided between at least a portion of the bobbin and the bore of the shaft.

15 82. A rotary tool holder comprising:

- a collet carried by a shaft, the collet being moveable relative to the shaft between a tool gripping position, in which an inserted tool can be gripped for rotation, and a tool release position; and  
means for biasing the collet towards the gripping position disposed in a  
20 receiving bore, a friction reducing coating being provided between at least a portion of the means for biasing the collet and the receiving bore,  
wherein the collet is carried by a bobbin arranged for axial movement within a bore of the shaft, a friction reducing coating being provided between at least a portion of the bobbin and the bore of the shaft.

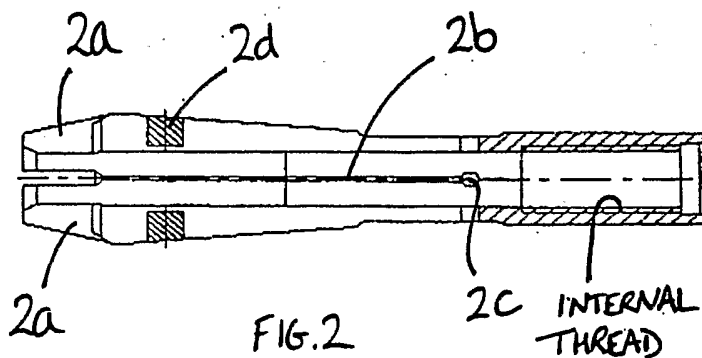
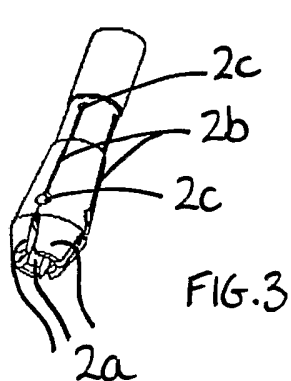
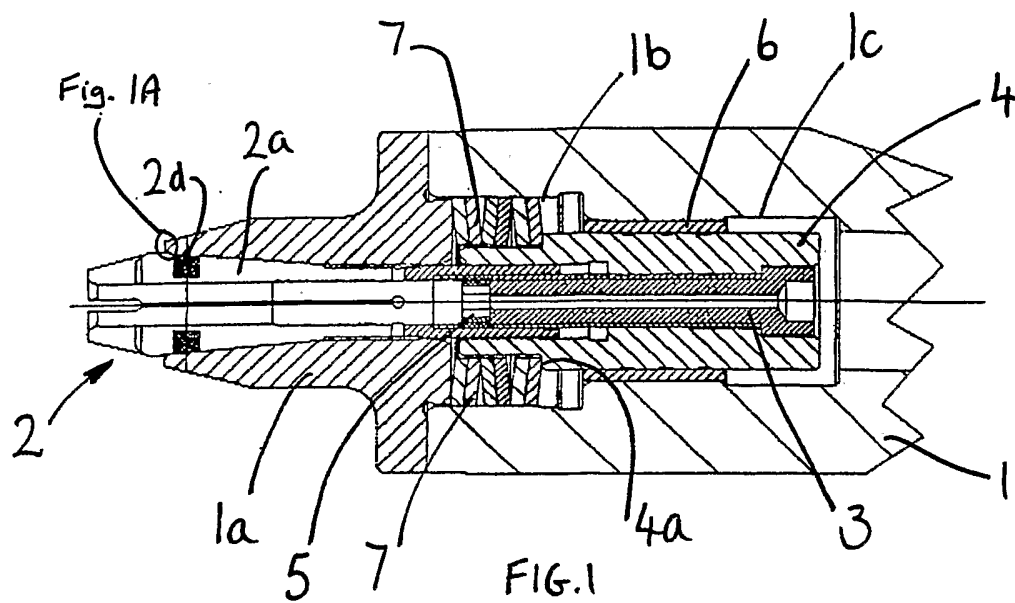

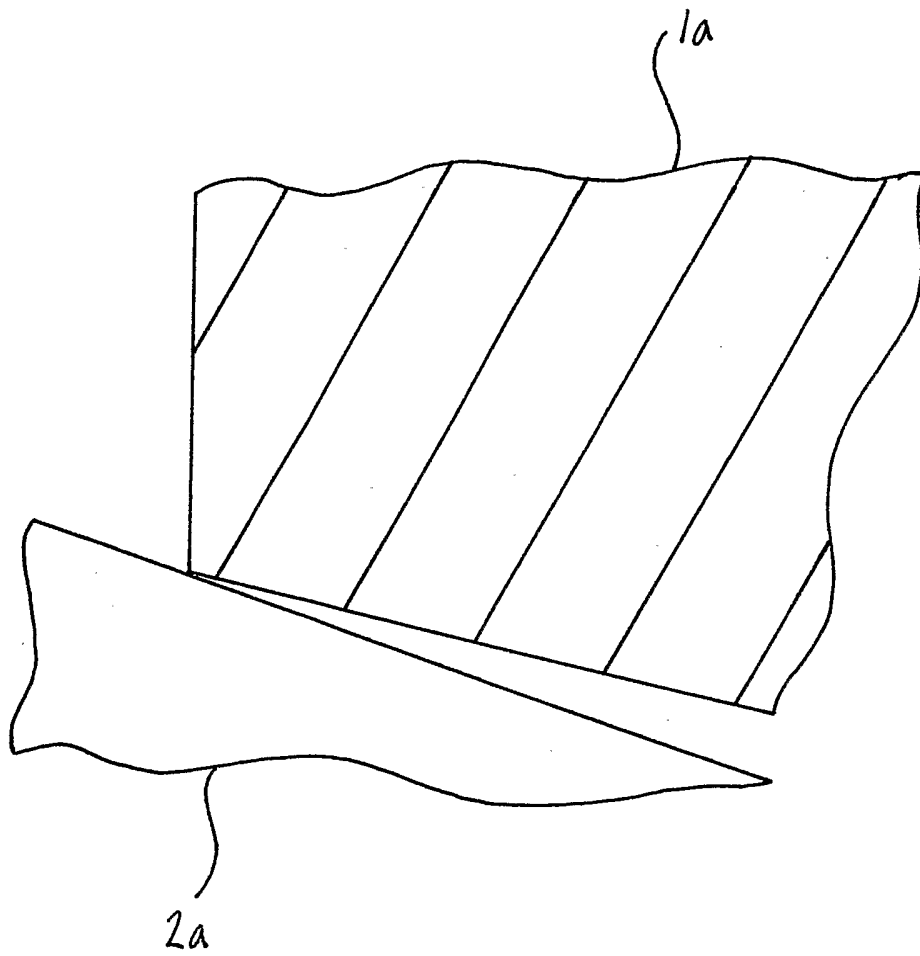

FIG. 1A