

R. ROHSOW & F. LOEWER.  
 TOOL FOR BURNISHING VELVET.  
 APPLICATION FILED FEB. 26, 1910.

998,397.

Patented July 18, 1911.

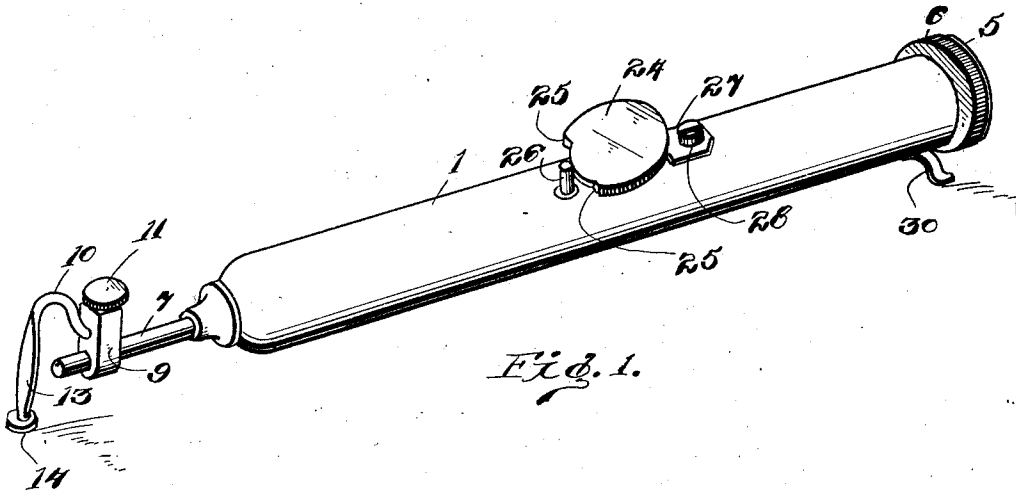

Fig. 1.

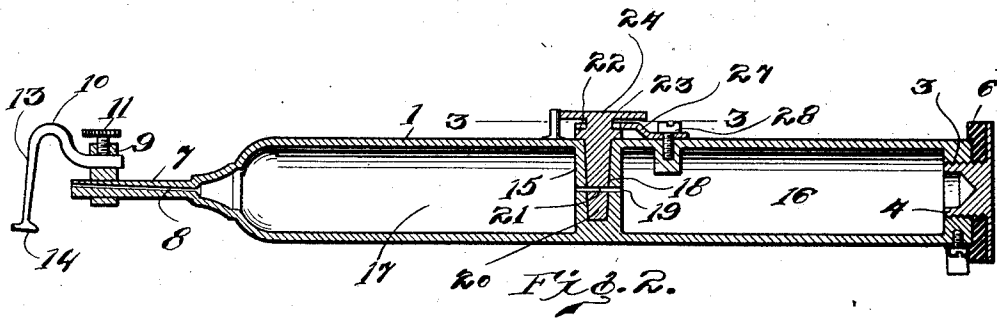
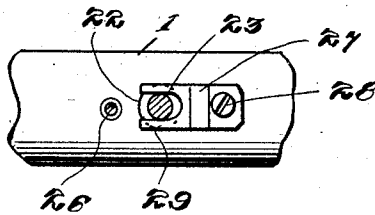

Fig. 2.

Fig. 3.



Inventors.

Robert Rohsow  
 Frederick Loewer

By *E. O. Johnson*  
 Their Attorney.

Witnesses

*John*  
*H. Jacob Doyle*

# UNITED STATES PATENT OFFICE.

ROBERT ROHSOW AND FREDERICK LOEWER, OF NEW YORK, N. Y.

TOOL FOR BURNISHING VELVET.

998,397.

Specification of Letters Patent. Patented July 18, 1911.

Application filed February 26, 1910. Serial No. 546,262.

To all whom it may concern:

Be it known that we, ROBERT ROHSOW and FREDERICK LOEWER, citizens of the United States of America, residing at New York City, in the county of New York and State of New York, have invented certain new and useful Improvements in Tools for Burnishing Velvet, of which the following is a specification, reference being had therein to the accompanying drawing.

This invention relates to burnishing tools, especially adapted, but not necessarily limited, to burnishing nappy material, such as velvet, and the principal object of the same is to provide a tool of the type specified by means of which the nap of velvet may be caused to lay smooth so that a design may be painted thereon, after which the design may be burnished to impart a luster thereto and also to make the same permanent.

In carrying out the objects of the invention generally stated above it will be understood, of course, that the essential features thereof are necessarily susceptible of changes in details and structural arrangements, one preferred and practical embodiment of which is shown in the accompanying drawings, wherein:—

Figure 1 is a perspective view of the improved burnishing tool. Fig. 2 is a central longitudinal sectional view. Fig. 3 is a sectional view taken on the line 3—3, Fig. 2.

Referring to said drawings by numerals, 1 designates the tubular body of the improved burnishing tool, one end of which is provided with a threaded opening 3 that is sealed by the threaded stem 4 of a cap 5 that is provided with a gasket lining 6 so that said cap and stem will seal the opening 3 liquid tight. At its other end, body 1 is reduced and terminates in a straight outstanding burner 7 having a longitudinal discharge outlet 8 formed through it. A lug 9 is fast on said burner, said lug having a transverse opening formed through it into which one end of a supporting arm 10 projects. The transverse opening is intersected by a threaded longitudinal opening in which a set screw 11 is mounted, said set screw detachably retaining said arm 10 in said lug. Arm 10 projects outward and upward and terminates in a flattened pendent portion 13 that is in the path of movement of the flame from burner 7, said flattened portion terminating in a burnishing plate 14.

Body 1 is centrally divided by the transverse partition 15, which provides two independent compartments 16—17. Partition 15 is integral with body 1 and is chambered as indicated at 18 and has an opening 19 formed through it that communicates with compartments 16—17. A turning plug 20 is rotatably fitted within said chamber 18, said plug being provided with an opening 21 adapted to be brought into alinement with chamber opening 19 by rotating said plug. Plug 20 projects beyond the chamber 18 and is equipped with a flange 22 that seals the open end of said chamber and with a neck 23 and a plate 24. Said plate may be manually manipulated to rotate the plug 20 and is provided with a cut away portion the opposite ends 25 of which are adapted to contact with a pin 26 projecting from body 1 to limit the turning movement of said plate. A spring 27 has one end detachably fastened to body 1 by means of a screw or like fastener 28, the free end of said spring being bifurcated as indicated at 29 and engaging neck 23 of the turning plug 20 and exerting a pressure on flange 22 to hold the same in binding engagement with body 1 over the open end of chamber 18. A supporting clip 30 is carried by the rear end of body 1 and serves as a rest to retain the tool in a position with the burnishing plate depending, as shown in Fig. 1.

The heating medium used is preferably liquid ether and the same is placed in compartment 16 through opening 3, and the body is then heated to vaporize the ether. The vapor is permitted to enter compartment 17 by turning plug 20 so that its opening registers with the opening formed through chamber 18, and passes into the restricted passage 8 of burner 7. When discharging from said burner the gas is ignited, the flame contacting with the flattened portion of arm 10 and being deflected thereby over and about plate 14, thereby heating said plate.

The tool is especially adapted for burnishing velvet that has been previously stamped or otherwise marked to form a design thereon, and in use the heated plate is used to burnish the design so that the nap of the velvet will be caused to lie flat and thereby give the design an embossed appearance. After being burnished, the design may be painted or otherwise colored, and the tool again used which will add a

gloss thereto. As will be obvious, the supporting arm 10 is detachably connected to lug 9 for the reason that other types of burnishing plates than that shown may be required, it being understood that the tool will be sold with a variety of plates, all being equipped with supporting arms that may be attached to lug 9.

What we claim as our invention is:—

10 A burnishing tool comprising a hollow cylindrical body, said body provided with an integral transverse partition which divides the same into two independent compartments, said partition provided with a

chamber and also a transverse opening that communicates with said compartments, a valve in said chamber of the partition, a burner carried by the outer end of one compartment, and a sealing cap for the outer end of the other compartment. 15 20

In testimony whereof we hereunto affix our signatures in presence of two witnesses.

ROBERT ROHSOW.  
FREDERICK LOEWER.

Witnesses:

GEORGE A. SEYMOUR, JR.,  
GEO. H. WILSON.

Copies of this patent may be obtained for five cents each, by addressing the "Commissioner of Patents, Washington, D. C."