

(19) World Intellectual Property
Organization
International Bureau



(43) International Publication Date
5 February 2004 (05.02.2004)

PCT

(10) International Publication Number
WO 2004/010923 A2

- (51) International Patent Classification⁷: **A61K** (74) Agents: **SANFORD T. COLB & CO.** et al.; P.O. Box 2273, 76122 Rehovot (IL).
- (21) International Application Number: PCT/IL2003/000631 (81) Designated States (*national*): AE, AG, AL, AM, AT, AU, AZ, BA, BB, BG, BR, BY, BZ, CA, CH, CN, CO, CR, CU, CZ, DE, DK, DM, DZ, EC, EE, ES, FI, GB, GD, GE, GH, GM, HR, HU, ID, IL, IN, IS, JP, KE, KG, KP, KR, KZ, LC, LK, LR, LS, LT, LU, LV, MA, MD, MG, MK, MN, MW, MX, MZ, NI, NO, NZ, OM, PG, PH, PL, PT, RO, RU, SC, SD, SE, SG, SK, SL, SY, TJ, TM, TN, TR, TT, TZ, UA, UG, US, UZ, VC, VN, YU, ZA, ZM, ZW.
- (22) International Filing Date: 31 July 2003 (31.07.2003) (84) Designated States (*regional*): ARIPO patent (GH, GM, KE, LS, MW, MZ, SD, SL, SZ, TZ, UG, ZM, ZW), Eurasian patent (AM, AZ, BY, KG, KZ, MD, RU, TJ, TM), European patent (AT, BE, BG, CH, CY, CZ, DE, DK, EE, ES, FI, FR, GB, GR, HU, IE, IT, LU, MC, NL, PT, RO, SE, SI, SK, TR), OAPI patent (BF, BJ, CF, CG, CI, CM, GA, GN, GQ, GW, ML, MR, NE, SN, TD, TG).
- (25) Filing Language: English
- (26) Publication Language: English
- (30) Priority Data: 60/400,167 31 July 2002 (31.07.2002) US
- (63) Related by continuation (CON) or continuation-in-part (CIP) to earlier application: US Not furnished (CIP)
Filed on 8 November 2002 (08.11.2002)
- (71) Applicant (*for all designated States except US*): **BRAINS-GATE LTD.** [IL/IL]; P.O. Box 2249, 43654 Ra'anana (IL).
- (71) Applicants and
- (72) Inventors: **GROSS, Yossi** [IL/IL]; 10 Ha'Notea Street, 73160 Moshav Mazor (IL). **SHALITA, Benny** [IL/IL]; 44 Ramat-Hagolan Street, 97704 Jerusalem (IL). **SHALEV, Alon** [IL/IL]; 9 Wingate Street, 43729 Raanana (IL).
- Published:
— *without international search report and to be republished upon receipt of that report*

[Continued on next page]

(54) Title: DELIVERING COMPOUNDS TO THE BRAIN BY MODIFYING PROPERTIES OF THE BBB AND CEREBRAL CIRCULATION

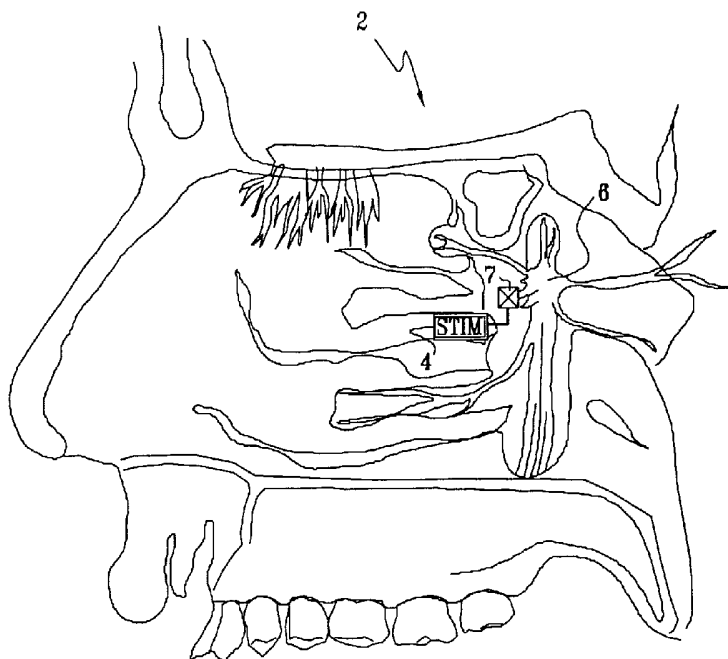

(57) Abstract: A chemical agent delivery system is provided, including a chemical agent supplied to a body of a subject for delivery to a site in a central nervous system of said subject via blood of said subject; and a stimulator (4) for stimulating parasympathetic fibers associated with the sphenopalatine ganglion (6), thereby to render a blood brain barrier (BBB) of said subject permeable to said chemical agent during at least a portion of the time that said chemical agent is present in said blood.

WO 2004/010923 A2



For two-letter codes and other abbreviations, refer to the "Guidance Notes on Codes and Abbreviations" appearing at the beginning of each regular issue of the PCT Gazette.

DELIVERING COMPOUNDS TO THE BRAIN BY MODIFYING PROPERTIES OF
THE BBB AND CEREBRAL CIRCULATION

CROSS-REFERENCES TO RELATED APPLICATIONS

5 The present patent application claims priority from US Provisional Patent Application 60/400,167, filed July 31, 2002, entitled, "Delivering compounds to the brain by modifying properties of the BBB and cerebral circulation," which is assigned to the assignee of the present patent application and is incorporated herein by reference.

10 The present patent application is a continuation-in-part of a US regular patent application to Shalev and Gross, entitled, "Method and apparatus for stimulating the sphenopalatine ganglion to modify properties of the BBB and cerebral blood flow," filed November 8, 2002, which is a national phase patent application of PCT/IL01/00402 filed May 7, 2001, which, in turn, claims priority from US Provisional Patent Application 60/203,172 filed May 8, 2000. Each of these applications is assigned to the assignee of the present patent application and is incorporated herein by reference.

15 **FIELD OF THE INVENTION**

The present invention relates generally to medical procedures and electronic devices. More specifically, the invention relates to the use of electrical devices for implantation in the head, for example, in the nasal cavity. The invention also relates to methods for using odorants for medical purposes. The invention also relates to apparatus and methods for administering drugs, for treating medical conditions, and for improving cerebral blood flow.

BACKGROUND OF THE INVENTION

25 The blood-brain barrier (BBB) is a unique feature of the central nervous system (CNS) which isolates the brain from the systemic blood circulation. To maintain the homeostasis of the CNS, the BBB prevents access to the brain of many substances circulating in the blood.

The BBB is formed by a complex cellular system of endothelial cells, astroglia, pericytes, perivascular macrophages, and a basal lamina. Compared to other tissues, brain endothelia have the most intimate cell-to-cell connections: endothelial cells adhere

strongly to each other, forming structures specific to the CNS called "tight junctions" or zonula occludens. They involve two opposing plasma membranes which form a membrane fusion with cytoplasmic densities on either side. These tight junctions prevent cell migration or cell movement between endothelial cells. A continuous uniform basement membrane surrounds the brain capillaries. This basal lamina encloses contractile cells called pericytes, which form an intermittent layer and probably play some role in phagocytosis activity and defense if the BBB is breached. Astrocytic end feet, which cover the brain capillaries, build a continuous sleeve and maintain the integrity of the BBB by the synthesis and secretion of soluble growth factors (e.g., gamma-glutamyl transpeptidase) essential for the endothelial cells to develop their BBB characteristics.

Because of the BBB, certain non-surgical treatments of the brain based upon systemic introduction of compounds through the bloodstream have been ineffective or less effective. For example, chemotherapy has been relatively ineffective in the treatment of CNS metastases of systemic cancers (e.g., breast cancer, small cell lung cancer, lymphoma, and germ cell tumors), despite clinical regression and even complete remission of these tumors in non-CNS systemic locations. The most important factors determining drug delivery from blood into the CNS are lipid solubility, molecular mass, and electrical charge. A good correlation exists between the lipid solubility of a drug, expressed as the octanol/water partition coefficient, and the drug's ability to penetrate or diffuse across the BBB. This is particularly relevant for drugs with molecular weights smaller than 600 dalton (Da). The normal BBB prevents the passage of ionized water soluble drugs with a molecular weight greater than 180 Da. Most currently-available effective chemotherapeutic agents, however, have a molecular weight between 200 and 1200 Da. Therefore, based both on their lipid solubilities and molecular masses, the passage of many agents is impeded by the BBB.

In addition to transcellular diffusion of lipophilic agents, there are several specific transport mechanisms to carry certain molecules across the brain's endothelial cells. Specific transport proteins exist for required molecules, such as glucose and amino acids. Additionally, absorptive endocytosis and transcytosis occur for cationized plasma proteins. Specific receptors for certain proteins, such as transferrin and insulin, mediate endocytosis and transport across the cell.

Non-surgical treatment of neurological disorders is generally limited to systemic introduction of compounds such as neuropharmaceuticals and other neurologically-active agents that might remedy or modify neurologically-related activities and disorders. Such treatment is limited, however, by the relatively small number of known
5 compounds that pass through the BBB. Even those that do cross the BBB often produce adverse reactions in other parts of the body or in non-targeted regions of the brain.

There have been a number of different studies regarding efforts to cross the BBB -- specifically, with regard to overcoming the limited access of drugs to the brain. Such efforts have included, for example, chemical modification, development of more
10 hydrophobic analogs, or linking an active compound to a specific carrier. Transient opening of the BBB in humans has been achieved by intracarotid infusion of hypertonic mannitol solutions or bradykinin analogs. Also, modulation of the P-glycoprotein, whose substrates are actively pumped out of brain cells into capillary lumens, has been found to facilitate the delivery of drugs to the brain. However, due to the inherent limitations of
15 each of the aforementioned procedures, there is still a need for more generic, effective, and predictable ways to cross the BBB.

It would also be desirable to develop controllable means for modulating cerebral blood flow. Many pathological conditions, such as stroke, migraine, and Alzheimer's disease, are significantly affected or exacerbated by abnormal cerebral blood flow.

20 US Patent 5,756,071 to Mattern et al., which is incorporated herein by reference, describes a method for nasally administering aerosols of therapeutic agents to enhance penetration of the blood brain barrier. The patent describes a metering spray designed for pernasal application, the spray containing at least one sex hormone or at least one metabolic precursor of a sex hormone or at least one derivative of a sex hormone or
25 combinations of these, excepting the precursors of testosterone, or at least one biogenic amine, with the exception of catecholamines.

US Patent 5,752,515 to Jolesz et al., which is incorporated herein by reference, describes apparatus for image-guided ultrasound delivery of compounds through the blood-brain barrier. Ultrasound is applied to a site in the brain to effect in the tissues
30 and/or fluids at that location a change detectable by imaging. At least a portion of the brain in the vicinity of the selected location is imaged, e.g., via magnetic resonance imaging, to confirm the location of that change. A compound, e.g., a

neuropharmaceutical, in the patient's bloodstream is delivered to the confirmed location by applying ultrasound to effect opening of the blood-brain barrier at that location and, thereby, to induce uptake of the compound there.

5 The following references, which are incorporated herein by reference, may be useful:

Delepine L, Aubineau P, "Plasma protein extravasation induced in the rat dura mater by stimulation of the parasympathetic sphenopalatine ganglion," *Experimental Neurology*, 147, 389-400 (1997)

10 Hara H, Zhang QJ, Kuroyanagi T, Kobayashi S, "Parasympathetic cerebrovascular innervation: An anterograde tracing from the sphenopalatine ganglion in the rat," *Neurosurgery*, 32, 822-827 (1993)

Jolliet-Riant P, Tillement JP, "Drug transfer across the blood-brain barrier and improvement of brain delivery," *Fundam. Clin. Pharmacol.*, 13, 16-25 (1999)

15 Kroll RA, Neuwelt EA, "Outwitting the blood brain barrier for therapeutic purposes: Osmotic opening and other means," *Neurosurgery*, 42, 1083-1100 (1998)

Sanders M, Zuurmond WW, "Efficacy of sphenopalatine ganglion blockade in 66 patients suffering from cluster headache: A 12-70 month follow-up evaluation," *Journal of Neurosurgery*, 87, 876-880 (1997)

20 Syelaz J, Hara H, Pinard E, Mraovitch S, MacKenzie ET, Edvinsson L, "Effects of stimulation of the sphenopalatine ganglion on cortical blood flow in the rat," *Journal of Cerebral Blood Flow and Metabolism*, 8, 875-878 (1988)

Van de Waterbeemd H, Camenisch G, Folkers G, Chretien JR, Raevsky OA, "Estimation of blood brain barrier crossing of drugs using molecular size and shape and h bonding descriptors," *Journal of Drug Targeting*, 6, 151-165, (1998)

25 Suzuki N, Hardebo JE, Kahrstrom J, Owman C, "Selective electrical stimulation of postganglionic cerebrovascular parasympathetic nerve fibers originating from the sphenopalatine ganglion enhances cortical blood flow in the rat," *Journal of Cerebral Blood Flow and Metabolism*, 10, 383-391 (1990)

Suzuki N, Hardebo JE, Kahrstrom J, Owman CH, "Effect on cortical blood flow of electrical stimulation of trigeminal cerebrovascular nerve fibres in the rat," *Acta Physiol. Scand.*, 138, 307-315 (1990)

Major A, Silver W, "Odorants presented to the rat nasal cavity increase cortical blood flow," *Chem. Senses*, 24, 665-669 (1999)

Fusco BM, Fiore G, Gallo F, Martelletti P, Giacobuzzo M, "Capsaicin-sensitive sensory neurons in cluster headache: pathophysiological aspects and therapeutic indications," *Headache*, 34, 132-137 (1994)

Lambert GA, Bogduk N, Goadsby PJ, Duckworth JW, Lance JW, "Decreased carotid arterial resistance in cats in response to trigeminal stimulation," *Journal of Neurosurgery*, 61, 307-315 (1984)

Silver WL, "Neural and pharmacological basis for nasal irritation," in Tucker WG, Leaderer BP, Mølhav L, Cain WS (eds), *Sources of Indoor Air Contaminants*, Ann. NY Acad. Sci., 641, 152-163 (1992)

Silver W, "Chemesthesis: the burning questions," *ChemoSense*, Vol. 2, 1-2 (1999)

SUMMARY OF THE INVENTION

It is an object of some aspects of the present invention to provide improved methods and apparatus for delivery of compounds to the brain, particularly through the BBB.

It is also an object of some aspects of the present invention to provide such methods and apparatus as can be employed to deliver such compounds through the BBB with a minimally invasive approach.

It is a further object of some aspects of the present invention to provide such methods and apparatus as can facilitate delivery of large molecular weight compounds through the BBB.

It is yet a further object of some aspects of the present invention to provide cost-effective methods and apparatus for delivery of compounds through the blood-brain-barrier.

It is still a further object of some aspects of the present invention to provide improved methods and apparatus for remedying or modifying neurological activities and disorders via delivery of compounds through the blood-brain-barrier.

5 It is also a further object of some aspects of the present invention to modulate cerebral blood flow.

It is an additional object of some aspects of the present invention to provide improved methods and apparatus for treating stroke.

10 It is yet an additional object of some aspects of the present invention to provide improved methods and apparatus for treating migraine, cluster and other types of headaches.

It is still an additional object of some aspects of the present invention to provide improved methods and apparatus for treating neurological diseases (for example, Alzheimer's disease), whose prognosis and evolution of pathological symptoms are influenced by cerebral blood flow.

15 It is also an object of some aspects of the present invention to provide implantable apparatus which affects a property of the brain, without actually being implanted in the brain.

It is a further object of some aspects of the present invention to provide methods which affect a property of the brain without the use of implantable apparatus.

20 It is yet a further object of some aspects of the present invention to affect a property of the brain by using the neuroexcitatory and/or neuroinhibitory effects of odorants on nerves in the head.

These and other objects of the invention will become more apparent from the description of preferred embodiments thereof provided hereinbelow.

25 In preferred embodiments of the present invention, an electrical stimulator drives current into the sphenopalatine ganglion (SPG) or into neuroanatomical structures, including neural tracts originating or reaching the SPG, including outgoing and incoming parasympathetic and sympathetic tracts and other parasympathetic centers. Typically, the stimulator drives the current in order to control and/or modify SPG-
30 related behavior, e.g., in order to induce changes in cerebral blood flow and/or to

modulate permeability of the blood-brain barrier (BBB). These embodiments may be used in many medical applications, such as, by way of illustration and not limitation, (a) the treatment of cerebrovascular disorders such as stroke, (b) the treatment of migraine, cluster and other types of headaches, or (c) the facilitation of drug transport across the
5 BBB.

It is to be understood that "SPG modulation" as used in the context of the present patent application and in the claims includes stimulation or inhibition of the SPG and its related neuroanatomical structures, including neural tracts originating or reaching the SPG, these tracts including outgoing and incoming parasympathetic and sympathetic
10 tracts.

It is to be appreciated that, whereas preferred embodiments of the present invention are described with respect to driving current into the SPG or into neural structures directly related thereto, the scope of the present invention includes driving current into other sites in the brain which, in response to this modulation, modulate
15 cerebral blood flow or modulate permeability properties of the BBB, as appropriate for a given application.

It is further to be appreciated that implantation and modulation sites, methods of implantation, and parameters of modulation are described herein by way of illustration and not limitation, and that the scope of the present invention includes other possibilities
20 which would be obvious to someone of ordinary skill in the art who has read the present patent application.

It is yet further to be appreciated that while preferred embodiments of the invention are generally described herein with respect to electrical transmission of power and electrical modulation of tissue, other modes of energy transport may be used as well.
25 Such energy includes, but is not limited to, direct or induced electromagnetic energy, radiofrequency (RF) transmission, ultrasonic transmission, optical power, and low power laser energy (via, for example, a fiber optic cable).

It is additionally to be appreciated that whereas preferred embodiments of the present invention are described with respect to application of electrical currents to tissue,
30 this is to be understood in the context of the present patent application and in the claims

as being substantially equivalent to applying an electrical field, e.g., by creating a voltage drop between two electrodes.

The SPG is a neuronal center located in the brain behind the nose. It consists of parasympathetic neurons innervating the middle cerebral and anterior cerebral lumens, the facial skin blood vessels, and the lacrimal glands. Activation of this ganglion is believed to cause vasodilation of these vessels. A second effect of such stimulation is the opening of pores in the vessel walls, causing plasma protein extravasation (PPE). This effect allows better transport of molecules from within these blood vessels to surrounding tissue.

The middle and anterior cerebral arteries provide the majority of the blood supply to the cerebral hemispheres, including the frontal and parietal lobes in their entirety, the insula and the limbic system, and significant portions of the following structures: the temporal lobes, internal capsule, basal ganglia and thalamus. These structures are involved in many of the neurological and psychiatric diseases of the brain, and preferred embodiments of the present invention are directed towards providing improved blood supply and drug delivery to these structures.

There is also animal evidence for the presence of SPG-originated parasympathetic innervation in the posterior cerebral and basilar arteries. Consistent with the assumption that this is also the case in humans, many regions of the human brain are within the reach of treatments provided by preferred embodiments of the present invention, as described hereinbelow.

Currently the SPG is a target of manipulation in clinical medicine, mostly in attempted treatments of severe headaches such as cluster headaches. The ganglion is blocked either on a short-term basis, by applying lidocaine, or permanently, by ablation with a radio frequency probe. In both cases the approach is through the nostrils. In some preferred embodiments of the present invention, similar methods for approaching the SPG are utilized, to enable the electrical stimulation or electrical blocking thereof.

According to a preferred embodiment of the instant invention, a method and apparatus are provided to enhance delivery of therapeutic molecules across the BBB by modulation of the SPG and/or its outgoing parasympathetic tracts and/or another parasympathetic center. The apparatus typically stimulates the parasympathetic nerve

fibers of the SPG, thereby inducing the middle and anterior cerebral arteries to dilate, and also causing the walls of these cerebral arteries to become more permeable to large molecules. In this manner, the movement of large pharmaceutical molecules from within blood vessels to the cerebral tissue is substantially increased. Preferably, therefore, this method can serve as a neurological drug delivery facilitator, without the sacrifices in molecular weight required by techniques of the prior art. In general, it is believed that substantially all pharmacological treatments aimed at cerebral cells for neurological and psychiatric disorders are amenable for use with these embodiments of the present invention. In particular, these embodiments may be adapted for use in the treatment of disorders such as brain tumors, epilepsy, Parkinson's disease, Alzheimer's disease, multiple sclerosis, schizophrenia, depression, stress, anxiety, and any other CNS disorders that are directly or indirectly affected by changes in cerebral blood flow or by BBB permeability changes.

Advantageously (and even in the absence of BBB permeability changes), patients with these and other disorders are generally helped by the vasodilation secondary to stimulation of the SPG, and the resultant improvement in oxygen supply to neurons and other tissue. For some applications, this treatment is given on a long-term basis, e.g., in the chronic treatment of Alzheimer's patients. For other applications, the treatment is performed on a short-term basis, e.g., to minimize the damage following an acute stroke event and initiate neuronal and therefore functional rehabilitation.

Blocking of nerve transmission in the SPG or in related neural tracts is used in accordance with some preferred embodiments of the present invention to treat or prevent migraine headaches.

Alternatively or additionally, the changes induced by electrical modulation as described hereinabove are achieved by presenting odorants to an air passage of a patient, such as a nasal cavity or the throat. There is animal evidence that some odorants, such as propionic acid, cyclohexanone, and amyl acetate, significantly increase cortical blood flow when presented to the nasal cavity. This has been interpreted by some researchers as evidence that these odorants (e.g., environmental pollutants) may be involved in the formation of various headaches by increasing cerebral blood flow. The temporal profile and other quantitative characteristics of such odorant modulation are believed by the present inventors to have a mechanism of action that has a neuroanatomical basis

overlapping with that of the electrical modulation of the SPG. Furthermore, experimental animal evidence collected by the inventors and described in a US provisional patent application to Shalev and Gross entitled, "SPG stimulation," filed March 28, 2002, which is assigned to the assignee of the present invention and is incorporated herein by reference, suggest a correlation between the mechanisms of increasing cerebral blood flow and increased cerebrovascular permeability. It is hypothesized that such increased cerebral blood flow caused by odorants is a result of stimulation of parasympathetic and/or trigeminal fibers. These fibers may mediate cerebral blood flow changes directly, by communicating with the SPG, or by some other mechanism. It is also hypothesized that these odorants stimulate via reflex arcs the SPG or other autonomic neural structures that innervate the cerebrovascular system. Therefore, the inventors hypothesize, odorant "stimulation" may increase cerebral blood flow in general, and cortical blood flow in particular, by some or all of the same mechanisms as electrical stimulation, as described hereinabove. Alternatively or additionally, odorants may cause increased cortical blood flow by other mechanisms, such as by entering the blood stream and reaching the affected blood vessels in the brain or by parasympathetic stimulation via the olfactory nerve. In addition to the effect on cerebral blood flow, the introduction of odorants into an air passage is also believed by the inventors to induce an increase in the permeability of the anterior two thirds of the cerebrovascular system to circulating agents of various sizes, i.e. to increase the permeability of the BBB. Similarly, presenting certain other odorants to an air passage decreases cerebral blood flow and decreases the permeability of the BBB.

Odorants that may increase or decrease cerebral blood flow and/or the permeability of the BBB include, but are not limited to, propionic acid, cyclohexanone, amyl acetate, acetic acid, citric acid, carbon dioxide, sodium chloride, ammonia, menthol, alcohol, nicotine, piperine, gingerol, zingerone, allyl isothiocyanate, cinnamaldehyde, cuminaldehyde, 2-propenyl/2-phenylethyl isothiocyanate, thymol, and eucalyptol.

According to a preferred embodiment of the instant invention, a method is provided to enhance delivery of therapeutic molecules across the BBB by presenting an odorant to an air passage of a patient, such as a nasal cavity or the throat. In a preferred application, this method serves as a neurological drug delivery facilitator. The odorant

is preferably presented using apparatus known in the art, such as aqueous spray nasal inhalers; metered dose nasal inhalers; or air-dilution olfactometers. Alternatively or additionally, the odorant is presented by means of an orally-dissolvable capsule that releases the active odorants upon contact with salivary liquids. The odorants reach the appropriate neural structures and induce vasodilatation, vasoconstriction and/or cerebrovascular permeability changes. Delivery of a drug can be achieved by mixing the drug with the odorant; by intravenously, intraperitoneally, or intramuscularly administering the drug, or by other delivery methods known in the art. For some applications, it is desirable to combine a local analgesic with the odorant in order to diminish any possible sensation of pain or discomfort that may directly or indirectly (e.g., via a reflex arc) accompany the odorant action upon nerves in the head. For example, preventing neural transmission in the neighboring pain fibers may be performed as a "pre-odorant" treatment, by topical administration of capsaicin together with a local analgesic for several days prior to the use of odorant stimulation. In this manner, the odorants typically induce the SPG-related response with a reduced or eliminated sensation of pain or discomfort.

In general, it is believed that substantially all pharmacological treatments aimed at cerebral cells for neurological and psychiatric disorders are amenable for use with these embodiments of the present invention. In particular, this embodiment may be adapted for use in the treatment of disorders such as brain tumors, epilepsy, Parkinson's disease, Alzheimer's disease, multiple sclerosis, schizophrenia, depression, stress, anxiety, disorders requiring the administration of various growth factors, and other CNS disorders that are directly or indirectly affected by changes in cerebral blood flow or by BBB permeability changes.

Alternatively or additionally, a method is provided for increasing or reducing cortical blood flow and/or inducing or inhibiting vasodilation (even in the absence of BBB permeability changes) by presenting an odorant to an air passage of a patient, such as a nasal cavity or the throat, for treatment of a condition. Patients with the aforementioned disorders and other disorders are generally helped by vasodilation and the resultant improvement in oxygen supply to neurons and other tissue. For some applications, this treatment is given on a long-term basis, e.g., in the chronic treatment of Alzheimer's patients. For other applications, the treatment is performed on a short-term

basis, e.g., to minimize the damage following an acute stroke event and initiate neuronal and therefore functional rehabilitation. Alternatively or additionally, the method provided above can be used for diagnostic purposes or in conjunction with other diagnostic methods and/or apparatus known in the art, in order to enhance diagnostic results, reduce procedure risk, reduce procedure time, or otherwise improve such diagnostic procedures and/or diagnostic results. For example, methods and apparatus described herein may be used to increase the uptake into the brain of a radio-opaque material, in order to facilitate a CT scan.

Decreasing cerebral blood flow by presenting certain odorants to an air passage is used in accordance with some preferred embodiments of the present invention to treat or prevent various types of headaches, especially with an autonomic nervous system (ANS) etiology, such as migraine and cluster headaches.

As described above, it is believed that substantially all pharmacological treatments aimed at cerebral cells (for example those used for treating neurological and psychiatric disorders and pathologies) are amenable for use in combination with techniques described herein, including electrical SPG modulation and odorant presentation techniques. In particular, these embodiments of the present invention may be adapted for use in facilitating the administration of the following pharmacological agents. Although the list is organized by indication, it is to be understood that each pharmacological agent may be administered for additional indications other than those indicated herein.

Anxiolytic Medications

INDICATION	MEDICATIONS
Anxiety and tension	Abecrmil, Adinazolam, Alpidem, Alprazolam, Bentazepam, Bromazepam, Buspiron, Camazepam, Capipramine, Captodiame, Chlordiazepoxide, Chlormezanone, Chlorpromazine, Cinolazepam, Citalopram, Clobazam, Clorazepam, Clothiaprim, Clotiazepam, Cloxazolam, Cyanemazine, Cyclobarbiton, Delorazepam, Dexmedetomidone, Diazepam, Dichloralphenazone, Difenbarbamate, Dipotassium, Ethyl-Loflazepate, Etifoxin, Etizolam, Febarbamate, Fludiazepam, Fluphenazine, Halazepam, Haloperidol, Hydroxyzine, Ipsapirone, Ketazolam, Levomepromazine, Lorazepam, Medazepam, Mephenoxalone, Meproamat, Mesoridazine, Metaclazepame, Mexazolam, Nefazodone, Nordazepam, Oxazepam, Oxazolam, Oxypertine, Paroxetine, Pericyazine, Perphenazine, Phenobarbitone, Phenprobamate, Pinazepam, Prazepam, Prochlorperazine, Proxibarbal, Risperidone, Ritansertin, Sertraline, Sulpirid, Suriclone, Tandospirone, Thioridazine, Tofisopam, Trifluoperazine, Valnodamide
Anxiety and depression	Alprazolam, Opipramol, Oxazepam
Anxiety nervousness	Perphenazine
Panic related disorder	Alprazolam
Paranoia	Pimozid
Hypochondria	Pimozid

Anticonvulsant Medications

INDICATION	MEDICATIONS
Epilepsy	Amylobarbitone, Carbamezapin, Chlormethiazole,

	Cinolazepam, Clobazepam, Clonazepam, Clorazepic acid, Diazepam, Dxcarbazepine, Ethosuximide, Felbamate, Fluoxetine, Fosphenytoin, Gabapentin, Hydantoin, Lamotrigine, Lamotrigine, Lorazepam, Methonin, Methsuximide, Midazolam, Nitrazepam, Oxcarbazepine, Paraldehyde, Paramethadione, Phenacemide, Pheneturide, Phenobarbitone, Phensuximide, Phenytoin, Progabide, Propericiazine, Pyrimidindione, Sodium Valproate, Stiripental, Sulthiame, Sulthiame, Tiagabine, Tiagabine, Topiramate, Troxidone, Pivoxil, Valproic Acid, Valpromide, Vigabatrine, Vigalatin
Convulsions	Benzodiazepine, Diazepam, Ethchlovynol
Febrile Convulsion	Phenobarbitone

Antipsychotic Medications

INDICATION	MEDICATIONS
Schizophrenia	Bromperidol, Chlorpromazine, Citalopram, Clozapamine, Clothiazepin, Clozapine, Diazepam, Dibenzodiazepine, Flupenthixol, Fluphenazine, Fluspirilene, Haloperidol, Levomepromazine, Lithium Carbonate, Loxapine, Melperone, Methotrimeprazine, Mezoridazine, Molindone, Nemonapride, Olanzapine, Olanzapine, Oxipertine, Penfluridol, Pericyazine, Perphenazine, Pipothiazine, Prochlorperazine, Quetiapine, Remoxipride, Risperidone, Ritanserin, Secbutobarbitone, Sulpirid, Sultopride, Thioproperazine, Thioridazine, Thiothixene, Thioxanthen, Timiperone, Trifluoperazine, Trifluoperidol, Ziprasidone, Zotepine, Zuclopenthixol
Agitation, restless and disturbed behavior	Buspiron, Chlormethiazole, Chlorpromazine, Clozapine, Cyanemazine, Droperidol, Eltoprazine, Fluamisone, Fluoxetine, Fluphenazine, Haloperidol, Lorazepam, Loxapine, Medazepam, Melperone, Mesoridazine, Methotrimeprazine, Oxypertine, Pericyazine, Perphenazine, Promazine, Propericiazine, Prothipendyl, Sultopride, Thioridazine, Tiapride, Tranlycypramine, Trifluoperazine, Zuclopenthixol

Alcohol withdrawal syndrome	Abecarnil, Chlormethiazole, Chlorpromazine
Psychosis and psychotic disorder	Acetophenazine, Amisulpride, Benperidol, Bromoperidol, Carbamezapine, Chlorpromazine, Chlorprothiexn, Clonazepam, Clothiapin, Flupenthixol, Flupromazine, Fluspirilene, Haloperidol, Homofenazine, Levomepromazine, Molindone, Mosapramine, Oxypertine, Penfluridil, Perazine, Pericyazine, Perphenazine, Pimozid, Pipameperone, Pipothiazine, Prochlorperazine, Prothipendyl, Remoxipride, Risperidone, Suspired, Thioproperazine, Thioridazine, Thiothixene, Thioxanthen, Trifluperazine, Trifluperidol
Mania	Carbamezapine, Chlorpromazine, Clotiapine, Droperidol, Fluphenazine, Haloperidol, Oxipertine, Perphenazine, Prochlorperazine, Thioproperazine, Thioridazine, Zuclopenthixol
Pathological crying or laughing	Citalopram, Fluoxetine
Obsessive compulsive disorder	Fluoxetine
Anorexia nervosa	Amitriptyline, Fluoxetine
Bulimia nervosa	Amitriptyline, Fluoxetine, Haloperidol, Tetrabenazine
Tourette's Syndrome	Buspiron, Fluphenazine, Haloperidol, Pimozid, Riperidone, Sulpirid
Tics, hiccups	Amitriptyline, Carbamezapine, Chlorpromazine, Clonazepam, Haloperidol, Midazolam, Perphenazine, Promazine
Confusion syndrome	Levomepromazine
Panic disorder	Cytalopram, Paroxetine
Hyperactivity	Amitriptyline, Carbamezapine, Desimipramin, Fluoxetine, Imipramine, Phenelazine
Mania associated with bipolar I disorder	Phenothiazine

Mental and emotional disturbances	Phenothiazine
Character disorder	Proprietaryazine
Obsession neurosis	Proprietaryazine
Neurosis with psychomotor inhibition	Sulpirid
Psychological symptoms associated with menopause	Veralipride

Medications for Neurodegenerative Diseases

INDICATION	MEDICATIONS
Parkinson Disease and Parkinsonism	Amantadine, Apomorphine, Benserazide (+Carbidopa), Benztropine, Biperiden, Bromocriptine, Cabergolin, Caergoline, Carbidopa, Clozapine, Deprenyl (Selegilin), Diphenhydramine, Droxidopa, Entacapone, Fluoxetine, Gabapentine, Hyoscyamine, Lazabemide, Levodopa, Lisurid, Memantine, Naxagolide, Pergolide, Piribedil, Pramipexole, Pramipexole, Procyclidine, Quinagolide, Ropinirol, Talipexol, Terguride, Tolcapone, Risperidone, Trihexyphenidyl
Tremor	Propranolol, Tiapride
Psychomotor seizures	Phenytoin
Alzheimer's disease and dementia	Donepezil, Eptostigmine, Galantamine, Linopiridine, Physostigmine, Risperidone, Rivastigmine, Rivastigmine, Selegelin, Tacrine, Xanomeline, Zifrosilone
Multiple Sclerosis	Interferon(s) Copolymer-1

Hypnotic Medications

INDICATION	MEDICATIONS
Insomnia	Acepromazine, Aceprometazine, Acetylglycinamid, Allbarbitone, Amylobarbitone, Aprobarbital, Barbitone, Bentazepam, Benzodiazpine, Bromazepam, Brotizolam, Butobarbitone, Chloral Hydrate, Chloralbetaine, Chloralose, Chlordiazepoxide, Chlormethiazole, Cinolazepam, Clotiazepam, Cyclopyrotone, Delorazepam, Diazepam, Doxytamine, Estazolam, Ethchlorvynol, Etizolam, Etodroxizine, Febarbamate, Flunitrazepam, Flurazepam, Glutethimide, Haloxazolam, Hexapropymate, Hexobarbitone, Loprazolam, Lorazepam, Lormetazwpam, Meprobamate, Methylpentynol, Midazolam, Nitrazepam, Nordazepam, Oxazepam,

	Pentobarbitone, Phenobarbitone, Pinazepam, Pyrithidione, Quazepam, Quinalbarbitone, Temazepam, Tiazolam, Triazolam, Triclofos, Zolpidem, Zopiclone
Promotion of sleep	Benzodiazpine, Triclofos
Parasomnia	Clonazepam, Diazepam, Levodopa

Sedative Medications

INDICATION	MEDICATIONS
Sedation	Acetylglycinamid, Chloral Hydrate, Detomidin, Dexmedetomidine, Diazepam, Dixyrazine, Ethchlorvynol, Mexazolam
Nervous condition	Valerian

CNS Stimulant Medications

INDICATION	MEDICATIONS
Sympatho-mimetic	Adrenalin, Amphetamins, Pemolene
CNS Stimulant	Fluoxetine, Methylphenidate

Anti-Depressant Medications

INDICATION	MEDICATIONS
Depression	Aloprazolam, Amitriptyline, Amoxapine, Befloxantone, Benactyzine, Brofaromine, Bupropion, Butriptyline, Citalopram, Clomipramine, Citalopram, Desipramine, Dibenzepine, Dothiepine, Doxepine, Dueoxetine, Etoferidon, Femoxetine, Fluoxetine, Fluroxamine, Imipramine, Iprindole, Iproniazid, Isocarboxazide, Lofepramine, Maprotillin, Medifoxamine, Melitracen, Metapramine, Mianserin, Milanacipram, Minaprine, Mirtazapine, Moclobemide, Nefazodone, Nialamid, Nomifensine, Nortriptyline, Oxitriptan, Paroxetine, Paroxetine, Phenelzine, Protriptyline, Quinupramine, Riboxetine, Ritanserin, Rubidium, Selegilin, Sertraline, Setiptillin, Sulprid, Teniloxazine, Tianeptine, Toloxatone, Tranylcypromine, Trazodonn, Trimipramine, Vanlafaxine, Venlofaxine
Manic depression	Carbamezapine, Levomepromazine, Lithium Carbonate, Valproic Acid
Melancholy	Amitriptyline, Desipramine
Low mood	Fluroxamine
Psychosomatic complaints	Fluroxamine

Medications for treatment and prevention of migraines

INDICATION	MEDICATIONS
Treatment of migraine	Acetylsalicylic acid, Almotriptan, Buclizine, Chlorpromazine, Dihydroergotamine, Ergotamine, Lisurid, Metrgoline, Mthysergide, Naratriptan, Paracetamol, Phenelzine, Prochlorperazine, Rizatriptan, Sumatriptan, Zolmitriptan
Prevention of migraine	Clonidin, Metoprolol, Pizotifen, Propranolol
Vascular headache	Diazepam

Anti-Emetics and Anti-Nauseates Medications

INDICATION	MEDICATIONS
Nausea and vomiting	Chlorpromazine, Cinnarizine, Diazepam, Dixyrazine, Flupromazine, Haloperidol (in migraine), Prochlorperazine, Trifluoperazine
Nausea and vomiting induced by neoplastic therapy or post operation	Granisetron, Lorazepam, Ondansetron, Perphenazine, Tropisetron,

Medications for Neurological Diseases

INDICATION	MEDICATIONS
Cerebral malaria	Phenobarbital
Motor-neuron disease	Gabapentin
Cerebro-vascular disorder	Amilobarbitone, Pentobarbitone
Extrapyramidal disorder	Buspirin, Diazepam, Levodopa, Terabenazine, Tiapride
Cerebral ataxis	Buspirin, Physostigmine
Stroke	Chlomethiazole
Neuroleptic syndrome	Amitriptyline, Clomipramine
Trigeminal neuralgia	Carbamezapine, Clonazepam
Autism	Imipramine
Movement disorder	Carbamezapine
Resting legs syndrome	Carbamezapine
Phantom limb pain	Clonazepam
Stiffness syndrome	Clonazepam
Chorea	Chlorpromazine, Fluphenazine, Haloperidol, Levodopa, Pimozid, Sulpiride, Terabenazine, Tiapride

Diskinesias	Tiaprider
Brain injury (comatose state)	Memantine
Central spasticity	Memantine
Vertigo	Betahistine, Diazepam, Prochlorperazine, Sulpiride
Dystonia	Chlorpromazine, Pimozid, Risperidone, Terabenazine
Movement disorder	Tetrabenazine
Lesch-Nyhan syndrome	Chlorpromazine
Menieres Disease	Prochlorperazine

Dopaminergic Agents

INDICATION	MEDICATIONS
Hyperprolact-emia and prolactnoma	Bromocryptine, Caergoline, Lisuride, Metergoline, Pergolide, Pramipexole, Quinagoline, Ropinirol, Terguride
Acromegaly	Pergolide, Quinagolide

Anti-Neoplastic Agents

INDICATION	MEDICATIONS
Brain tumors or metastases	5-floururacil, BCNU, Broxuridine (+ radiotherapy), Carmustine, Cisplatin, Cyclophosphamide, Dactinomycine, Doxorubicin, Ethoposide, Fotemustine, Lomustine, Lonidamine, Methotrexate, Mitolactol, Mustine, Procarbazine, Semustine, Teniposide, Vincristine
	OTHER MEDICATIONS
	Carboplatin, Diaziquone, Melphalan, Mitolactol, Paclitaxel, Temozolomide, Thalidomide, Tomozolomide, Tymidine Kinas of Herpes Simples Virus
	REPORTS
	BCNU + Radiotherapy, Buserelin + Octroide, Hydroxyurea, Interferon α , Mifepristone

Medications for Ischemic Stroke

	MEDICATIONS
Treatment	Chlomethiazole Antithrombotic therapy: Heparin
Prevention	Antiplatelets agents: Aspirin, Dipyridamol, Ticlopidine, Clopidogrel
	Streptokinase, Calcium channel blockers, Chlormethiazol, Cititcolin, Epoprostenol, Fibroblast growth factor, Glycin antagonists, GM-1 ganglioside, Lubeluzole, Magnesium sulphate, Naftidrofuryl, N-Methyl D Aspartate receptor antagonists (Aptiganel, Dextrophan, Dextromethorphan, Dizoeilpine , Ketamine), Oxpentifyline, Tirilazal
	Hyperbaric Oxygen Therapy, Corticosteroids or hyperosmolar diuretics such as glycerol or manitol

Medications for treatment of hemorrhage

INDICATION	MEDICATIONS
Subarachnoid hemorrhage	Nimodipine, Antifibrinolytic drugs: Tranexamic acid or aminocaproic acid, Lipid peroxidation inhibitor: Tirilazad
Intracerebral hemorrhage	Labetalol when blood pressure higher than 170 mmHg

Antibacterial Medications

INDICATION	MEDICATIONS
Frontal lobe brain abscess (secondary to paranasal sinusitis)	Benzyl penicillin + Metronidazol
Temporal lobe & cerebellar abscesses	Chloramphenicol, Ampicillin, Cephalosporin + Metronidazol, Aminoglycoside
Abscesses (secondary to trauma)	Flucloxacillin + Fusidic Acid, Rifampicin, Vancomycin (in case of allergy or bacterial resistance)

Meningeal anthrax	Benzyl penicillin
Neurobrucel-losis	Tetracycline (Doxycycline) + Rifampicin, Streptomycin, Cotrimoxazole
Lyme Disease (early stage)	Tetracycline (Doxycycline), Amoxycyclin+Cefuroxime, Azithromycin Pregnant women or children: Amoxicillin, Phenoxyethylpenicillin, or Erythromycin
Lyme Disease (late stage)	I.V.: Ceftriaxone, Cefotaxime, Benzyl penicillin Tetracycline (Doxycycline)
Meningitis	Penicillin and Chloramphenicol or Cephalosporin Cefotaxime or Ceftriaxime + Ampicillin or Vancomycin when highly Penicillin or Cephalosporin resistant.
Meningitis + head trauma or neurosurgery or CSF shunt	Vancomycin + Cefatazidine
Meningitis in Immuno-compromised patients	Ampicillin + Ceftazidime
Meningitis in allergic patients	Chloramphenicol

Neonatal meningitis	<p>Treatment that is given until results of culture and susceptibility tests are known:</p> <ol style="list-style-type: none"> 1) Ampicilline or Chloramphenicol + Gentamicine 2) Cefotaxime or Ceftazidime+Ampicillin 3) Until 4 weeks: Ampicillin + Cefotaxime or Ampicillin + Aminoglycoside (in case of Penicillin or Cephalosporine resistance, Vancomycin will be added) 4) In Preterm or low birth weight neonates: Vancomycin + Ceftazidine <p>Treatment Benzyl penicillin or Ampicillin, Cefotaxime or Ceftazidin + Gentamicin, Penicillin + Gentamicin</p>
Neonatal meningitis infection of ventriculo-peritoneal state	Ampicillin or Penicillin + Gentamicin
Meningitis (infants 1-3 months)	Ampicillin + Cefotaxime or Ceftriaxone In case of Penicillin or Cephalosporine resistance: Vancomycin
Meningitis (older infants and children)	Cefotaxime, Ceftriaxone, Cephalosporin with or without Ampicillin
	ADJUNCTIVE TREATMENTS
Prevention of deafness	Dexamethasone
High risk patients	Dexamethasone

Severe mental impairment	Dexamethasone
Cerebral edema	Dexamethasone
Very high intracranial pressure	Dexamethasone
Gram-Negative enteric and pseudomonal meningitis	<ol style="list-style-type: none"> 1) Cefotaxime + Gentamicin or Aminoglycoside 2) Ceftozidime + Aminoglycoside 3) Intraventricular Aminoglycoside
Haemophilus influenza meningitis	<p>Treatment</p> <ol style="list-style-type: none"> 1) Cefotaxime or Ceftriaxone 2) Chloramphenicol or Ampicillin for beta lactamase negative strain <p>Prophylaxis</p> <p>Rifampicin</p>
Listeria meningitis	As for Neonatal Meningitis
Meningococcal meningitis	<p>Treatment</p> <p>Benzyl penicillin or Cefotaxime or Ceftriaxone</p> <p>Prophylaxis</p> <p>Rifampicin or Cyprofloxacin (P.O.)</p> <p>Ceftriaxone (I.M.)</p>
Pneumococcal meningitis	<ol style="list-style-type: none"> 1) Benzyl penicillin or Phenoxymethyl penicillin 2) Cefotaxime or Ceftriaxone 3) Chloramphenicol <p>In case of Cephalosporins resistance: Vancomycin + Rifampicin:</p>
Meningococcal disease infection	<p>Benzyl penicillin before hospitalization</p> <p>In hospital: as for Pneumococcal Meningitis</p>
Actinomycosis	<p>Amoxicillin</p> <p>In case of penicillin allergy: Cephalosporin or Tetracycline</p>

	(Doxycycline)
Nocardiosis	<p>Sulphadiazine with or without Trimethoprim, Co-Trimoxazole, Sulphfurazole.</p> <p>Amikacin, Cyprofloxatine, Erythromycin, Fucidin, Imipenem, Minocycline, Fluoroquinolone, Ceftriaxone, Cefpiron</p> <p>Minocycline, Amikacin, Cyproxacin (all the last 3) + Tetracycline (Doxycycline)</p> <p>In-Vitro studies demonstrated synergy of the following treatments</p> <p>Imipenen or Amikacin and Trimethoprim</p> <p>Imipenen and Cefotaxime</p> <p>Ampicillin and Erythromycin</p> <p>Amikacin and Cefuroxime</p> <p>Amikacin and Co-Trimoxazol</p> <p>Amikacin and Amoxycillin + Clavulanic Acid</p>
Meningitic plague	Chloramphenicol, Streptomycin, Tetracycline (Doxycycline), Gentamycin
Sinusitis causes bacterial meningitis and brain abscess	<p>Amoxycillin with or without Clavulanic acid</p> <p>Co-Triimazole, Cefuroxime, Erthromycine, Azithromycin</p> <p>Severe infection: I. V: Vancomycin, Ceftriaxone or Cefotaxime, Tetracycline (Doxycycline), Erythromycin</p>
Neurosyphilis	<p>Early Stage</p> <p>Benzathine penicillin or Procaine penicillin</p> <p>In case of allergy to penicillin: Tetracycline (Doxycycline), Erythromycin</p> <p>Later Stage</p> <p>Benzyl penicillin, Procaine penicillin + Probenecid,</p> <p>Benzathine penicillin, Tetracycline (Doxycycline)</p> <p>In case of allergy to Penicillin: Chloramphenicol + Chlortetracycline, Erythromycin</p>
Whipples Disease	Benzyl penicillin (or Procaine penicillin) + Streptomycin, Co-

	Trimoxazole with or without steroids, Ceftriaxone, Phenoxymethylpenicillin + Probenecide
Leptospirosis	Penicillin G, Erythromycin, Tetracycline (Doxycycline), Oxytetracycline, Streptomycin, Chloramphenicol
Tetanus	Penicillin + Immunoglobulin
Typhoid Fever	Chloramphenicol + Dexamethasone
Legionnaires Disease	Erythromycin, Rifampicin, Tetracycline (Doxycycline)

Molecules involved in induction and promotion of neuronal growth are also facilitated in their delivery to the central nervous system through use of the BBB permeability modification techniques described herein.

5

Such molecules include, but are not limited to:

Molecules which induce extracellular action

- 1) GPI-linked candidate plasticity gene (CPG-15)
- 2) Neurotrophins
 - 5 a) Nerve Growth Factor (NGF) -super family
 - Neurotrophin - 3 (NT-3)
 - Neurotrophin - 4/5 (NT-4/5)
 - Neurotrophin - 6 (NT-6)
 - Neurotrophin - 7 (NT-7)
 - 10 b) Brain Derived Neurotrophic Factor (BDNF)
 - c) Transforming Growth Factor β (TGF β)-super family
 - Glial Cell line Derived Neurotrophic Factor (GDNF)- family
 - Neurturin (NTN)
 - Persephin (PSP)
 - 15 Artemin (Art)
 - d) Neurokinin or Neuropoitin-super family
 - Ciliary Neurotrophic Factor (CNTF)
 - Leukemia Inhibitory Factor (LIF)
 - Interleukin-6 (IL-6)
 - 20 Cardiotrophin-1 (CT-1)
 - Oncostatin-M
 - e) Non-Neuronal Growth Factor-super family
 - Acidic Fibroblast Growth Factor (a FGF)=FGF 1
 - Basic Fibroblast Growth Factor (b FGF)=FGF 2
 - 25 Epidermal Growth Factor (EGF)
 - Insulin Like Growth Factor (IGF)
 - Bone Morphogenetic Protein (BMP)
 - Osteogenic protein-1 (OP-1)
- 30 Memantine (antagonist to NMDA), a medication for use as a neuroprotective agent, is being tested in patients suffering from Dementia.

Molecules which act on membrane receptors

Trk family: (Trk A, Trk B and Trk C)

Cytoplasmic

Rac

5 Cdc42

Microtubule Associated Protein = MAP 2

Dynein

Kakapo

TNF α

10 Chondroitinase ABC

GAP 43 and CAP 23

Nuclear

Prospero

15 **Molecules Involved in Anti-Apoptotic Processes**

Bcl-2 family

Proteins termed Inhibitors of Apoptosis (IAP)

CEP-1347 (KT7515)

Guanylate cyclase

20 c-GMP dependent protein kinase inhibitor

Herpes Simplex Virus (HSV) Type 2

Basic Fibroblast Growth Factor (b FGF)

Transforming Growth Factor β (TGF β)

Transforming Growth Factor β Receptor Type 2 (T β R-II fusion protein)

25 NF κ B

For some applications, one or more of these molecules are administered in association with SPG modulation as described herein, to reduce apoptosis in the CNS.

Antioxidants as neuroprotective agents

30 Ascorbic Acid

Manganese superoxide dismutase

There is therefore provided, in accordance with a preferred embodiment of the present invention, apparatus for modifying a property of a brain of a patient, including:

5 one or more electrodes, adapted to be applied to a site selected from a group of sites consisting of: a sphenopalatine ganglion (SPG) of the patient and a neural tract originating in or leading to the SPG; and

a control unit, adapted to drive the one or more electrodes to apply a current to the site capable of inducing an increase in permeability of a blood-brain barrier (BBB) of the patient.

10 There is also provided, in accordance with a preferred embodiment of the present invention, apparatus for modifying a property of a brain of a patient, including:

one or more electrodes, adapted to be applied to a site selected from a group of sites consisting of: a sphenopalatine ganglion (SPG) of the patient and a neural tract originating in or leading to the SPG; and

15 a control unit, adapted to drive the one or more electrodes to apply a current to the site capable of inducing an increase in cerebral blood flow of the patient.

There is further provided, in accordance with a preferred embodiment of the present invention, apparatus for modifying a property of a brain of a patient, including:

20 one or more electrodes, adapted to be applied to a site selected from a group of sites consisting of: a sphenopalatine ganglion (SPG) of the patient and a neural tract originating in or leading to the SPG; and

a control unit, adapted to drive the one or more electrodes to apply a current to the site capable of inducing a decrease in cerebral blood flow of the patient.

There is still further provided, in accordance with a preferred embodiment of the present invention, apparatus for modifying a property of a brain of a patient, including:

25 one or more electrodes, adapted to be applied to a site selected from a group of sites consisting of: a sphenopalatine ganglion (SPG) of the patient and a neural tract originating in or leading to the SPG; and

a control unit, adapted to drive the one or more electrodes to apply a current to the site capable of inhibiting parasympathetic activity of the SPG.

30 Preferably, the one or more electrodes are adapted for a period of implantation in the patient greater than about one month.

In a preferred embodiment, the apparatus includes a wire, adapted to connect the control unit to the one or more electrodes, wherein the control unit is adapted to drive the one or more electrodes from a position external to the patient.

5 Alternatively or additionally, the control unit is adapted to drive the one or more electrodes by wireless communication from a position external to the patient. In a preferred embodiment, the apparatus includes an electromagnetic coupling, adapted to couple the control unit and the one or more electrodes. Alternatively or additionally, the control unit is adapted to be in electro-optical communication with the one or more electrodes. Further alternatively or additionally, the control unit is adapted to be in
10 electro-acoustic communication with the one or more electrodes. Still further alternatively or additionally, the control unit is adapted to be implanted in a nasal cavity of the patient.

Preferably, the one or more electrodes are adapted to be implanted in a nasal cavity of the patient. For some applications, at least one of the one or more electrodes
15 includes a flexible electrode, adapted for insertion through a nostril of the patient and to extend therefrom to the site.

The apparatus preferably includes at least one biosensor, adapted to measure a physiological parameter of the patient and to generate a signal responsive thereto. The control unit, in turn, is preferably adapted to modify a parameter of the applied current
20 responsive to the signal. As appropriate, the biosensor may include one or more of the following:

- a blood flow sensor.
- a temperature sensor.
- a chemical sensor.
- 25 • an ultrasound sensor.
- transcranial Doppler (TCD) apparatus.
- laser-Doppler apparatus.
- a systemic blood pressure sensor.
- an intracranial blood pressure sensor.

- a detecting element adapted to be fixed to a cerebral blood vessel, and wherein the control unit is adapted to analyze the signal to detect an indication of a change in blood pressure indicative of a clot.
- 5 • a kinetics sensor (in this case, the control unit is typically adapted to analyze the signal to detect an indication of a change in body disposition of the patient).
- an electroencephalographic (EEG) sensor.
- a blood vessel clot detector.

In a preferred embodiment, the control unit is adapted to configure the current so as to facilitate uptake of a drug through the BBB when the permeability of the BBB is
10 increased.

Alternatively or additionally, the control unit is adapted to configure the current so as to increase a diameter of a blood vessel and allow an embolus that is located at a site in the blood vessel to move from the site in the blood vessel.

Further alternatively or additionally, the control unit is adapted to drive the one
15 or more electrodes to apply the current responsive to an indication of stroke.

Still further alternatively or additionally, the control unit is adapted to drive the one or more electrodes to apply the current responsive to an indication of migraine of the patient.

There is also provided, in accordance with a preferred embodiment of the present
20 invention, a method for modifying a property of a brain of a patient, including:

selecting a site from a group of sites consisting of: a sphenopalatine ganglion (SPG) of the patient and a neural tract originating in or leading to the SPG; and
applying a current to the site capable of inducing an increase in permeability of a blood-brain barrier (BBB) of the patient.

25 There is additionally provided, in accordance with a preferred embodiment of the present invention, a method for modifying a property of a brain of a patient, including:

selecting a site from a group of sites consisting of: a sphenopalatine ganglion (SPG) of the patient and a neural tract originating in or leading to the SPG; and

applying a current to the site capable of inducing an increase in cerebral blood flow of the patient.

There is yet additionally provided, in accordance with a preferred embodiment of the present invention, a method for modifying a property of a brain of a patient,
5 including:

selecting a site from a group of sites consisting of: a sphenopalatine ganglion (SPG) of the patient and a neural tract originating in or leading to the SPG; and

applying a current to the site capable of inducing a decrease in cerebral blood flow of the patient.

10 There is still additionally provided, in accordance with a preferred embodiment of the present invention, a method for modifying a property of a brain of a patient, including:

selecting a site from a group of sites consisting of: a sphenopalatine ganglion (SPG) of the patient and a neural tract originating in or leading to the SPG; and

15 applying a current to the site capable of inhibiting parasympathetic activity of the SPG.

For some applications, the one or more electrodes are adapted for a period of implantation in the patient less than about one week.

There is further provided, in accordance with a preferred embodiment of the
20 present invention, vascular apparatus, including:

a detecting element, adapted to be fixed to a blood vessel of a patient and to generate a signal responsive to energy coming from the blood vessel; and

a control unit, adapted to analyze the signal so as to determine an indication of an embolus in the blood vessel.

25 Preferably, the detecting element includes an energy transmitter and an energy receiver. For example, the energy transmitter may include an ultrasound transmitter or a transmitter of electromagnetic energy.

There is yet further provided, in accordance with a preferred embodiment of the present invention, a method for detecting, including:

30 fixing a detecting element to a blood vessel of a patient;

generating a signal responsive to energy coming from the blood vessel; and analyzing the signal so as to determine an indication of an embolus in the blood vessel.

There is still further provided, in accordance with a preferred embodiment of the present invention, a chemical agent delivery system including:

a chemical agent supplied to a body of a subject for delivery to a site in a central nervous system of the subject via blood of the subject; and

a stimulator for stimulating parasympathetic fibers associated with the sphenopalatine ganglion, thereby to render a BBB of the subject permeable to the chemical agent during at least a portion of the time that the chemical agent is present in the blood.

In a preferred embodiment, the chemical agent is a therapeutic agent. Alternatively or additionally, the chemical agent is a diagnostic agent. For some applications, the diagnostic agent includes a contrast defining agent and the system also includes a contrast sensor which is operative to facilitate a diagnosis. Alternatively or additionally, the diagnostic agent includes an antibody.

In a preferred embodiment, the stimulator includes an electrical stimulator. Alternatively or additionally, the stimulator includes an odorant stimulator. Preferably, the odorant stimulator includes a neuroexcitatory agent.

There is also provided, in accordance with a preferred embodiment of the present invention, a chemical monitoring system including:

a stimulator for stimulating parasympathetic fibers associated with the sphenopalatine ganglion of a body of a subject, thereby to render a BBB of the subject permeable to a chemical supplied to a central nervous system of the subject during at least a portion of the time that the chemical is present in the central nervous system; and

a blood interface unit operative to facilitate analysis of the chemical which has passed through the BBB into blood of the subject.

There is further provided, in accordance with a preferred embodiment of the present invention, a chemical transfer system including:

a stimulator for stimulating parasympathetic fibers associated with the sphenopalatine ganglion of a subject, thereby to render a BBB of the subject permeable to a chemical supplied to a central nervous system of the subject during at least a portion of the time that the chemical is present in the central nervous system.

5 There is still further provided, in accordance with a preferred embodiment of the present invention, a chemical transfer method including:

reducing concentration of a chemical in a central nervous system of a subject by stimulating parasympathetic fibers associated with the sphenopalatine ganglion of the subject, thereby to render a BBB of the subject permeable to the chemical.

10 The present invention will be more fully understood from the following detailed description of the preferred embodiments thereof, taken together with the drawings, in which:

BRIEF DESCRIPTION OF THE DRAWINGS

Fig. 1 is a schematic pictorial view of a fully implantable stimulator for stimulation of the SPG, in accordance with a preferred embodiment of the present invention;

Fig. 2 is a schematic pictorial view of another stimulator for stimulation of the SPG, in accordance with a preferred embodiment of the present invention;

20 Fig. 3 is a schematic block diagram illustrating circuitry for use with the stimulator shown in Fig. 1, in accordance with a preferred embodiment of the present invention;

Fig. 4 is a schematic block diagram illustrating circuitry for use with the stimulator shown in Fig. 2, in accordance with a preferred embodiment of the present invention;

25 Figs. 5A and 5B are schematic illustrations depicting different modes of operation of stimulators such as those shown in Figs. 1 and 2, in accordance with preferred embodiments of the present invention;

Fig. 6 is a schematic illustration of a mode of operation of the stimulators shown in Figs. 1 and 2, synchronized with a drug delivery system, in accordance with a preferred embodiment of the present invention;

5 Fig. 7 is a schematic block diagram illustrating circuitry for use with the stimulator shown in Fig. 1, where the stimulator is driven by an external controller and energy source using a modulator and a demodulator, in accordance with a preferred embodiment of the present invention;

Fig. 8 depicts sample modulator and demodulator functions for use with the circuitry of Fig. 7, in accordance with a preferred embodiment of the present invention;

10 Figs. 9, 10A, and 10B are schematic diagrams illustrating further circuitry for use with implantable stimulators, in accordance with respective preferred embodiments of the present invention;

Figs. 11 and 12 are bar graphs showing experimental data collected in accordance with a preferred embodiment of the present invention; and

15 Fig. 13 is a schematic illustration of a sensor for application to a blood vessel, in accordance with a preferred embodiment of the present invention.

DETAILED DESCRIPTION OF THE INVENTION

Fig. 1 is a schematic pictorial view of a fully-implantable stimulator 4, for stimulation of the sphenopalatine ganglion (SPG) 6 or other parasympathetic site of a patient, in accordance with a preferred embodiments of the present invention. In Fig. 1, a human nasal cavity 2 is shown, and stimulator 4 is implanted adjacent to SPG 6. Branches of parasympathetic neurons coming from SPG 6 extend to the middle cerebral and anterior cerebral arteries (not shown). Preferably, one or more relatively short electrodes 7 extend from stimulator 4 to contact or to be in a vicinity of SPG 6 or of nerves innervating SPG 6 (e.g., postganglionic parasympathetic trunks thereof).

20
25

For some applications, stimulator 4 is implanted on top of the bony palate, in the bottom of the nasal cavity. Alternatively or additionally, the stimulator is implanted at the lower side of the bony palate, at the top of the oral cavity. In this instance, one or more flexible electrodes 7 originating in the stimulator are passed through the palatine bone or posterior to the soft palate, so as to be in a position to stimulate the SPG or its

30

parasympathetic tracts. Further alternatively or additionally, the stimulator may be directly attached to the SPG and/or to its postganglionic parasympathetic trunk(s).

For some applications, stimulator 4 is delivered to a desired point within nasal cavity 2 by removably attaching stimulator 4 to the distal end of a rigid or slightly flexible introducer rod (not shown) and inserting the rod into one of the patient's nasal passages until the stimulator is properly positioned. As appropriate, the placement process may be facilitated by fluoroscopy, x-ray guidance, fine endoscopic surgery (FES) techniques or by any other effective guidance method known in the art, or by combinations of the aforementioned. Preferably, the ambient temperature and/or cerebral blood flow is measured concurrently with insertion. The cerebral blood flow may be measured with, for example, a laser Doppler unit positioned at the patient's forehead or transcranial Doppler measurements. Verification of proper implantation of the electrodes onto the appropriate neural structure may be performed by activating the device, and generally simultaneously monitoring cerebral blood flow.

The passage of certain molecules from cerebral blood vessels into the brain is hindered by the BBB. The endothelium of the capillaries, the plasma membrane of the blood vessels, and the foot processes of the astrocytes all impede uptake by the brain of the molecules. The BBB generally allows only small molecules (e.g., hydrophilic molecules of molecular weight less than about 200 Da, and lipophilic molecules of less than about 500 Da) to pass from the circulation into the brain.

In accordance with a preferred embodiment of the present invention, parasympathetic activation induced by current from stimulator 4 overcomes the resistance to trans-BBB molecular movement generated by the endothelium of the cerebral capillaries and the plasma membrane. For some applications, therefore, stimulator 4 may be used to transiently remove a substantial obstacle to the passage of drugs from the blood to the brain. For example, the stimulator may cyclically apply current for about two minutes, and subsequently have a rest period of between about 1 and 20 minutes.

It is hypothesized that two neurotransmitters play an important role in this change in properties of the BBB -- vasoactive intestinal polypeptide (VIP) and nitric oxide (NO). (Acetylcholine may also be involved.) VIP is a short peptide, and NO is a gaseous molecule. VIP is believed to be a major factor in facilitating plasma protein

extravasation (PPE), while NO is responsible for vasodilation. For some applications, stimulator 4 is adapted to vary parameters of the current applied to the SPG, as appropriate, in order to selectively influence the activity of one or both of these neurotransmitters. For example, stimulation of the parasympathetic nerve at different
5 frequencies can induce differential secretion -- low frequencies cause secretion of NO, while high frequencies (e.g., above about 10 Hz) cause secretion of peptides (VIP).

For other applications, a constant level DC signal, or a slowly varying voltage ramp is applied, in order to block parasympathetic neural activity in affected tissue. Alternatively, similar results can be obtained by stimulating at a rate higher than about
10 10 Hz, because this tends to exhaust neurotransmitters. Thus, stimulator 4 may be configured to induce parasympathetic electrical block, in order to cause vasoconstriction by mimicking the overall effect of chemical block on the SPG. This vasoconstrictive effect may be used, for example, to controllably prevent or reverse the formation of migraine headaches. This technique of electrical treatment of migraines stands in
15 contrast to methods of the prior art, in which pharmacological agents such as lidocaine are used to induce SPG block.

Fig. 2 is a schematic illustration of a stimulator control unit 8 positioned external to a patient's body, in accordance with a preferred embodiment of the present invention. At least one flexible electrode 10 preferably extends from control unit 8, through a
20 nostril 12 of the patient, and to a position within the nasal cavity 14 that is adjacent to SPG 6.

It is to be understood that electrodes 7 (Fig. 1) and 10 may each comprise one or more electrodes, e.g., two electrodes, or an array of microelectrodes. For applications in which stimulator 4 comprises a metal housing that can function as an electrode, then
25 typically one electrode 7 is used, operating in a monopolar mode. Regardless of the total number of electrodes in use, typically only a single or a double electrode extends to SPG 6. Other electrodes 7 or 10 or a metal housing of stimulator 4 are preferably temporarily or permanently implanted in contact with other parts of nasal cavity 2.

Each of electrodes 7 and/or 10 preferably comprises a suitable conductive
30 material, for example, a physiologically-acceptable material such as silver, iridium, platinum, a platinum iridium alloy, titanium, nitinol, or a nickel-chrome alloy. For some applications, one or more of the electrodes have lengths ranging from about 1 to 5 mm,

and diameters ranging from about 50 to 100 microns. Each electrode is preferably insulated with a physiologically-acceptable material such as polyethylene, polyurethane, or a co-polymer of either of these. The electrodes are preferably spiral in shape, for better contact, and may have a hook shaped distal end for hooking into or near the SPG.

5 Alternatively or additionally, the electrodes may comprise simple wire electrodes, spring-loaded "crocodile" electrodes, or adhesive probes, as appropriate.

In a preferred embodiment of the invention, each one of electrodes 7 and/or 10 comprises a substantially smooth surface, except that the distal end of each such electrode is configured or treated to have a large surface area. For example, the distal tip
10 may be porous platinized. Alternatively or additionally, at least the tip of electrode 7 or 10, and/or a metal housing of stimulator 4 includes a coating comprising an anti-inflammatory drug, such as beclomethasone sodium phosphate or beclomethasone phosphate. Alternatively, such an anti-inflammatory drug is injected or otherwise applied.

15 Fig. 3 is a schematic block diagram illustrating circuitry comprising an implanted unit 20 and an external unit 30, for use with stimulator 4 (Fig. 1), in accordance with a preferred embodiment of the present invention. Implanted unit 20 preferably comprises a feedback block 22 and one or more sensing or signal application electrodes 24. Implanted unit 20 typically also comprises an electromagnetic coupler 26, which
20 receives power and/or sends or receives data signals to or from an electromagnetic coupler 28 in external unit 30.

External unit 30 preferably comprises a microprocessor 32 which receives an external control signal 34 (e.g., from a physician or from the patient), and a feedback signal 36 from feedback block 22. Control signal 34 may include, for example,
25 operational parameters such as a schedule of operation, patient parameters such as the patient's weight, or signal parameters, such as desired frequencies or amplitudes of a signal to be applied to the SPG. If appropriate, control signal 34 can comprise an emergency override signal, entered by the patient or a healthcare provider to terminate stimulation or to modify it in accordance with a predetermined program. Microprocessor
30 32, in turn, preferably processes control signal 34 and feedback signal 36 so as to determine one or more parameters of the electric current to be applied through electrodes 24. Responsive to this determination, microprocessor 32 typically generates an

electromagnetic control signal 42 that is conveyed by electromagnetic coupler 28 to electromagnetic coupler 26. Control signal 42 preferably corresponds to a desired current or voltage to be applied by electrodes 24 to SPG 6, and, in a preferred embodiment, inductively drives the electrodes. The configuration of couplers 26 and 28 and/or other circuitry in units 20 or 30 may determine the intensity, frequency, shape, monophasic or biphasic mode, or DC offset of the signal (e.g., a series of pulses) applied to designated tissue.

Power for microprocessor 32 is typically supplied by a battery 44 or, optionally, another DC power supply. Grounding is provided by battery 44 or a separate ground 46. If appropriate, microprocessor 32 generates a display signal 38 that drives a display block 40 of external unit 30. Typically, but not necessarily, the display is activated to show feedback data generated by feedback block 22, or to provide a user interface for the external unit.

Implanted unit 20 is preferably packaged in a case made of titanium, platinum or an epoxy or other suitable biocompatible material. Should the case be made of metal, then the case may serve as a ground electrode and, therefore, stimulation typically is performed in a monopolar mode. Alternatively, should the case be made of biocompatible plastic material, two electrodes 24 are typically driven to apply current to the SPG.

For some applications, the waveform applied by one or more of electrodes 24 to designated tissue (e.g., the SPG) comprises a waveform with an exponential decay, a ramp up or down, a square wave, a sinusoid, a saw tooth, a DC component, or any other shape known in the art to be suitable for application to tissue. Alternatively or additionally, the waveform comprises one or more bursts of short shaped or square pulses -- each pulse preferably less than about 1 ms in duration. Generally, appropriate waveforms and parameters thereof are determined during an initial test period of external unit 30 and implanted unit 20. For some applications, the waveform is dynamically updated according to measured physiological parameters, measured during a period in which unit 20 is stimulating the SPG, and/or during a non-activation (i.e., standby) period.

In the case of migraine treatment, the waveform may take the form of a slowly varying shape, such as a slow saw tooth, or a constant DC level, intended to block outgoing parasympathetic messaging.

Fig. 4 is a schematic block diagram of circuitry for use, for example, in conjunction with control unit 8 (Fig. 2), in accordance with a preferred embodiment of the present invention. An external unit 50 comprises a microprocessor 52 supplied by a battery 54 or another DC power source. Grounding may be provided by battery 54 or by a separate ground 56. Microprocessor 52 preferably receives control and feedback signals 58 and 68 (analogous to signal 34 and 36 described hereinabove), and generates responsive thereto a stimulation signal 64 conveyed by one or more electrodes 66 to the SPG or other tissue. Typically, but not necessarily, feedback signal 68 comprises electrical feedback measured by one or more of electrodes 66 and/or feedback from other sensors on or in the patient's brain or elsewhere coupled to the patient's body. If appropriate, microprocessor 52 generates a display signal 60 which drives a display block 62 to output relevant data to the patient or the patient's physician. Typically, some or all of electrodes 66 are temporarily implanted in the patient (e.g., following a stroke), and are directly driven by wires connecting the external unit to the implanted unit.

Fig. 5A is a graph schematically illustrating a mode of operation of one or more of the devices shown in Figs. 1-4, in accordance with a preferred embodiment of the present invention. Preferably, the effect of the applied stimulation is monitored by means of a temperature transducer at the SPG or elsewhere in the head, e.g., in the nasal cavity. As shown in Fig. 5A for a step (ON/OFF) mode of stimulation, stimulation of the SPG or related tissue is initiated at a time T1, and this is reflected by a measurable rise in temperature (due to increased blood flow). Once the temperature rises to a predetermined or dynamically-varying threshold (e.g., 37 °C), stimulation is terminated (time T2), responsive to which the temperature falls. As appropriate, when the temperature drops to a designated or dynamically-determined point, the stimulation is reinitiated (time T3). Preferably, suitable temperatures or other physiological parameters are determined for each patient so as to provide the optimal treatment. If appropriate, control instructions may also be received from the patient, e.g., to initiate stimulation upon the onset of a migraine headache.

Fig. 5B is a graph schematically illustrating a mode of operation of one or more of the devices shown in Figs. 1-4, in accordance with another preferred embodiment of the present invention. In this embodiment, the amplitude of the waveform applied to the SPG is varied among a continuous set of values (S1), or a discrete set of values (S2), responsive to the measured temperature, in order to achieve the desired performance. It will be appreciated that other feedback parameters measured in the head (e.g., intracranial pressure and/or cerebral blood flow), as well as measured systemic parameters (e.g., heart rate) and subjective patient inputs (e.g., migraine pain = 3/5) may be used in conjunction with or separately from temperature measurements, in order to achieve generally optimal performance of the implanted apparatus.

Fig. 6 is a graph schematically illustrating a mode of operation of one or more of the devices shown in Figs. 1-4, in accordance with a preferred embodiment of the present invention. In this embodiment, a drug is administered to the patient at a constant rate, e.g., intravenously, prior to the initiation of stimulation of the SPG at time T1. Advantageously, this prior generation of heightened concentrations of the drug in the blood tends to provide relatively rapid transfer of the drug across the BBB and into the brain, without unnecessarily prolonging the enhanced permeability of the BBB while waiting for the blood concentration of the drug to reach an appropriate level. Alternatively, for some applications it is desirable to give a single injection of a bolus of the drug shortly before or after initiation of stimulation of the SPG. Typically, combined administration and stimulation schedules are determined by the patient's physician based on the biochemical properties of each drug targeted at the brain.

Fig. 7 is a schematic block diagram showing circuitry for parasympathetic stimulation, which is particularly useful in combination with the embodiment shown in Fig. 1, in accordance with a preferred embodiment of the present invention. An external unit 80 preferably comprises a microprocessor 82 that is powered by a battery 84 and/or an AC power source. Microprocessor 82 is grounded through battery 84 or through an optional ground 86.

In a typical mode of operation, an external control signal 88 is input to microprocessor 82, along with a feedback signal 108 from one or more biosensors 106, which are typically disposed in a vicinity of an implanted unit 100 or elsewhere on or in the patient's body. Responsive to signals 88 and 108, microprocessor 82 preferably

generates a display signal 89 which drives a display 90, as described hereinabove. In addition, microprocessor 82 preferably processes external control signal 88 and feedback signal 108, to determine parameters of an output signal 92, which is modulated by a modulator 94. The output therefrom preferably drives a current through an electromagnetic coupler 96, which inductively drives an electromagnetic coupler 98 of implanted unit 100. A demodulator 102, coupled to electromagnetic coupler 98, in turn, generates a signal 103 which drives at least one electrode 104 to apply current to the SPG or to other tissue, as appropriate.

Preferably, biosensor 106 comprises implantable or external medical apparatus including, for example, one or more of the following:

- a blood flow sensor,
- a temperature sensor,
- a chemical sensor,
- an ultrasound sensor,
- 15 • transcranial Doppler (TCD) apparatus,
- laser-Doppler apparatus,
- a systemic or intracranial blood pressure sensor (e.g., comprising a piezoelectric crystal fixed to a major cerebral blood vessel, capable of detecting a sudden blood pressure increase indicative of a clot),
- 20 • a kinetics sensor, comprising, for example, an acceleration, velocity, or level sensor (e.g., a mercury switch), for indicating body dispositions such as a sudden change in body attitude (as in collapsing),
- an electroencephalographic (EEG) sensor comprising EEG electrodes attached to, or implanted in, the patients head, for indicating changes in neurological patterns, such as symptoms of stroke or migraine,
- 25 • a blood vessel clot detector (e.g., as described hereinbelow with reference to Fig. 13), or
- other monitors of physiological quantities suitable for carrying out the objects of this or other embodiments of the present invention.

Fig. 8 is a schematic illustration showing operational modes of modulator 94 and/or demodulator 102, in accordance with a preferred embodiment of the present invention. The amplitude and frequency of signal 92 in Fig. 7 can have certain values, as represented in the left graph; however, the amplitude and frequency are modulated so that signal 103 has different characteristics.

Fig. 9 is a schematic illustration of further apparatus for stimulation of the SPG, in accordance with a preferred embodiment of the present invention. In this embodiment, substantially all of the processing and signal generation is performed by circuitry in an implanted unit 110 in the patient, and, preferably, communication with a controller 122 in an external unit 111 is performed only intermittently. The implanted unit 110 preferably comprises a microprocessor 112 coupled to a battery 114. Microprocessor 112 generates a signal 116 that travels along at least one electrode 118 to stimulate the SPG. A feedback signal 120 from a biosensor (not shown) and/or from electrode 118 is received by microprocessor 112, which is adapted to modify stimulation parameters responsive thereto. Preferably, microprocessor 112 and controller 122 are operative to communicate via electromagnetic couplers 126 and 124, in order to exchange data or to change parameters. Further preferably, battery 114 is inductively rechargeable by electromagnetic coupling.

Fig. 10A is a schematic illustration of a stimulator 150, in accordance with a preferred embodiment of the present invention. Preferably, substantially all of the electronic components (including an electronic circuit 158 having a rechargeable energy source) are encapsulated in a biocompatible metal case 154. An inductive coil 156 and at least one electrode 162 are preferably coupled to circuit 158 by means of a feed-through coupling 160. The inductive coil is preferably isolated by an epoxy coating 152, which allows for higher efficiency of the electromagnetic coupling.

Fig. 10B is a schematic illustration of another configuration of an implantable stimulator, in accordance with a preferred embodiment of the present invention. Preferably, substantially all of the electronic components (including an inductive coil 176 and an electronic circuit 178 having a rechargeable energy source) are encapsulated in a biocompatible metal case 174. One or more feed-throughs are preferably provided to enable coupling between at least one electrode 182 and the electronic circuit, as well

as between inductive coil 176 and another inductive coil (not shown) in communication therewith.

With reference to Figs. 10A and 10B, the energy source for electronic circuits 158 and 178 may comprise, for example, a primary battery, a rechargeable battery, or a super capacitor. For applications in which a rechargeable battery or a super capacitor is used, any kind of energizing means may be used to charge the energy source, such as (but not limited to) standard means for inductive charging or a miniature electromechanical energy converter that converts the kinetics of the patient movement into electrical charge. Alternatively, an external light source (e.g., a simple LED, a laser diode, or any other light source) may be directed at a photovoltaic cell in the electronic circuit. Further alternatively, ultrasound energy is directed onto the implanted unit, and transduced to drive battery charging means.

Figs. 11 and 12 are bar graphs showing experimental results obtained during rat experiments performed in accordance with a preferred embodiment of the present invention. A common technique in monitoring bio-distribution of materials in a system includes monitoring the presence and level of radio-labeled tracers. These tracers are unstable isotopes of common elements (e.g., Tc, In, Cr, Ga, and Gd), conjugated to target materials. The chemical properties of the tracer are used as a predictor for the behavior of other materials with similar physiochemical properties, and are selected based on the particular biological mechanisms that are being evaluated. Typically, a patient or experimental animal is placed on a Gamma camera, or target tissue samples can be harvested and placed separately into a well counter. For the purpose of the present set of experiments which were performed, the well counter method was chosen due to its higher sensitivity and spatial resolution. A series of experiments using ⁹⁹Tc-DTPA (DTPA molecule conjugated to a 99-Technetium isotope) were performed. The molecular weight of ⁹⁹Tc-DTPA is 458 Da, its lipophilicity is negative, and its electric charge is +1. These parameters are quite similar with pharmacological agents used in standard chemotherapy, such as tamoxifen, etoposide and irinotecan.

Figs. 11 and 12 show results obtained using ⁹⁹Tc-DTPA penetration assays using ordinary brain sampling techniques (Fig. 11) and peeled brain techniques (Fig. 12). The x-axis of each graph represents different experimental runs, and the y-axis of each graph is defined as: $[(\text{hemisphere radioactivity}) / (\text{hemisphere weight})] / [(\text{total$

injected radioactivity) / (total animal weight)]. The results obtained demonstrate an average 2.5-fold increase in the penetration of ⁹⁹Tc-DTPA to the rat brain. It is noted that these results were obtained by unilateral stimulation of the SPG. The inventors believe that bilateral SPG stimulation will approximately double drug penetration,
5 relative to unilateral SPG stimulation.

In both Fig. 11 and Fig. 12, some animals were designated as control animals, and other animals were designated as test animals. In each group, the left and right hemispheres were tested separately, and the height of each bar represents, for a given animal and a given hemisphere, the normalized level of radioactivity as defined above.
10 Thus, Fig. 11 shows results from a total of four test hemispheres and four control hemispheres. Fig. 12 shows results from six test hemispheres and fourteen control hemispheres. The juxtaposition of control and test bars in the bar graphs is not meant to imply pairing of control and test hemispheres.

Fig. 13 is a schematic illustration of acoustic or optical clot detection apparatus
15 202, for use, for example, in providing feedback to any of the microprocessors or other circuitry described hereinabove, in accordance with a preferred embodiment of the present invention. The detection is preferably performed by coupling to a major blood vessel 200 (e.g., the internal carotid artery or aorta) a detecting element comprising an acoustic or optical transmitter/receiver 206, and an optional reflecting surface 204.
20 Natural physiological liquids may serve as a mediating fluid between the device and the vessel. Preferably, the transmitter/receiver generates an ultrasound signal or electromagnetic signal which is reflected and returned, and a processor evaluates changes in the returned signal to detect indications of a newly-present clot. Alternatively, a transmitter is placed on side of the vessel and a receiver is placed on the
25 other side of the vessel. In either case, for some applications, more than one such apparatus 202 are placed on the vessel, in order to improve the probability of successful clot detection for possible estimation of the clot's direction of motion within the vessel, and to lower the false alarm (i.e. false detection) rate.

Embodiments of the present invention have many medical applications. For
30 example, chemotherapeutic drugs need to pass into cerebral tissue in order to treat brain tumors. Most of the chemotherapeutic drugs have molecular weights of 200-1200 Da, and thus their transport through the blood-brain barrier (BBB) is highly restricted. To

overcome the impedance of the BBB, an intracarotid infusion of high osmotic load has been used in the prior art in order to open the tight junctions of the BBB for a very short period (e.g., 25 minutes), during which the medications are given. This procedure is not simple -- it is invasive, requires general anesthesia, requires subsequent intensive care,
5 and is in any case relatively expensive. For these reasons, such intracarotid infusions are used only in very few healthcare facilities, even though some reports claim a substantial improvement in life expectancy in patients receiving chemotherapy in this manner.

Preferably, embodiments of the present invention which facilitate increased trans-BBB drug delivery, and therefore more efficient chemotherapy, also enable a
10 reduction or elimination of the need for radiotherapy. It is noted that such irradiation of the brain is indicated in the literature to be a significant cause of long-term cognitive and other deficits.

The better delivery of drugs, as provided in accordance with a preferred embodiment of the present invention, is also a factor in the treatment of other disorders,
15 such as CNS infections, Parkinson's disease, Alzheimer's disease, and other neurological diseases. For some applications, the trans-BBB delivery of various growth factors is facilitated using the techniques described herein. Growth factors are typically large molecules that stimulate the growth of neurons, and may be used to treat degenerative disorders, such as Parkinson's disease, Alzheimer's disease, and Motor Neuron Diseases
20 (e.g., Lou Gehrig's disease).

Another preferred application of the present invention includes facilitating drug delivery across the BBB in order to treat inflammation in the brain, e.g., for cases of infectious diseases of the brain in immunocompromised patients. Similarly, medications to treat AIDS may be more effectively administered to sites in the brain through the
25 BBB, when appropriate, through the use of methods and apparatus described herein. A further application of some embodiments of the present invention includes the delivery through the BBB of viruses that are agents of gene therapy (e.g., for treating Parkinson's disease). Similarly, methods and apparatus described herein may be used for treating metabolic disorders of the brain, such as GM2 gangliosidosis.

30 Another aspect of some preferred embodiments of the invention relates to the modulation of cerebral blood flow. Roughly 750,000 Americans suffer strokes each year. Stroke is the United States' third leading cause of death, killing about 160,000

Americans every year. More than 3 million people in the United States have survived strokes, of whom more than 2 million suffer crippling paralysis, speech loss and lapses of memory. About 85% of strokes are ischemic, i.e., a blood vessel is occluded and its territory is deprived of oxygen supply. A cerebral region that is totally deprived of blood supply is surrounded by a second region of partial lack of supply, whose vitality is at risk. This second region is one of the main targets of some embodiments of the invention -- stimulation of the SPG dilates its vessels, and significantly improves that region's likelihood of survival. If the intervention is given early enough in the event (e.g., a few hours post-stroke), it generally also helps the core region of the stroke, as the thrombus is not yet organized, and dilation of the vessels reintroduces blood supply to the tissue. For some applications, SPG stimulation allows the clot to move from a big vessel to a small vessel, and thus reduce blood supply only from a much smaller volume of the brain (which would, in any case, have been deprived of blood supply had the clot remained in place).

Population-based studies have shown that about 5% of men and 16% of women suffer migraine attacks. Over 80% of these people suffer some degree of headache-related disability. Parasympathetic block (in contrast to stimulation) is known to cause vasoconstriction. An embodiment of the present invention uses electrical or odorant means to induce the vasoconstrictive effect and treat migraine. For example, it may use techniques to block nerve messaging, such as applying a slowly-varying voltage, or in some cases, a constant level DC voltage.

Alzheimer's disease is becoming a major source of disability and financial load with the increase in life expectancy. In recent years, vascular factors have been considered prominent in the pathophysiology of the disease. Current therapy is generally concentrated along one line -- cholinomimetic medications, which can, at most, slow down the deterioration of cognitive function in patients. SPG modulation, as provided in accordance with a preferred embodiment of the present invention, is believed to increase blood flow and oxygen supply to the brain, and therefore help these patients. For this use, permanent stimulators may be implanted in the nasal cavity, for long-term intermittent modulation.

It will be appreciated by persons skilled in the art that the present invention is not limited to what has been particularly shown and described hereinabove. Rather, the

scope of the present invention includes both combinations and subcombinations of the various features described hereinabove, as well as variations and modifications thereof that are not in the prior art, which would occur to persons skilled in the art upon reading the foregoing description. For example, elements which are shown in a figure to be
5 housed within one integral unit may, for some applications, be disposed in a plurality of distinct units. Similarly, apparatus for communication and power transmission which are shown to be coupled in a wireless fashion may be, alternatively, coupled in a wired fashion, and apparatus for communication and power transmission which are shown to be coupled in a wired fashion may be, alternatively, coupled in a wireless fashion.

10

CLAIMS

1. A chemical agent delivery system comprising:
a chemical agent supplied to a body of a subject for delivery to a site in a central nervous system of said subject via blood of said subject; and a stimulator for stimulating
5 parasympathetic fibers associated with the sphenopalatine ganglion, thereby to render a blood brain barrier (BBB) of said subject permeable to said chemical agent during at least a portion of the time that said chemical agent is present in said blood.
2. A chemical agent delivery system according to claim 1 and wherein said chemical agent is a therapeutic agent.
- 10 3. A chemical agent delivery system according to claim 1 and wherein said chemical agent is a diagnostic agent.
4. A chemical agent delivery system according to claim 3 and wherein said diagnostic agent comprises a contrast defining agent and wherein said system also comprises a contrast sensor which is operative to facilitate a diagnosis.
- 15 5. A chemical agent delivery system according to claim 3 and wherein said diagnostic agent comprises an antibody.
6. A chemical agent delivery system according to any of claims 1 - 5 and wherein said stimulator comprises an electrical stimulator.
7. A chemical agent delivery system according to any of claims 1 - 5 and wherein
20 said stimulator comprises an odorant stimulator.
8. A chemical agent delivery system according to claim 7 and wherein said odorant stimulator comprises a neuroexcitatory agent.
9. A chemical monitoring system comprising:
a stimulator for stimulating parasympathetic fibers associated with a
25 sphenopalatine ganglion of a body of a subject, thereby to render a blood brain barrier (BBB) of the subject permeable to a chemical disposed in a central nervous system of said subject during at least a portion of the time that said chemical is present in said central nervous system; and
a blood interface unit operative to facilitate analysis of said chemical which has
30 passed through said BBB into blood of said subject.

10. A chemical transfer method comprising reducing concentration of a chemical in a central nervous system of a subject, by stimulating parasympathetic fibers associated with the sphenopalatine ganglion of said subject thereby to render a blood brain barrier (BBB) of said subject permeable to said chemical.

5

FIG. 1

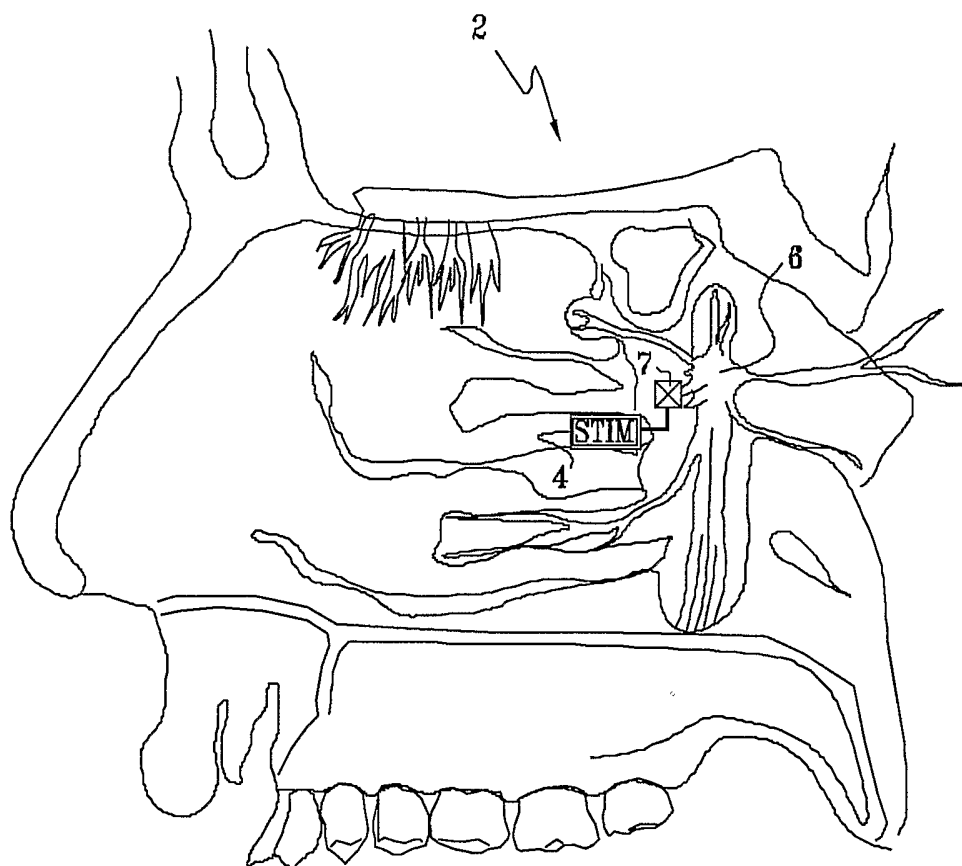

FIG. 2

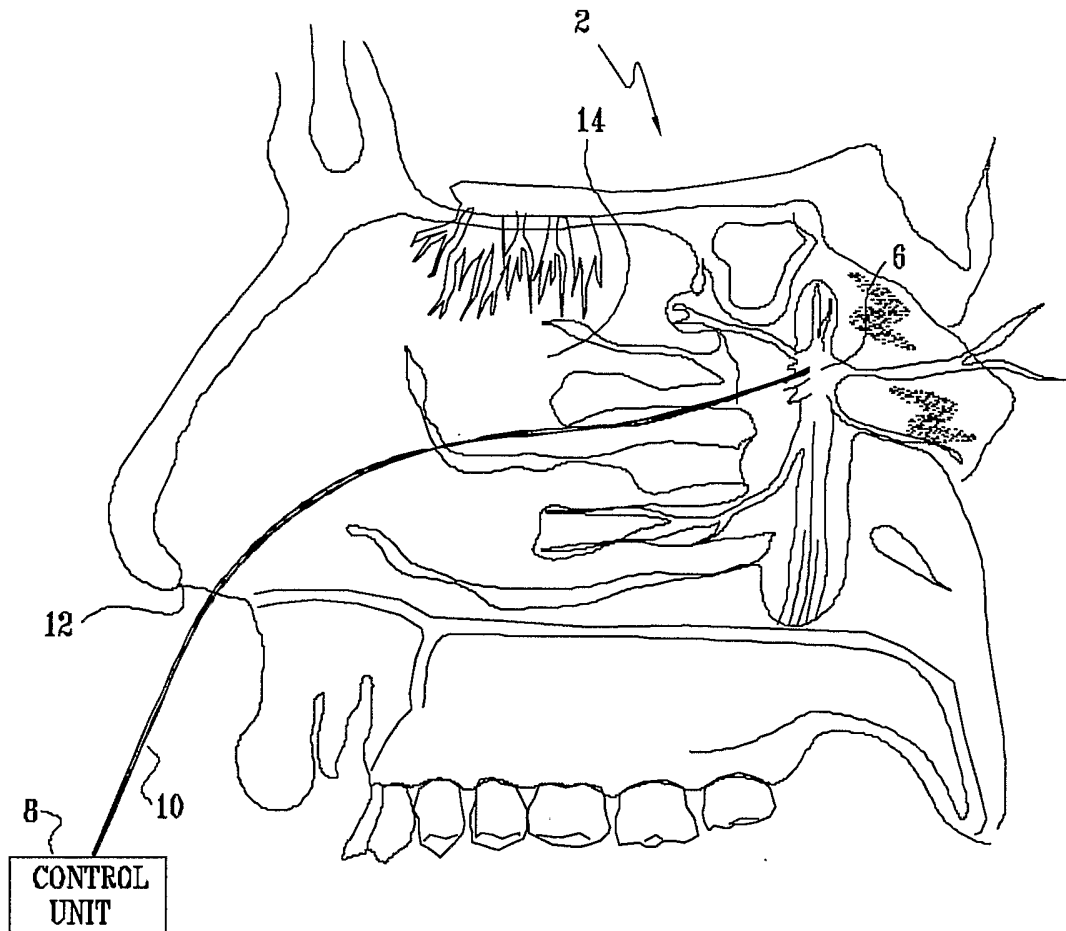

FIG. 3

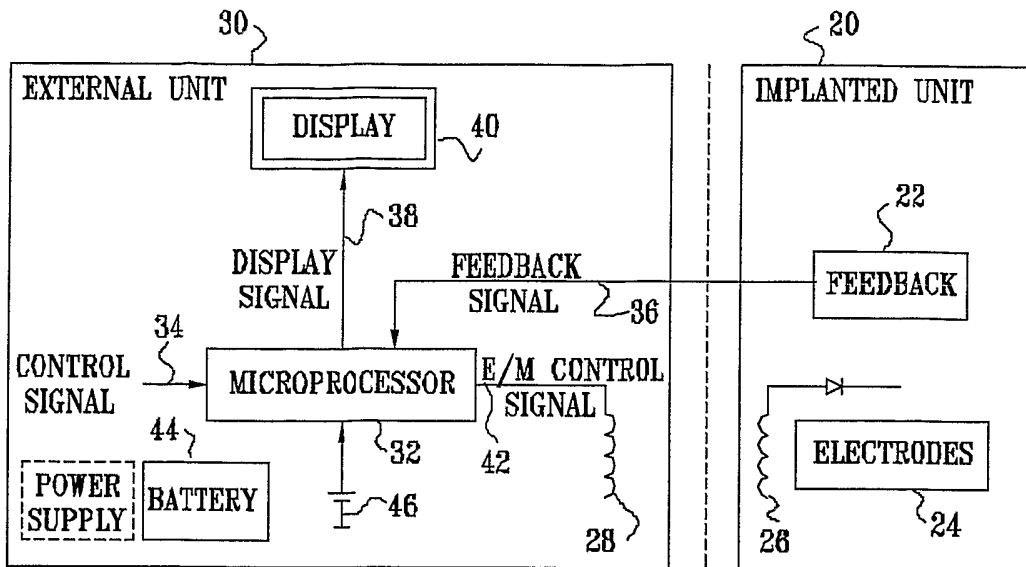
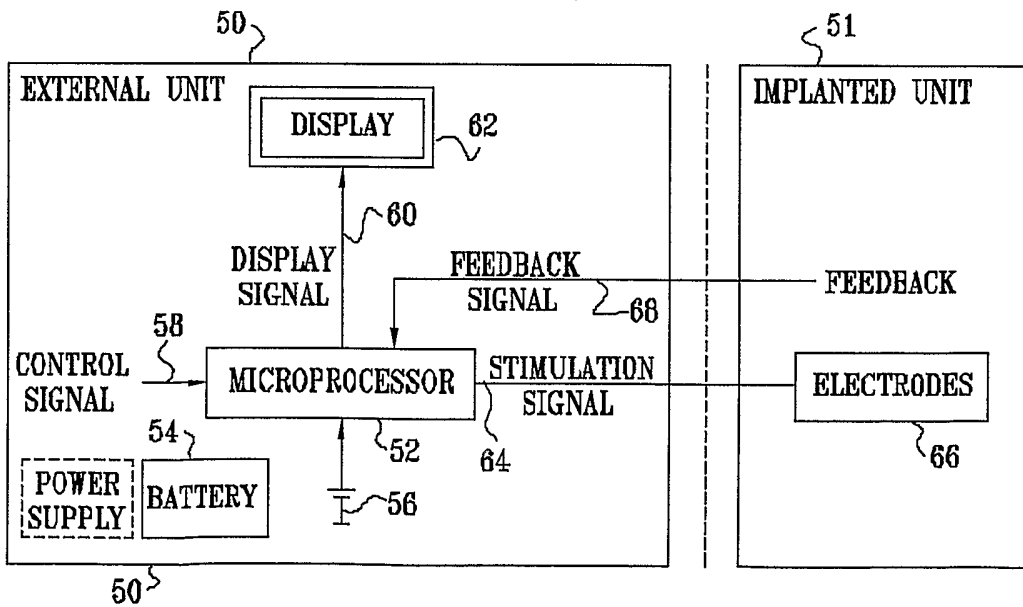

FIG. 4



4/8

TEMPERATURE
(°C)

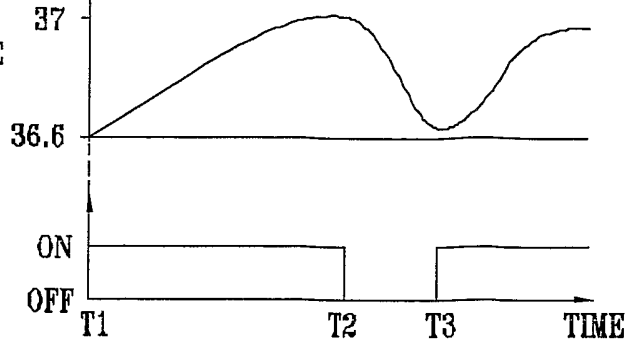

FIG. 5A

FIG. 5B

TEMPERATURE
(°C)

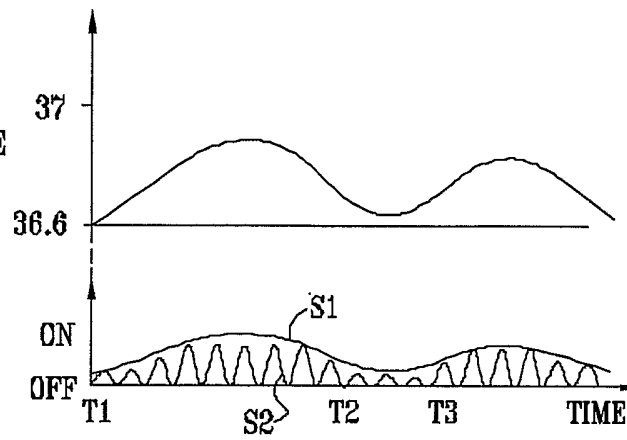

FIG. 6

DRUG
APPLICATION
RATE

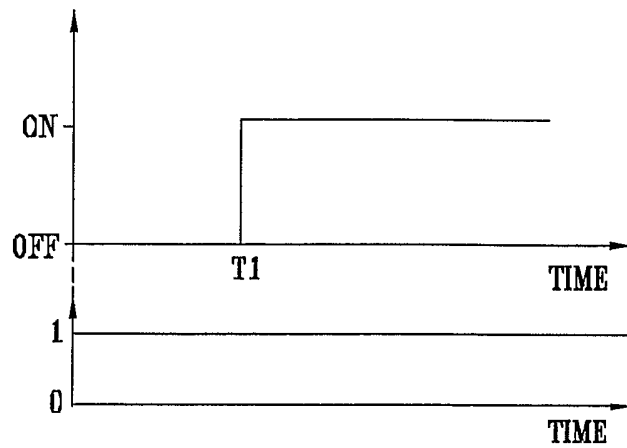

FIG. 7

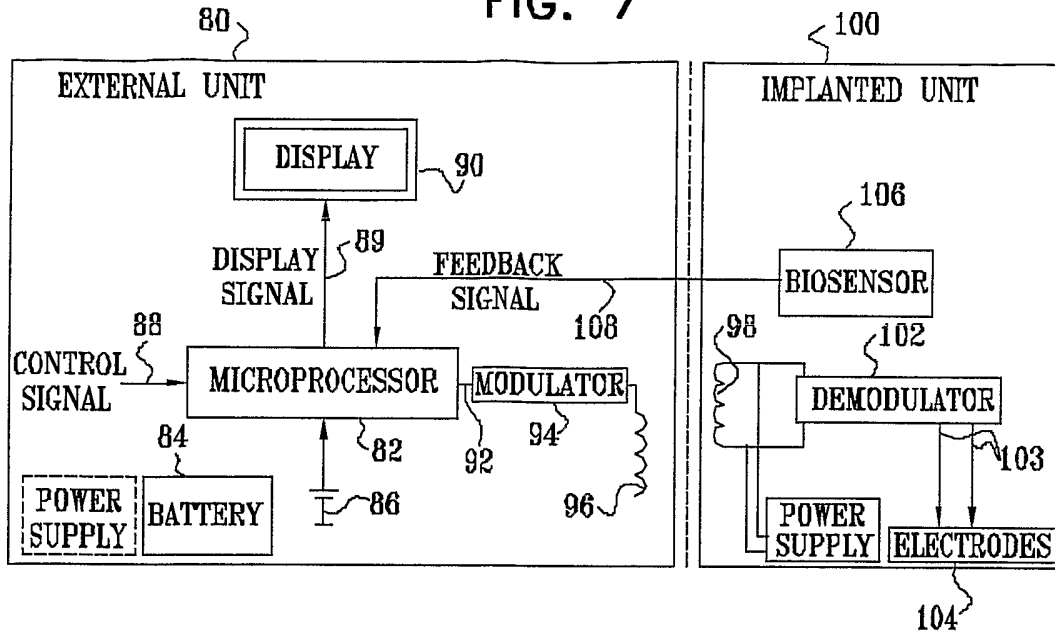

FIG. 8

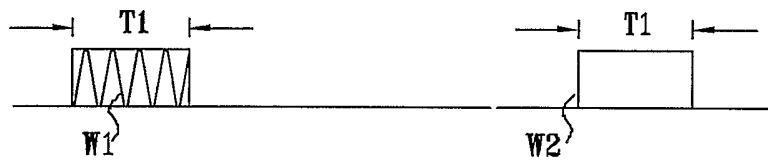

FIG. 9

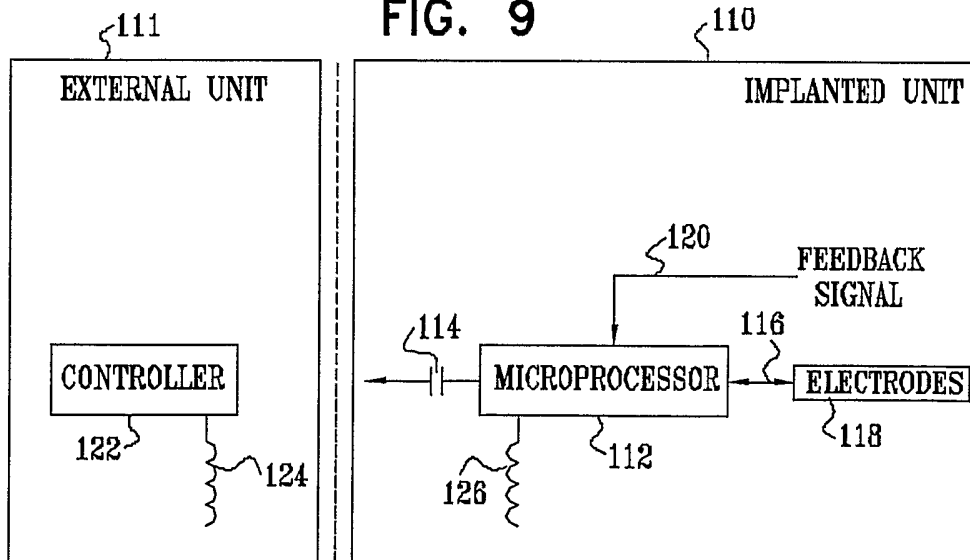

FIG. 10A

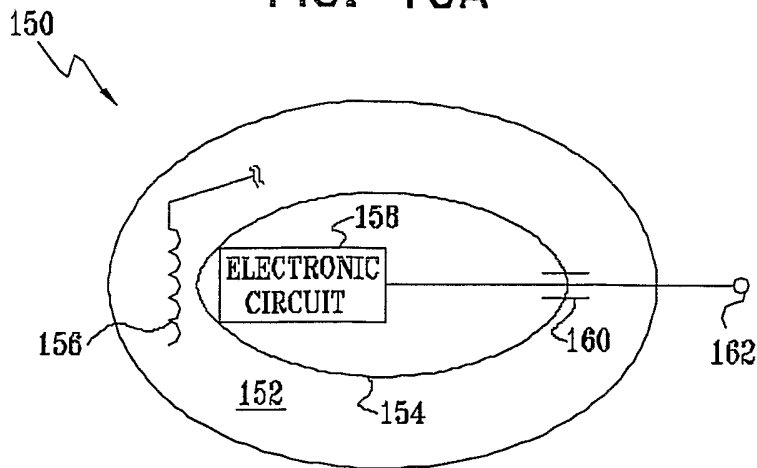

FIG. 10B

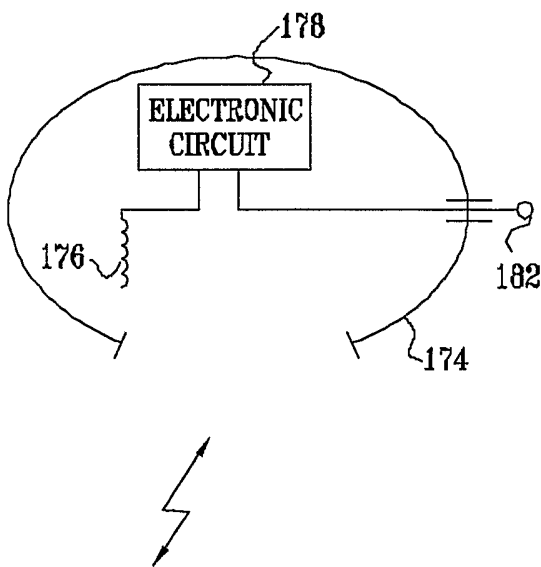
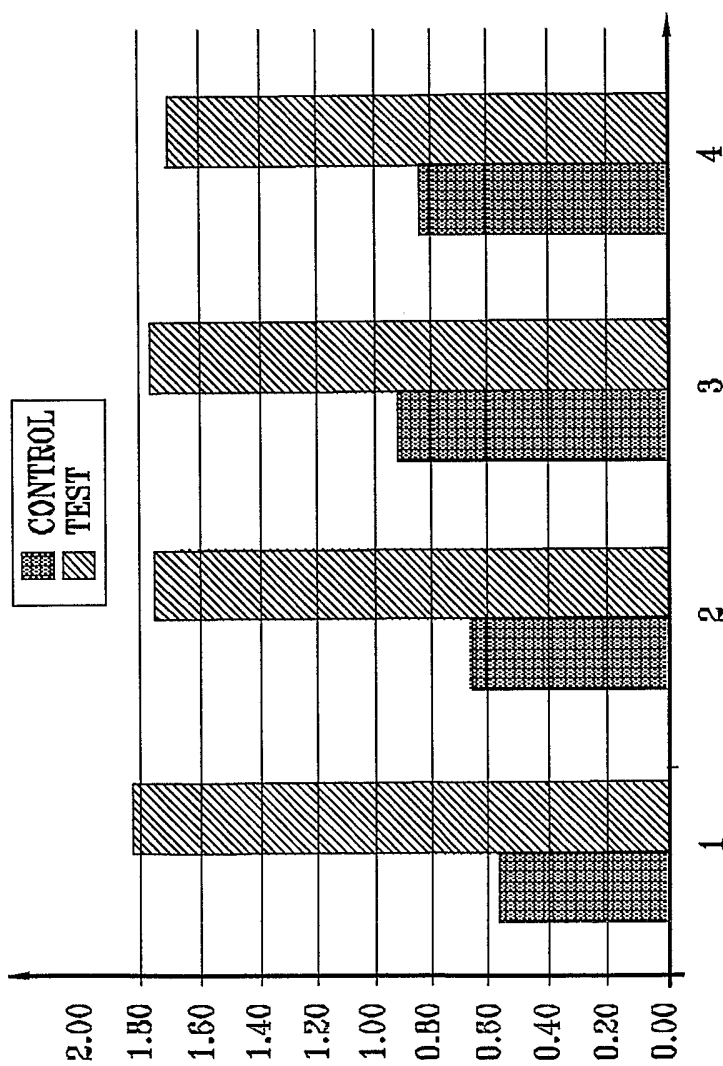

FIG. 11



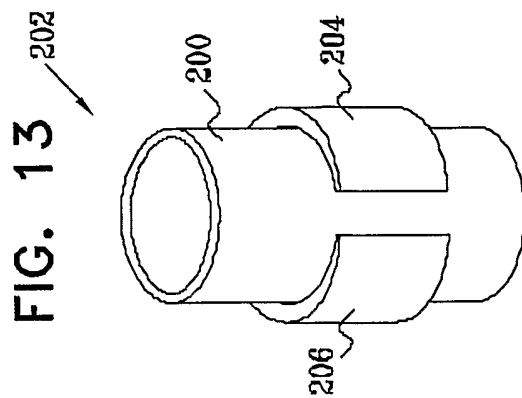

FIG. 12

