

Dec. 24, 1935.

A. B. BROWN

2,025,437

GARMENT HANGER

Filed Feb. 18, 1935

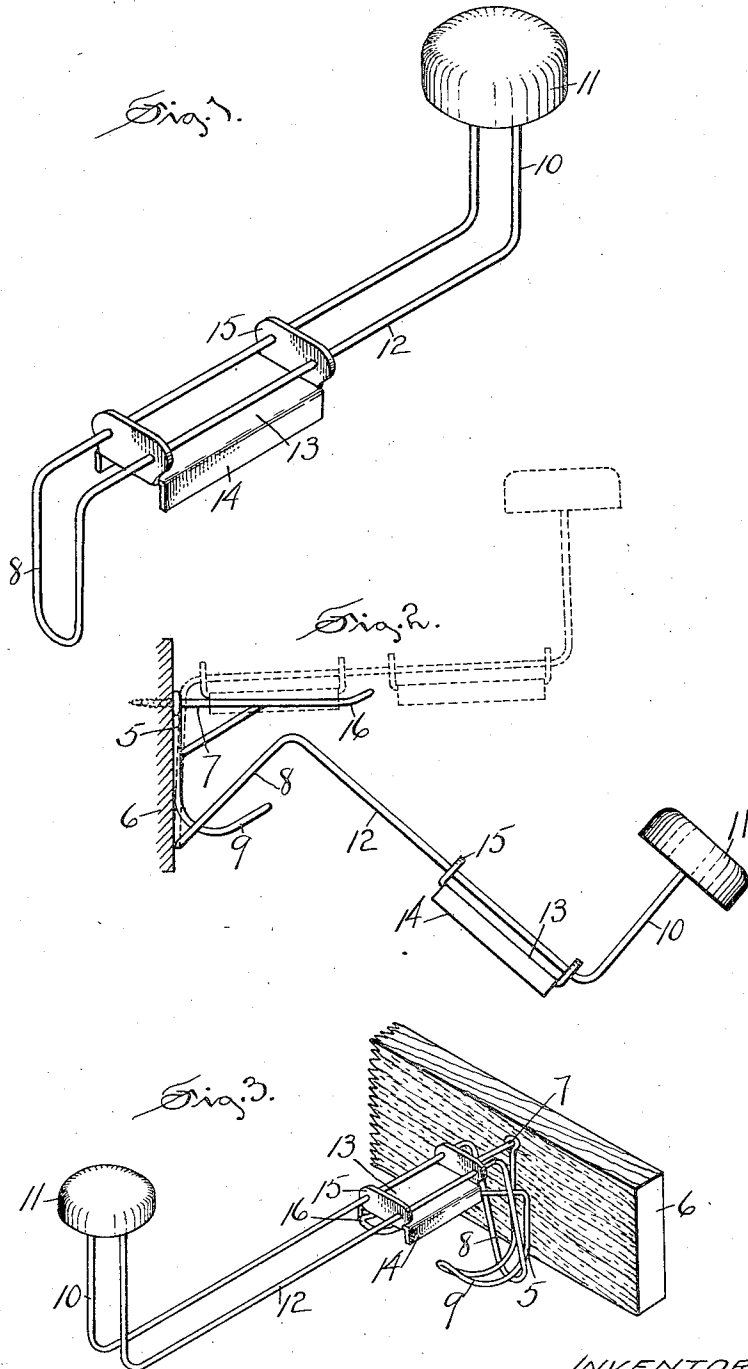

INVENTOR  
Amie Brooks Brown,  
by  
Arthur B. Deuker,  
ATTORNEY

# UNITED STATES PATENT OFFICE

2,025,437

## GARMENT HANGER

Annie Brooks Brown, West Hartford, Conn.

Application February 18, 1935, Serial No. 7,049

3 Claims. (Cl. 211—32)

My invention relates to devices which may be affixed to wardrobe hooks for the purpose of receiving garment hangers, and an object of my invention, among others, is the provision of a support of this kind that shall be simple in construction, efficient for the uses for which it is designed, and which may be readily attached and removed from wardrobe hooks in common use at the present time.

One form of a support embodying my invention and in the construction and use of which the objects herein set out, as well as others, may be attained is illustrated in the accompanying drawing in which

Figure 1 is an isometric view of my improved garment hanger and attachment.

Figure 2 is a view illustrating the manner of use of my improved attachment and support.

Figure 3 is an isometric view showing the attachment in place upon a wardrobe hook.

In the accompanying drawing the numeral 5 denotes a wardrobe or garment hook which may be of any ordinary construction and which may be secured to a cleat 6 or other support in any suitable manner, in the form of hook herein shown one of the branches 7 of the hook being threaded for the purpose of screwing it into the cleat.

My improved support consists of two branches which are primarily bent into U-shape and this U-shaped structure is bent at one end to form a retainer 8 which engages back of the hook 9 of the garment support and as shown in Fig. 3 of the drawing. The opposite end is bent upwardly to form a hat hook 10 having a button 11 affixed at its end, as by means of holes in the button into which the free ends of the branches 12 comprising the hook 10 are inserted.

A sliding bracket 13 is mounted on the main branch 12 of the support, this bracket consisting of a base with retaining flanges 14 bent downwardly from opposite edges and with guides 15 bent upwardly at opposite ends of the base, and as clearly shown in Fig. 1 of the drawing.

The manner of use consists in securing the garment support to the wardrobe hook as shown in Fig. 3, the attachment when being placed having the U-shaped retainer 8 placed back of the hook 9 in the manner shown in Fig. 2. The attachment is then raised into the position shown in Fig. 2, the sliding bracket being in the position shown in dotted lines at the forward part of the support. The bracket is then slid backwardly

into the position shown in dotted lines at the rear end of the support and overlying the upper hook 16 of the wardrobe hook and as shown in Fig. 3 of the drawing.

When thus placed in position the attachment and support is very closely held in place and it is of such length that a half dozen or more garment hangers of the ordinary type may be suspended from the branches 12 of the attachment and support. When in this position a hat may be supported upon the button 11 and above the garments suspended from the branches 12. The attachment is light in structure so that one or more may be readily carried in a suitcase or traveling bag and when required for use they may be readily attached to the ordinary wardrobe hook found in closets of hotels and other places provided for the accommodation of travelers.

I claim:

1. A garment hanger composed of wire bent into U-shape and comprising substantially parallel branches, a retainer bent downwardly at the rear end of said branches, and a supporting bracket slidably mounted on said branches and consisting of an elongated plate having downturned flanges at opposite side edges said plate comprising an elongated rest for the hanger upon a support and said flanges providing guides for sliding movement of said plate, said branches being upturned at the end opposite said retainer and having a button attached thereto.

2. A garment hanger composed of wire bent into U-shape and comprising supporting branches arranged substantially parallel, a retainer at the rear end of said branches, and a sliding bracket comprising an elongated plate having upturned guides at opposite ends with holes therethrough through which the branches of the support extend.

3. A garment hanger formed of wire bent into U-shape and including branches arranged substantially parallel with a downwardly bent retainer at one end and an upturned support at the opposite end, and a supporting bracket comprising an elongated plate having upturned guides at opposite ends with holes therein for slidably mounting said plate on said branches, said plate also including downturned flanges at opposite side edges to support said device against lateral movement.

ANNIE BROOKS BROWN.