

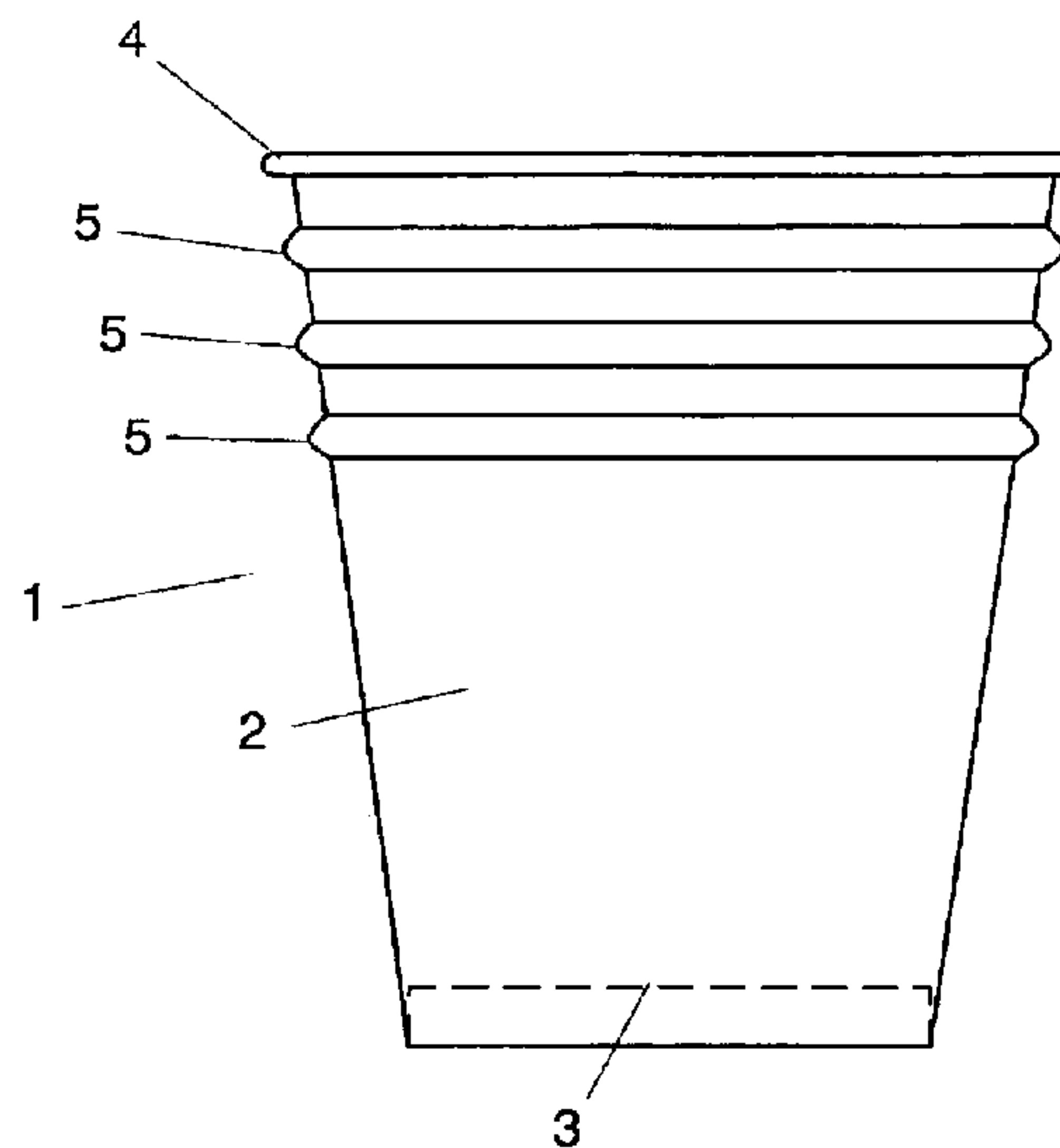

(86) Date de dépôt PCT/PCT Filing Date: 2010/07/06
 (87) Date publication PCT/PCT Publication Date: 2011/01/13
 (45) Date de délivrance/Issue Date: 2018/05/22
 (85) Entrée phase nationale/National Entry: 2012/01/04
 (86) N° demande PCT/PCT Application No.: EP 2010/004071
 (87) N° publication PCT/PCT Publication No.: 2011/003568
 (30) Priorités/Priorities: 2009/07/06 (DE10 2009 026 108.7);
 2009/12/04 (DE10 2009 044 772.5);
 2010/04/09 (DE10 2010 016 390.2)

(51) Cl.Int./Int.Cl. *B65D 1/26* (2006.01),
B65D 81/38 (2006.01)
 (72) Inventeur/Inventor:
 MARSHALL, NEIL, GB
 (73) Propriétaire/Owner:
 HUHTAMAKI OYJ, FI
 (74) Agent: GOWLING WLG (CANADA) LLP

(54) Titre : PROCÉDE POUR LA PRODUCTION D'UNE TASSE ET D'UNE PLURALITE DE TASSES
 (54) Title: PROCESS FOR THE PRODUCTION OF A CUP AND A PLURALITY OF CUPS



(57) **Abrégé/Abstract:**

The present invention relates to a process for the production of a cup having a bottom and a sidewall attached to the bottom, wherein the sidewall preferably comprises a rolled rim at its upper edge opposite to the bottom, wherein the sidewall comprises a single layer or a plurality of layers, wherein at least one of the layers is produced from a paper material, carton, plastic, PLA, a renewable and/or a biodegradable resource and or any other comparable material, wherein at least one shaping is shaped into at least one of the layers of the sidewall, wherein the shaping is at least partially ring-shaped, wherein the shaping extends at least partially over the perimeter of the sidewall, wherein the shaping is inwardly or outwardly directed, wherein the shapings are compressed in height such that an edge of each shaping touches an opposite segment of the shaping and/or that both edges of each shaping touch each other and are joined together, and a cup produced by this process.

WO 2011/003568 A3 

(88) Date of publication of the international search report:
10 March 2011

Process for the production of a cup and a plurality of cups

The present invention relates to a process for the production of a container, for example a cup having a bottom and a sidewall attached to the bottom, wherein the sidewall preferably comprises a rolled rim at its upper edge opposite to the bottom. The container comprises a single or a plurality of sidewalls, wherein at least one of the sidewalls is made from a paper material, a plastic material, PLA, a renewable and/or a biodegradable material and/or any other comparable material or a combination thereof.

Such cups are well known in the prior art, wherein all cups known in the prior art so far have the drawback to feature only a poor rigidity. Such cups have the problem to be very unstable, especially in the region of the upper edge, so that they can easily be pressed together.

In the past, due to this drawback the used material thickness had to exceed a lower limit. In order to provide a sufficiently high rigidity a comparatively thick material had to be used.

The object of the present invention is to suggest a process and a container produced by said process, wherein the container comprises a high inherent rigidity.

According to the present invention, this object is achieved by providing a shaping, for example an embossment, in the sidewall, wherein the shaping extends at least partially over the perimeter of the sidewall, wherein the shaping is inwardly and/or outwardly directed, wherein the shaping is compressed in its height.

The disclosure of this embodiment also applies to other embodiments or the present invention and vice versa.

Due to the compressed shaping, for example an embossment, the cup can only be pressed together in case a very high force is applied to the cup.

The present invention relates to a container. Particularly, the container is a cup, in which beverages, especially hot beverages such as coffee or tea or food, especially soup, mash or the like, can be served. This container is preferably made of paper, thick paper, cardboard, fiber-materials, plastic-material, PLA, materials made from renewable and/or biodegradable

raw materials or a combination thereof. More preferably, the material is plastically deformable, for example embossable. All parts of the inventive containers are made from this material, whereas the individual parts of the container can be made from different materials. Especially the surfaces of the parts of the container that are subjected to a liquid and/or vapor are preferably provided with means, especially a coating, an impregnation, a film or the like which makes these parts at least temporarily resistant against for example humidity, water, aqueous solutions, oil and/or fat or a combination thereof. Preferably the above mentioned means are also heat sealable.

The container according to this present invention comprises a sidewall, which is preferably conically shaped and which more preferably has at its upper end a rolled rim. The sidewall is preferably made from a flat segment, which is subsequently formed, preferably rolled, into its conical shape. Preferably at its lower end, the sidewall is connected to a bottom in order to close the container at the base. The bottom is preferably a separate part which is attached, more preferably glued or heat sealed to the lower end of the sidewall of the container. The sidewall and the base define a filling-volume, which can be filled with a product.

This shaping can be produced by any technique known by a person skilled in the art, e. g. by folding or any other method of plastic deformation. Preferably, the shaping is inserted into the flat segment before it is formed, e. g. rolled into the final shape of the sidewall. More preferably, the shaping is an embossment, which is produced for example by applying locally pressure to the sidewall and deforming the material of the sidewall plastically. The shaping can have any shape known by a person skilled in the art. However, preferably, it is compressible, at least partially, especially in case an axial-force is applied to the sidewall. Preferably the shaping is U-shaped or has partially the shape of a segment of a circle. The shaping can be directed inwardly, i.e. towards the filling-volume of the container and/or outwardly, i.e. away from the filling-volume of the container, whereas an outwardly directed shaping is preferred, because it does not restrict the filling volume of the inventive container. The shaping can alternate between an inward direction and an outward direction. This alternation is preferably harmonic. The shaping is preferably formed into at least one layer of the sidewall such that an edge of each shaping touches an opposite segment of the same shaping and/or that both edges of each shaping touch each other and are joined.

According to a preferred embodiment of the present invention, the shaping, the shaping-dies and/or the compressing tools are capable to generate a void during its formation and/or compression. By means of such a void volume it is possible to realize a very good insulating effect.

According to the present invention, it is, furthermore, preferred that the shaping, the shaping-dies and/or the compressing tools provide capability to generate a flat profile after the compression. Thereby, an exceptionally high rigidity is realized. Besides, the flat profile has the advantage that it can be used as a stop or spacer.

According to a preferred embodiment of the present invention, the shaping is shaped such that a rib is formed during to the compression. By means of a rib the rigidity of the cup can be maximized such that an undesirable crushing of the cup is avoided.

According to the present invention it is, furthermore, preferred that the shaping is heated up for example by means of ultrasonic sound, laser or any other heat sources and, thereby, simplify for the compression. It has turned out that a heated shaping can be compressed with little effort.

According to the present invention, it is, furthermore, preferred that the edges of the shaping are joined together preferably by means of heat bonding and/or cold bonding, by means of sealing, gluing or by any other joining technique, whereas also mechanical joining techniques are included. Thereby, it is assured that the compression does not resume at least partially its uncompressed state.

According to a preferred embodiment of the present invention, a coating is applied at least in the region of the edges of the shaping, wherein the coating preferably comprises a heat-sealable material to join the edges.

The coating is, e. g. polyethylene. Thereby, the coated region is not only impermeable to fluids but it is also possible to seal for example the edges of the compressed shaping together. Preferably, the sealable material is produced from renewable resources. Furthermore, it is preferred that the coating is applied to the entire surface or to parts of the surface, at least the surface that is exposed to water, a watery substance, oil and/or humidity. A coating that is applied on the entire surface can also provide a protection against fluids and moisture.

According to a preferred embodiment of the present invention, the shaping is compressed such that the edges are closely spaced to each other and/or lie on top of each other and preferably form a flat surface.

Due to this compression and the joining an even surface of the sidewall between the edges of the shaping is realized. If these joined edges are formed on the inner surface of the cup, it will be avoided that a filling material, especially a liquid, percolates into the compressed shaping.

According to the present invention, it is preferred that the compressed shaping forms a rib sticking out inwardly or outwardly, wherein the rib comprise void volumes or wherein the ribs form a flat surface. Thereby, it is possible that the shaping can be used for single-sidewall-cups or can be used for the inner-sidewall or the outer-sidewall of multi-sidewall-cups.

According to a further embodiment of the present invention, it is preferred that the compressed shaping serves as insulation or as a spacer for another sidewall, preferably an even sidewall. Thereby, it is possible to achieve an excellent insulation that otherwise could only be realized in extremely cost-intensive process steps.

According to the present invention, it is, furthermore, preferred that the compressed shaping increases the rigidity of the sidewall. Thereby, it is possible that the sidewall is exceptionally solid and rigid without the need to considerably increase the amount of used material.

According to the present invention, it is, furthermore, preferred that the compressed shaping forms a high-frictional grip area.

Thereby, it is possible that even for a single-sidewall cup a well-insulated and grippable grip area is realized, wherein a slipping is effectively avoided due to the surface property and surface texture.

According to the present invention, it is furthermore preferred that the cup is made from a plastic-, a paper material, carton and/or any other fiber material that can be embossed and compressed.

According to the present invention, it is furthermore preferred that the shapings are formed as circumferential rings, ring segments, spirals, spiral segments or the like. Thereby, it is possible to realize many different optical and technical embodiments.

According to a further embodiment of the present invention, it is preferred that an shaping being at least partially circumferential is arranged close to the bottom and serves as stacking support, wherein the shaping is preferably inwardly directed.

Using such a stacking support, that is usually arranged on the sidewall, it is possible to avoid that a plurality of cups stacked into one another are pushed together in such a way that they can be hardly or not separated from each other anymore. Such a stacking support is especially advantageous, if a stack of cups is intended to be separated from each other automatically. According to the present invention, it is preferred that the upper edge or the lower edge of this shaping is pulled further inwards than the other edge. Thereby, it is possible to form a ledge which leads to a tapering of the cup.

According to a further embodiment of the present invention, it is preferred that a plurality of shapings are used which are arranged side by side in vertical direction of the container, wherein towards the bottom the shapings have preferably a smaller radial extension. Thereby, the stackability is significantly improved and/or the stacking height is reduced.

According to the present invention, it is furthermore preferred that the cup comprises a second sidewall, wherein the second sidewall can be single-layered or multi-layered, wherein the second sidewall is wrapped around the first sidewall or wherein the second sidewall is pulled over the first sidewall. The two sidewalls are preferably attached to each other, for example by gluing, sealing or mechanically. Thereby, it is possible that the outer sidewall snaps into place and is, thereby, tightly attached to the inner sidewall.

According to another inventive or preferred embodiment of the present invention, a container with a first sidewall and a bottom is provided, which comprises a fill line which is a shaping. The disclosure of this embodiment also applies to other embodiments of the present invention and vice versa.

According to this embodiment of the present invention, the first sidewall comprises a fill line, which is a shaping. This shaping is a plastic shaping, preferably an embossment, in the first sidewall. Preferably, this shaping extends at least partially, preferably entirely, around the inner or outer circumference of the first sidewall. The shaping can be directed inwardly, i.e. towards the filling-volume of the container or outwardly, i.e. away from the filling-volume of the container, whereas an outwardly directed shaping is preferred, because it does not restrict the filling volume of the inventive container. The height of the shaping at the sidewall will be chosen such, that the filling line represents a desired filling volume. The inventive container can comprise two or more shapings and thus two or more filling lines, for example a lower one which indicated a volume, which has to be filled with a powder and/or pellets and a higher one that indicate the amount of liquid that has to be added to the powder and/or

pellets. The shaping can extend around the entire circumference or can extend only over a segment of the circumference of the sidewall of the container.

This shaping can be produced by any technique known by a person skilled in the art, e. g. by folding or any other method of plastic deformation. Preferably, the shaping is inserted into a cardboard segment before it is formed, e. g. rolled into the final shape of the sidewall. More preferably, the shaping is an embossment, which is produced for example by applying locally pressure on the sidewall and deforming the material of the sidewall plastically. The shaping can have any shape known by a person skilled in the art. However, preferably, it is compressible, at least partially, especially in case an axial-force is applied to the sidewall. Preferably the shaping is U-shaped or has partially the shape of a segment of a circle.

In a preferred embodiment, the shaping is compressed in its height extension, i.e. after the compression of the shaping, the sidewall is reduced in its height. Due to the compression of the shaping in its height, preferably the radial extension of the shaping increases at least partially. More preferably, the compression of the shaping is elastic, i.e. as soon as the deformation force is removed, the shaping tries to resume, at least partially, its original shape. Thus, in this preferred embodiment of the present invention, the deformed shaping functions as a spring.

In another preferred embodiment of the present invention, the flanges and/or edges of the shaping are bonded, preferably glued or sealed, together after they have been compressed. This preferred embodiment of the present invention has the advantage that the shaping is at least partially closed and that the fill line appears as a line with a small width.

In another preferred embodiment, the inventive container comprises a second sidewall, which is preferably arranged around the first sidewall. This second sidewall is preferably conically shaped and is more preferably made from a flat cardboard segment, which is subsequently formed, especially rolled, around the circumference of the first sidewall. Preferably, the second sidewall is connected to the first sidewall and/or the base at one, preferable two or more connection points or connection areas. This connection can be purely mechanical, based on adhesion or a combination thereof. Preferably, the two sidewalls are glued or sealed together.

The shaping functions in this preferred embodiment preferably also a spacer between the first and the second sidewall, especially to maintain an air gap between the first and the

second sidewall, even if the second sidewall is subjected to pressure, for example by the hand of a user.

The second sidewall can be utilized to maintain the shapings in their compressed state, so that the fill line appears as a fine line. Thereto, the two sidewalls are preferably connected in two or more different areas, especially at two or more different heights of the container. The shaping itself or other parts of the first sidewall can be connected to the second sidewall. The second sidewall hinders the compressed shaping to resume its original shape after the compression force has been released.

The inventions are now explained in further detail according to the figures. This explanation does not limit the scope of protection. The explanation apply to all inventions, respectively.

Fig. 1 shows a cup comprising three outwardly directed shapings.

Fig. 2 shows a cup according to Fig. 1 with compressed shapings.

Fig. 3 shows a detailed cutaway view of a compressed shaping.

Fig. 4 shows a schematic illustration of the production process for a cup comprising at least one inwardly directed shaping according to the present invention.

Fig. 5 shows a cutaway view of different compressed shapings, one with a void and one a flat ring.

Fig. 6 shows a drawing of a cup comprising a plurality of outwardly directed shaping and one inwardly directed shaping which serves as stacking support, wherein the outwardly directed shapings are offset from one another in vertical direction.

Fig. 7 shows a cutaway view of two cups stacked into one another.

Fig. 8 shows a first embodiment of the inventive container.

Fig. 9 shows the compression of the shaping.

Fig. 10 shows an inventive container with compressed shapings.

Figure 1 shows a cup 1 with a sidewall 2 and a bottom 3. The upper edge of the sidewall 2 opposite to the bottom 3 comprises a rolled rim 4. According to the illustrated embodiment, three outwardly directed and circumferential shapings 5 are arranged below the rolled rim 4. The shapings 5 are embossments. According to the present invention, the shapings 5 are compressed in height. In the present case the compressed shapings form outwardly directed flat rings 6 as illustrated in Figure 2. The person skilled in the art understands that there can be more or less shapings 5 and that the shapings can be directed inward and/or outwardly. The sidewall 2 is made of paper material or carton and comprises a coating of polyethylene 7 on the inner surface. During the compression of the shapings 5 preferably at least this

coating 7 is heated up so that, in the region of the edges 8 of the shapings 5, the edges 8 of each shaping 5 are heat-sealed together. It is possible to also use other well-known sealable materials, such as sealable materials produced from renewable resources, for the coating 7. The coating 7 can be applied on the entire surface or on parts of the surface of the sidewall of the container. By applying a coating 7 on the entire surface it is possible to avoid that the sidewall 2 is moistened by liquid filling material. The edges 8 can also be glued or mechanically attached to each other.

Furthermore, it is preferred that the sidewall 2 is at least partially made of plastic, PLA and/or renewable and/or biodegradable resources.

Due to the bonding of the edges 8 it is avoided that the shapings 5 which are compressed to rings 6 reopen. Moreover, a comparatively even surface is also realized in the region of the rings 6 on the inner surface of the cup 1. It is avoided that filling material, for example a beverage like coffee tea or a cold drink or a food like soup, percolates into the rings 6.

Furthermore, the rings 6 are, thereby, hermetically sealed. During the compression, the rings 6 are usually not pressed together completely flat so that a void volume 9 is formed inside the rings 6. Besides, it is preferred that the rings 6 are pressed together completely flat by means of an appropriate compressing tool.

The rings 6 stiffen the sidewall 2 of the cup 1. An unintentional compression while holding the cup 1 is avoided. Due to this constructively increased rigidity it is, furthermore, possible to reduce the material thickness of the sidewall 2. Moreover, it is possible to use a softer material.

The rings 6 not only stiffen the sidewall 2 but also serve as a very good insulation, especially for single-sidewall-cups 1. The void volumes 9, thereby, serve as very good heat insulation. Thereby, it is possible to comfortably hold cups filled with hot or cold beverages. Besides, due to the texture formed by the rings 6 a very good slip resistance is provided. It is assured that the cup 1 does not slip unintentionally from the hands of a user.

The rings 6 can also serve as spacer for another sidewall 2. For example, it is possible that the sidewall comprises a second preferably outer sidewall. Three or more sidewall-constructions are also preferred. Furthermore, it is possible that both the inner sidewall and the outer sidewall comprise shapings 5 and/or rings 6. Furthermore, it is preferred that, e. g.,

the rings of the outer sidewall are inwardly directed and the rings of the inner sidewall are outwardly directed.

The joint of the edges 8 cannot only be realized by hot sealing, but also by bonding or the like. For this purpose, it is possible to apply a hot or cold glue in the region of the edges 8, wherein the hot or cold glue generates the joint during or after the compression. A combination of sealable material and glue is also preferred.

By using an excess of sealable material and/or glue it is possible to realize an additional smoothing of the junction of two edges 8.

To compress the shapings 5 it is possible to heat up the shaping using, e. g., ultrasonic sound, laser or other heat sources. The forces required for the compression can, thereby, be reduced. Furthermore, a sealable material is already softened so that a joint is generated as soon as two edges 8 touch each other.

Preferably, prints or figurations can be applied on the outside of the cup 1.

Preferably the shapings 5 have 3 height and 2 mm depth. Other dimensions are possible and depend on the intended rigidity and the used material.

Fig. 4 shows another embodiment of the production process for a cup according to the present invention. The sidewall 42 of the depicted cup 41 comprises a plurality of inwardly directed shapings 45, here embossments. One of these shapings 45 is arranged close to the bottom 3. This bottommost shaping 45 compressed to a ring 46 and serves as stacking support.

In case a plurality of cups 41 is stacked into one another, the lower edge of these cups pushes against this ring 46. Thus, it is avoided that the upper cup is further pushed down. Thereby, it is prevented that cups stacked into one another strongly adhere to each other and cannot or can only hardly be denested.

It is preferred that the other shapings 45 illustrated in this embodiment are compressed as well. Furthermore, it is preferred, that these shapings 45 are outwardly directed.

Any combination of the two illustrated embodiments such as any arrangements 5 and 45, respectively, on the sidewall 2 and 42, respectively, are conceivable as well.

The sidewall 2 and 42, respectively, can be made from a different material. It is conceivable that plastic or any other fiber material is used.

It is possible that the sealable material is any heat-sealable coating, a sealing wax or the like. Sealable materials produced from renewable resources are conceivable. Among these materials are PLA or the like.

It is, furthermore, conceivable, that the shapings 5 and 45, respectively, only comprise segments capable to form a ring 6 together. Besides, it is conceivable that the shapings 5 and 45, respectively, are spiral-shaped, sectionally spiral-shaped or comprise a ring-shaped part.

Furthermore, it is conceivable, that a plurality of shapings 5 and 45, respectively, arranged preferably in the upper region of the cup vary in position and height. Thereby, shapings being positioned closer to the bottom are arranged further inside and comprise a lower depth, respectively. Due to this construction as illustrated in Fig. 6 the stackability of a plurality of cups is improved. The cups can be pushed into one another so that the stacking height is minimized. However, the cups can still be easily denested.

Furthermore, it is conceivable that an outer and optionally multi-layered sidewall 2 is wrapped around the cup and locks with the shapings 5 and 45, respectively. It is also possible that the outer sidewall is pulled over the cup.

Furthermore, it is conceivable that the inner sidewall comprises a flat surface whereas an outer sidewall comprises a or a multitude of shapings 5 and 45.

Figure 8 depicts on the left hand side the inventive container 1 and shows on the right hand side an enlarged partial view of a first sidewall 2 of the container 1. The first sidewall 2 comprises at its upper end a rim 4 and is at its lower end connected to a base 8. The first sidewall 2 and the base 8 define the filling volume 14 of the inventive container. The first sidewall 2 is, in the present case, made from a flat cardboard-segment, which has been formed in the shape of a conus and whose opposite ends have been glued together. Near its top, the first sidewall comprises a shaping 5, which is directed outwardly, i.e. away from the filling volume 14. This shaping has been incorporated into the first sidewall plastically, i.e. by plastic deformation, for example by embossment. Parts of the inner surface of the shaping 5, especially edges 11 can be seen by the user of the container and represents a filling line 12.

The height H in which the filling line 12 is arranged, can be freely chosen according to the desired filling volume. The inventive container can comprise two or more shapings and thus two or more filling lines. In the present case, the shaping 5 has been compressed after it has been inserted into the first sidewall 2 and the flanks 13 and/or the edges 11 have been bonded, preferably glued or sealed to maintain the shaping in its compressed state. Due to the compression of the shaping 5 and its fixture in the compressed state, the filling line is very fine and preferably at least only very little liquid enters into the shaping. The filling line 12 does not reduce the inner diameter of the inventive container.

The compression of the shaping 5 is depicted in figures 9a – 9c. These figures show the compression of the height h of the shaping 5, 10. Figure 9a shows the shaping, here an embossment 5, after it has been plastically introduced into the first sidewall 2. This shaping is subsequently compressed by the axial force F, so that the height h of the shaping decreases. Figure 9b shows a first state of compression, which can be however the final state. Figure 9c depicts, in comparison to figure 9b, a further compression of the embossment 5, in which the edges 12 of the shaping 5 lie on top of each other or at least adjacent to each other. In this state, the height h of the shaping is, in comparison to the embodiment according to figure 9b, even further reduced. In order to maintain the shaping 5 in the compressed state, the flanks 13 and/or the edges 11 of the shaping can be attached to each other, preferably glued or sealed.

An alternative embodiment of the inventive container is depicted in figure 10. Here, the container comprises two shapings 5, 10 and thus two filling lines 12. The lower filling line can be utilized to indicate an amount of powder or pellets to be added to the container. The upper filling line indicates the amount of liquid to be added to the container. The second sidewall 15 is utilized to maintain the shapings 5, 10 in their compressed state as depicted in figures 9b or 9c. This is done by compressing the shapings and holding the shaping in their compressed state, while the second sidewall is connected to the first sidewall either directly at the tip of the shaping 5, 10 or, as here depicted in figure 3, at the rim 4 and at the lower end of the first sidewall 2. As soon as this connection 16, 17 is ridged, the shapings 9, 10 are maintained in their compressed state by the second sidewall 3. The shapings 5, 10 function here also as spacers between the first and the second sidewall, so that an air gap 18 between the two sidewalls is maintained, even if pressure is applied to the second sidewall, for example by a user.

List of reference signs

1	container, cup
2	sidewall, first sidewall
3	bottom
4	rolled rim
5	shaping, embossment
6	compressed shaping, ring, flat ring
7	coating
8	edge of the shaping
9	void, void volume
10	second shaping, second embossment
11	edge of the shaping
12	natural fill line
13	flanks
14	filling volume
15	sidewall, second sidewall
16	connection
17	connection
41	container, cup
42	sidewall of the container, cup
45	shaping, embossment
46	compressed shaping, ring, flat ring
F	compression force for the shaping, axial force
h	height of the shaping
H	height of the container, in which the shaping has been arranged

Claims

1. A container comprising:
 - a bottom,
 - a first sidewall attached to the bottom, wherein the first sidewall is produced from a paper material or carton material, and
 - at least one shaping shaped into the first sidewall, the at least one shaping having two opposing edges, wherein the at least one shaping is at least partially ring-shaped and extends at least partially over a perimeter of the first sidewall, wherein the at least one shaping is inwardly or outwardly directed,
 - wherein the at least one shaping is configured into a compressed shape where a first edge of the two opposing edges contacts a second edge of the two opposing edges, wherein the compressed shape and contacting opposing edges of the shaping provide the first sidewall with increased structural rigidity,
 - wherein the compressed shape of the at least one shaping is secured by a second sidewall, wherein the compression of the at least one shaping is elastic and functions as a spring.
2. The container according to claim 1, wherein the at least one shaping forms a rib directed inwardly and/or outwardly, wherein the rib comprises a void volume or wherein the rib forms a flat surface.
3. The container according to claim 1 or 2, wherein the at least one shaping is an insulation or as a spacer for second sidewall.
4. The container according to claim 1, 2 or 3, wherein the two opposing edges of the at least one shaping are compressed and are joined to one another.
5. The container according to any one of claims 1 to 4, wherein the at least one shaping forms a high-frictional grip area.
6. The container according to any one of claims 1 to 5, wherein the at least one shaping is formed as a circumferential ring, ring segment, spiral, or spiral segment.

7. The container according to any one of claims 1 to 6, wherein the at least one shaping is arranged close to the bottom and serves as stacking support.
8. The container according to claim 7, wherein the first edge or second edge of the at least one shaping is pulled further inwards than the other edge.
9. The container according to any one of claims 1 to 8, wherein the container includes a plurality of shapings, wherein the shapings are arranged side by side in a vertical direction.
10. The container according to any one of claims 1 to 9, wherein the second sidewall can be single-layered or multi-layered, wherein the second sidewall is wrapped around the first sidewall or wherein the second sidewall is pulled over the first sidewall.
11. The container according to any one of claims 1 to 10, wherein the at least one shaping comprises a fill line.
12. The container according to any one of claims 1 to 11, wherein the at least one shaping is compressed in its height (h).
13. The container according to any one of claims 1 to 12, wherein the at least one shaping includes two opposing flanks, and wherein the two flanks and/or the two opposing edges of the at least one shaping are at least partially glued or sealed to one another.
14. The container according to any one of claims 1 to 13, wherein the second sidewall is connected to the first sidewall and/or the bottom at one or more connection points.
15. The container according to claim 1 or 2, wherein the at least one shaping acts as a spacer between the first sidewall and the second sidewall.
16. The container according to any one of claims 1 to 15, wherein the sidewall comprises a rolled rim at its upper edge opposite to the bottom.

17. The container according to claim 1, wherein the two opposing edges of the at least one shaping are aligned with one another and an interior surface of the first sidewall.
18. The container according to claim 17, wherein the two opposing edges lie on top of each other and create a filling line on an interior surface of the first sidewall.
19. The container according to any one of claims 1 to 18, wherein the compressed shape of the at least one shaping reduces the overall height of the first sidewall.
20. The container according to claim 7, wherein the shaping is inwardly directed.
21. The container according to claim 9, wherein towards the bottom the shapings are shifted further inwards.
22. The container according to claim 16, wherein the at least one shaping proximate the bottom of the container has a lower depth than at least one shaping closer to the rolled rim
23. The container according to claim 10, wherein the second sidewall is mechanically locked with the first sidewall.
24. The container according to claim 13, wherein the flanks and/or edges of the shaping are glued or sealed together.
25. The container according to claim 1, wherein the at least one shaping is connected to the second sidewall and the second sidewall prevents the at least one shaping from resuming its original shape after a compression force on the first sidewall has been released.

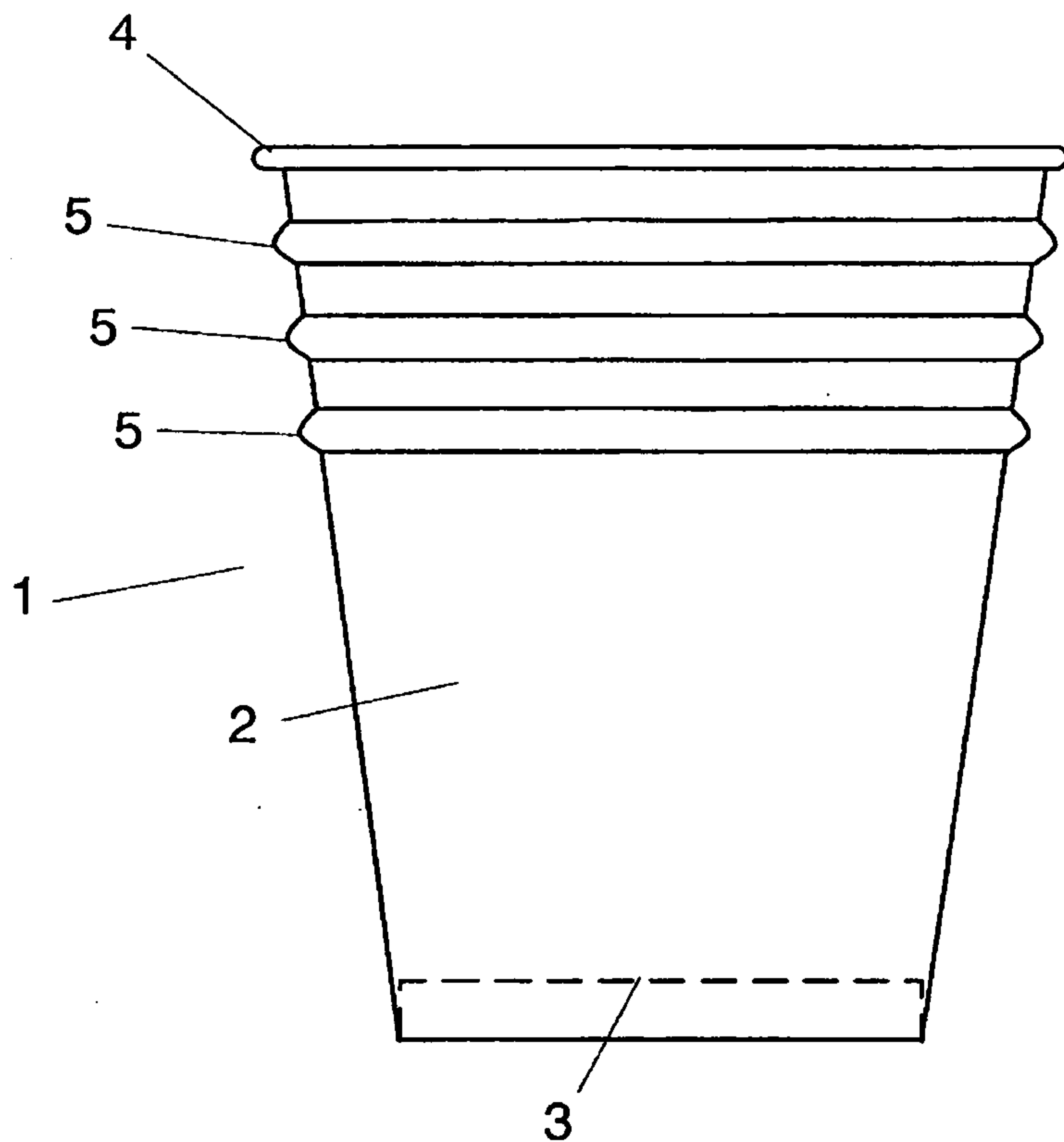

Fig. 1

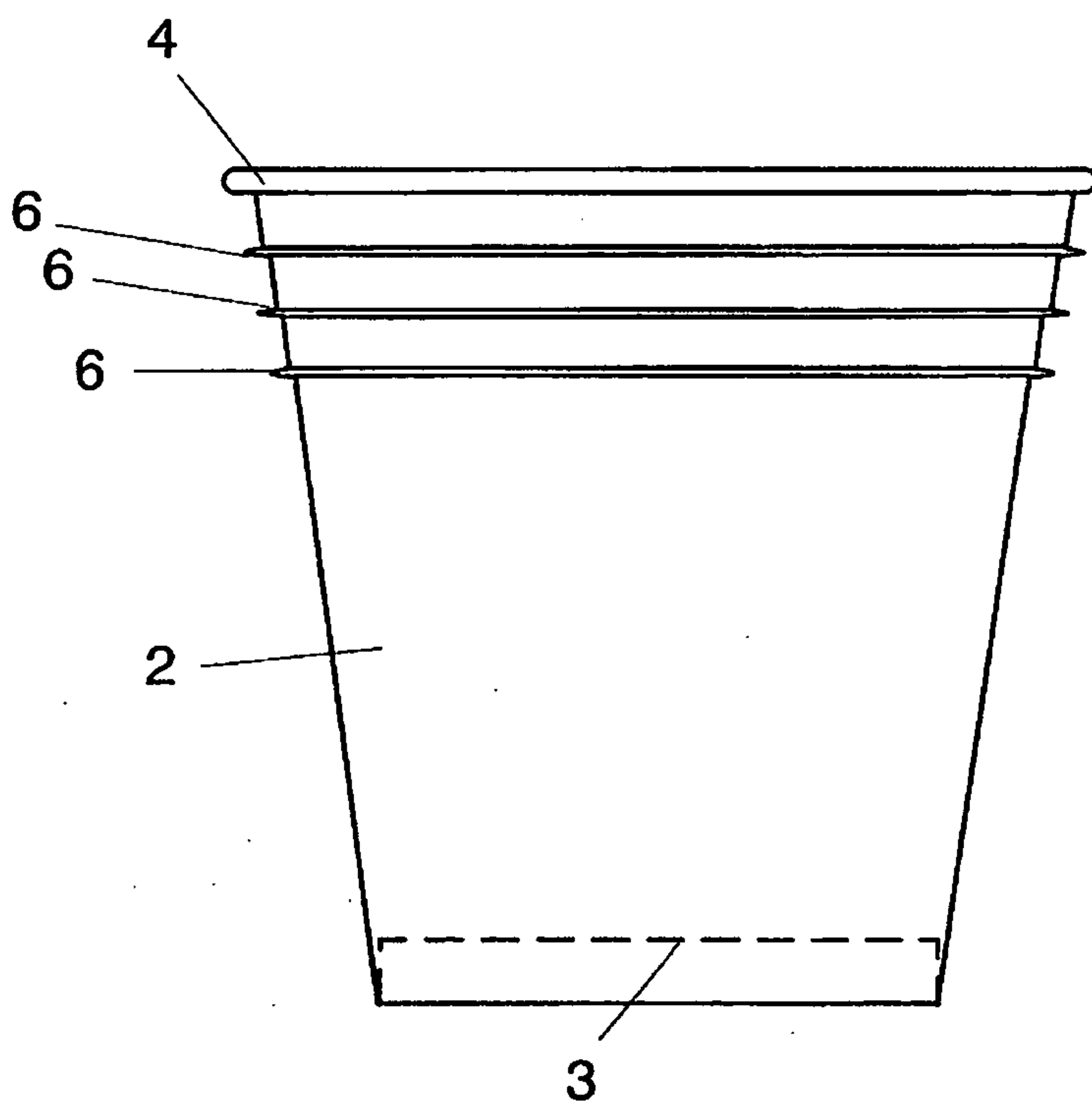

Fig. 2

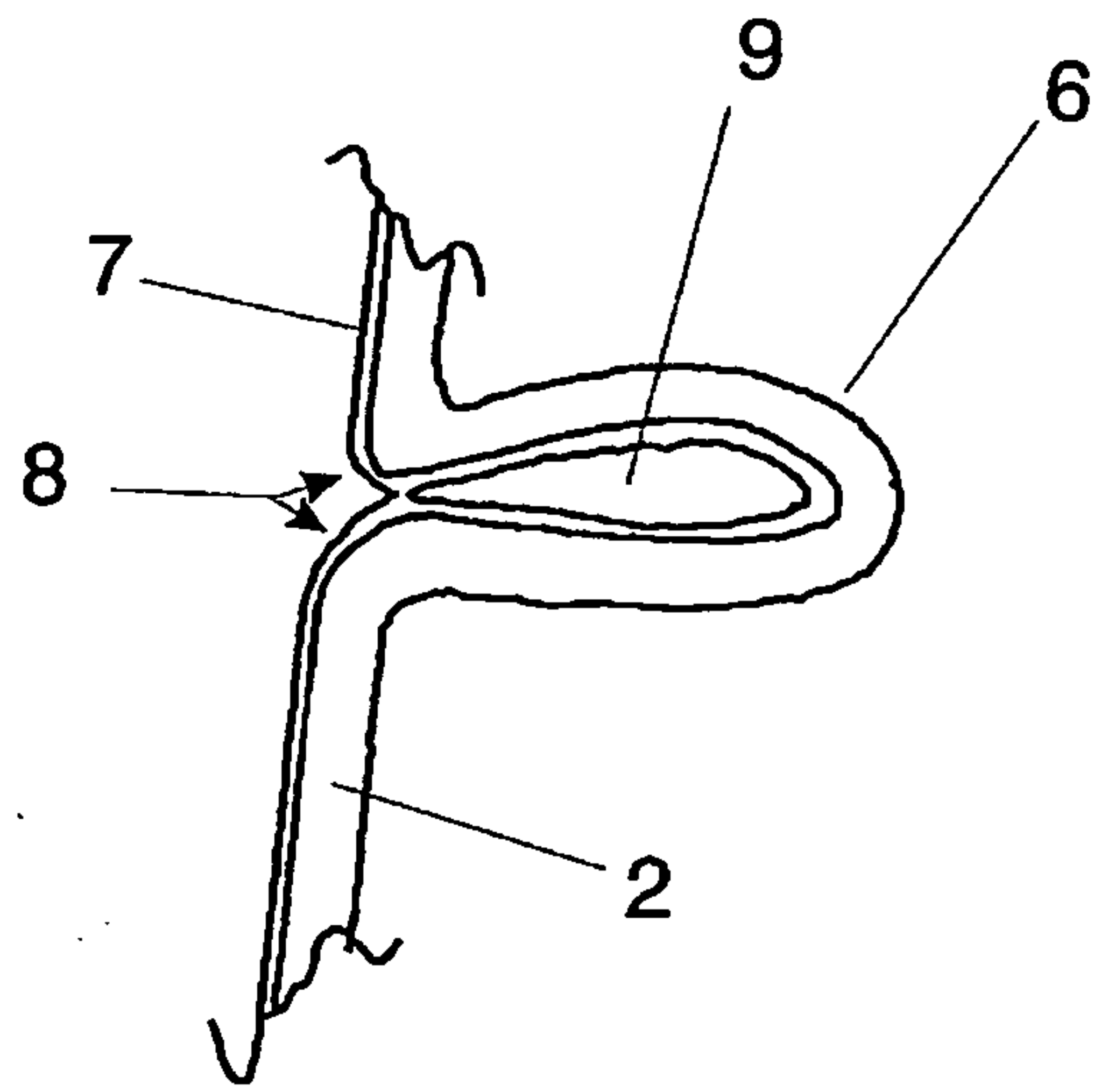

Fig. 3

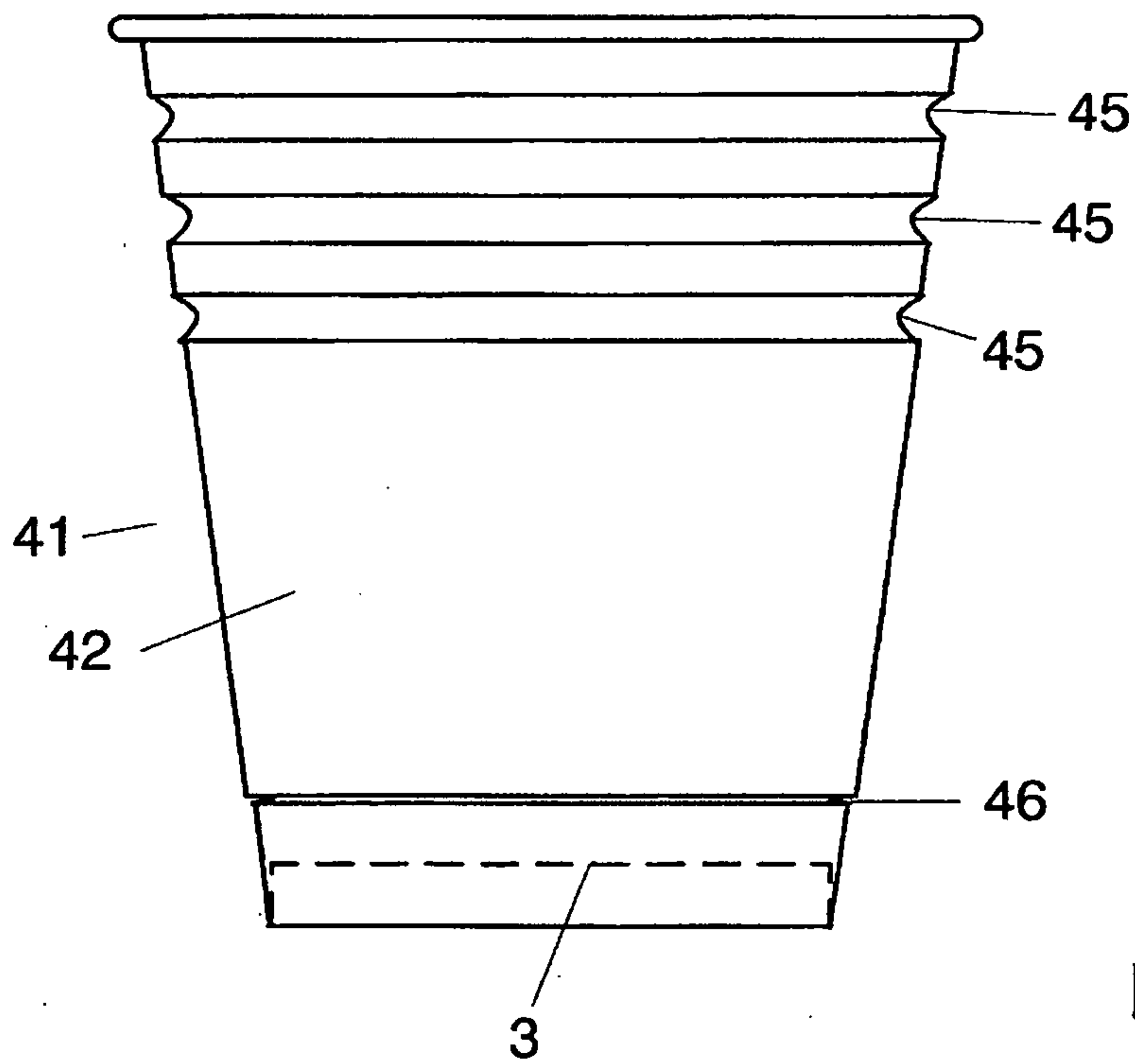
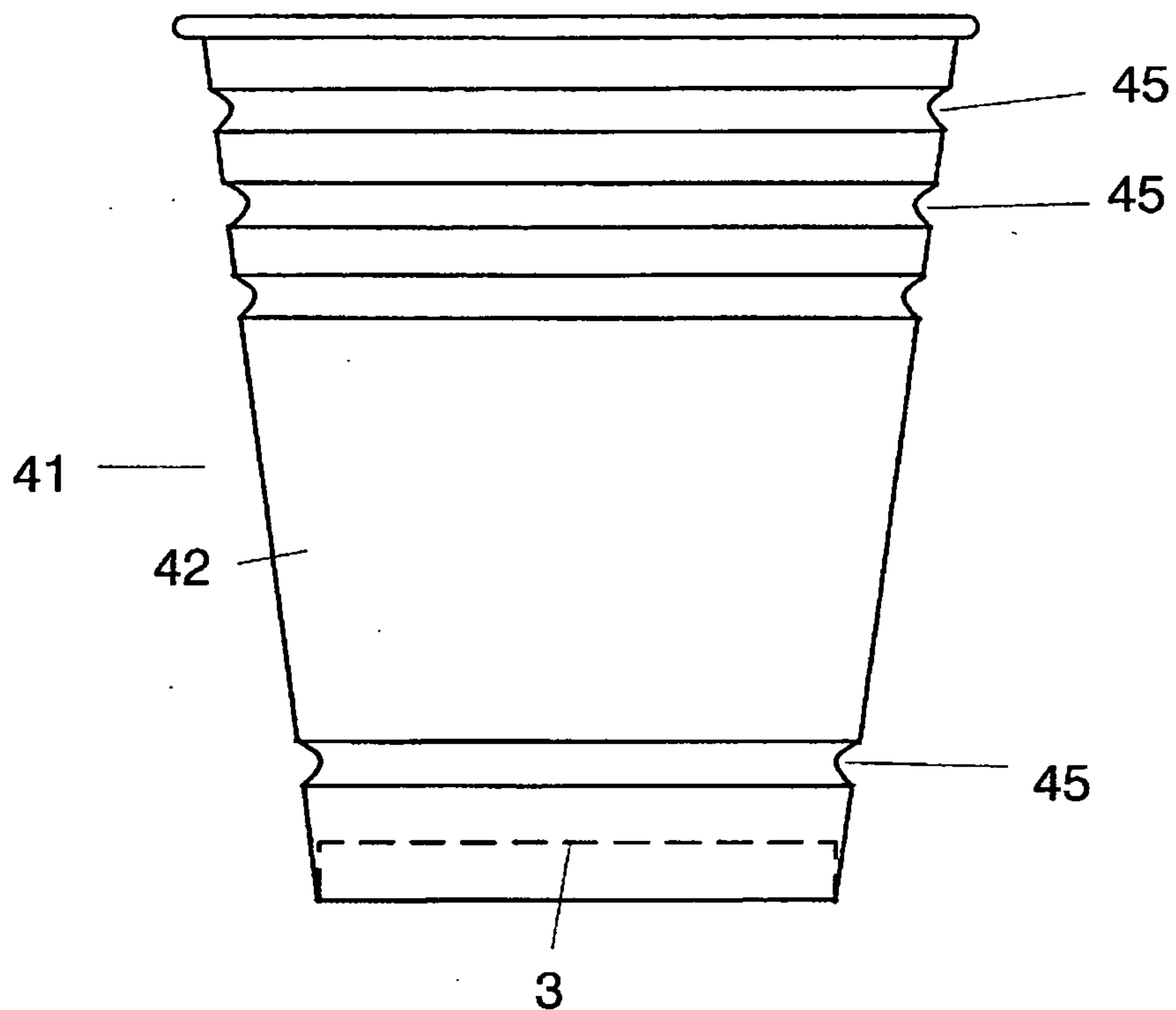

Fig. 4

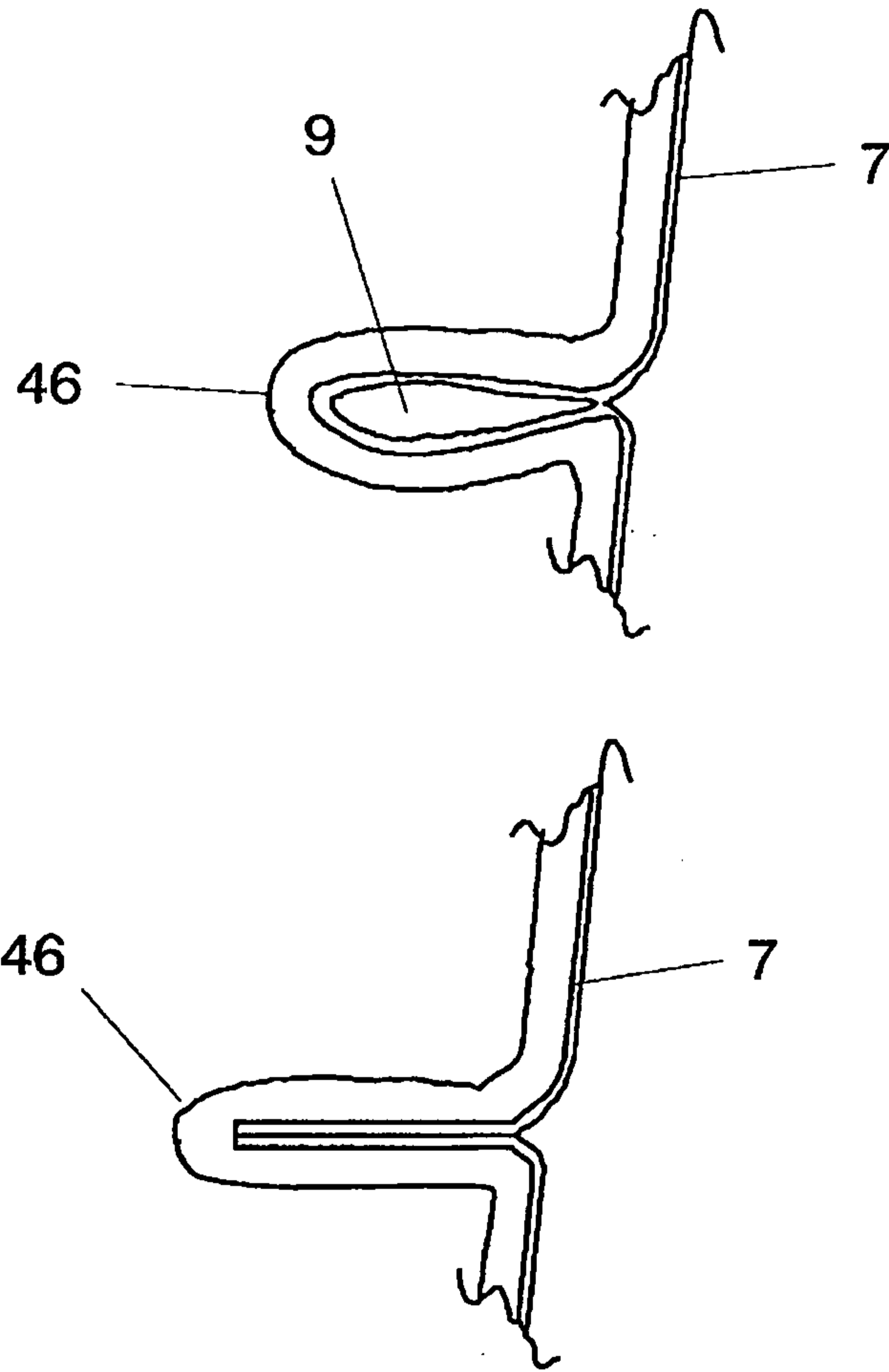
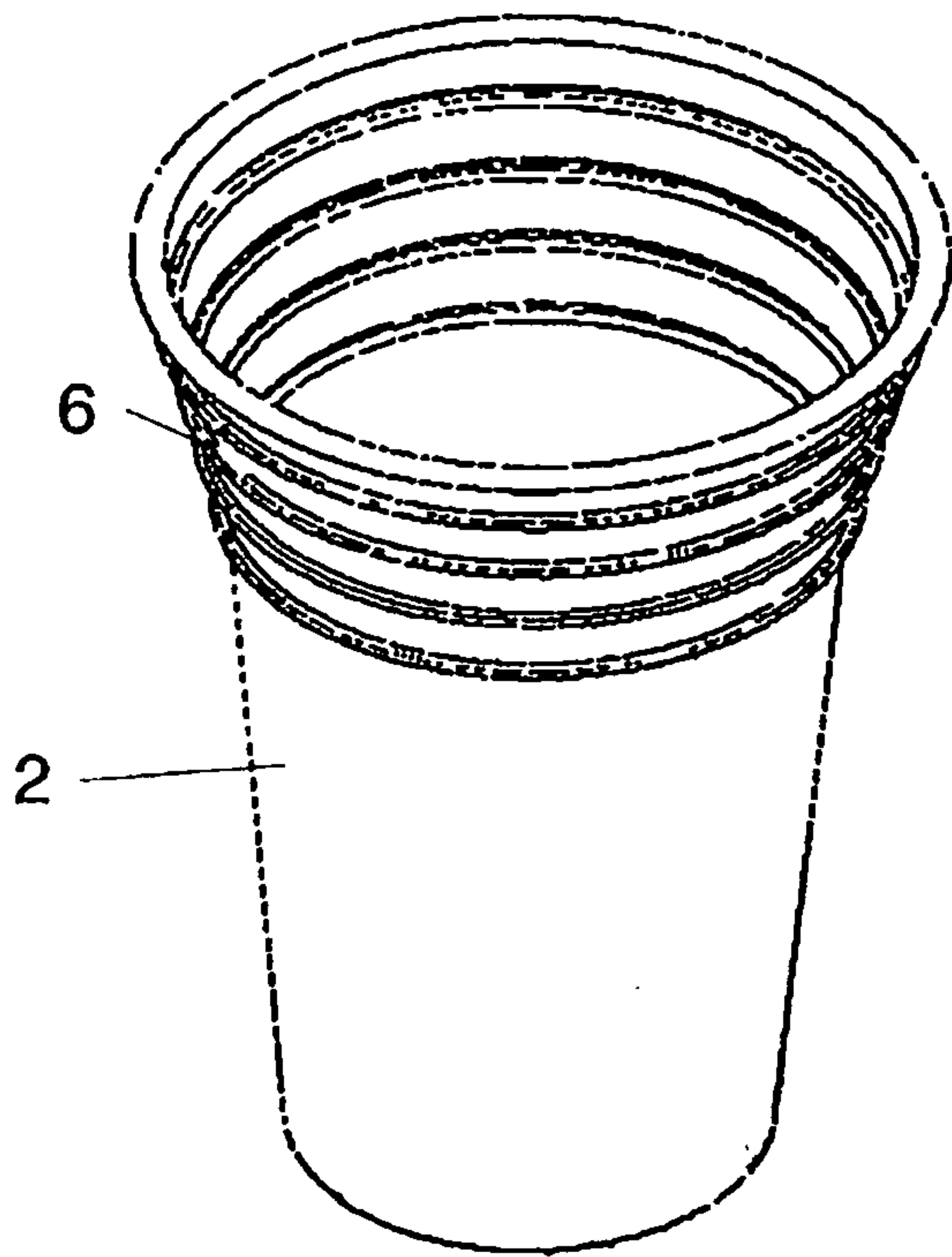

Fig. 5



Fig, 6

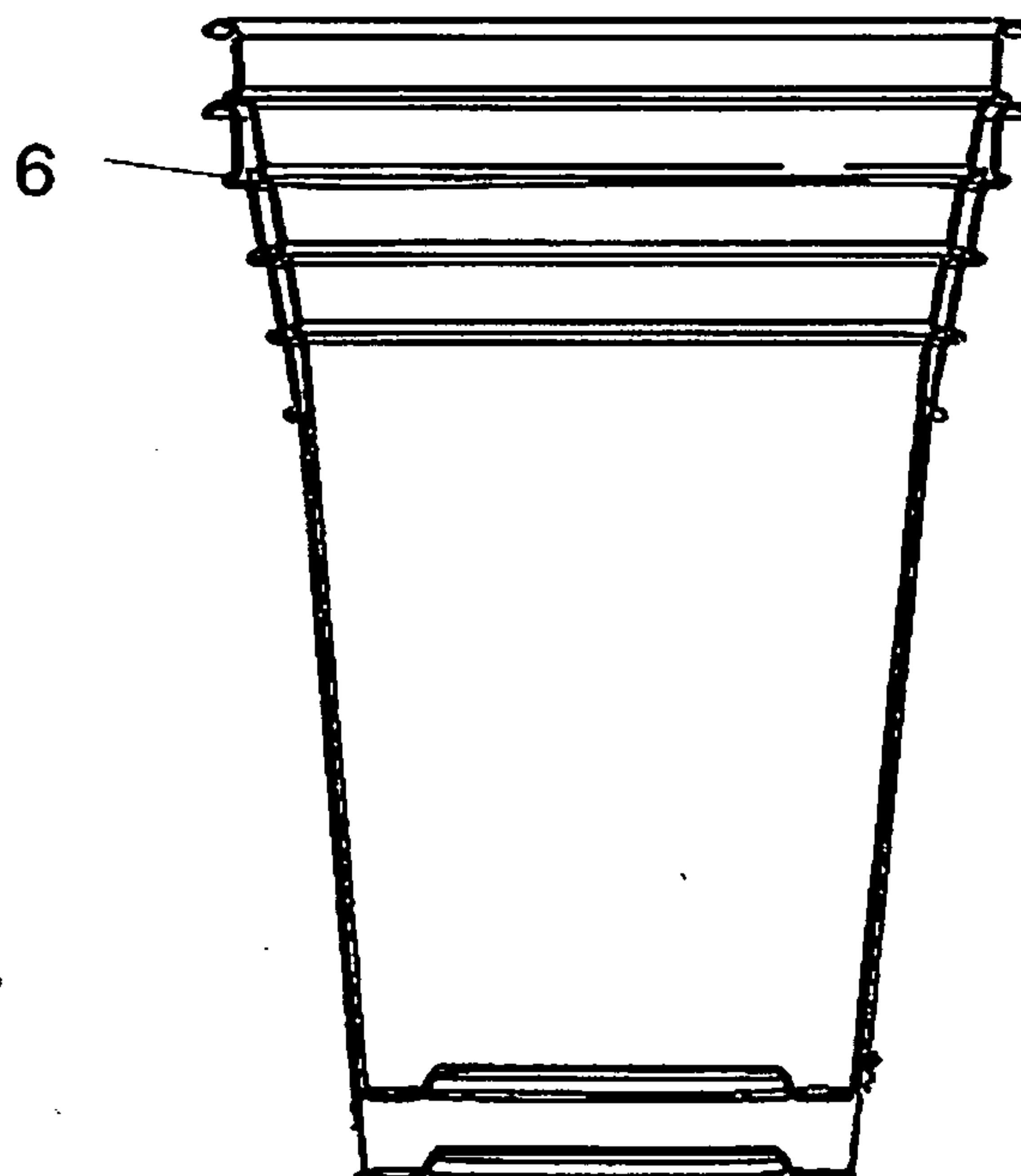

Fig. 7

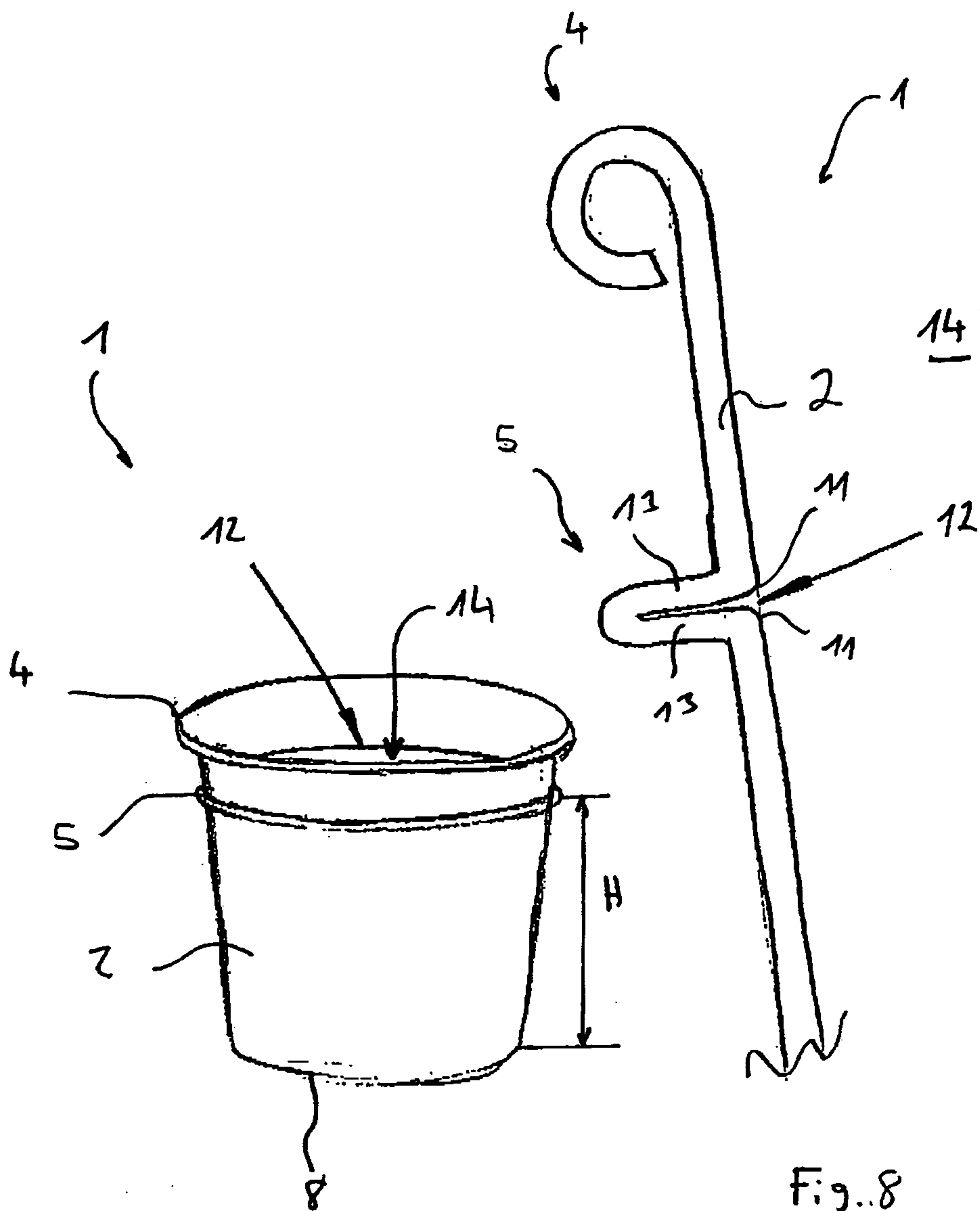

Fig. 8

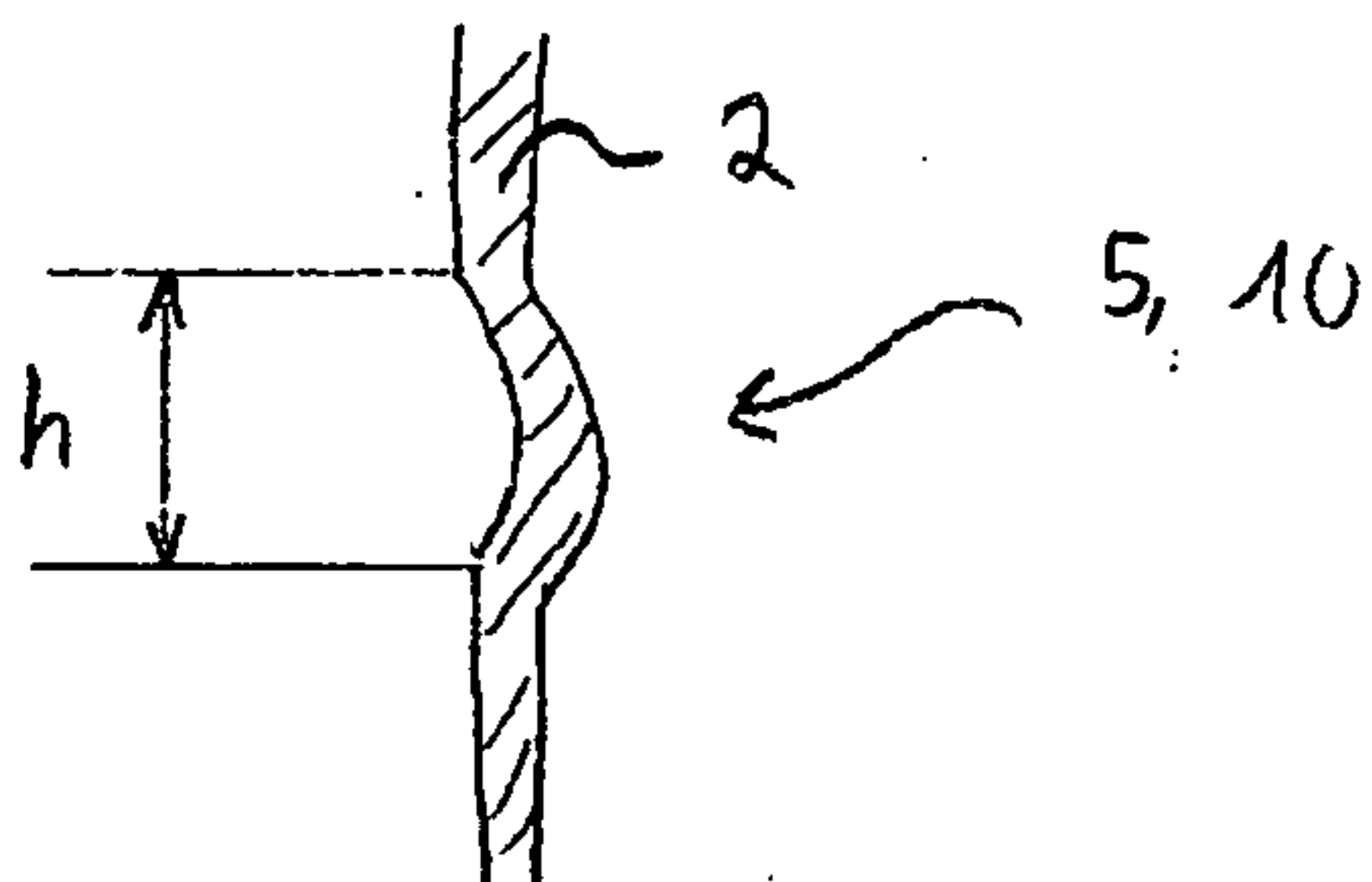

Fig. 9a

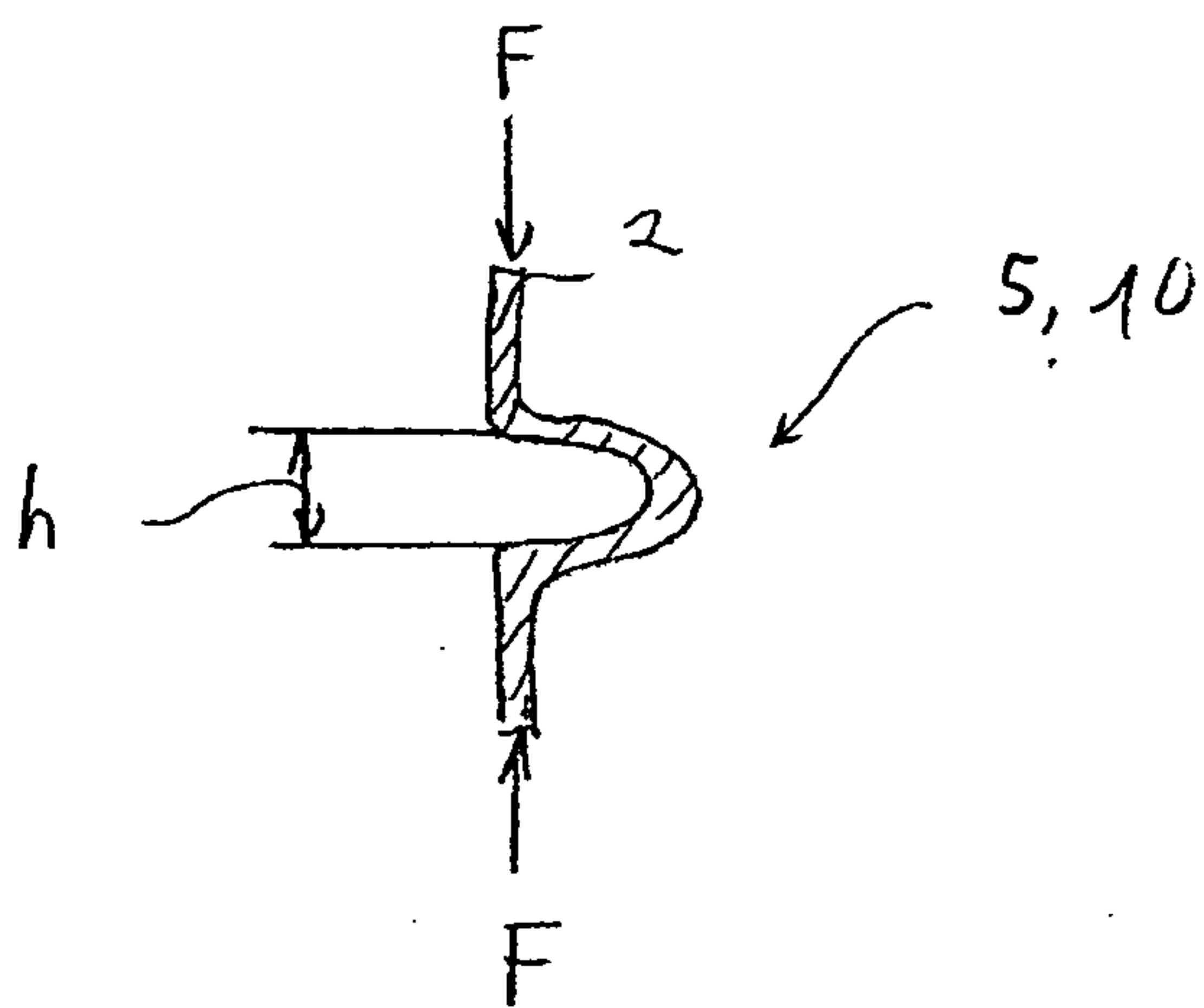

Fig. 9b

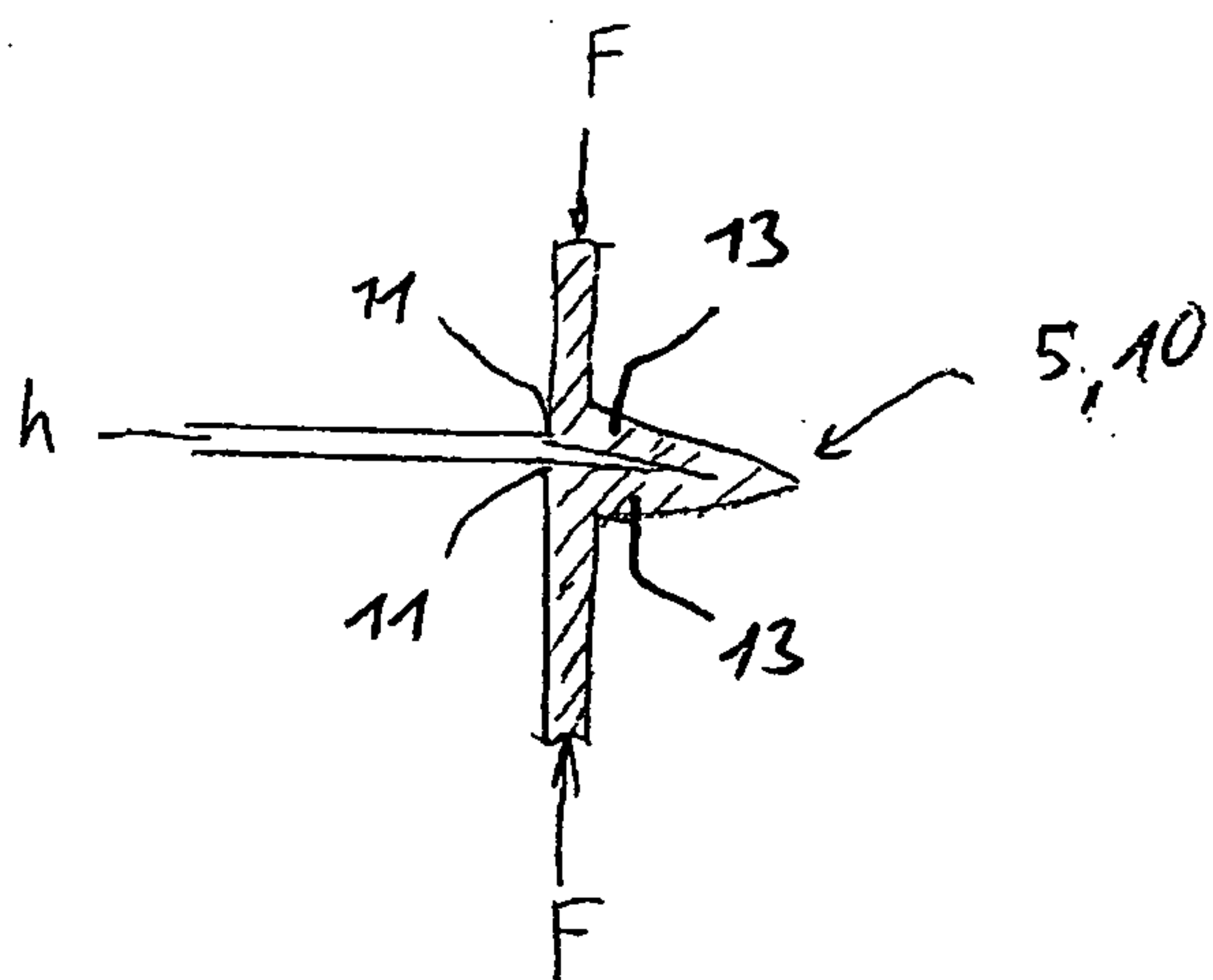

Fig. 9c

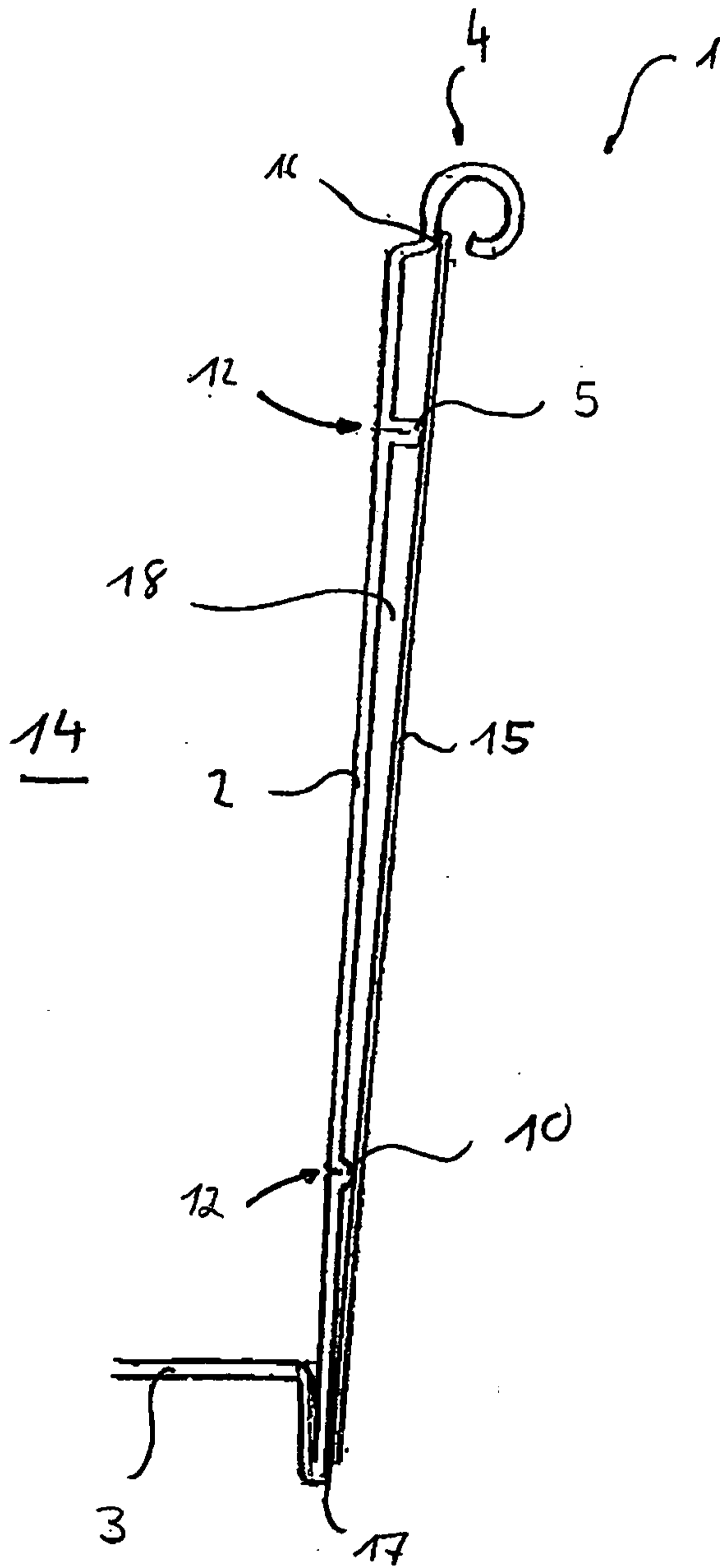

Fig. 10

