



- (51) International Patent Classification: Not classified
- (21) International Application Number: PCT/GB2013/051673
- (22) International Filing Date: 25 June 2013 (25.06.2013)
- (25) Filing Language: English
- (26) Publication Language: English
- (30) Priority Data: 1211304.9 26 June 2012 (26.06.2012) GB
- (72) Inventor; and
- (71) Applicant : CARR, Tony [GB/GB]; 65 Hawthorn Road, Hornsey, London, N8 7LY (GB).
- (74) Agents: ROBEY, James et al.; Wilson Gunn, 5th Floor, Blackfriars House, The Parsonage, Manchester, Lancashire M3 2JA (GB).
- (81) Designated States (unless otherwise indicated, for every kind of national protection available): AE, AG, AL, AM, AO, AT, AU, AZ, BA, BB, BG, BH, BN, BR, BW, BY,

BZ, CA, CH, CL, CN, CO, CR, CU, CZ, DE, DK, DM, DO, DZ, EC, EE, EG, ES, FI, GB, GD, GE, GH, GM, GT, HN, HR, HU, ID, IL, IN, IS, JP, KE, KG, KN, KP, KR, KZ, LA, LC, LK, LR, LS, LT, LU, LY, MA, MD, ME, MG, MK, MN, MW, MX, MY, MZ, NA, NG, NI, NO, NZ, OM, PA, PE, PG, PH, PL, PT, QA, RO, RS, RU, RW, SC, SD, SE, SG, SK, SL, SM, ST, SV, SY, TH, TJ, TM, TN, TR, TT, TZ, UA, UG, US, UZ, VC, VN, ZA, ZM, ZW.

(84) Designated States (unless otherwise indicated, for every kind of regional protection available): ARIPO (BW, GH, GM, KE, LR, LS, MW, MZ, NA, RW, SD, SL, SZ, TZ, UG, ZM, ZW), Eurasian (AM, AZ, BY, KG, KZ, RU, TJ, TM), European (AL, AT, BE, BG, CH, CY, CZ, DE, DK, EE, ES, FI, FR, GB, GR, HR, HU, IE, IS, IT, LT, LU, LV, MC, MK, MT, NL, NO, PL, PT, RO, RS, SE, SI, SK, SM, TR), OAPI (BF, BJ, CF, CG, CI, CM, GA, GN, GQ, GW, KM, ML, MR, NE, SN, TD, TG).

Published: — without international search report and to be republished upon receipt of that report (Rule 48.2(g))

(54) Title: VENTILATION UNITS

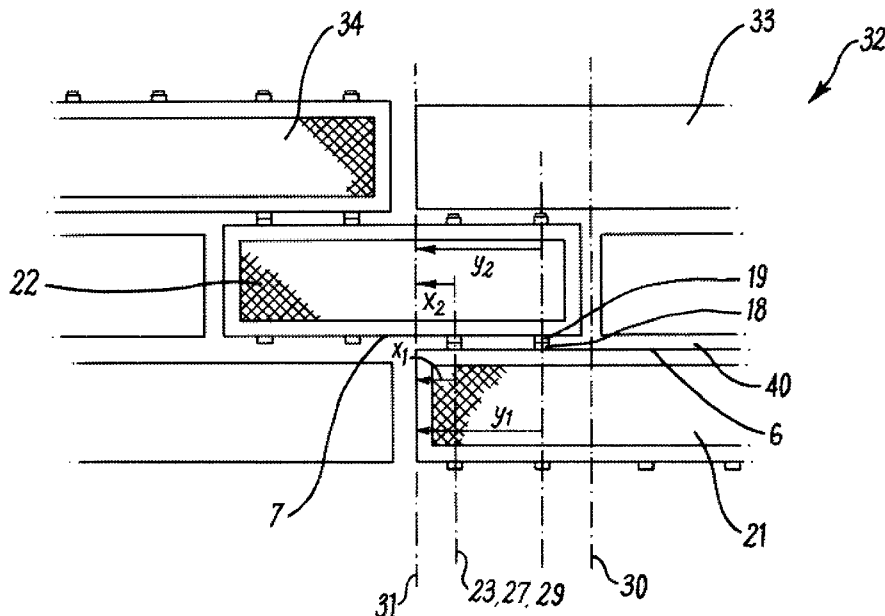

Fig. 11

(57) Abstract: A set of ventilation units comprises a first and second ventilation unit, wherein a surface of the first ventilation unit is provided with at least one formation and a surface of the second ventilation unit is provided with at least one co-operating formation. The formation(s) and co-operating formation(s) is/are engageable with one another in a direction substantially perpendicular to said surface of the first ventilation unit and/or said surface of the second ventilation unit.

WO 2014/001784 A2

VENTILATION UNITS

Technical Field of the Invention

The present invention relates to a ventilation unit such as an airbrick. The present invention also relates to a method of installing such a ventilation unit.

5 Background to the Invention

Buildings, both domestic and commercial, are generally subject to regulations which require that the building has a sufficient level of ventilation.

In order to provide such ventilation, it is known to use one or more ventilation units. One such ventilation unit is an airbrick. An airbrick is used in place of a
10 masonry brick to provide for ventilation through a wall of a building. It has a generally similar external shape as a conventional masonry brick, but is substantially hollow and has front and rear faces that are fluidly connected to each other and open into their external surroundings, thereby allowing ventilation through the airbrick.

The level of ventilation required by a room of a building varies depending on,
15 for example, the size of the room, its number of windows, etc. Accordingly, it is sometimes necessary to use more than one ventilation unit, in a stacked arrangement, in order to provide the required level of ventilation.

It is currently known to provide air-bricks that are stackable in alignment with each other, i.e. so that respective end faces of the airbrick in the stack are aligned (as
20 well as their respective front and rear faces).

Although such a stacking arrangement increases the level of ventilation provided (as compared to with a single ventilation unit), it interrupts with the normal

staggered arrangement of masonry bricks in the wall. This interferes with a builder's typical method of laying bricks, disrupts the structural continuity of the wall and is aesthetically displeasing.

In addition, known stackable ventilation units are engaged with each other by
5 sliding one on top of the other, i.e. where the lower face of a ventilation unit in the stack is slid across the upper face of a ventilation unit adjacently below it in the stack. Such slidable engagement acts to knock cement off adjacent bricks, thereby causing damage to the structural integrity of the wall.

Furthermore, such a ventilation unit is susceptible to being forcibly removed
10 from a wall by sliding it out of the wall, in order to gain access through the wall.

Embodiments of the present invention seek to overcome the above problems.

Summary of the Invention

According to a first aspect of the invention there is provided a set of ventilation units comprising first and second ventilation units, wherein a surface of
15 the first ventilation unit is provided with at least one formation and a surface of the second ventilation unit is provided with at least one co-operating formation, wherein said at least one formation and said at least one co-operating formation are engageable with each other in a direction that is substantially perpendicular to said surface of the first ventilation unit and/or said surface of the second ventilation unit.

20 According to a second aspect of the present invention there is provided a first ventilation unit comprising a first surface provided with at least one formation and a second surface provided with at least one co-operating formation, wherein said at least one formation is engageable with the at least one co-operating formation of a

second said ventilation unit in a direction that is substantially perpendicular to the first surface of the first ventilation unit and/or to the second surface of the second ventilation unit.

This allows the first and second ventilation units to be engaged with each other by moving the first and second ventilation units together in direction that is substantially perpendicular to said surface of the first ventilation unit and/or said surface of the second ventilation unit, until the at least one formation and at least one co-operating formation engage. Accordingly, the ventilation units can be engaged with each other without having to slide one ventilation unit across a surface of the other ventilation unit.

This is advantageous in that it allows the ventilation units to be engaged with each other without causing cement to be knocked off adjacent masonry bricks, thereby avoiding damage to the structural integrity of a wall in which the ventilation units are installed.

Preferably said at least one formation and at least one co-operating formation are disengageable from each other in a direction that is substantially perpendicular to said surface of the first ventilation unit and/or said surface of the second ventilation unit.

This is advantageous in that, since the ventilation units cannot be disengaged from each other by sliding one relative to the other, it is harder to remove the ventilation units, from a wall in which they are installed, by forcibly sliding them out of the wall.

Preferably, the at least one formation and the at least one cooperating formation are arranged such that they are attached to each other when they are engaged. Preferably the at least one formation and at least one cooperating formation are arranged such that when they are engaged, the first and second ventilation units
5 are constrained from relative movement in the length and/or width directions of the ventilation units.

Preferably the at least one formation and the at least one co-operating formation are engageable by a push-fit engagement. Preferably the at least one formation and the at least one co-operating formation are engageable by an
10 interference fit.

The at least one formation and the at least one co-operating formation may be releasably engageable. Preferably the at least one formation and the at least one co-operating formation are permanently engageable.

Preferably the at least one formation protrudes outwardly from said surface of
15 the first ventilation unit in a direction which is substantially perpendicular to said surface. Preferably the at least one formation has a longitudinal axis that is substantially perpendicular to said surface. Preferably the at least one formation is axisymmetric about its longitudinal axis.

Preferably the at least one co-operating formation is arranged to receive said
20 formation in a direction which is substantially perpendicular to said surface of the second ventilation unit. Preferably the at least one co-operating formation comprises a surface that defines a space for receiving the at least one formation and said space has a longitudinal axis that is substantially perpendicular to said surface of the second

ventilation unit. Preferably said surface is arranged to form an interference fit with the at least one formation, when the at least one formation is received within said space. Preferably said space is axisymmetric about its longitudinal axis.

5 Preferably the at least one formation and the at least one co-operating formation are engageable by slidably receiving the at least one formation within said space of the at least one co-operating formation. Preferably, the longitudinal axes of said at least one formation and said space are substantially parallel when the at least one formation is received within said space.

10 Preferably the first ventilation unit is stackable on or against the second ventilation unit. Preferably the first ventilation unit is stackable on or against the second ventilation unit about said surfaces of the first and second ventilation units.

15 Preferably said surfaces of the first and second ventilation units are substantially planar. Preferably said surfaces of the first and second ventilation units are arranged such that, when the at least one formation and the at least one co-operating formations are engaged, said surfaces are adjacent to each other. Preferably, when the at least one formation and the at least one co-operating formations are engaged, said surfaces are opposed to each other. Preferably, when the at least one formation and the at least one co-operating formations are engaged, said surfaces are substantially parallel.

20 Preferably the first and second ventilation units are arranged such that, when the at least one formation and the at least one co-operating formation are engaged, a space is provided between said surfaces. Preferably said space is in a direction which

is substantially perpendicular to said surfaces of the first and second ventilation units. Preferably the space is for receiving an adhesive.

Preferably the at least one formation and/or the at least one co-operating formation is/are provided with a spacer element, which spaces said surfaces from each other when the at least one formation and the at least one co-operating formation are engaged. The spacer element may be formed by, or in part, by the at least one formation and/or the at least one cooperating formation.

Where the at least one cooperating formation comprises a surface that defines a space for receiving the at least one formation, said surface preferably comprises a section which is arranged to act in limiting abutment with the at least one formation when the at least one formation and the at least one cooperating formation are engaged and wherein said section is distanced from said surface of the second ventilation unit in a direction which is substantially perpendicular to the surface of the second ventilation unit.

This is advantageous in that an adhesive, such as cement may be provided in this space, as the ventilation units are engaged. Accordingly, once the adhesive sets, the ventilation units are fixedly secured to each other by the cement (as well as by the engagement of the at least one formation and the at least one co-operating formation). This maintains the structural integrity of the wall, and makes it difficult, if not impossible, to remove the ventilation units from a structure in which they are installed, for example by forcibly sliding the ventilation units out of the structure.

In addition, this allows the at least one formation and the at least one co-operating formation to key into the adhesive layer in the space, thereby increasing the

strength of the bond between the ventilation units, or between a said ventilation unit and a respectively adjacent structural brick.

Preferably the first and second ventilation units are arranged such that, when the at least one formation and the at least one co-operating formation are engaged, 5 respective lengthwise ends of the first and second ventilation units are substantially aligned. In order to provide this arrangement, the at least one formation and the at least one co-operating formation are preferably located substantially the same distance as each other from respective lengthwise ends of the first and second ventilation units respectively. This is advantageous in that it allows for automatic aligning of the first 10 and second ventilation units, in the lengthwise direction, when the at least one formation and the at least one cooperating formation are engaged.

Preferably the first and second ventilation units are arranged such that, when the at least one formation and the at least one co-operating formation are engaged, the first and second ventilation units are staggered in the lengthwise direction. In order to 15 provide this arrangement, the at least one formation and the at least one co-operating formation are preferably provided at different length-wise positions of the first and second ventilation units respectively. This is advantageous in that it allows the first and second ventilation units to be stacked in a staggered arrangement. Therefore, the stacked ventilation units do not interrupt the normal staggered arrangement of bricks 20 as they can be laid like normal masonry bricks. Accordingly the ventilation units do not interfere with a builder's normal method of laying bricks and do not disrupt the structural continuity of the wall.

Preferably the first and second ventilation units are arranged such that when the at least one formation and the at least one co-operating formation are engaged, a lengthwise end of the first ventilation unit is substantially aligned with a perpendicular bisector that passes through the mid-point of the length of the second ventilation unit, or vice versa. In order to provide this arrangement, preferably the at least one formation is distanced from a lengthwise end of the first ventilation unit by substantially the same amount as the at least one co-operating formation is distanced from a perpendicular bisector that passes through the mid-point of the length of the second ventilation unit. This is advantageous in that it allows the ventilation units to be staggered such that they overlap by half their lengths, which corresponds to the staggered arrangement of masonry bricks.

Preferably the at least one cooperating formation comprises first and second said cooperating formations, said first co-operating formation is at a corresponding position along the length of the second ventilation unit as the at least one formation of the first ventilation unit is along the length of the first ventilation unit and said second co-operating formation is spaced from the first co-operating formation in the length direction of the second ventilation unit. This is advantageous in that the first and second ventilation units can be stacked in both an aligned arrangement, in which the first co-operating formation of the second ventilation unit is engaged with the at least one formation of the first ventilation unit and in a staggered arrangement, in which the second co-operating formation of the second ventilation unit is engaged with the at least one formation of the first ventilation unit. Accordingly, this provides the above advantages of an aligned and a staggered arrangement of ventilation units, as required.

Preferably the first and second ventilation units are arranged such that, when the at least one formation and co-operating formation are engaged, width-wise ends of the first and second ventilation units are substantially aligned.

Preferably the at least one formation comprises a plurality of said formations
5 and said formations are provided at different lengthwise positions on said surface of the first ventilation unit. Preferably the at least one cooperating formation comprises a plurality of said cooperating formations and said formations are provided at different lengthwise positions on said surface of the second ventilation unit. Preferably
10 formations and cooperating formations provided at different lengthwise positions are engageable with each other. Preferably formations and cooperating formations provided at corresponding lengthwise positions are engageable with each other.

Preferably the first and/or second ventilation units each comprise an inlet fluidly connected to an outlet. Preferably the first and/or second ventilation unit comprises at least one surface which defines a space and said inlet is fluidly
15 connected through the space to said outlet. Preferably the inlet and outlet are respectively provided on outer and inner faces of the ventilation unit, or vice versa.

Preferably the first and/or second ventilation unit is for providing ventilation through a structure of a building. Preferably the first and/or second ventilation unit is an airbrick. Preferably the first and/or second ventilation unit has substantially the
20 same external dimensions as a structural brick.

Preferably the first and/or second ventilation unit is elongate. Preferably each ventilation unit has the general shape of a cuboid.

Preferably the first and second ventilation units are substantially identical.

The set of ventilation units may contain more than two said ventilation units.

According to a third aspect of the present invention there is provided a method of stacking a set of ventilation units according to the first aspect of the invention comprising providing said first and second ventilation units, stacking the first
5 ventilation unit on the second ventilation unit and engaging the at least one cooperating formation of the second ventilation unit with the at least one formation of the ventilation unit in a direction that is substantially perpendicular to said surface of the first ventilation unit and/or said surface of the second ventilation unit.

According to a fourth aspect of the invention there is provided a method of
10 installing a set of ventilation units according to the first aspect of the invention in a structure of a building, comprising laying a first row of structural bricks and providing the first ventilation unit in said first row, laying a second row of structural bricks adjacent or on said first row, providing the second ventilation unit in said second row and engaging the at least one cooperating formation of the second ventilation unit
15 with the at least one formation of the first ventilation unit in a direction that is substantially perpendicular to said surface of the first ventilation unit and/or said surface of the second ventilation unit.

Preferably, where the first and second ventilation units are arranged such that, when the at least one formation and the at least one co-operating formation are
20 engaged, the first and second air-bricks are staggered in the lengthwise direction, the first and second ventilation units are staggered in the lengthwise direction.

Preferably, where the first and second ventilation units are arranged such that, when the at least one formation and the at least one co-operating formation are

engaged, the first and second air-bricks are aligned in the lengthwise direction, the first and second ventilation units are aligned in the lengthwise direction.

Preferably the method comprises the step of providing a layer of adhesive material between the first and second ventilation units.

- 5 All of the features described herein may be combined with any of the above aspects, in any combination.

Detailed Description of the Invention

For a better understanding of the invention, and to show how embodiments of the same may be carried into effect, reference will now be made, by way of example,
10 to the accompanying diagrammatic drawings in which:

- Figure 1** shows a perspective view of a ventilation unit according to the present invention, with a screen of the ventilation unit shown in a partially detached position, for illustrative purposes;
- Figure 2** shows a front elevational view of the ventilation unit of Figure 1,
15 with the screen of the ventilation unit omitted for illustrative purposes;
- Figure 3** shows a plan elevational view of the ventilation unit of Figure 2;
- Figure 4** shows an underplan elevational view of the ventilation unit of Figure 2;
- 20 **Figure 5** shows an end view of the ventilation unit of Figure 1, with the screen of the ventilation unit shown in a detached position, for illustrative purposes;

- Figure 6** shows a cross sectional view of a region of a first surface of a first ventilation unit of the preceding figures with a formation taken along the line A-A in Figure 3 and a corresponding cross sectional view of a region of second surface of a second ventilation unit of the preceding figures, with a cooperating formation taken along the line B-B in Figure 4, where the formation of the first ventilation unit and cooperating formation of the second ventilation unit are positioned prior to engagement;
- 5
- Figure 7** shows a corresponding view to that of Figure 6, but where the formation and cooperating formation are positioned in engagement with each other;
- 10
- Figure 8** shows a plan elevational view of one of the formations of the ventilation unit of Figures 1 to 6;
- Figure 9** shows an underplan view of one of the cooperating formations of the ventilation unit of Figures 1 to 6;
- 15
- Figure 10** shows a perspective view of an exterior side of a wall comprising a set of ventilation units according to the present invention, arranged in a first lengthwise staggered arrangement;
- Figure 11** shows a front elevational view of an interior side of a region of the wall of Figure 10 that comprises the ventilation units;
- 20
- Figure 12** shows a corresponding view to that of Figure 11, but with the ventilation units in a second lengthwise staggered arrangement, and
- Figure 13** shows a corresponding view to that of Figures 11 and 12, but with the ventilation units in an aligned arrangement.

In the following the terms upper, lower, side and the like terms are used for convenience and refer to the ventilation unit(s) as shown oriented in the drawings, the orientation in which it/they is/are intended to be used, and should not be taken as otherwise limiting.

5 Referring to Figures 1 to 5 there is shown a ventilation unit in the form of an airbrick 1. The airbrick 1 is for location in a structure of a building, such as a wall, floor or roof of a building, to providing ventilation through the structure.

The airbrick 1 comprises a body 2 and a screen 3. The airbrick body 2 has a generally cuboidal shape formed by opposed inner and outer faces 4, 5, opposed first
10 and second surfaces 6, 7 and opposed end surfaces 8, 9. The airbrick body 2 has a longitudinal axis 10.

The airbrick has substantially similar external dimensions to a conventional structural, e.g. masonry, brick and is for use, in a structure, in place of a structural brick.

15 Although in the current embodiment the airbrick body has a generally cuboidal shape, it will be appreciated that an airbrick body having different shapes may fall within the scope of the present invention, for example it may have the shape of a regular cube, etc.

The inner and outer faces 4, 5, of the airbrick body 2 are substantially open.
20 The longer edges of the inner face 4 are joined to respectively opposed longer edges of the outer face 5 by the first and second surfaces 6, 7 respectively.

The shorter edges of the inner face 4 are joined to the opposed shorter edges of the outer face 5 by the end surfaces 8, 9 respectively.

The airbrick body 2 comprises an air-inlet fluidly connected to an air-outlet 12. The air-inlet 11 and air-outlet 12 are formed by the open outer and inner faces 5, 4 of the airbrick body 2 respectively (or vice-versa). The air-inlet 11 is fluidly connected to the air-outlet 12 by the body 2 of the air-brick 1.

5 The screen 3 is attachable to the outer face 5 of the airbrick body 2 so as to cover the air-inlet 11 of the air-brick 2. The screen 3 comprises a stainless steel mesh 13 housed within a generally rectangular plastic frame 14 that is sized and dimensioned so as to form a close fit over the open outer face 5 of the airbrick body 2. It will be appreciated that the screen 3 may alternatively, or additionally, cover the
10 inner face 4 of the airbrick body 2 so as to cover the air-outlet 12 of the air-brick 1.

The screen 3 is releasably attachable to the airbrick body 2. In the current embodiment a tongue and groove arrangement is used with a pair of tongues 15 disposed along upper and lower ends of on an inner surface of the frame 14 of the screen 3 and cooperating grooves 16 disposed along upper and lower ends of the outer
15 face 5 of the airbrick body 2. However, it will be appreciated that the reciprocal arrangement may be used, i.e. with the tongues 15 provide on the airbrick body 2 and the grooves 16 provided on the screen 3. In addition, it will be appreciated that any other suitable form of attachment of the screen 3 to the airbrick body 2 may be used.

When the screen 3 is attached to the air-brick body 2, it covers the air-inlet 11,
20 thereby preventing vermin, such as rats, mice, slugs and birds from passing through the air inlet 11.

The airbrick body 2 is provided with internal webs 17, in order to provide strength and rigidity, while allowing ventilation through the airbrick body 2.

A plurality of formations 18 is disposed on the first surface 6 of the airbrick body 2. The formations 18 are uniformly distributed across the length and width of said first surface 6. A plurality of co-operating formations 19 is disposed on the second surface 7 of the airbrick body 2. The co-operating formations 19 are uniformly distributed across the length and width of the second surface 7, at corresponding spatial positions to those of the formations on the first surface 6.

The formations and cooperating formations 18, 19 are arranged in a generally rectangular array, with rows of the array extending in the length direction of the respective first and second surfaces 6, 7 and columns of the array extending in the width direction. The formations and cooperating formations 18, 19 in each row and column are uniformly spaced in said length and width directions respectively.

In the current embodiment the formations and cooperating formations 18, 19 are arranged in two rows and four columns. Accordingly, each row comprises four formations or cooperating formations 18, 19 distributed in the length direction of the respective surface. Each column comprises two formations or cooperating formations 18, 19 distributed in the width direction of the respective surface. However, it will be appreciated that different numbers of formations/cooperating formations 18, 19 in the length and width directions may be used. Furthermore, it is envisaged that the first and second surfaces could be provided with a single formation and co-operating formation respectively.

Reference will now be made to Figures 6 and 7 which both show a cross sectional view of a region of first surface 6 and a formation 18 of a first said airbrick 21 taken along the line A-A in Figure 3 and a corresponding cross sectional view of a

region of second surface of a second said airbrick 22 and a cooperating formation 19 taken along the line B-B in Figure 4. The first and second airbricks 21, 22 are substantially identical to the above described airbrick 1. Accordingly, the first and second airbricks 21, 22 have substantially the same dimensions, including substantially the same width, length and depth. In Figure 6, the formation 18 of the first airbrick 21 and cooperating formation 19 of the second airbrick 22 are positioned prior to engagement. In Figure 7, the formation 18 and cooperating formation 19 are engaged with each other.

The formations 18 on the first surface 6 of the first airbrick 21 are engageable with the co-operating formations 19 on the second surface of a second said airbrick 22 in a direction that is substantially perpendicular to the first surface of the first airbrick and the second surface of the second airbrick. Similarly, the cooperating formations 19 on the second surface of the first airbrick 21 are engageable with the formations 18 on the first surface 6 of the second airbrick 22 in a direction that is substantially perpendicular to the first surface of the second airbrick and the second surface of the first airbrick (see below).

Each formation 18 comprises a generally elongate protrusion in the form of a generally cylindrical body that protrudes outwardly from the first surface 6 of the airbrick and has a longitudinal axis 23 which is substantially perpendicular to said first surface. The body has a step decrease in its radius along its length so as to form first and second sections 24, 25, with the first section 24 being of greater radius than the second section 25. The first and second sections 24, 25 are proximal and distal to the first surface 6 of the airbrick body 2 respectively.

It will be appreciated that the body of the formations 18 may form different shapes. For example, the body of the formations 18 may have a cross-sectional shape which is substantially square, triangular, diamond shaped, etc.

Each co-operating formation 19 comprises a generally cylindrical body 26
5 having a longitudinal axis 27 that is substantially perpendicular to the second surface
7.

An end of the body 26 of the co-operating formation 19 that is distal to the
second surface 7 of the airbrick body 2 is provided with a recess such that an inner
wall of the recessed portion of the body 26 defines a space 28. The recessed space 28
10 is generally cylindrical and has a longitudinal axis 29 that is substantially co-incident
and substantially parallel to the longitudinal axis 27 of the body 26 of the co-operating
formation 19. The longitudinal axis 29 of the recess 28 is substantially perpendicular
to the second surface 7 of the airbrick body 2.

The recess 28 is sized and dimensioned to receive the second section 25 of the
15 formation 18 such that an interference fit is formed between the second section 25 of
the formation 18 an inner surface of the body 26 of the cooperating formation 19.

It will be appreciated that, in an alternative arrangement, the formations 18
may be provided on the second surface 7 of the airbrick body 2 and the cooperating
formations 19 provided on the first surface of the airbrick body 2.

20 In order to engage the formation 18 and cooperating formation 19, they are
moved from the position shown in Figure 6, to the position shown in Figure 7.
Specifically, the longitudinal axis 23 of the body of the formation 18 is aligned with
the longitudinal axis 29 of the recess 28 of the cooperating formation 19. The second

section 25 of the body of the formation 18 is then slidably inserted into the recess 28, in a direction that is substantially parallel to the respective longitudinal axes 23, 29 of the body and recess, until the respective distal ends of the first section 24 of the body of the formation and of the body 26 of the cooperating formation 19 abut each other.

5 At this point, an interference fit is formed between the second section 25 of the formation 18 and the inner surface of the body 26 of the cooperating formation 19.

When the formations 18 and cooperating formations 19 are engaged, the first and second airbricks are fixedly attached to each other. Accordingly they are prevented from relative movement in the length and width directions.

10 By virtue of the interference fit, the formations and cooperating formations are releasably attached to each other. It will, of course, be appreciated that an arrangement whereby the formations and cooperating formations are permanently attached is also envisaged.

15 Accordingly, the formation and cooperating formation 18, 19 are engageable in a direction that is substantially perpendicular to the first surface 6 of the first airbrick 21 and the second surface 7 of the second airbrick 22.

Therefore, the first and second airbricks 21, 22 can be engaged with each other without having to slide one airbrick across the first or second surface of the other airbrick.

20 This allows the airbricks 21, 22 to be engaged with each other without causing cement to be knocked off the airbricks 21, 22 or off adjacent masonry bricks in a building structure, e.g. a wall, in which the airbricks are installed (see below), thereby avoiding damage to the structural integrity of the structure. In addition, since the

airbricks 21, 22 cannot be disengaged from each other by sliding one relative to the other it is difficult, if not impossible, to remove the airbricks from the structure by forcibly sliding them out of the structure.

It will be appreciated that, where the first surface 6 of the first said airbrick 21 is not substantially parallel to the second surface 7 of the second said airbrick 22 when the formations 18 of the first airbrick 21 are engaged with the cooperating formations 19 of the second airbrick 22, the formations and co-operating formations 18, 19 may be engageable in a direction that is substantially perpendicular to the first surface 6 of the first airbrick 21 and/or the second surface 7 of the second airbrick 22.

As can be seen from Figure 7, when a formation 18 on the first surface 6 of the first airbrick 21 is engaged with the cooperating formation 19 of the second surface 7 of the second airbrick 22, the first and second surfaces 6, 7 are spaced from each other, in a direction substantially perpendicular to said surfaces, by the combined length of the first section 24 of the body of the formation 18 and the body 26 of the co-operating formation 19.

This is advantageous in that cement may be provided in this space, before the formation and cooperating formations 18, 19 are engaged, i.e. before the first airbrick 21 is laid on the second airbrick 22. Accordingly, once the cement sets, the first and second airbricks 21, 22 are fixedly secured to each other by the cement (as well as by the engagement of the formations and co-operating formations 18, 19). This maintains the structural integrity of the wall, and makes it even more difficult, if not impossible, to remove the airbricks 21, 22 from the wall, for example by forcibly sliding the airbricks 21, 22 out of the wall.

In addition, this allows the formation and co-operating formation 18, 19 to key into the cement in said space, thereby increasing the strength of the bond between the first and second airbricks 21, 22, or between the airbricks 21, 22 and a respectively adjacent masonry brick (see below).

5 As stated above, the formations and co-operating formations 18, 19 of the first and second airbricks 21, 22 are provided at corresponding positions along the length of the respective surfaces of the airbricks 21, 22. In this respect, corresponding columns of formations and cooperating formations are located substantially the same distance as each other from the lengthwise ends of the respective first and second
10 surfaces 6, 7 of the first and second airbricks 21, 22, i.e. from the ends of the airbrick that terminate in said end faces 8, 9.

The columns of formations 18 on the first surface 6 of the first airbrick 21 and of the cooperating formations 19 on the second surface of the second airbrick that are provided at substantially the same lengthwise positions on the respective airbricks are
15 engageable. Accordingly the first and second airbricks 21, 22 can be engaged in lengthwise alignment with each other by engaging formations of the first airbrick with cooperating formations of the second airbrick that are at substantially the same lengthwise positions on the airbricks 21, 22.

Accordingly when the columns of formations 18 and cooperating formations
20 19 at corresponding lengthwise positions are engaged, the respective lengthwise ends of the airbricks 21, 22 are automatically aligned. This is advantageous in that it allows for automatic aligning of the first and second airbricks 21, 22, in the lengthwise direction, when the airbricks 21, 22 are engaged with other in this way.

Similarly, rows of formations 18 and co-operating formations 19 of the first and second airbricks 21, 22 are provided at corresponding positions along the width of the respective surfaces 6, 7 of the airbricks 21, 22. In this respect, corresponding rows of formations 18 and cooperating formations 19 are located substantially the same distance as each other from the width-wise ends of the respective first and second surfaces 6, 7 of the first and second airbricks 18, 19, i.e. from the ends of the airbricks 21, 22 that terminate in said inner and outer faces 4, 5.

The rows of formations 18 on the first surface 6 of the first airbrick 21 and the rows of cooperating formations 19 on the second surface 7 of the second airbrick 22 that are provided at substantially the same width-wise positions on the respective surfaces are engageable with one another. This is advantageous in that it allows for automatic aligning of the first and second airbricks 21, 22, in the width-wise direction, when they are engaged with each other in this way.

The columns of formations 18 on the first surface 6 of the first airbrick 21 and of the cooperating formations 19 on the second surface 7 of the second airbrick 22, that are provided at different lengthwise positions on the respective surfaces 6, 7 of the airbricks 21, 22 are also engageable. Accordingly the first and second airbricks 21, 22 can be engaged with each other in different relative lengthwise positions by engaging formations of the first airbrick with cooperating formations of the second airbrick that are at different lengthwise positions on the airbrick. Therefore the first and second airbricks can be engaged with each other different staggered lengthwise arrangements, i.e. with their lengthwise ends not in alignment.

Being able to stack the first and second airbricks 21, 22 in a staggered lengthwise arrangement is advantageous in that the stacked airbricks 21, 22 do not interrupt the normal staggered arrangement of masonry bricks in a building structure, such as a wall, as they can be staggered in substantially the same way as
5 normal masonry bricks (see below). Accordingly the airbricks 21, 22 do not interfere with a builder's normal method of laying bricks and do not disrupt the structural continuity of the structure.

Referring now to Figures 10 and 11, there is shown a building structure, in the form of a wall 32, comprising a set of the above described airbricks 1, installed within
10 the wall 32. The wall 32 comprises a plurality of rows of masonry bricks 33 laid one on top of the other, to form a substantially vertical wall. The set of airbricks comprises first, second and third said airbricks 21, 22, 34.

When installed in a structure, such as a wall 32, the first and second surfaces 6, 7 of each airbrick 21, 22, 34 are respectively adjacent and opposed to the second
15 and first faces 7, 6 of airbricks 21, 22, 34, or masonry bricks 33, that are provided in adjacent rows in the structure and that overlap the airbrick 21, 22, 34 in the length direction of the airbrick 21, 22, 34.

For example, where the wall 32 is a substantially vertical wall, as in the current embodiment, the first and second faces 6, 7 of the airbricks 21, 22, 34 form
20 substantially horizontal upper and lower surfaces respectively. It will be appreciated that where the inclination of the wall is different (e.g. substantially horizontal), the orientation of the first and second surfaces 6, 7 will vary accordingly.

The inner and outer faces 4, 5 of the airbrick are exposed to interior and exterior sides of the structure 32, or vice versa. For example, where the airbrick 21, 22, 34 is installed in a wall, as in the current embodiment, to provide ventilation through the wall, the inner face 4 of the airbrick 21, 22, 34 is exposed to the interior of a room defined by the wall 32 and the outer face 5 of the airbrick 21, 22, 34 is exposed to the exterior of the room, or vice versa.

The end surfaces 8, 9 of the airbricks 21, 22, 34 are adjacent and opposed to corresponding end surfaces 8, 9 of adjacent airbricks 21, 22, 34, or masonry bricks 33, in the same row in the structure.

With reference to Figure 11, the longitudinal axes 23 of the formations 18 provided on either side of the midpoint 30 of the length of the first surface 6 of the first airbrick 21 are distanced (x_1, y_1) from the lengthwise end of the first surface 6 on the same respective side of said midpoint 30 by substantially the same amount as the longitudinal axes 29 of the co-operating formations 19 on a correspondingly opposite side of the midpoint of the length of the second surface 7 of the second airbrick 22 are distanced (x_2, y_2) from a perpendicular bisector 31 that passes through the mid-point of the length of the second surface 7. This is advantageous in that it allows the engaged airbricks 21, 22 to be staggered in a lengthwise direction such that they overlap by substantially half their lengths, which corresponds to the typical staggered arrangement of masonry bricks. This arrangement is substantially the same for other airbricks 21, 22, 34 in the set.

Since the airbricks can be staggered and/or aligned with each other, when engaged, this allows the airbricks to be stacked in a large number of different

arrangements, such as those shown in Figures 10 to 13. It will be appreciated that more than two airbricks may be stacked together in the above described aligned and/or staggered arrangements, in order to provide the desired levels of ventilation. This provides a flexible arrangement that can be varied in order to suit the desired application, for example to suit a building's ventilation and/or aesthetic requirements.

In order to install the airbricks 21, 22, 34 in a structure of a building, such as a wall 32, a first row of structural bricks 33, e.g. masonry bricks, is laid. As the structural bricks 33 are laid, a first airbrick 21 is included in the row, in place of a structural brick 33. Once the row has been laid, a layer of adhesive 40, in the form of cement, is placed on the first row. The cement 40 is placed on the first surface 6 of the first airbrick 21, between the formations 18. A second row of structural bricks 33 is placed on the first row. As the second row is laid, a second said airbrick 22 is placed on the first airbrick 21 and some or all of the formations 18 on the first surface 6 of first airbrick 21 are engaged with some or all of the cooperating formations 19 on the second surface 7 of the second airbrick 22. The formations 18 and cooperating formations 19 are engaged with each other as described above.

The first and second airbricks 21, 22 can be engaged in lengthwise alignment, by engaging formations 18 and cooperating formations 19 that are located at corresponding lengthwise positions. Alternatively, the first and second airbricks 21, 22 can be staggered in the lengthwise direction by engaging formations 18 and cooperating formations 19 that are located at different lengthwise positions, as described above.

When the formations 18 and cooperating formations 19 are engaged, the respective first and second surfaces 6, 7 of the first and second airbricks 21, 22 are spaced from each other by the combined length of first section 24 of the body of the formation 18 and the body 26 of the co-operating formation 19. The cement laid on the first airbrick is received within this space, as the formation and cooperating
5 formations 18, 19 of the first and second airbricks 21, 22 are engaged.

Additional rows of bricks, with one or more airbricks, may be laid as required.

In conclusion, the present invention provides an airbrick that can be engaged with another said airbrick without causing cement to be knocked off adjacent airbricks or structural bricks in a building. In addition, the engaged airbricks are difficult, if not
10 impossible, to remove from a structure in which they are installed by forcibly sliding them out of the structure.

Furthermore, the airbrick can be engaged with another airbrick, in an adjacent row in a structure of a building, in both an aligned or staggered arrangement as
15 desired. Since the engaged airbricks can be staggered, they do not interfere with the normal staggered arrangement of masonry bricks.

The above embodiment is described by way of example. Many variations are possible without departing from the invention, as defined by the appended claims.

CLAIMS

1. A set of ventilation units comprising first and second ventilation units, wherein a surface of the first ventilation unit is provided with at least one formation and a surface of the second ventilation unit is provided with at least one co-operating formation, wherein said at least one formation and said at least one co-operating formation are engageable with one another in a direction that is substantially perpendicular to said surface of the first ventilation unit and/or to said surface of the second ventilation unit.
2. A set of ventilation units according to claim 1 wherein the at least one formation protrudes outwardly from said surface of the first ventilation unit and the at least one co-operating formation protrudes outwardly from said surface of the second ventilation unit.
3. A set of ventilation units according to any preceding claim wherein the first or second ventilation unit is an air-brick.
4. A set of ventilation units according to any preceding claim wherein each of the first and second ventilation units is an air-brick.
5. A set of ventilation units according to any preceding claim wherein the at least one formation and at least one co-operating formation are disengageable from one another in a direction that is substantially perpendicular to said surface of the first ventilation unit and/or said surface of the second ventilation unit.
6. A set of ventilation units according to any preceding claim wherein the at least one formation and the at least one co-operating formation are arranged such that when they are engaged they are attached to one another.

7. A set of ventilation units according to any preceding claim wherein the at least one formation and at least one co-operating formation are arranged such that when they are engaged, the first and second ventilation units are constrained from relative movement in the length and/or width directions of the ventilation units.
- 5
8. A set of ventilation units according to any preceding claim wherein the at least one formation and the at least one co-operating formation are engageable by a push-fit engagement.
9. A set of ventilation units according to any preceding claim wherein the at least one formation and the at least one co-operating formation are engageable by an interference fit.
- 10
10. A set of ventilation units according to any preceding claim wherein the at least one formation protrudes outwardly from said surface of the first ventilation unit in a direction which is substantially perpendicular to said surface.
- 15
11. A set of ventilation units according to any preceding claim wherein the at least one co-operating formation is arranged to receive said formation in a direction which is substantially perpendicular to said surface of the second ventilation unit.
- 20
12. A set of ventilation units according to any preceding claim wherein the at least one co-operating formation comprises a surface that defines a space for receiving the at least one formation and said space has a longitudinal axis that is substantially perpendicular to said surface of the second ventilation unit.

13. A set of ventilation units according to claim 12 wherein said surface is arranged to form an interference fit with the at least one formation when the at least one formation is received within said space.
14. A set of ventilation units according to claim 12 or 13 wherein the at least one formation and the at least one co-operating formation are engageable by slidably receiving the at least one formation within said space of the at least one co-operating formation.
15. A set of ventilation units according to any of claims 12 to 14 wherein the at least one formation has a longitudinal axis that is substantially perpendicular to said surface of the first ventilation unit and said axis is substantially parallel to the longitudinal axis of said space defined by said surface of the at least one co-operating formation when the at least one formation is received within said space.
16. A set of ventilation units according to any preceding claim wherein the first ventilation unit is stackable on or against the second ventilation unit.
17. A set of ventilation units according to any preceding claim wherein said surfaces of the first and second ventilation units are arranged such that, when the at least one formation and the at least one co-operating formations are engaged, said surfaces are substantially parallel.
18. A set of ventilation units according to any preceding claim wherein the first and second ventilation units are arranged to provide an intervening space between said first and second surfaces when the at least one formation and the at least one co-operating formation are engaged.

19. A set of ventilation units according to claim 18 comprising a spacer element arranged to provide said intervening space.
20. A set of ventilation units according to either of claims 18 or 19 wherein said intervening space is for receiving an adhesive.
- 5 21. A set of ventilation units according to any of claims 18 to 20 when dependent, directly or indirectly, on claim 12 wherein said surface of the at least one cooperating formation comprises a section which is arranged to act in limiting abutment with the at least one formation when the at least one formation and the at least one cooperating formation are engaged and wherein said section is
- 10 distanced from said surface of the second ventilation unit in a direction which is substantially perpendicular to the surface of the second ventilation unit.
22. A set of ventilation units according to any preceding claim wherein the first and second ventilation units are arranged such that, when the at least one formation and the at least one co-operating formation are engaged, respective
- 15 lengthwise ends of the first and second ventilation units are substantially aligned.
23. A set of ventilation units according to claim 22 wherein the at least one formation and the at least one co-operating formation are located substantially the same distance as each other from respective lengthwise ends of the first
- 20 and second ventilation units respectively.
24. A set of ventilation units according to any of claims 1 to 21 wherein the first and second ventilation units are arranged such that, when the at least one

formation and the at least one co-operating formation are engaged, the first and second ventilation units are staggered in the lengthwise direction.

25. A set of ventilation units according to claim 24 wherein the at least one formation and the at least one co-operating formation are provided at different length-wise positions of the first and second ventilation units respectively.
26. A set of ventilation units according to either of claims 24 or 25 wherein the first and second ventilation units are arranged such that when the at least one formation and the at least one co-operating formation are engaged, a lengthwise end of the first ventilation unit is substantially aligned with a perpendicular bisector that passes through the mid-point of the length of the second ventilation unit, or vice versa.
27. A set of ventilation units according to claim 26 wherein the at least one formation is distanced from a lengthwise end of the first ventilation unit by substantially the same amount as the at least one co-operating formation is distanced from a perpendicular bisector that passes through the mid-point of the length of the second ventilation unit.
28. A set of ventilation units according to any preceding claim wherein the at least one cooperating formation comprises first and second said cooperating formations, said first co-operating formation is disposed at a corresponding position along the length of the second ventilation unit as the at least one formation of the first ventilation unit is along the length of the first ventilation unit and said second co-operating formation is spaced from the first co-operating formation in the length direction of the second ventilation unit.

29. A set of ventilation units according to any preceding claim wherein the first and second ventilation units are arranged such that, when the at least one formation and co-operating formation are engaged, width-wise ends of the first and second ventilation units are substantially aligned.
- 5 30. A set of ventilation units according to any preceding claim wherein the at least one formation comprises a plurality of said formations and said formations are provided at different lengthwise positions on said surface of the first ventilation unit, the at least one cooperating formation comprises a plurality of said cooperating formations and said formations are provided at different
10 lengthwise positions on said surface of the second ventilation unit.
31. A set of ventilation units according to claim 30 wherein the formations and cooperating formations that are provided at different lengthwise positions are engageable with one another.
32. A set of ventilation units according to either of claims 30 or 31 wherein the
15 formations and co-operating formations provided at corresponding lengthwise positions are engageable with one another.
33. A set of ventilation units according to any preceding claim wherein the first and second ventilation units are substantially identical.
34. A first ventilation unit comprising a first surface provided with at least one
20 formation and a second surface provided with at least one co-operating formation, wherein said at least one formation is engageable with the at least one co-operating formation of a second said ventilation unit in a direction that

is substantially perpendicular to the first surface of the first ventilation unit and/or to the second surface of the second ventilation unit.

35. A first ventilation unit according to claim 34 wherein the at least one formation protrudes outwardly from said first surface and the at least one co-
5 operating formation protrudes outwardly from said second surface.
36. A first ventilation unit according to claim 34 or 35 wherein the unit is an air-brick.
37. A method of stacking a set of ventilation units according to any of claims 1 to
10 33 comprising: providing said first and second ventilation units, and stacking the first ventilation unit on the second ventilation unit to engage the at least one cooperating formation of the second ventilation unit with the at least one formation of the ventilation unit in a direction that is substantially perpendicular to said surface of the first ventilation unit and/or said surface of the second ventilation unit.
- 15 38. A method of installing a set of ventilation units according to any of claims 1 to 33 in a structure of a building, comprising laying a first row of structural bricks, providing the first ventilation unit in said first row, laying a second row of structural bricks adjacent said first row, providing the second ventilation unit in said second row and engaging the at least one cooperating formation of
20 the second ventilation unit with the at least one formation of the first ventilation unit in a direction that is substantially perpendicular to said surface of the first ventilation unit and/or said surface of the second ventilation unit.

39. A method according to claim 38 of installing a set of ventilation units according to any of claims 24 to 27 wherein the first and second ventilation units are staggered in the lengthwise direction.
40. A method according to claim 38 of installing a set of ventilation units according to claims 22 or 23 wherein the first and second ventilation units are aligned in the lengthwise direction.
41. A method according to any of claims 38 to 40 comprising the step of providing a layer of adhesive material between the first and second ventilation units.

1/9

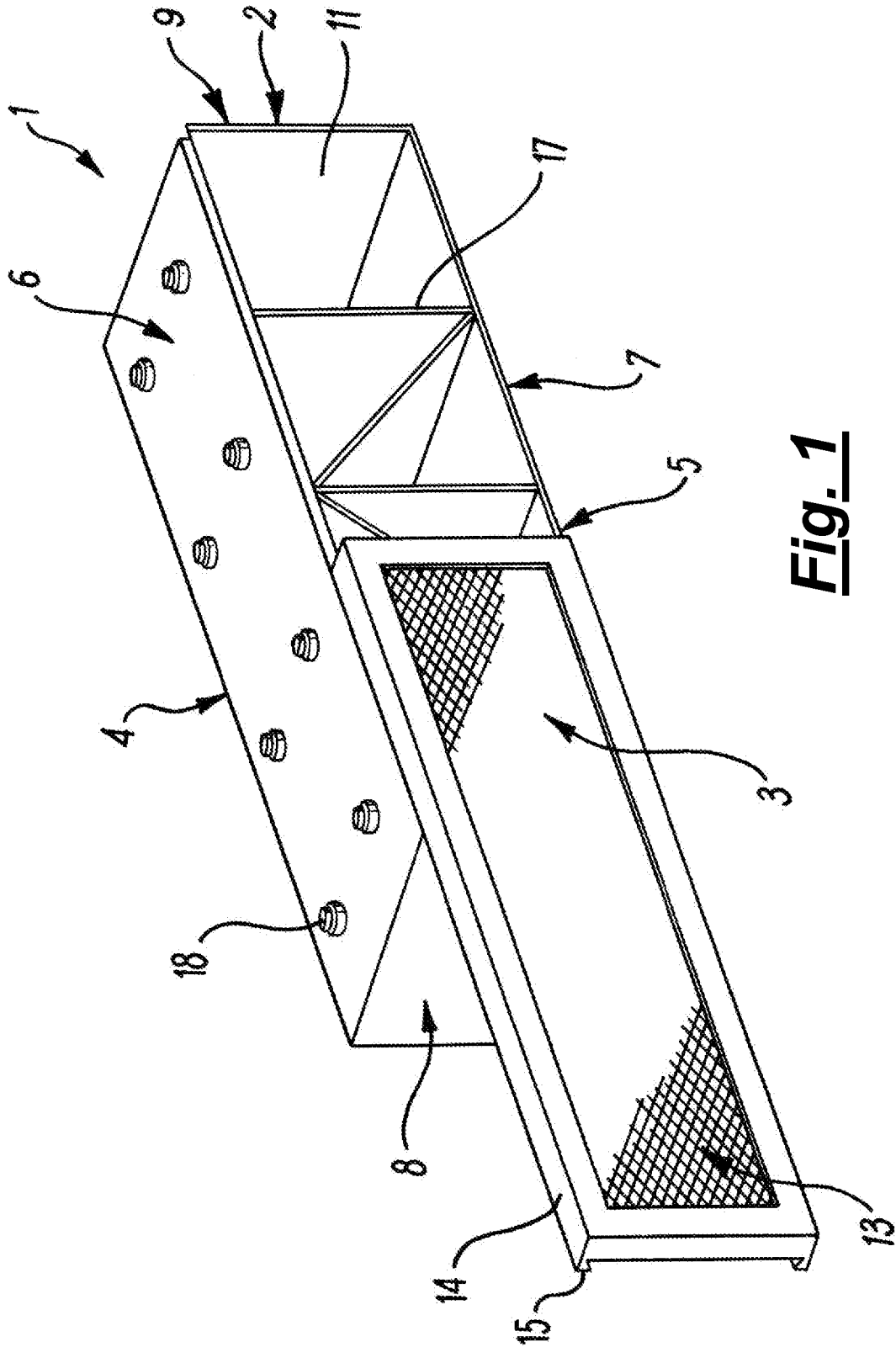
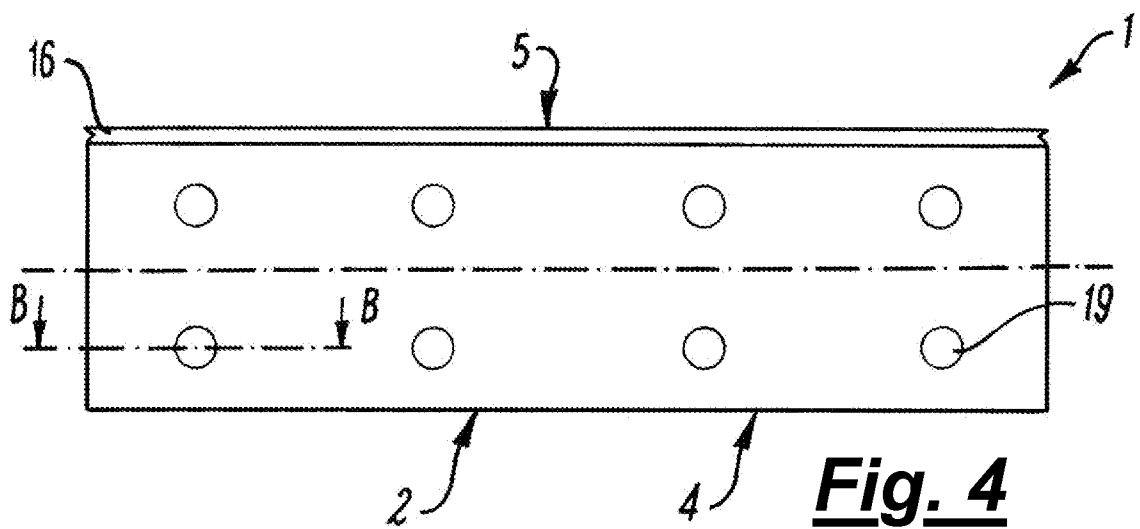
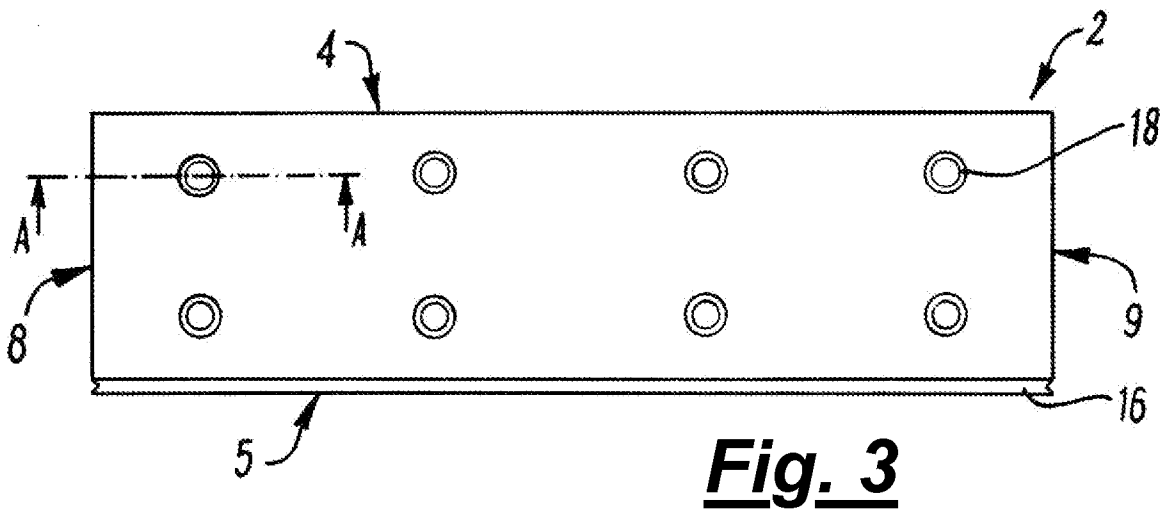
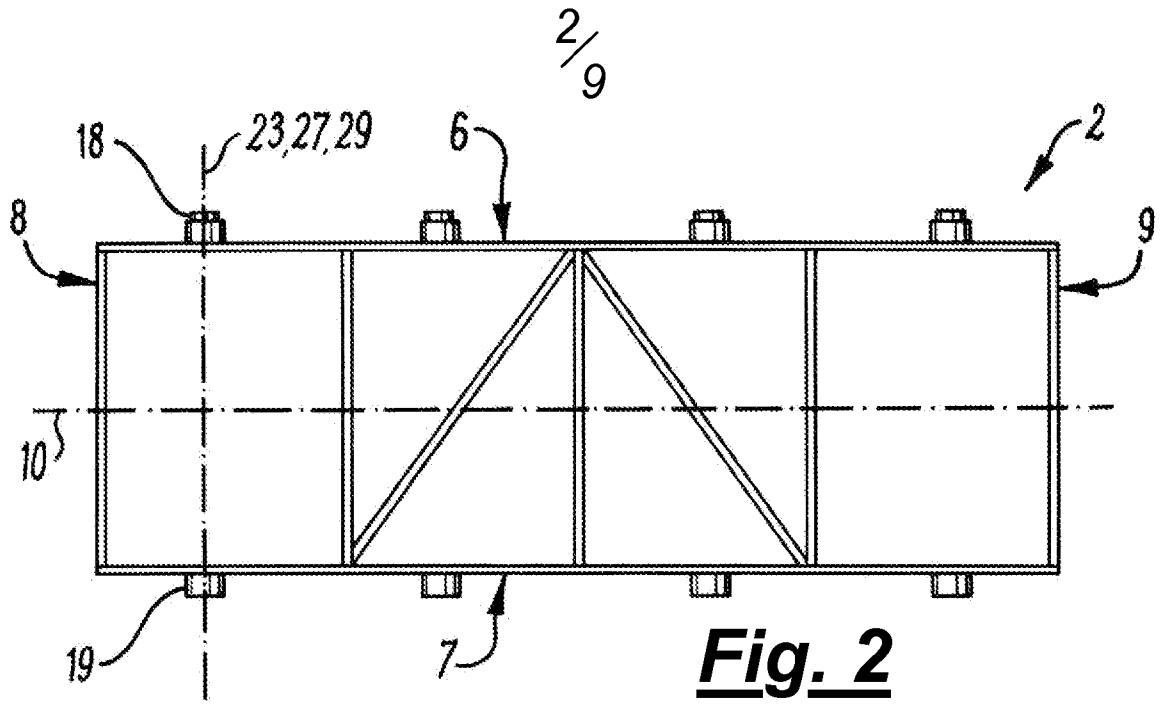

Fig. 1



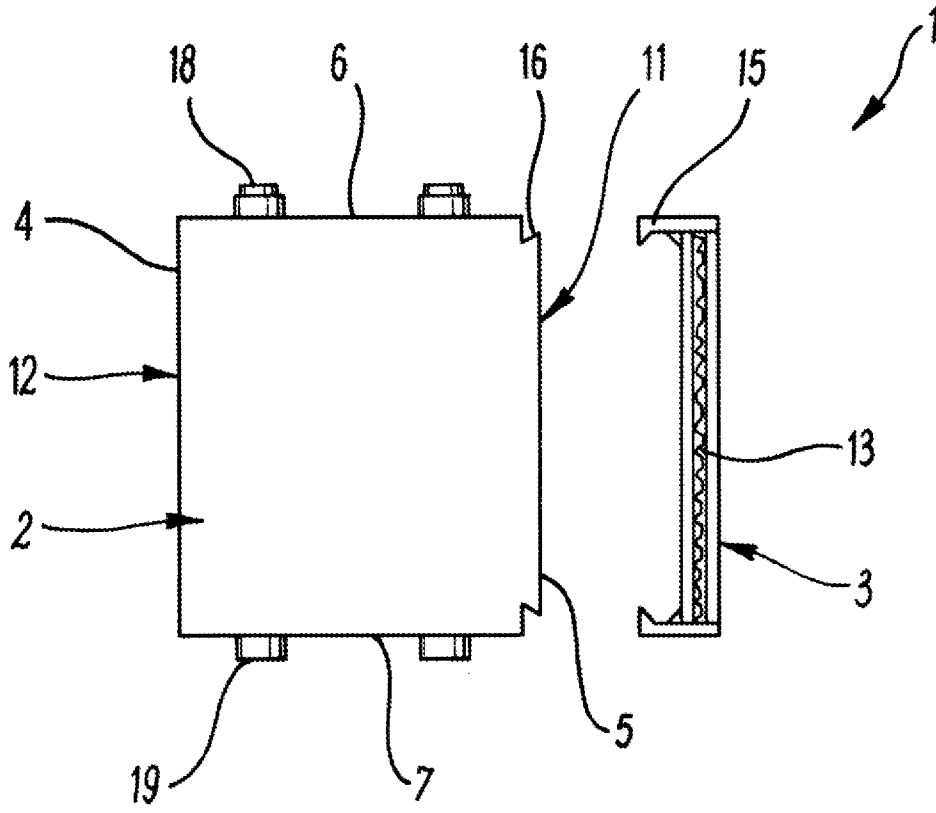

Fig. 5

4/9

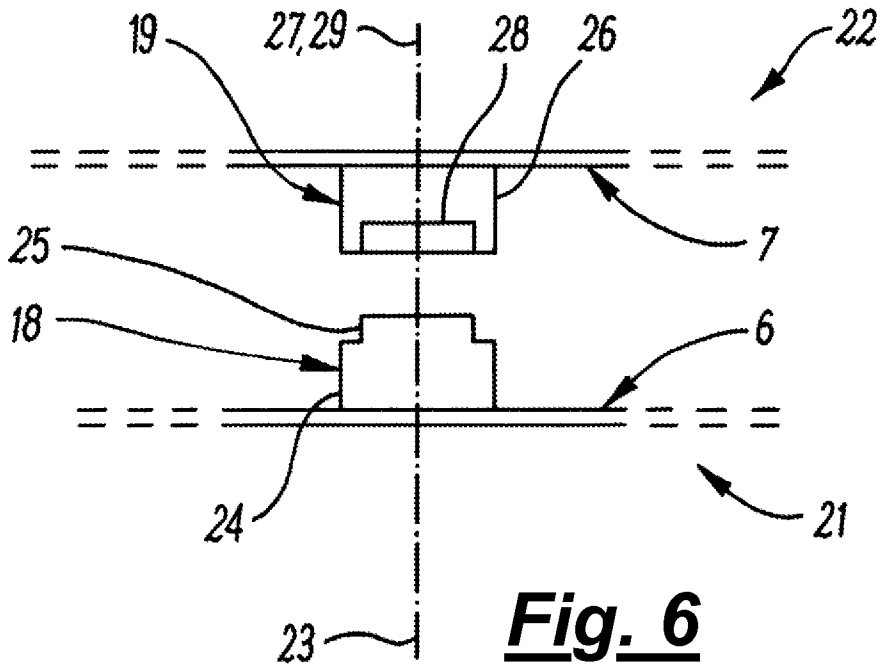

Fig. 6

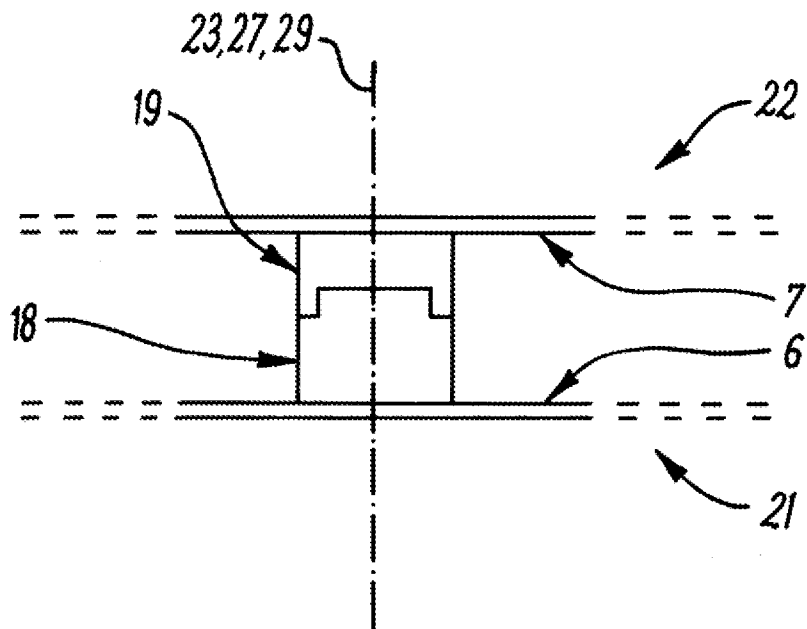

Fig. 7

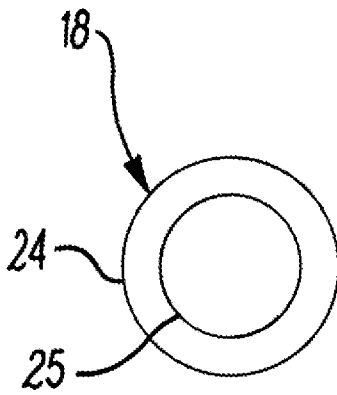

Fig. 8

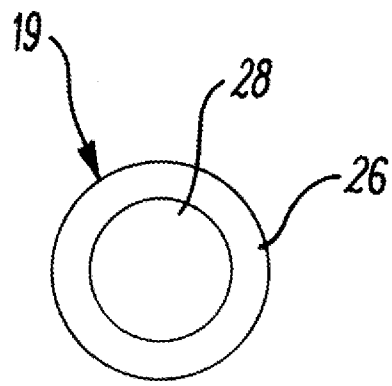

Fig. 9

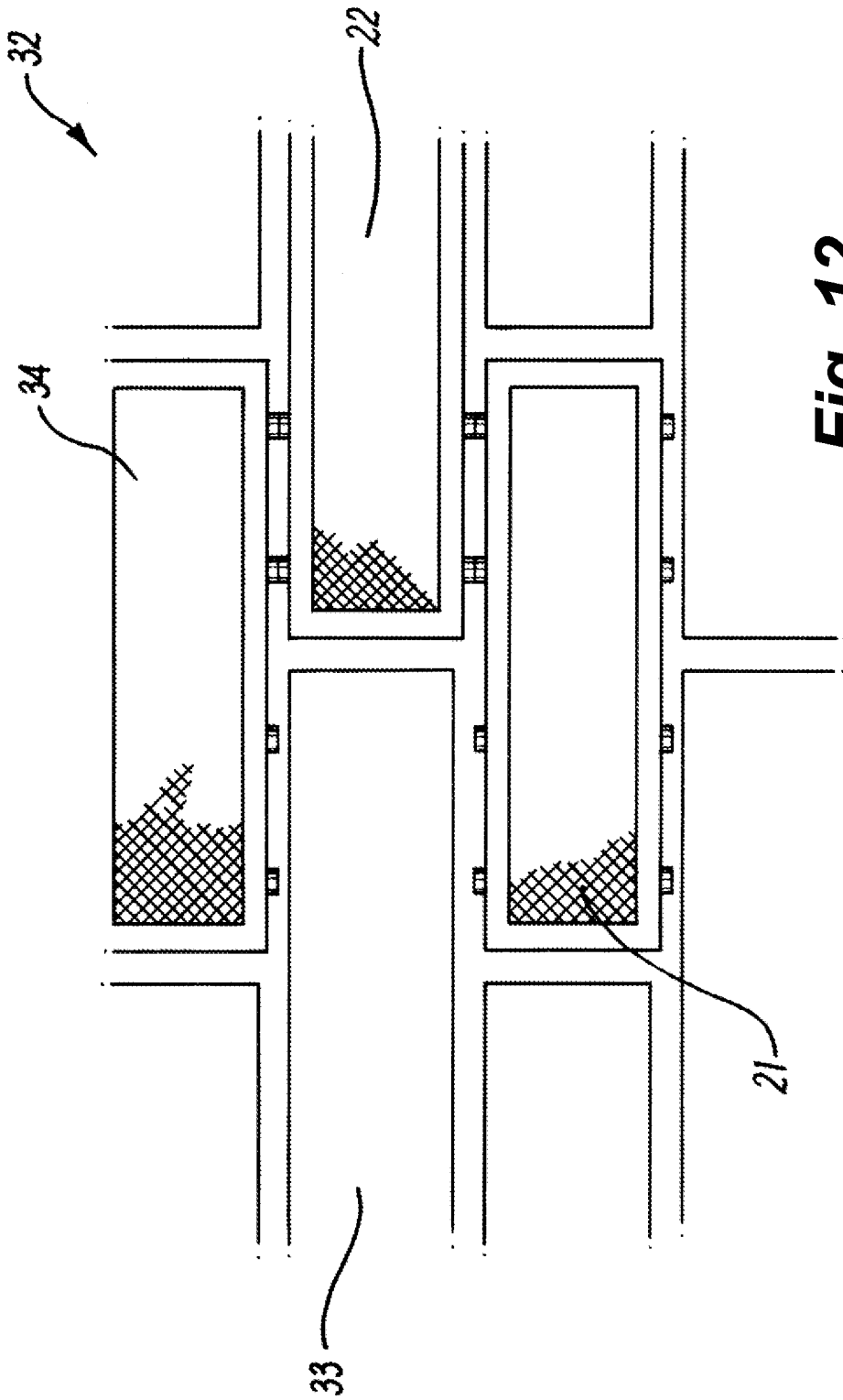

Fig. 12

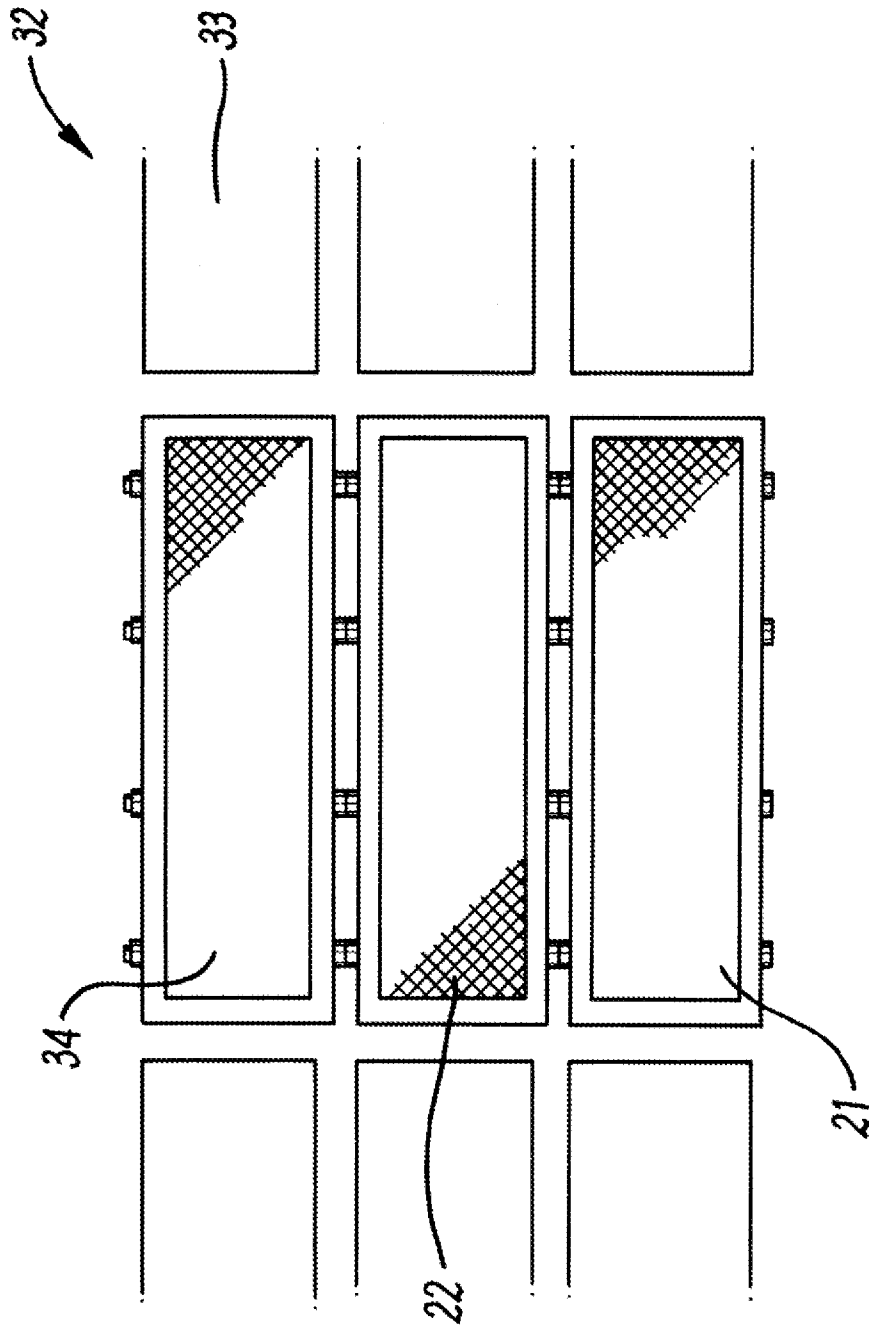

Fig. 13